

(12) INTERNATIONAL APPLICATION PUBLISHED UNDER THE PATENT COOPERATION TREATY (PCT)

(19) World Intellectual Property Organization
International Bureau



(43) International Publication Date
3 July 2003 (03.07.2003)

PCT

(10) International Publication Number
WO 03/053507 A1

(51) International Patent Classification⁷: **A61M 25/10**,
25/00, A61F 2/06

(21) International Application Number: PCT/EP02/14658

(22) International Filing Date:
20 December 2002 (20.12.2002)

(25) Filing Language: English

(26) Publication Language: English

(30) Priority Data:
0130745.3 21 December 2001 (21.12.2001) GB

(71) Applicant and

(72) Inventor: **SHEIBAN, Imad** [IT/IT]; Viale Nino Bixio, 24,
I-37126 Verona (IT).

(72) Inventor; and

(75) Inventor/Applicant (for US only): **VAN DER LEEST,
Machiel** [NL/FR]; 65, rue Halle, F-75014 Paris (FR).

(74) Agent: **BOYDELL, John, Christopher**; Stevens, Hewlett
& Perkins, Halton House, 20/23 Holborn, London EC1N
2JD (GB).

(81) Designated States (national): AE, AG, AL, AM, AT, AU,
AZ, BA, BB, BG, BR, BY, BZ, CA, CH, CN, CO, CR, CU,
CZ, DE, DK, DM, DZ, EC, EE, ES, FI, GB, GD, GE, GH,
GM, HR, HU, ID, IL, IN, IS, JP, KE, KG, KP, KR, KZ, LC,
LK, LR, LS, LT, LU, LV, MA, MD, MG, MK, MN, MW,
MX, MZ, NO, NZ, OM, PH, PL, PT, RO, RU, SD, SE, SG,
SK, SL, TJ, TM, TN, TR, TT, TZ, UA, UG, US, UZ, VC,
VN, YU, ZA, ZM, ZW.

(84) Designated States (regional): ARIPO patent (GH, GM,
KE, LS, MW, MZ, SD, SL, SZ, TZ, UG, ZM, ZW),
Eurasian patent (AM, AZ, BY, KG, KZ, MD, RU, TJ, TM),
European patent (AT, BE, BG, CH, CY, CZ, DE, DK, EE,
ES, FI, FR, GB, GR, IE, IT, LU, MC, NL, PT, SE, SI, SK,
TR), OAPI patent (BF, BJ, CF, CG, CI, CM, GA, GN, GQ,
GW, ML, MR, NE, SN, TD, TG).

Declaration under Rule 4.17:

— of inventorship (Rule 4.17(iv)) for US only

Published:

— with international search report

For two-letter codes and other abbreviations, refer to the "Guidance Notes on Codes and Abbreviations" appearing at the beginning of each regular issue of the PCT Gazette.

(54) Title: BRANCHED BALLOON CATHETER ASSEMBLY

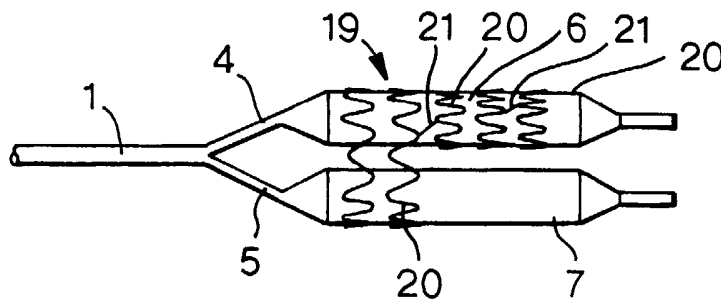

(57) Abstract: A balloon catheter assembly comprising a catheter delivery tube (1) which is branched at its distal end (3) into two branch delivery tubes (4, 5) on each of which are mounted respective inflatable balloons (6, 7). A stent (19) is mounted over the balloons (6, 7) so as to be expanded therewith during deployment. The stent (19) comprises multiple linked cylindrical elements (20) and the arrangement is such that a number of the elements (20) at the proximal end of the stent are of larger diameter than the remainder so as to enable them to receive both balloons (6) and (7), whereas the

elements at the distal end only receive the balloon (6).

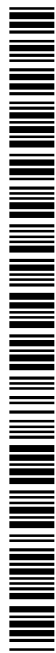

WO 03/053507 A1

BRANCHED BALLOON CATHETER ASSEMBLY

This invention relates to a balloon catheter assembly and to a method of fabricating such an assembly.

5 Balloon catheters are used in the treatment of various anatomical ducts in the body, such as blood vessels, the urinary ducts, or digestive ducts. A particular application is in the treatment of blood vessels exhibiting stenosis.

The conventional balloon catheter comprises a catheter delivery
10 tube on the distal end of which is mounted a balloon of flexible material. During a balloon angioplasty procedure, the balloon is moved along blood vessels within the body to the site of the lesion and, when correctly positioned, is inflated, usually by means of fluid pressure supplied along the hollow interior of the catheter delivery tube. As the balloon inflates it
15 expands against the vessel wall and thus applies outwards pressure to the wall tending to enlarge the vessel's lumen to remove or reduce the effect of a partly blocked vessel. Once the balloon has been inflated to the desired extent, the pressure is released, and the balloon deflates and is removed, leaving the vessel in its enlarged state. In order to avoid collapse of the
20 vessel after treatment, a stent may optionally be carried by the balloon and left in place when the balloon is removed in order to act as a reinforcement for the vessel wall, thus maintaining the enlarged state of the lumen. There are many designs of stent available and their construction and deployment are both well known.

25 The present invention is directed particularly at the treatment of bifurcated vessels, these usually comprising a main branch and a side branch, and wherein treatment is necessary in both branches and/or possibly at the bifurcation itself. Currently treatment of such vessels would usually be carried out with two separate balloon catheters using a
30 technique known as the kissing balloon technique and described, for example, in US Patent No. 4,896,670 and in WO 00/27307. Other techniques, for example using a stent to initially dilate the main branch of

the vessel, may also be used.

The present invention seeks to provide an improved balloon catheter assembly for the treatment of bifurcated vessels, which it is hoped will reduce intervention time and enhance the safety of the surgical procedure.

5 In accordance with a first aspect of the invention there is provided a balloon catheter assembly comprising a catheter delivery tube which is branched at its distal end into at least two branch delivery tubes and wherein each of said branch delivery tubes carries a balloon mounted thereon.

10 Generally speaking each balloon is mounted at the distal end of the respective branch delivery tube.

During a surgical procedure, the two balloons are moved simultaneously to the area to be treated. For this purpose, one or more guide wires may be used, as will be explained in more detail below, and the
15 balloons themselves are generally brought together so as to present the minimum cross sectional area for the journey to the treatment site.

The balloons may each be positioned at the same distance from the branch along their respective branch delivery tubes so that the balloons are essentially in parallel with one another. Typically the distance between the
20 branch and the proximal ends of the balloons will be between 5 mm and 50 mm. Alternatively the balloons may be positioned such that they are positionally stepped in relation to one another.

The balloons may be the same, or different; that is, the physical characteristics of the two balloons such as balloon material, dimensions
25 (diameter, length) and general construction, may be the same as between the two balloons, or they may be different. For example the diameter and length may be different to suit particular circumstances. Alternatively the two balloons may have a different compliance so as to give them different inflation characteristics; this might be desirable where, for example, a layer
30 of plaque on one of the branches of the vessel to be treated has to be broken, this requiring an excess fluid pressure to be applied to the balloon in the branch concerned. If such an increased pressure were also to be

applied to the other balloon, then that balloon might become over-inflated and cause damage to the vessel wall. One way of overcoming this problem is to use independent fluid pressure supplies to the two balloons, as suggested above; however, if the two balloons are supplied from a
5 common supply, an alternative way of dealing with the problem is to make the other balloon of a construction which is less compliant so that, for a given fluid pressure, it inflates to a lesser extent. So-called "non-compliant" balloons are also available which expand, under pressure, up to a given diameter but will not expand significantly further even if the
10 pressure is increased further (subject, of course, to extreme excess pressures being employed).

Variation of compliance can be achieved either by suitable selection of the material of the balloon, or by changing the thickness and other physical characteristics of the balloon, or a combination of both.

15 For operational reasons it is preferred that the distal end of one of the balloons extends beyond that of the other so that, as the catheter assembly is moved towards the treatment site, the distal end of one of the balloons extends beyond that of the other. This can be achieved by appropriate positioning of the balloons on their respective branch delivery
20 tubes, or by appropriate sizing of the balloons, or both. In an embodiment, each of the balloons is formed with a narrow distal end, one of which is longer than the other or others so that the distal tip of the corresponding balloon extends beyond the other or others. This elongated distal end may be rounded at the tip to smooth the passage of the catheter assembly to
25 the treatment site, and to allow positioning of the balloon once there.

At least one of the balloons may be provided with a radio opaque marker positioned at a known position, for example the middle of the balloon, to indicate to the surgeon the start of the bifurcation in the vessel being treated.

30 The catheter delivery tube is hollow to provide for inflation of the balloons from an appropriate fitting at its proximal end. At the point where the catheter delivery tube branches, the hollow interior of the tube may

simply divide into the branch delivery tubes so that the respective balloons may be simultaneously expanded by fluid pressure applied along the catheter delivery tube in the known manner and into the branch delivery tubes. However, it may be necessary to provide for independent inflation
5 of the balloon and, to this end, the hollow interior of the catheter delivery tube may be divided into two or more independent lumens each of which, at the branch, communicates with a respective one of the branch delivery tubes. In this arrangement each balloon may be inflated independently of the other, and not necessarily at the same time.

10 It is well known that a guide wire is generally used to guide a balloon catheter to the treatment site. The balloon catheter assembly of the present invention can also use one or more guide wires for this purpose. Various configurations can be used, for example both balloons over-the-wire or one balloon over-the-wire, the other monorail. The guide wire may
15 extend from a fitting at the proximal end of the catheter delivery tube, or may be introduced at some intermediate position, as is well known. In the latter case, the guide wire may be introduced into the catheter delivery tube at an intermediate position proximal of the branch, or may be introduced into one or both of the branch delivery tubes at some position between the
20 branch and the respective balloon. It is also possible to pre-mount a guide wire within one of the balloons; preferably such a pre-mounted guide wire has a tip which is larger than the guide wire lumen in order to prevent the guide wire from retracting into the lumen. Preferably this tip is rounded or has a higher distal profile and, if fitted on a balloon which extends beyond
25 the other or others, can act as a rounded balloon tip to assist movement of the catheter assembly to the treatment site, as mentioned above.

The pre-mounted guide wire is preferably fixed on the exterior of the catheter delivery tube for packing and transportation purposes, for example by means of silicone O-rings.

30 Once it enters the catheter, whether at the proximal end or at an intermediate position, the guide wire is located in a lumen within the catheter. This lumen may be formed by the passageway through which

pressurised fluid is passed to inflate the balloons, or may be a dedicated lumen.

It will thus be seen that there are various different ways in which the catheter assembly of the invention could use guide wires, and some of these will be described, by way of example, below.

One or both of the balloons may be fitted with a stent which is preferably pre-mounted. Alternatively, a single bifurcated stent may be used, one arm being fitted over each of the balloons. Such bifurcated stents are known in the art.

In accordance with a second aspect of the present invention there is provided a balloon catheter assembly comprising at least two balloons mounted on a stent of the type comprising a plurality of linked cylindrical elements, and wherein at least one of the elements at the proximal end of the stent is adapted to receive and encircle all of said balloons whilst the remaining elements are adapted to receive some, but not all, of said balloons.

The two balloons may be separate balloons, or may be realised by the separate arms of a bifurcated balloon – as is well known a bifurcated balloon may comprise a common part and two or more arms extending therefrom.

The catheter assembly may be of any suitable type comprising multiple balloons, for example the bifurcated type mentioned above. In the preferred embodiment however, the catheter assembly is constructed in accordance with the first aspect of the invention, in which separate balloons are each mounted on a respective branch delivery tube which has itself branched from a common catheter delivery tube.

The stent comprises a plurality of individual, longitudinally aligned, cylindrical elements. Such stents use one or more linking members to link together the adjacent cylindrical elements so that the stent as a whole takes up a generally tubular configuration. A stent of this type is described, for example, in international patent application No. WO98/58600. For the purpose of the present invention, it has been found

that a stent of this type which uses just a single linking member between each pair of adjacent cylindrical elements is particularly suitable, and such a stent is described in GB-A-2369062.

In order to use a multi-element stent of the type mentioned above in
5 the catheter assembly of the present invention, the stent is arranged so that some of the cylindrical elements encircle both balloons whilst the remaining cylindrical elements encircle just one of the balloons. One method of realising this is as follows:-

1) A standard stent is subjected to a pre-crimping operation such as
10 to leave some of the cylindrical elements at the proximal end of a larger diameter than the remainder. This may be achieved either by crimping the cylindrical elements at the proximal end to a lesser extent to those at the distal end, or by leaving the cylindrical elements at the proximal end un-crimped, and crimping only the distal cylindrical elements to make them of
15 smaller diameter.

2) A balloon catheter assembly comprising two balloons is mounted on the pre-crimped stent in such a way that the larger diameter proximal end encloses both balloons, whilst the smaller diameter distal end encloses just one of the balloons.

3) The stent is then subjected to a further crimping operation
20 intended to bring both the distal and proximal parts of the stent down to a size which causes them to securely retain the mounted balloon assembly, taking into account the fact that the bulk of the assembly within the stent at its proximal end is greater than at its distal end. This will be explained in
25 more detail below.

In accordance with a third aspect of the invention, there is provided a method of fabricating the catheter assembly of the type described in the second aspect above, said method comprising:

(a) subjecting the stent to a first crimping operation which results in
30 the diameter of said at least one of the elements being greater than that of said remaining elements;

(b) placing said balloons into the stent in such a way that all of said

balloons occupy said at least one cylindrical element, but a fewer number of said balloons occupy said remaining elements; and

(c) subjecting the stent to a further crimping operation to provide the whole assembly with structural integrity and to reduce its cross sectional
5 size sufficiently to enable it to be deployed.

In order that the invention may be better understood, several embodiments thereof will now be described by way of example only and with reference to the accompanying drawings in which:-

Figures 1 to 3 each illustrate diagrammatically an embodiment of the
10 first aspect of the invention;

Figure 4 illustrates diagrammatically the catheter assembly of Figures 1 to 3 mounted on a stent in accordance with the second aspect of the invention;

Figure 5 is a perspective view of the catheter assembly and stent
15 shown in Figure 4; and

Figure 6 illustrates diagrammatically a typical sequence of steps which may be used to fabricate the stent assembly according to the second aspect of the invention.

Referring firstly to Figure 1 there is shown a balloon catheter
20 assembly constructed in accordance with the invention. The assembly comprises a catheter delivery tube 1 having, at its proximal end, a conventional fitting, represented diagrammatically under reference 2. At the distal end 3 of the delivery tube 1, the tube branches to form two
25 branch delivery tubes 4,5 which may or may not be the same cross sectional shape as the main delivery tube 1. Mounted on each of the branch delivery tubes 4,5 is a respective inflatable balloon 6,7. For the purpose of illustration, the balloons are shown in a part-inflated state. The construction of the balloons, and the manner of their mounting on the
30 of the balloons is capable of being inflated by means of fluid pressure supplied via lumens in the main delivery tube and the respective branch delivery tube using techniques which are well known. The exact

arrangement of these lumens will depend upon the balloon inflation requirements. If the balloons are to be inflated simultaneously, then fluid pressure for this purpose can be supplied by a single lumen formed in the main delivery tube 1, which branches into respective lumens formed in the branch delivery tubes 4,5. If independent balloon inflation is required, separate lumens will have to be provided in the main delivery tube 1, which separate lumens communicate with the individual lumens formed in the branch delivery tubes 4,5.

The main body of each of the balloons, namely the proximal and distal tapered portions and the cylindrical central portion, are substantially identical, although this need not necessarily be the case. However, the narrowed distal ends 8,9 of the balloons are of different length, that for balloon 7 being longer. The reason for this will be explained below.

Two guide wires 10,11 are used to guide the catheter assembly to the treatment site. The technique is well known and will not be described in detail. During the procedure, each of the guide wires is passed up a respective branch of the vessel to be treated. The guide wires pass through their respective balloons and into a lumen in the respective branch delivery tubes 4,5. The guide wire 10 then passes into a lumen in the main delivery tube 1 and emerges at point 12. The guide wire 11 does not pass beyond the branch, and emerges instead from the branch delivery tube 5 at point 13. Other arrangements are possible: for example both guide wires 10 and 11 could extend into the main delivery tube 1 and emerge at the same or different points.

Figure 2 illustrates an alternative embodiment in which the distal tip of the longer narrowed portion 9 of balloon 7 is formed with a rounded ball 14. Other details are the same, except that it will be noted that only a single guide wire, reference 15, is used, this extending through the balloon 6 and a lumen in branch delivery tube 4, to a lumen in main delivery tube 1.

Figure 3 illustrates a similar arrangement in which the balloon 7 is pre-fitted with a guide wire 17 which has an enlarged end 18 to prevent it from retracting back into the lumen. The enlarged end 18 is conveniently

round, as shown, so as to act in the same way as the rounded ball 14 in the embodiment of Figure 2. The pre-fitted guide wire emerges from the branch tube 5 at point 13, in a similar manner to the arrangement shown in Figure 1, however the guide wire 17 is different in that it travels with the catheter assembly as it is moved to the treatment site. The guide wire 16 is the same as guide wire 10, and is used in the conventional way.

Figures 4 and 5 illustrate a catheter assembly of the type illustrated in Figures 1 to 3 which additionally comprises a stent 19. Any suitable type of stent may be fitted; that illustrated is a standard stent comprising a series of longitudinally-arranged expandable cylindrical elements 20 which are linked together by linking members 21. Such stents are known in the art. One particularly suitable stent is described GB-A-2369062 and is characterised, amongst other things, by having just a single linking member 21 between each cylindrical element 20. The existence of just a single linking member 21 between elements 20 makes this stent particularly suitable for use with the balloon assembly of the present invention. In Figure 4, the stent is arranged such that the leftmost two cylindrical elements 20 encircle both balloons 6 and 7, whereas the remaining three cylindrical elements 20 encircle only the balloon 6. This is clarified in the perspective view in Figure 5 which shows the stent in its expanded state and with the balloons partly deflated.

Figure 6 illustrates the steps in a typical sequence of operations to fabricate the catheter assembly illustrated in Figures 4 and 5.

Figure 6A shows the stent in the form in which it comes from the manufacturing process. The drawing is intended to illustrate a 6-element stent of the type described in GB-A-2369062, but other sizes and types are possible.

Figure 6B illustrates the result of the first step in the process, namely a pre-crimping operation by which the three elements 34-36, at the distal end of the stent are crimped to a smaller diameter than the three elements 31-33 at the proximal end. It will be understood that the split need not be 3-3, as illustrated – another example is a 2-3 split in a five element stent, as

illustrated in Figure 4.

Figure 6C illustrates the stent of Figure 6B in vertical section, with a catheter assembly of the type illustrated in Figures 1 to 3 placed therein. Two possible catheter assemblies are illustrated: that on the left has one
5 balloon 37 shorter than the other balloon 38, both balloons being substantially wholly encompassed by the stent; that on the right also has balloon 37 shorter than balloon 38, but illustrates that the balloon 37 may protrude beyond the confines of the stent.

Figure 6D illustrates the result of a further crimping operation, by
10 which the whole stent – proximal and distal elements – is crimped onto the balloons in order to provide structural integrity sufficient to allow the whole assembly to be handled safely, and also enable it to be of sufficiently small section to pass easily to the treatment site. Figure 6D shows left hand and right hand versions which correspond with those of Figure 6C.

15 The manner in which the above-described catheter assemblies is used will be apparent to those skilled in the art. In the embodiment of Figure 1 the procedure commences by insertion of the guide wires 10 and 11. The balloon 7, having a longer narrowed distal portion 9, will navigate first into one or the other of the branches of the bifurcated vessel to be
20 treated. The balloon 6 will navigate into the remaining branch. Once in position, the balloons are preferably inflated simultaneously to thereby dilate the two branches at the same time. This will prevent dissection and/or occlusion of one of the branches. However, it is possible that one balloon may be inflated before the other, or as an overlapping sequence,
25 depending upon the circumstances. The catheter assembly described above allows flexibility in deciding how the balloons are inflated.

In the embodiment of Figure 2, just a single guide wire 15 is inserted and taken up one of the branches of the bifurcated vessel to be treated. This is then used to guide the catheter assembly to the treatment site with
30 the balloon 6 entering the branch in which the guide wire is situated. The rounded tip 14 enables the balloon 7 to navigate by itself into the other branch.

In the embodiment of Figure 3, the single guide wire 16 is inserted and is then used to guide the catheter assembly to the bifurcation in the vessel being treated. At this point the pre-mounted guide wire 17 can be navigated into one of the branches of the vessel and the catheter advanced
5 to guide the balloon 7 into that branch. Finally, the balloon 6 is navigated into the other branch.

All of the above methods can be used where one or both balloons are pre-fitted with stents. In the case where a bifurcated stent is used, it is possible that one of the "branches" of the stent is shorter than the other.
10 This is not an essential feature of a bifurcated stent but will depend upon conditions at the treatment site. Normally such a stent will be used with the longer branch of the stent in the main branch of the vessel being treated, while the shorter branch of the stent enters a side branch.

CLAIMS

1. A balloon catheter assembly comprising a catheter delivery tube which is branched at its distal end into at least two branch delivery tubes
5 and wherein each of said branch delivery tubes carries a balloon mounted thereon.
2. A balloon catheter assembly as claimed in claim 1 wherein each of the balloons have a different compliance so as to give them different inflation characteristics.
- 10 3. A balloon catheter assembly as claimed in either one of claims 1 or 2 wherein the distal end of one of the balloons extends beyond that of the other.
4. A balloon catheter assembly as claimed in claim 3 wherein each of the balloons is formed with a narrow distal end, one of which is longer than
15 the other so that the distal tip of the corresponding balloon extends beyond the other.
5. A balloon catheter as claimed in claim 4 wherein said one of the narrow distal ends is rounded at its distal tip.
6. A balloon catheter assembly as claimed in any one of the preceding
20 claims wherein each balloon is positioned on its respective branch delivery tube the same distance from the branch as the other.
7. A balloon catheter as claimed in any one of the preceding claims wherein the stent delivery tube has a hollow interior which divides into the branch delivery tubes so that the respective balloons may be
25 simultaneously expanded by means of fluid pressure applied along the catheter delivery tube.
8. A balloon catheter assembly as claimed in any one of claims 1 to 6 wherein the interior of the catheter delivery tube is divided into two independent lumens each of which communicates with a respective one of
30 the branch delivery tubes so that the respective balloons can be expanded independently of one another.
9. A balloon catheter assembly as claimed in any one of the preceding

claims further comprising at least one guide wire, located within a lumen or lumens within the delivery tubes, so as to enable the balloons to be guided to a treatment site.

10. A balloon catheter assembly as claimed in claim 9 wherein a
5 separate guide wire is used for each balloon.
11. A balloon catheter assembly as claimed in either one of claims 9 or 10 wherein one of said guide wires is pre-mounted so as to enable it to be carried to the treatment site with its corresponding balloon.
12. A balloon catheter assembly as claimed in claim 11 wherein the
10 distal tip of said pre-mounted guide wire is larger than the corresponding guide wire lumen so as to prevent the guide wire from retracting into the lumen.
13. A balloon catheter assembly as claimed in any one of the preceding claims wherein one or both balloons are fitted with a stent.
- 15 14. A balloon catheter assembly as claimed in claim 13 wherein a single stent is used for both balloons, said stent comprising a series of longitudinally spaced expandable elements, and wherein a predetermined number of the elements at the proximal end of the stent extend over both balloons, and the remaining elements over just one of the balloons.
- 20 15. A balloon catheter assembly as claimed in any one of claims 1 to 12 wherein said balloons are fitted with a bifurcated stent having two arms, each positioned over a respective balloon.
16. A balloon catheter assembly comprising at least two balloons mounted on a stent of the type comprising a plurality of linked cylindrical
25 elements, and wherein at least one of the elements at the proximal end of the stent is adapted to receive and encircle all of said balloons whilst the remaining elements are adapted to receive some, but not all, of said balloons.
17. A balloon catheter assembly as claimed in claim 16 wherein said at
30 least one of the elements has a greater diameter than said remaining elements.
18. A balloon catheter assembly as claimed in claim 17 wherein the

elements are brought to size by a pre-crimping operation in which said at least one of the elements is crimped to a lesser extent than said remaining elements.

19. A balloon catheter assembly as claimed in claim 17 wherein said
5 remaining elements are pre-crimped to render them of smaller diameter than said at least one of said elements.

20. A balloon catheter assembly as claimed in any one of claims 16 to 19 further comprising a catheter delivery tube which is branched at its distal end into at least two branch delivery tubes on each of which is mounted a
10 respective one of said balloons.

21. A balloon catheter assembly as claimed in claim 20 wherein each of the balloons have a different compliance so as to give them different inflation characteristics.

22. A balloon catheter assembly as claimed in either one of claims 20 or
15 21 wherein the distal end of one of the balloons extends beyond that of the other.

23. A balloon catheter as claimed in any one of claims 20 to 22 wherein the stent delivery tube has a hollow interior which divides into the branch delivery tubes so that the respective balloons may be simultaneously
20 expanded by means of fluid pressure applied along the catheter delivery tube.

24. A balloon catheter assembly as claimed in any one of claims 20 to 22 wherein the interior of the catheter delivery tube is divided into two independent lumens each of which communicates with a respective one of
25 the branch delivery tubes so that the respective balloons can be expanded independently of one another.

25. A method of fabricating the catheter assembly as claimed in any one of claims 16 to 24, said method comprising:

(a) subjecting the stent to a first crimping operation which results in
30 the diameter of said at least one of the elements being greater than that of said remaining elements;

(b) placing said balloons into the stent in such a way that all of said

balloons occupy said at least one cylindrical element, but a fewer number of said balloons occupy said remaining elements; and

- (c) subjecting the stent to a further crimping operation to provide the whole assembly with structural integrity and to reduce its cross sectional
- 5 size sufficiently to enable it to be deployed.

Fig.1.

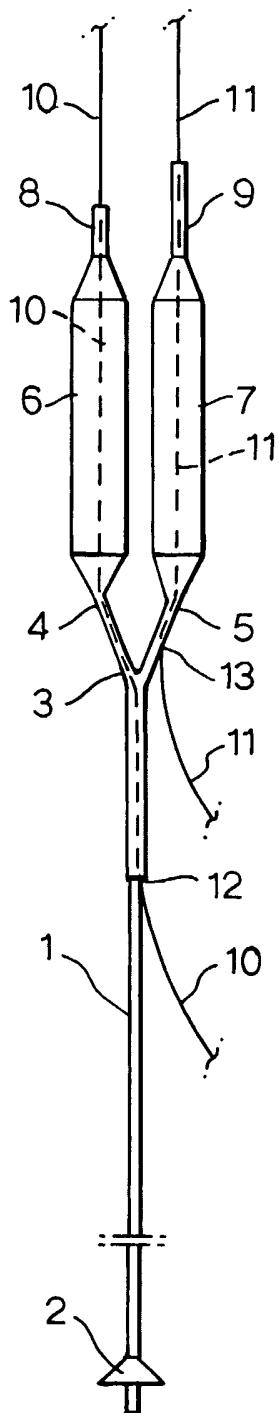

Fig.2.

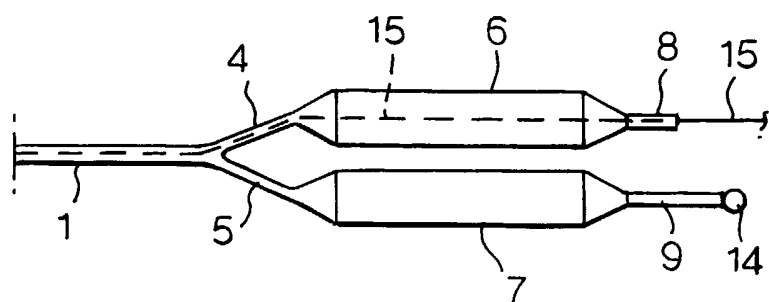

Fig.3.

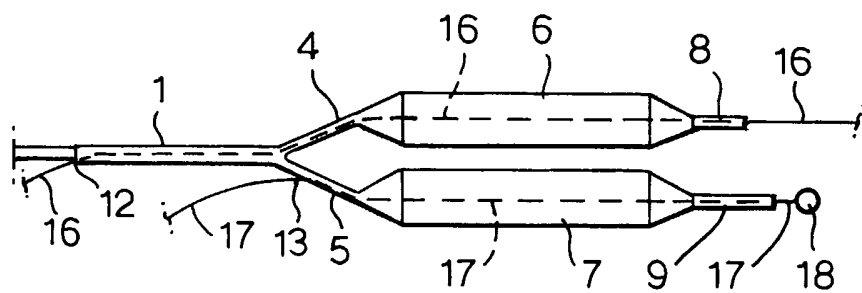

Fig.4.

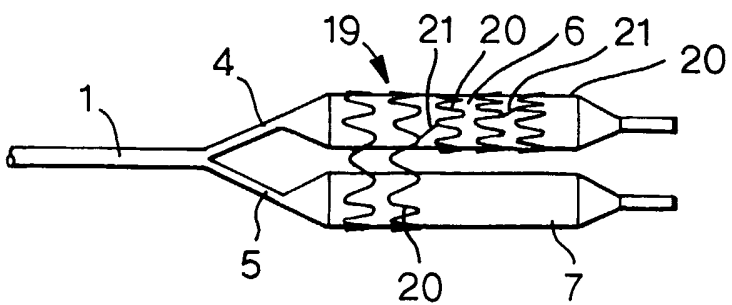

Fig.5.

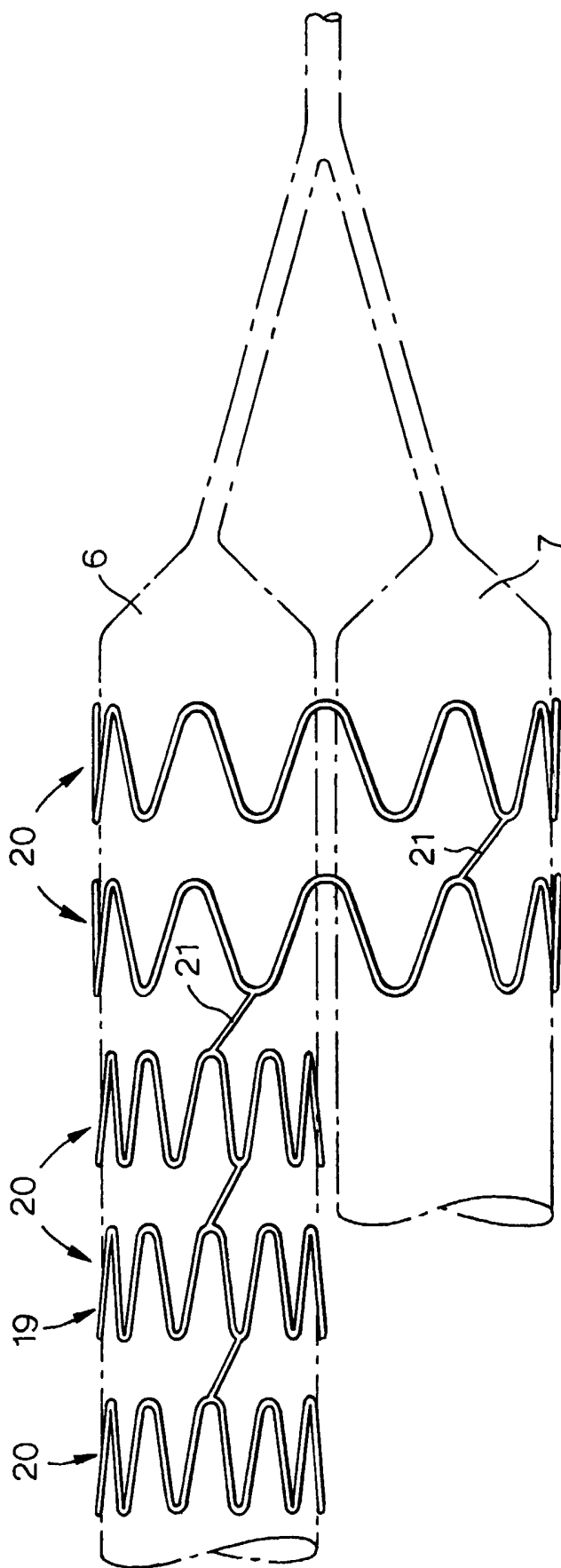

Fig.6A.

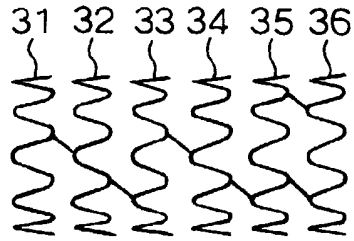

Fig.6B.

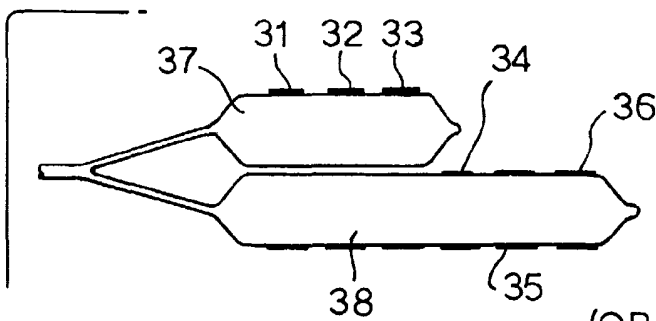
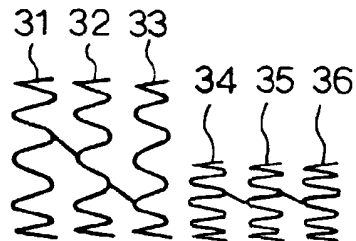

Fig.6C.

(OR)

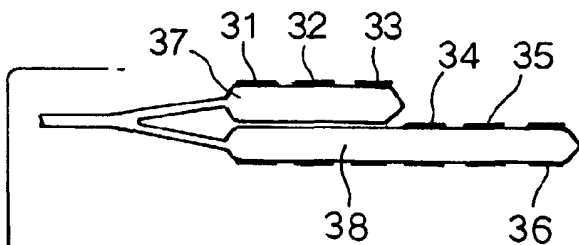
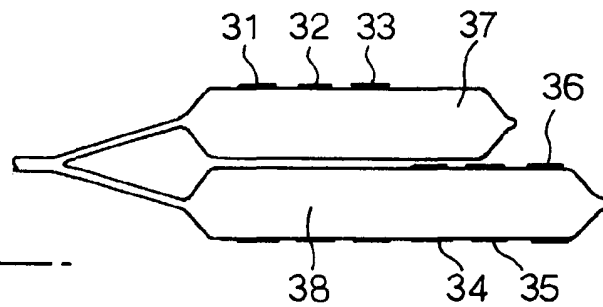
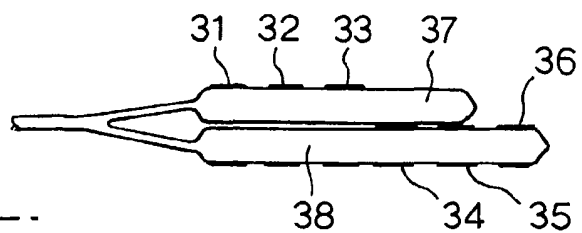

Fig.6D.

(OR)



INTERNATIONAL SEARCH REPORT

International Application No
PCT/EP 02/14658

A. CLASSIFICATION OF SUBJECT MATTER IPC 7 A61M25/10 A61M25/00 A61F2/06				
According to International Patent Classification (IPC) or to both national classification and IPC				
B. FIELDS SEARCHED Minimum documentation searched (classification system followed by classification symbols) IPC 7 A61M A61F				
Documentation searched other than minimum documentation to the extent that such documents are included in the fields searched				
Electronic data base consulted during the international search (name of data base and, where practical, search terms used) EPO-Internal				
C. DOCUMENTS CONSIDERED TO BE RELEVANT				
Category °	Citation of document, with indication, where appropriate, of the relevant passages	Relevant to claim No.		
X	EP 0 965 311 A (MEDTRONIC AVE INC) 22 December 1999 (1999-12-22)	1,3,4, 6-17,19, 22-24		
A	paragraph '0016! - paragraph '0041!; figures 1A,1B,1D,1E,2,2D,3, ---	2,5,18, 20,21,25		
X	WO 99 24104 A (AVE CONNAUGHT) 20 May 1999 (1999-05-20)	1,6,7,9, 10, 13-18, 20,24,25		
A	page 3, line 18 -page 10, line 9; figures 1,4-6 --- -/--	2-5,8, 11,12, 19,21-23		
<input checked="" type="checkbox"/> Further documents are listed in the continuation of box C. <input checked="" type="checkbox"/> Patent family members are listed in annex.				
° Special categories of cited documents :				
<table style="width: 100%; border: none;"> <tr> <td style="width: 50%; border: none; vertical-align: top;"> <ul style="list-style-type: none"> °A* document defining the general state of the art which is not considered to be of particular relevance °E* earlier document but published on or after the international filing date °L* document which may throw doubts on priority claim(s) or which is cited to establish the publication date of another citation or other special reason (as specified) °O* document referring to an oral disclosure, use, exhibition or other means °P* document published prior to the international filing date but later than the priority date claimed </td> <td style="width: 50%; border: none; vertical-align: top;"> <ul style="list-style-type: none"> °T* later document published after the international filing date or priority date and not in conflict with the application but cited to understand the principle or theory underlying the invention °X* document of particular relevance; the claimed invention cannot be considered novel or cannot be considered to involve an inventive step when the document is taken alone °Y* document of particular relevance; the claimed invention cannot be considered to involve an inventive step when the document is combined with one or more other such documents, such combination being obvious to a person skilled in the art. °&* document member of the same patent family </td> </tr> </table>			<ul style="list-style-type: none"> °A* document defining the general state of the art which is not considered to be of particular relevance °E* earlier document but published on or after the international filing date °L* document which may throw doubts on priority claim(s) or which is cited to establish the publication date of another citation or other special reason (as specified) °O* document referring to an oral disclosure, use, exhibition or other means °P* document published prior to the international filing date but later than the priority date claimed 	<ul style="list-style-type: none"> °T* later document published after the international filing date or priority date and not in conflict with the application but cited to understand the principle or theory underlying the invention °X* document of particular relevance; the claimed invention cannot be considered novel or cannot be considered to involve an inventive step when the document is taken alone °Y* document of particular relevance; the claimed invention cannot be considered to involve an inventive step when the document is combined with one or more other such documents, such combination being obvious to a person skilled in the art. °&* document member of the same patent family
<ul style="list-style-type: none"> °A* document defining the general state of the art which is not considered to be of particular relevance °E* earlier document but published on or after the international filing date °L* document which may throw doubts on priority claim(s) or which is cited to establish the publication date of another citation or other special reason (as specified) °O* document referring to an oral disclosure, use, exhibition or other means °P* document published prior to the international filing date but later than the priority date claimed 	<ul style="list-style-type: none"> °T* later document published after the international filing date or priority date and not in conflict with the application but cited to understand the principle or theory underlying the invention °X* document of particular relevance; the claimed invention cannot be considered novel or cannot be considered to involve an inventive step when the document is taken alone °Y* document of particular relevance; the claimed invention cannot be considered to involve an inventive step when the document is combined with one or more other such documents, such combination being obvious to a person skilled in the art. °&* document member of the same patent family 			
Date of the actual completion of the international search	Date of mailing of the international search report			
2 April 2003	14/04/2003			
Name and mailing address of the ISA	Authorized officer			
European Patent Office, P.B. 5818 Patentlaan 2 NL - 2280 HV Rijswijk Tel. (+31-70) 340-2040, Tx. 31 651 epo nl, Fax: (+31-70) 340-3016	Cuiper, R			

INTERNATIONAL SEARCH REPORT

International Application No

PCT/EP 02/14658

C.(Continuation) DOCUMENTS CONSIDERED TO BE RELEVANT		
Category	Citation of document, with indication, where appropriate, of the relevant passages	Relevant to claim No.
X	FR 2 733 689 A (DIBIE ALAIN) 8 November 1996 (1996-11-08)	1,6-11, 13-16, 18-20,24
A	page 1, line 24 -page 12, line 2; figures 10-12	25
X	US 6 099 497 A (ADAMS DANIEL O ET AL) 8 August 2000 (2000-08-08)	1-4,6,8, 10, 13-16, 20,24
A	column 5, line 13 -column 12, line 30; claim 6; figures 6-9,17	25
X	US 5 720 735 A (DORROS GERALD) 24 February 1998 (1998-02-24)	1,5-7, 13,14,16
A	column 4, line 52 -column 7, line 14; figures 10,12	25
X	WO 00 27307 A (VOINOV VALERIAN ;BRAINWAVE CARDIO VASCULAR TECH (IL)) 18 May 2000 (2000-05-18)	1,6,8, 10, 13-16, 20,24
A	claim 6; figures 8,10,17	25

INTERNATIONAL SEARCH REPORT

Information on patent family members

International Application No

PCT/EP 02/14658

Patent document cited in search report	A	Publication date	Patent family member(s)	Publication date
EP 0965311	A	22-12-1999	US 6129738 A EP 0965311 A2	10-10-2000 22-12-1999
WO 9924104	A	20-05-1999	AU 1170199 A EP 0951310 A1 WO 9924104 A1 US 6142973 A	31-05-1999 27-10-1999 20-05-1999 07-11-2000
FR 2733689	A	08-11-1996	FR 2733689 A1	08-11-1996
US 6099497	A	08-08-2000	CA 2321040 A1 EP 1065994 A2 JP 2002505148 T WO 9944539 A2	10-09-1999 10-01-2001 19-02-2002 10-09-1999
US 5720735	A	24-02-1998	NONE	
WO 0027307	A	18-05-2000	WO 0027307 A1 AU 1050899 A	18-05-2000 29-05-2000