

(19)  
(12)

(KR)  
(B1)

(51) 。 Int. Cl. <sup>7</sup>  
G02F 1/133

(45)  
(11)  
(24)

2001 09 22  
10 - 0299535  
2001 06 09

(21) 10 - 1999 - 0019522  
(22) 1999 05 28

(65) 2000 - 0075119  
(43) 2000 12 15

(73) 48 - 3 1/1

20

(72) 5 101 - 910

626 108 303

(74)  
:

(54) -

가 , 가

4

1 X-

2 1 .  
 3 1 .  
 4 1 X- .  
 5 2 X- .  
 6 3 X- .

<

2 : 3 :  
 4 : 5,17 :  
 6 : 7 :  
 8 : 9 :  
 11 : 12 :  
 13 : 14 :  
 15 : 16 :  
 18,21 : 19 :  
 20 : 22,32,42 :  
 23a,23b : 30 :  
 100<sub>1</sub> 100<sub>n</sub>:

- ( 'X- ' ) , X-

가 X- X- 가  
 X- X-

, X- (Active Matrix Liquid Crystal Display :  
 'AMLCD' ) 가 . AMLCD (Thin Film T  
 ransistor : 'TFT' )

1 , X- (6) , (2) (6) X-  
 TFT (4) AMLCD가 . (6) μm (S  
 elenium) TFT (4) X- (6)  
 (7) (8) . (8) (9) . TFT (4) (  
 3) (Cst) TFT (Cst) (GND) (  
 ) .  
 (6)

(6) X- , (6) . (6) X-  
 - (9) . kV (8)  
 (6) 가 - . (5)  
 (Cst) . (3) TFT 가  
 (Cst)

2 3 1 TFT .

2 3 , TFT (4) (11), (15), (14), (12)  
 (13) TFT , / (5,17) (Cst) TFT  
 (Cst) (Passivation) (16) . TFT  
 (3) (19) (3) (Cst) (18)  
 (16) (5) (11) (3) (13)  
 (19) , (13) (12) (5) (C) st)  
 (18) . (17) (Cst) (Ground electrode) ,

X- AMLCD TFT (4) (6) , X-  
 (Cst) 가 . , TFT (4)  
 TFT (4) 가가 . (6)

, TFT X-

가 , X- ,  
 ,  
 X- 가

X -

X -

X -

X -

4 6

4 (Pix) (Pix) (GND)  
 (22) (Cst) (Vtest) (Pix) (Pix)  
 (Cst) / TFT (19) (Amp)  
 X - 가 (Pix)  
 (Pix) 1 (23a) (Pix) 2 (23b)  
 (22) (Pix) (Vtest) 가  
 (Pix) 1 2 (23a,23b) (22) 2 3  
 (5) (Indium Tin Oxide : 'ITO' )  
 가 (16) (5) ( )  
 Cst (Pix) (21) (Vtest) TFT  
 (3) - / (Turn - on/off) (Cst)  
 , TFT (Pix) (19)  
 (Cst)  
 (Cst) (Vtest)

4 (Pix) (Vtest) (22)  
 (Pix) (Cst) (Vtest)  
 (20) (3) , TFT  
 (Pix) (19) (Cst)  
 (Cst) (19) (Amp)

(Vtest) , TFT  
 (6) 가 가

TFT 가 , 1 2 (23a,23b)  
 (22) (6)

5 , (Pix) (30) (Vtest) 가 , I  
 2 X- 가 (30) , I  
 TO (30) (30) (16)  
 , (30) (Cst) ITO  
 , (30) (Cst) TFT ITO  
 가 - / (Turn - on/off) (Vtest) . TFT (3) (30)  
 (32) (Cst) /

(Vtest) (32) (30) ITO (30)  
 (Cst) (Cst)가 (Vtest) (30)  
 TFT (19) (19) (Amp) (Cst)

5 X- TFT 가

6 , n 1 n (100<sub>1</sub> 100<sub>n</sub>) , 1 n 가  
 (100<sub>1</sub> 100<sub>n</sub>) (Vtest) 가 3 X- (23a,  
 23b) . 1 n (100<sub>1</sub> 100<sub>n</sub>) 4 (Pix) 1 2  
 5 (42)  
 1 n (100<sub>1</sub> 100<sub>n</sub>) 가  
 (Vtest) TFT

6 X- (Vtest) 가  
 가 X- X-

가 , X- TFT  
 TFT , TFT , X- TFT  
 (cost)가 ,  
 가, TFT X-  
 TFT

TFT TFT 가 . ,

가

(57)

1.

, /  
- , ,  
가 ,

2.

, /  
- , ,  
가

3.

, /  
- , ,

4.

3 ,

- .

5.

3 ,

-

6.

- ,

/

가

,  
,  
-

7.

6 ,

,

,

가

-

8.

6 ,

-

9.

- ,

/

,

가

10.

, /

11.

10 ,

가

12.

10 ,

13.

10 ,

1

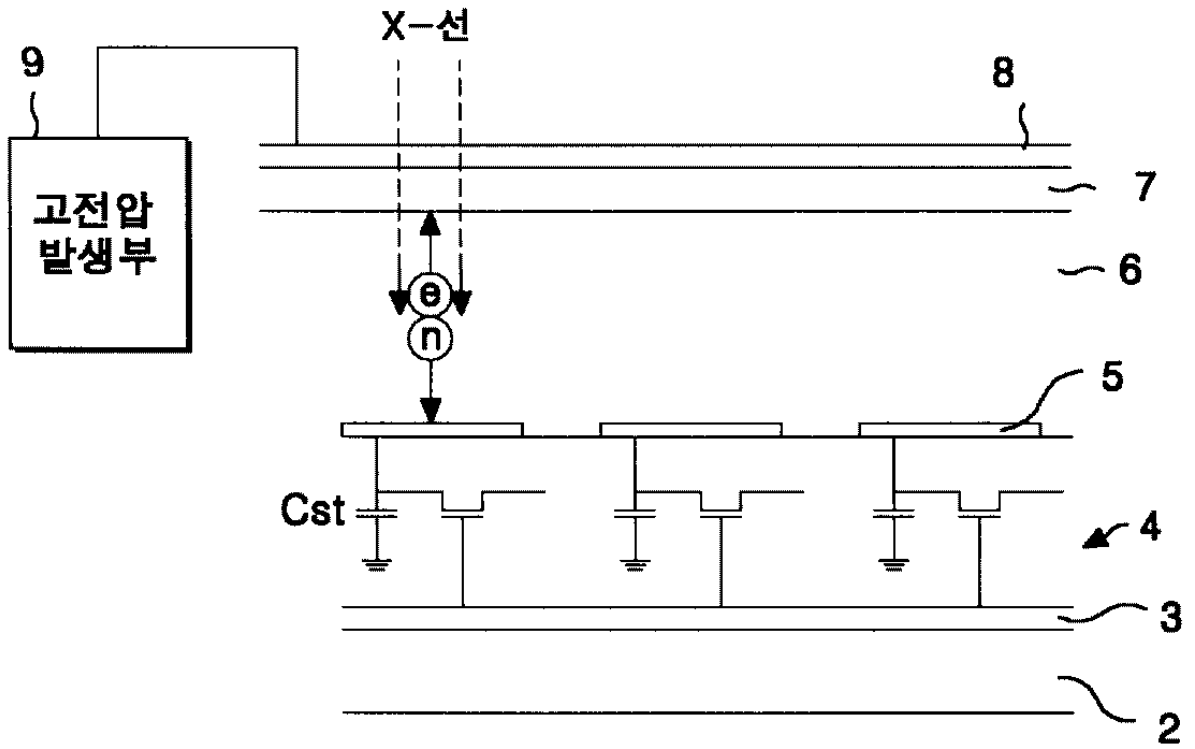



3

