

A. E. KALTSCHMIDT.
 SWITCH OPERATING MECHANISM.
 APPLICATION FILED FEB. 4, 1910.

998,525.

Patented July 18, 1911.

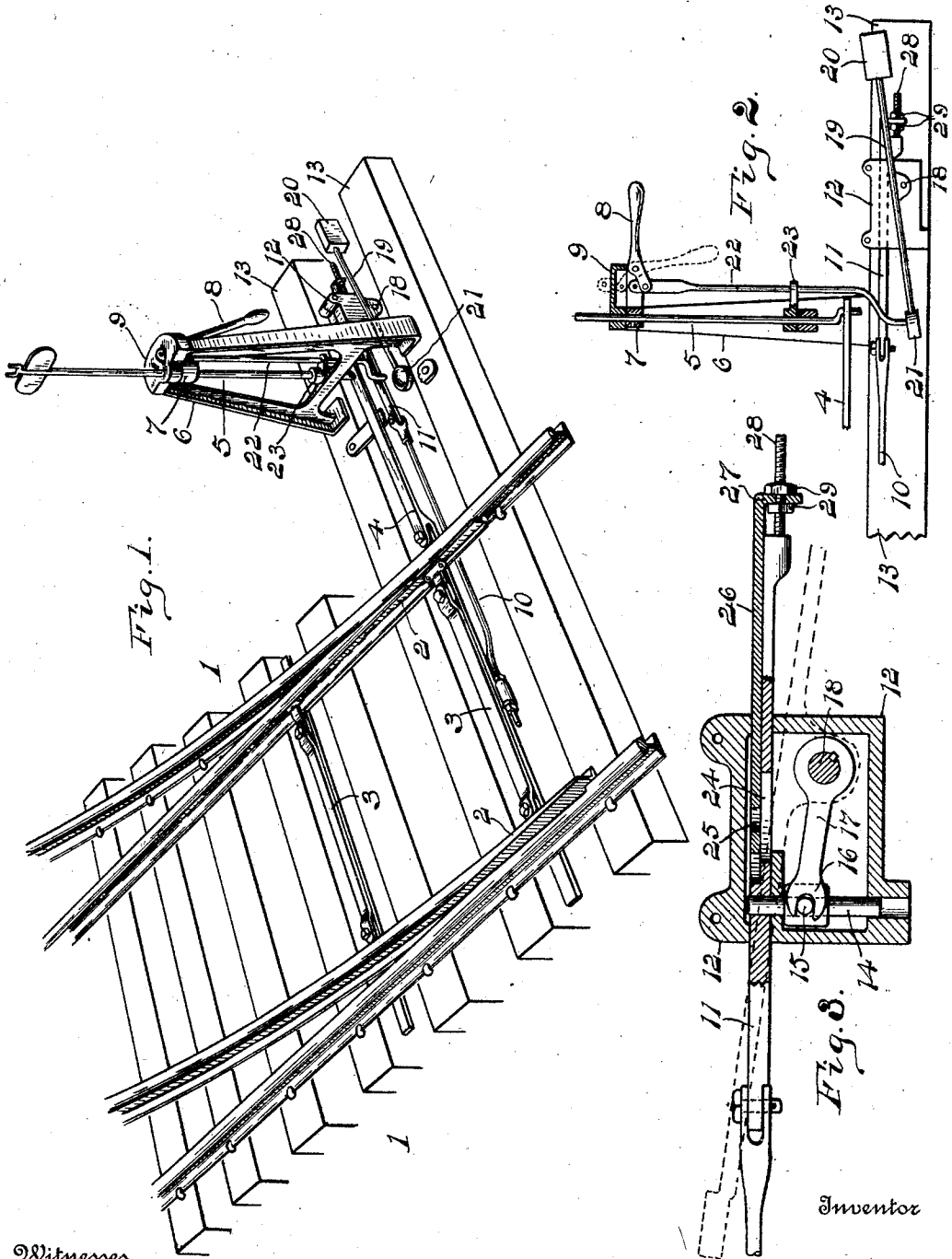

Witnesses
 A. M. Shannon.
 A. M. Dow.

Inventor
 Albert E. Kaltschmidt
 by *Charles H. ...* Attorney

UNITED STATES PATENT OFFICE.

ALBERT E. KALTSCHMIDT, OF DETROIT, MICHIGAN.

SWITCH-OPERATING MECHANISM.

998,525.

Specification of Letters Patent. Patented July 18, 1911.

Application filed February 4, 1910. Serial No. 542,077.

To all whom it may concern:

Be it known that I, ALBERT E. KALTSCHMIDT, a subject of the Emperor of Germany, residing at Detroit, in the county of Wayne and State of Michigan, have invented certain new and useful Improvements in Switch-Operating Mechanism, of which the following is a specification, reference being had therein to the accompanying drawings.

10 In the customary construction of railway switches and switch stands no provision is made for holding the switch points in position in case the switch stand is knocked out of position.

15 This invention relates to a switch that is adapted to automatically lock and hold the switch point in position in case of accident to the switch stand itself.

20 The invention consists in the matters hereinafter set forth, and more particularly pointed out in the appended claims.

25 In the drawings, Figure 1 is a view in perspective of a railway switch and switch stand that embodies features of the invention; Fig. 2 is a view in vertical section through the stand with the parts in released position; and Fig. 3 is a view partly in section and partly in elevation of one form of locking device.

30 Referring to the drawings 1 indicates a portion of a track of standard construction with a pair of switch points 2 coupled by the usual tie bars 3, the forward one of which is connected by a link 4 to an upright crank rod 5. The latter is mounted in any preferred form of switch stand 6 so as to be thrown by a handle 7 whose outer end 8 is pivoted to fall into interlocking relation with a quadrant plate 9 on the stand. A push rod 10 is connected at one end to the tie bar 3 and at the other end to a latch bar 11. The latter is longitudinally reciprocable in a casing 12 that is pivoted or otherwise made fast to one of the track ties 13 on which the stand 6 is placed.

35 A vertical movable pin 14 in the casing 12 is supported by a cross pivot 15 in the forked end 16 of a rock arm 17. The latter is keyed or otherwise secured to a rock shaft 18 journaled in the casing on the outer end of which a lever 19 is secured. A counter-balance weight 20 is secured to the outer end of the lever 19 and a hollow or cupped bearing plate 21 to the other end beneath the switch stand 6. The inner end of the handle member 8 is pivoted to the upper

end of a trigger rod 22 that has sliding engagement in a suitable guide plate 23 on the stand with its foot against the bearing plate 21. The upper end of the pin 14 is adapted to enter suitable apertures in the latch bar 11 when the switch is at either end of its throw. To accommodate switches of different throws one opening 24 of the latch bar is elongated and in register always with a smaller opening 25 formed in a strap 26 whose downturned end 27 is adjustable longitudinally on a screwthreaded stem 28 extending from the adjacent end of the latch bar 11, nuts 29 holding the strap in the desired position.

40 The parts are so proportioned that when the switch handle is raised and therefore unlocked from the quadrant plate of the stand, the weighted lever is depressed, thus moving the latch pin out of engagement with the latch bar and allowing the switch pin to be moved freely. When the switch is thrown as desired, and the handle depressed so as to interlock with the switch quadrant, the weighted lever is free to move down and throw the latch pin into engagement with the latch bar. This holds the switch points fast, and if the stand be overturned they are still kept rigidly in position.

45 Obviously, changes in details of construction may be made without departing from the spirit of the invention and I do not care to limit myself to any particular form or arrangement of parts.

What I claim as my invention is:

1. In a railway switch, the combination with switch points, a switch stand, a crank rod on the stand operatively connected to the points, and a handle for turning the crank rod adapted to interlock with the stand when the points are thrown, of a rod connected to the points, a locking member for said rod, an oscillatory member turned in one direction by gravity to operate the locking member and lock the rod, said oscillatory member having an end extending beneath the switch stand, and a vertically movable member carried by the handle with its lower end maintained in the path of movement of the end of the oscillatory member beneath the stand and its upper end adapted to interlock with the stand when the handle is moved to inoperative position, said movement of the handle also raising said member out of engagement with said

end of the oscillatory member to permit said member to be operated by gravity to lock the said rod.

2. In a railway switch, the combination
5 with switch points, a switch stand, and a
crank rod on the stand operatively con-
nected to the points, of a handle on the
stand rotatable upon a vertical axis to turn
10 the crank rod and pivoted to turn upon a
horizontal axis into inoperative position, a
push rod connected to the points, a lever
adapted to lock the rod having an end
15 extending beneath the stand below the
lower end of the crank rod, and a verti-
cally movable rod extending parallel with
the vertical axis of the crank rod con-
nected to said handle and movable con-
centrically about said axis with said handle
20 and having a lower end offset into aline-
ment with said axis of the crank rod beneath
the lower end of the same and above the end
of said lever for locking the push rod, said
vertically movable rod being moved verti-
cally by the turning of the handle upon its
25 horizontal pivot.

3. In a railway switch, the combination
with switch points, a switch stand, and a
crank rod on the stand operatively con-
nected to the points, of a handle on the
30 stand rotatable upon a vertical axis to turn
the crank rod and pivoted to turn upon a
horizontal axis into inoperative position, a
push rod connected to the points, a locking
member for the push rod, a lever for actu-
35 ating the locking member pivoted inter-
mediate its ends and provided with a weight
at one end and a cup at its opposite end be-
neath the lower end of the crank rod, and a
rod connected to said handle at its upper
40 end to be moved vertically by the turning
of said handle upon its horizontal pivot
and movable with said handle about the
vertical axis of said crank rod, said rod be-
ing provided with a lower end to engage the
45 said cup offset into alinement with said
axis beneath the lower end of said crank
rod.

4. In a railway switch, the combination
with switch points, a switch stand, a crank
50 rod on the stand operatively connected to

the points, and a handle for turning the
crank rod adapted to interlock with the
stand when the points are thrown, of a rod
connected to the points, a casing supported
55 adjacent to the base of the stand, a latch bar
reciprocable through said casing and con-
nected to said push rod, a rock-shaft in the
casing, means in the casing operated by the
turning of the rock-shaft for engaging and
60 locking the latch bar, a lever secured inter-
mediate its ends to the outer end of said
rock-shaft, a weight on one end of said lever
and a cup upon the opposite end beneath the
stand, and a rod pivotally connected to the
65 handle at its upper end to be moved verti-
cally thereby with its lower end above the
said cup.

5. In a railway switch, the combination
with switch points, a switch stand, a crank
rod on the stand operatively connected to
70 the points, and a handle for turning the
crank rod adapted to interlock with the
stand when the pivots are thrown, of a rod
connected to the points, a casing supported
adjacent to the base of the stand, a latch bar
75 reciprocable through said casing and con-
nected to said push rod, a rock-shaft in the
casing, a longitudinally movable pin guided
in the casing and adapted to engage open-
ings in the bar, an arm on the rock-shaft
80 operatively engaging the pin to move the
same, a weighted lever secured to the outer
end of the rock-shaft having an end extend-
ing beneath the lower end of the crank rod,
and an actuating rod for the lever on the
85 stand extending parallel with the crank rod
and carried thereby about the vertical axis
thereof upon the turning of said crank rod
by said handle, said adjusting rod being
connected to said handle at its upper end
90 to be moved vertically thereby and off-set at
its lower end into the vertical axial line of
the crank rod beneath the lower end of the
same to engage the end of the weighted lever.

In testimony whereof I affix my signature 95
in presence of two witnesses.

ALBERT E. KALTSCHMIDT.

Witnesses:

ANNA M. DORR,
G. E. McGRANN.