

(No Model.)

3 Sheets—Sheet 1.

J. & C. DIETZ.
WINDOW ATTACHMENT.

No. 525,006.

Patented Aug. 28, 1894.

Fig. 1.

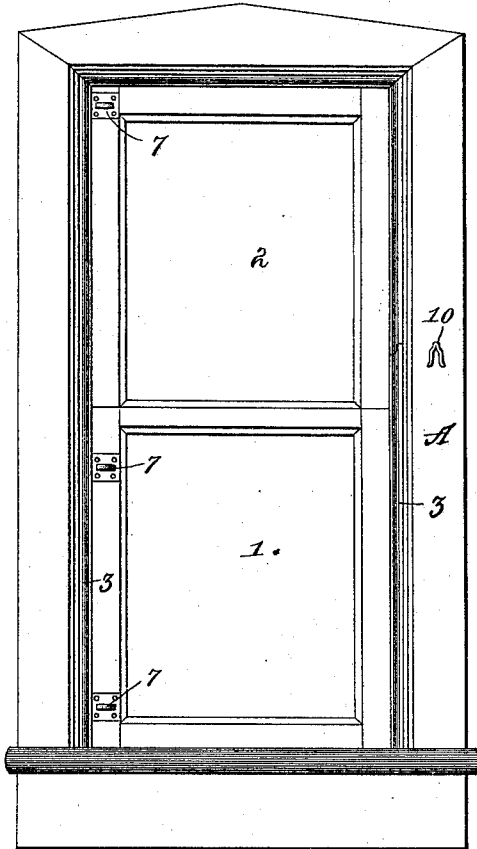

Fig. 2.

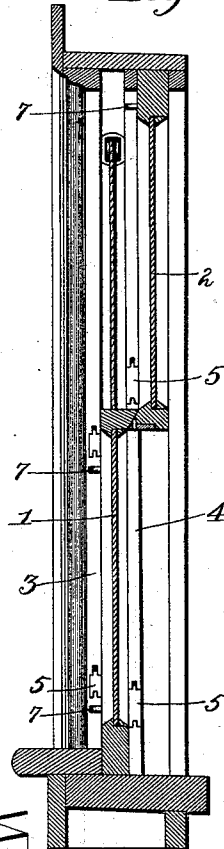

Fig. 10.

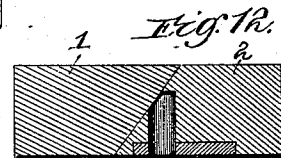
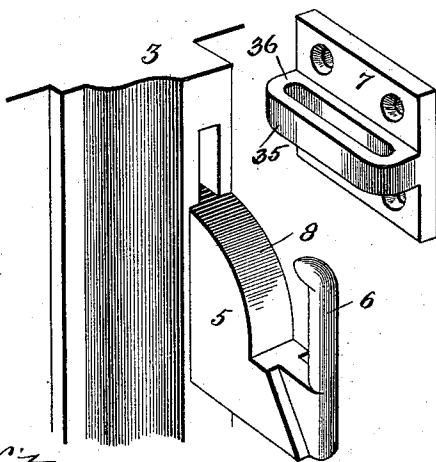
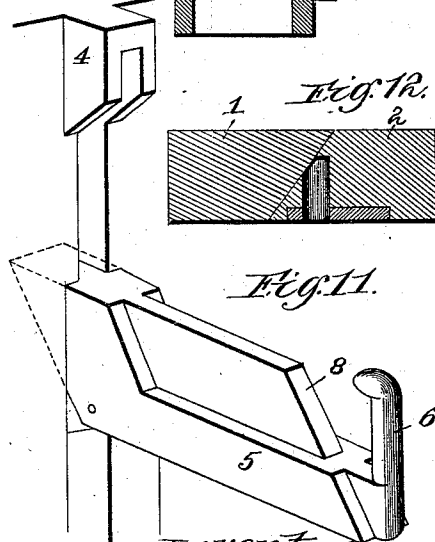

Fig. 11.



Witnesses
 Wm. M. Rheims
 Wm. H. Flaming

Inventors
 Chas. Dietz & John Dietz
 By Raymond & Gubmund

(No Model.)

3 Sheets—Sheet 2.

J. & C. DIETZ.
WINDOW ATTACHMENT.

No. 525,006.

Patented Aug. 28, 1894.

Fig. 5.

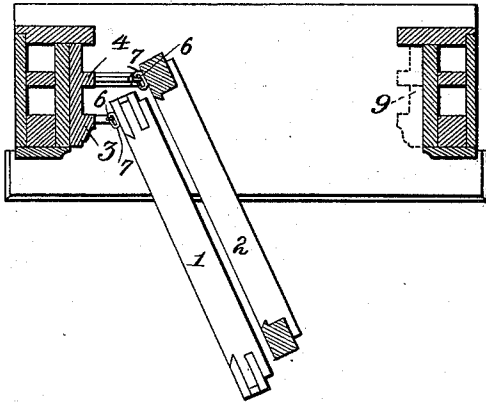

Fig. 4.

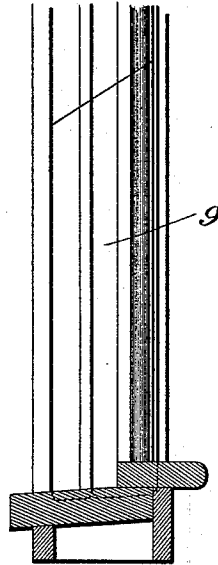

Fig. 7.

Fig. 8.

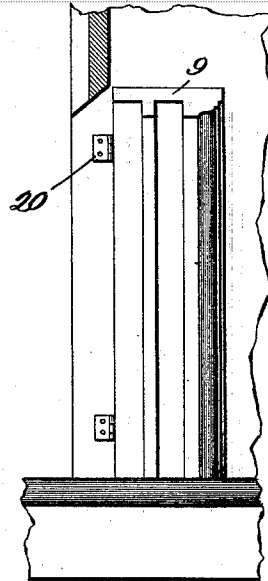
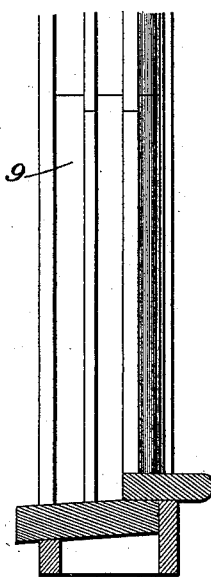
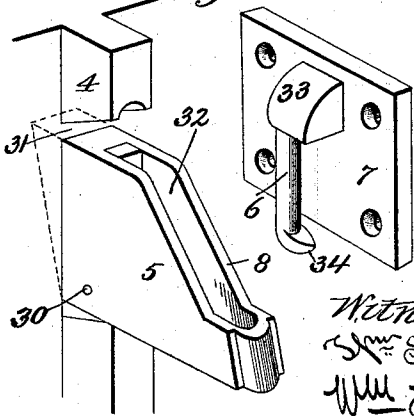

Fig. 9.



Witnesses.
 Wm. M. Phoenix
 Wm. F. Fleming
 Inventors
 Chas. Dietz & Co.
 By John Dietz
 Raymond & Quohndorff
 Attys

(No Model.)

3 Sheets—Sheet 3.

J. & C. DIETZ.
WINDOW ATTACHMENT.

No. 525,006.

Patented Aug. 28, 1894.

Fig. 5.

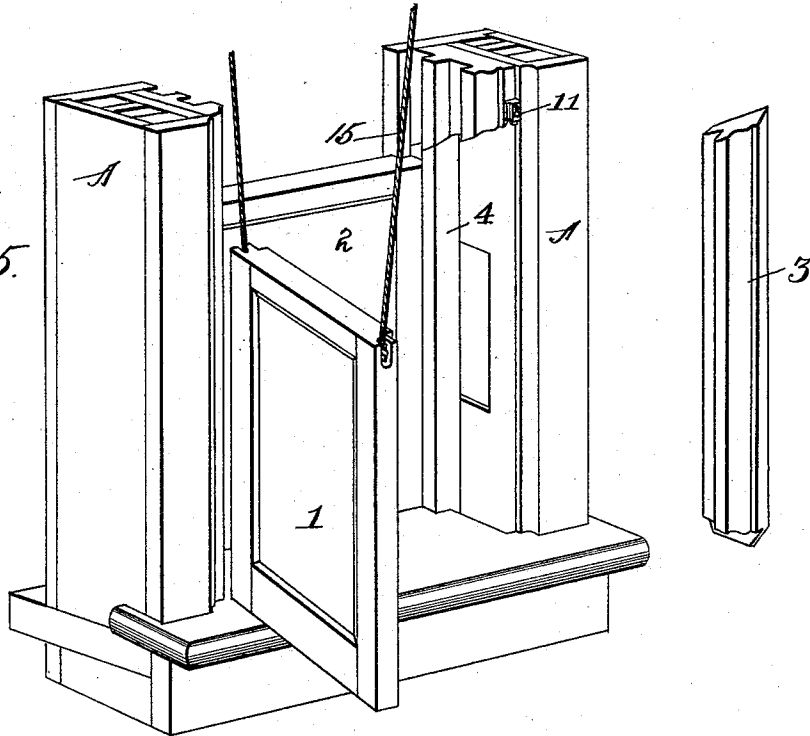
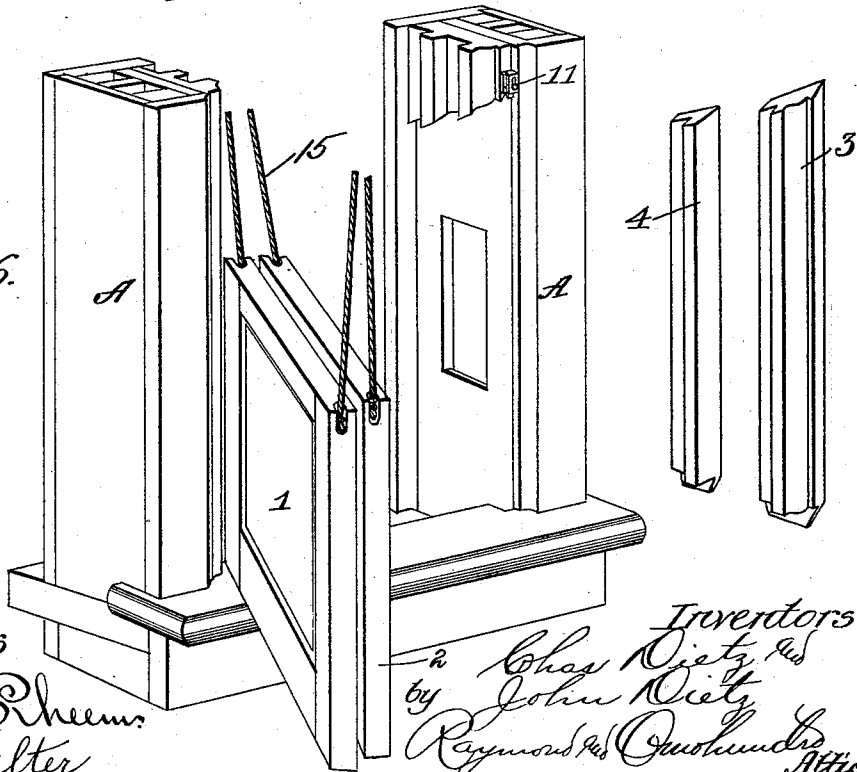

Fig. 6.



Witnesses
Wm. M. Rheum
Lew. Walter

Inventors
Chas. Dietz & Co.
by John Dietz
Raymond & Co. Attys

UNITED STATES PATENT OFFICE.

JOHN DIETZ AND CHARLES DIETZ, OF CHICAGO, ILLINOIS.

WINDOW ATTACHMENT.

SPECIFICATION forming part of Letters Patent No. 525,006, dated August 28, 1894.

Application filed May 22, 1893. Serial No. 475,003. (No model.)

To all whom it may concern:

Be it known that we, JOHN DIETZ and CHARLES DIETZ, citizens of the United States, and residents of Chicago, in the county of Cook and State of Illinois, have invented certain new and useful Improvements in Window Attachments, of which the following is a full, clear, and exact description, reference being had to the accompanying drawings, forming a part of this specification.

Our invention relates to appliances for enabling the sashes of windows to be swung inward, for cleaning, reglazing, painting, and similar work; thus avoiding the inconvenience and danger incident to the use of ladders or to standing or sitting upon the window-sills, while performing such work as has been mentioned.

Among the primary objects of our invention is included the provision of attachments whereby when the sashes are lowered they shall be automatically moved laterally so as to force the pivotal sides of the sashes outward from between the guide and partition strips at that side of the window-frame; thus avoiding all possibility of injury to the strips when the sashes are swung inward.

A further primary object of our invention is to produce attachments which will enable not only the lower sections of the partition and guide strips opposite the pivotal side of the sashes to be removed from the window-frame, but also the lower section of the window-jamb itself, thus permitting the described lateral movement of the sashes to take place without any impediment, and at the same time preserving a perfectly tight or weather-proof window.

To the above purposes, as well as to such others as may appear from the ensuing description, our invention consists in certain peculiar and novel features of construction and arrangement, as hereinafter described and claimed.

The more precise nature of our invention will be better understood when described with reference to the accompanying drawings, in which—

Figure 1 is an inner side elevation of a window-frame and its sashes having our attachments applied thereto; the sashes being in closed condition. Fig. 2 is a central trans-

verse vertical section of the same. Fig. 3 is a horizontal section of the window-frame; the sashes being both swung inward. Fig. 4 is a transverse vertical section of the lower part of a window-frame showing the removable jamb and strips. Fig. 5 is a perspective view of the lower part of a window-frame with the inner or upper sash swung inward and with the inner jamb-section removed; said jamb-section being shown at the right of the figure. Fig. 6 is a view similar to that of Fig. 5, but showing both sashes swung inward; and the two jamb-sections removed; said jamb-sections being shown at the right of the figure. Figs. 7 and 8 are transverse vertical sections of the lower parts of window-frames, showing different styles of removable jambs embodying our invention. Figs. 9, 10, and 11 are perspective views of the members of different forms of hinges embodying our invention. Fig. 12 is a transverse vertical section of the meeting-rails of the window-sashes, showing one of the pintle-sockets in the lower rail of the upper sash.

As will be seen from the ensuing description we employ in accordance with our invention hinges which are so constructed that, when the sashes are lowered, they are automatically forced outward from between the partition and guide strips at the hinge or pivotal side of the window-frame, and we also so construct the opposite lower part of the window-jamb that it can be previously removed bodily with its partition and guide strips, so as to afford space for the described lateral movement of the sashes; this outward lateral movement of the sashes preventing the strips at the hinge side of the frame or casing from being broken, or the edges of the sashes from being mutilated by the subsequent swinging of the sashes, and the removable character of the opposite jamb as well as the strips thereof, rendering the window absolutely weather-proof or tight when the jamb is in place.

Referring now in detail to the drawings, A designates a window frame or casing, which excepting in the particulars to be hereinafter specified, may be of the usual or any preferred type of construction; such casing having the usual lower or inner sash 1 and outer or upper sash 2 supported by the usual sash-cords 15, and movable upward and downward between

partition and guide strips 16 and 17 at the sides of the frame or casing A.

The terms "partition-strips" and "guide-strips" as used above and hereinafter in this specification, refer respectively to the middle strips which intervene between the two sashes, and to the outer and inner strips which in-

close said sashes.
At one side of the window-casing A are located hinges which are to be hereinafter fully described, and the partition and guide strips 3 and 4 at this side of the casing are secured permanently in position, and desirably extend continuously from bottom to top of the casing. The partition and guide strips at the opposite side of the casing are partly of a permanent and partly of a removable character relative to the window casing, those parts of the strips which extend from the top of the casing to a point slightly above the meeting-rails of the sashes when the sashes are closed, being secured permanently in position, while the remaining lower portions of the strips at this side of the casing, together with the corresponding parts of the jamb, are removable from the casing.

For the sake of clearness, we will first describe the removable jambs and their strip-sections, and then the hinges which embody our invention. These removable jambs are shown most clearly in Figs. 5, 6 and 9, and it is to be observed that the removable jamb-sections 9 carry with them the strip-sections 3 and 4.

It is to be observed that the line of separation between the upper end of the removable jamb and the lower end of the permanent jamb at that side of the casing may either extend obliquely upward and inward, as shown in Figs. 4, 5 and 6, or directly across the casing, horizontally, as shown in Figs. 7 and 8, and that in either event, the upper end of the removable jamb is desirably (although not necessarily) beveled upwardly, so as to better insure a tight fit when the jamb is in position; the lower end of the permanent jamb-section being of course correspondingly beveled.

It is to be still further understood that the removable jamb-section may either be in a single piece, carrying both the guide and partition strip sections, as shown in Figs. 4, 7 and 8, or in two sections, as shown in Figs. 5 and 6; the removable jamb-section or sections may be hinged to the window-casing, as indicated, in Fig. 8, at 20, or that the said removable jamb section or sections may be constructed in any desirable manner so as to be moved out of the way of the sashes, when the latter are to be swung inward. It will be clearly obvious that when the removable jamb-section is removed or moved so as to clear the adjacent sides of the sashes, ample space will be afforded to permit such a lateral movement of the lowered sashes as will throw the remote or hinged sides of the sashes outward from between the parting and guide-

strips at the hinge side of the casing, and also that no mere removability of the parting and guide strips only would afford such space.

We will now proceed to describe the hinges which we have provided for effecting automatically the described lateral movement of the sashes, and for supporting the sashes when the latter are swung inward. In Fig. 9, 5 designates the lower leaf of one of the hinges and 7 the upper companion leaf of the same. The lower leaves of these hinges are pivoted at the lower corners of their inner ends, as at 30, within recesses 31 formed in the lower part of the partition-strip 4 at the hinge side of the casing, and also in the lower part of the inner guide strip 3 at said side of the casing; the arrangement being such that when the hinges are not in use, the lower leaves can be turned upward into their recesses 31 and thus offer no impediment to the free upward and downward movement of the sashes. As shown in Fig. 3, the lower leaf of the outer hinge is longer than that of the inner hinge, so that when the sashes are swung inward they may lie closely side by side. Each lower leaf 5 is formed with a vertical socket-slot 32 extending from the outer end of the leaf inward to a considerable distance, and the outer side 8 of each lower leaf is inclined downwardly and inwardly, as shown in Fig. 9. The opposite or upper leaf 7 of the hinge is formed with a pendent pintle 6 the upper end of which is united to a lug 33 extending inwardly from the inner side of the hinge-leaf. One of these hinges is secured adjacent to the bottom of the sash and the other adjacent to the top of said sash (either the upper or lower sash, or both) when such sash is lowered, and it will be seen that as the sash is lowered, the pintles 6 will first enter the socket-slots 32 and that the lugs 33 will strike the inclined surfaces 8 and force the sash outward from between the adjacent parting and guide strips. Thus the sash may then be swung inwardly without breaking the parting or guide strips and without mutilating the edges of the sash. A hook-like lateral projection 34 is preferably formed on the lower end of the pintle 6, so that when the upper leaves move outward, the projections 34 shall engage beneath the outer ends of the lower hinge-leaves, and thus prevent the sash-weights from separating the leaves.

In Figs. 10 and 11 we have shown a simple modification of the hinge, but one which embodies precisely the same principles of construction as have just been set forth. In this instance the pintles 6^a corresponding to the pintles 6 are formed upon the outer ends of the lower hinge-leaves 5^a while the upper leaves are formed with elongated lugs 35 having each an elongated socket-slot 36 to receive the pintles. The inclined surfaces 8 are in this instance formed upon the lower hinge-leaf as before, and may either be straight, as at 8^a in Figs. 9 and 12, or curved, as at 8^b in Fig. 10. In any event, as the sashes are low-

ered, the lugs 35 strike the inclined surfaces 8^a or 8^b and force the sashes outward from between the parting and guide strips at the hinge side of the casing, and the lugs 34 of the pintles engage the ends of the lugs 35 and lock the hinge-sections together, as before. If desired, the sockets for the lower part of the upper sash may be formed directly in the under side of the ends of the lower rail of said sash; such sockets being widened inwardly to give the required play to the sash.

We have shown a hook 10 as attached to the removable-jamb side of the casing, so that, if desired, the sash cords may be disconnected from the sashes and attached temporarily to said hook. This device however forms no part of our present invention. It is of course preferable to remove the removable jamb-sections when the two sashes are in raised position, and then to lower the sashes so as to engage their hinge-leaves, after which the sashes can be readily swung inwardly as above described, without injury to the parting or guide strips at the hinge side of the casing, or to the edges of the sashes, at said side thereof.

Having thus described our invention, what we claim as new therein, and desire to secure by Letters Patent, is—

1. The combination with a window-casing, of a removable jamb-section located at one side of the casing, and supporting-hinges located at the opposite side of the casing and sash and each consisting of separable leaves one of which is provided with an incline for throwing the sash laterally into the space left by the removal of the removable jamb-section, substantially as set forth.

2. The combination with a window-casing, of a removable jamb-section located at one side of said casing and carrying portions of the corresponding guide and partition strips, and supporting-hinges located at the opposite side of the casing and sashes and each consisting of separable leaves one of which is provided with an incline for engaging the companion-leaf and forcing the sash laterally into the space left by the removal of the removable jamb-section and also outward from between the strips at the hinge side of the casing, substantially as set forth.

3. The combination with a window-casing, of separable hinges secured to one side of said casing and to the adjacent side of the sashes and each consisting of separable leaves one

of which is provided with an incline to engage the other leaf and to throw the sash laterally outward from between the strips at the hinge side of the casing; the pintle and the socket of said hinge-leaves moving horizontally relative to each other during said outward movement of the sash, substantially as set forth.

4. An attachment for windows, comprising a sash-supporting hinge composed of two leaves designed to be secured to corresponding sides of the sash and casing; one of the leaves having an incline for engaging the other leaf and forcing the sash outward from between the strips at the hinge side of the casing, the pintle and the socket of said hinge-leaves being moved laterally relative to each other during the said outward movement of the sash, substantially as set forth.

5. An attachment for windows, comprising a sash-supporting hinge composed of two leaves designed to be secured to corresponding sides of the casing and sash of a window; one of the leaves having an elongated socket and the other a pintle to enter said socket and the hinge being provided with an incline carried by one of the leaves and serving to engage the other leaf to throw the sash outward laterally from between the strips at the hinge side of the casing, and to move the pintle and the socket of said hinge-leaves horizontally relative to each other during said outward movement of the sash, substantially as set forth.

6. An attachment for windows, comprising a sash-supporting hinge composed of two separable leaves designed to be secured to corresponding sides of the casing and sash; one of said leaves having an elongated socket and the other a pintle to enter said socket, the end of the pintle being laterally protruded, and the hinge being also provided with an incline carried by one of the leaves and serving by engagement with the other leaf to throw the sash outward from between the strips at the hinge side of the casing, and to move the pintle and the socket of the hinge-leaves horizontally relative to each other during said outward movement of the sash, substantially as set forth.

JOHN DIETZ.
CHARLES DIETZ.

Witnesses:
TODD MASON,
V. HUGO.