



US 20190000251A1

(19) **United States**

(12) **Patent Application Publication**  
**Pathak**

(10) **Pub. No.: US 2019/0000251 A1**

(43) **Pub. Date: Jan. 3, 2019**

(54) **SYSTEM AND METHOD FOR STABILIZING UNINTENTIONAL MUSCLE MOVEMENTS**

(52) **U.S. Cl.**  
CPC ..... *A47G 21/08* (2013.01); *A47G 21/02* (2013.01); *A61F 2/08* (2013.01); *G16H 40/67* (2018.01); *A47G 2200/046* (2013.01); *A61F 4/00* (2013.01)

(71) Applicant: **Verily Life Sciences LLC**, Mountain View, CA (US)

(72) Inventor: **Anupam Pathak**, Los Altos, CA (US)

(57) **ABSTRACT**

(21) Appl. No.: **16/124,898**

A handheld system includes a motion-generating mechanism having a first motor mounted to a housing to generate a first rotary motion and a second motor coupled to a first output of the first motor such that the first rotary motion imparts to the second motor and rotates the second motor within the housing. The second motor generates a second rotary motion. An attachment arm extends out of the housing and has a first end coupled to a second output of the second motor and a second end configured to attach a user assistive device. A motion sensor senses a motion of the handheld system and generates a signal in response. A control system is coupled to receive the signal and to control the first and second rotary motions with commands generated based at least in part upon the signal. The commands direct the motion-generating mechanism to stabilize unintentional muscle movements.

(22) Filed: **Sep. 7, 2018**

**Related U.S. Application Data**

(63) Continuation of application No. 13/250,000, filed on Sep. 30, 2011.

**Publication Classification**

(51) **Int. Cl.**  
*A47G 21/08* (2006.01)  
*A47G 21/02* (2006.01)  
*A61F 4/00* (2006.01)  
*G16H 40/67* (2006.01)

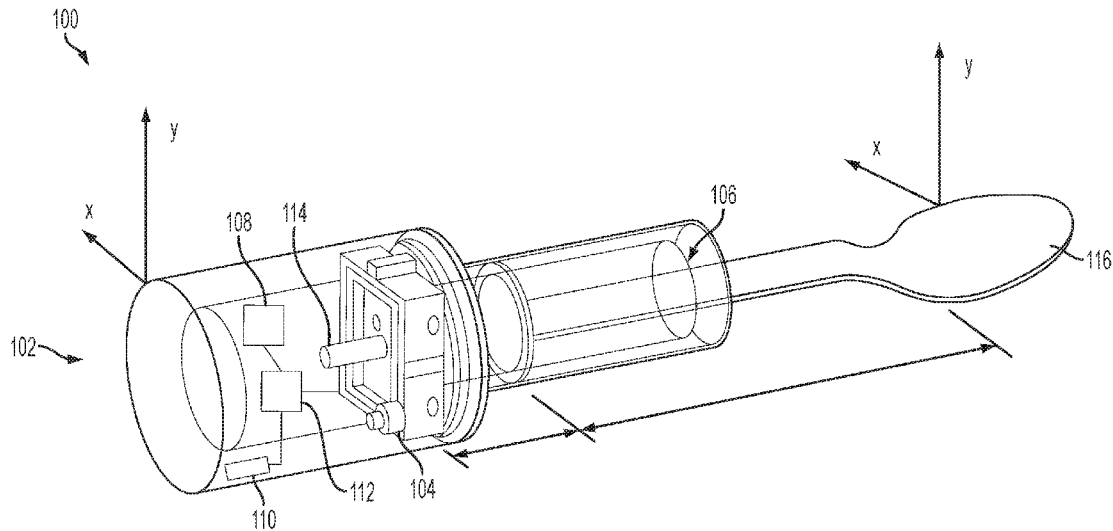

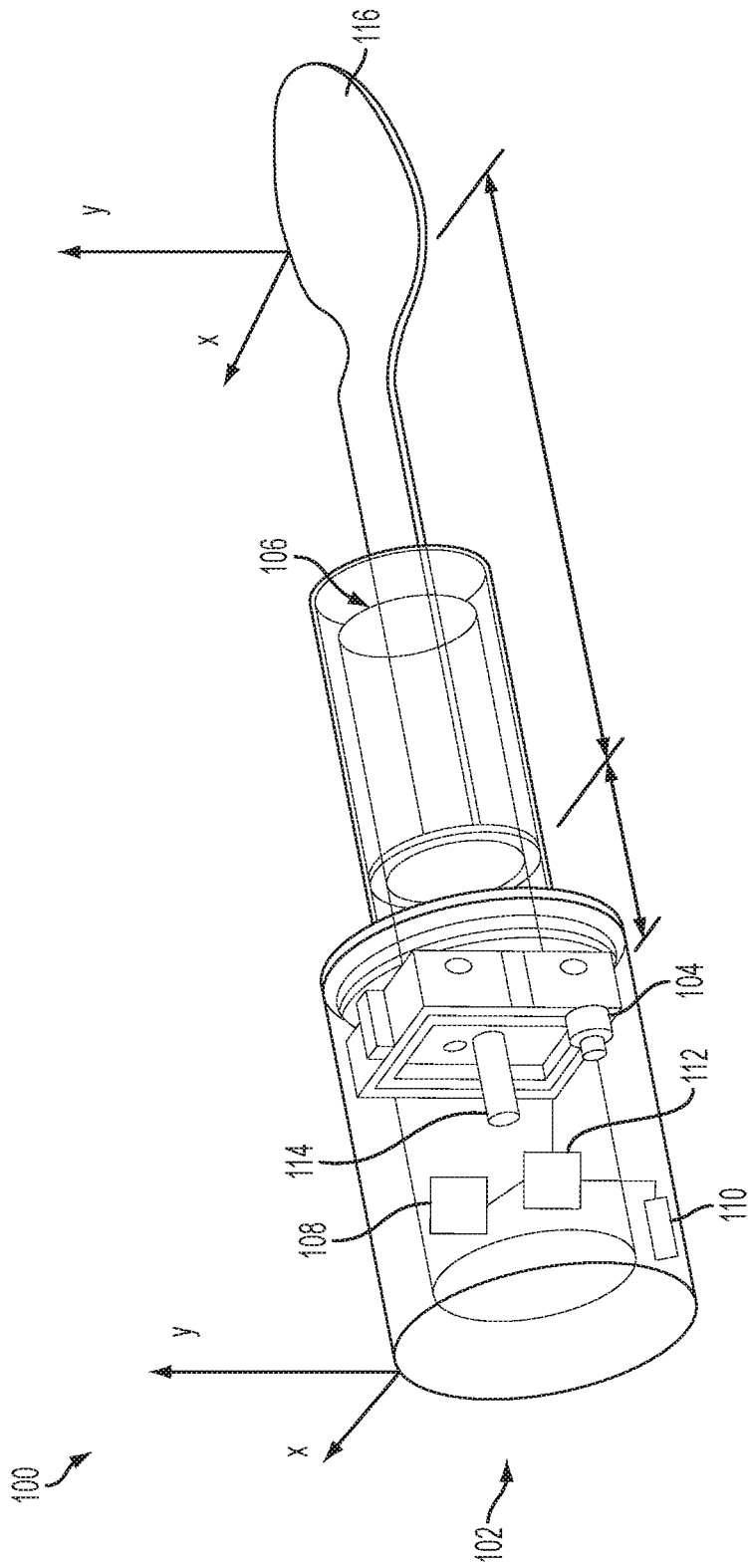

FIG. 1

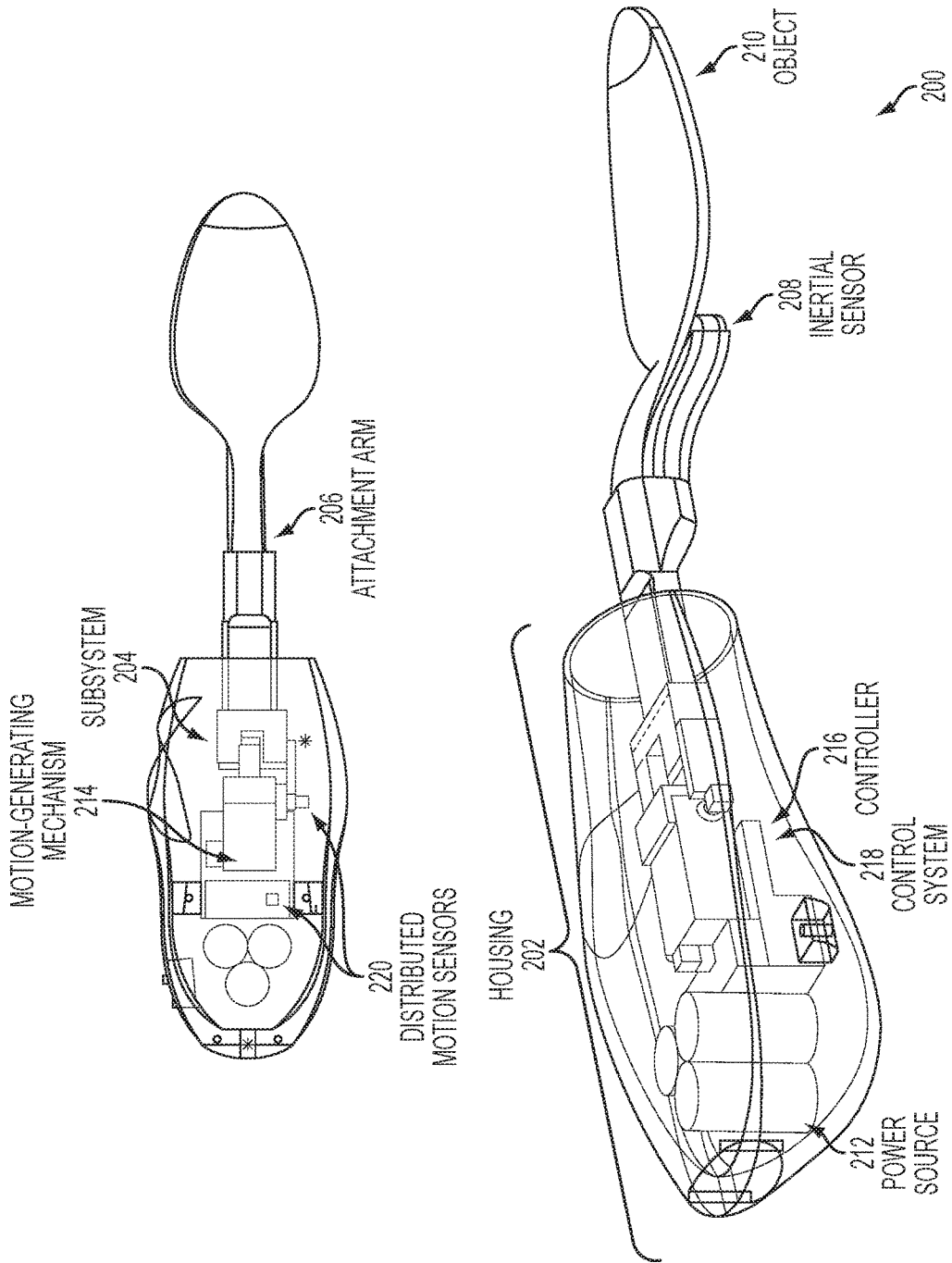

FIG. 2

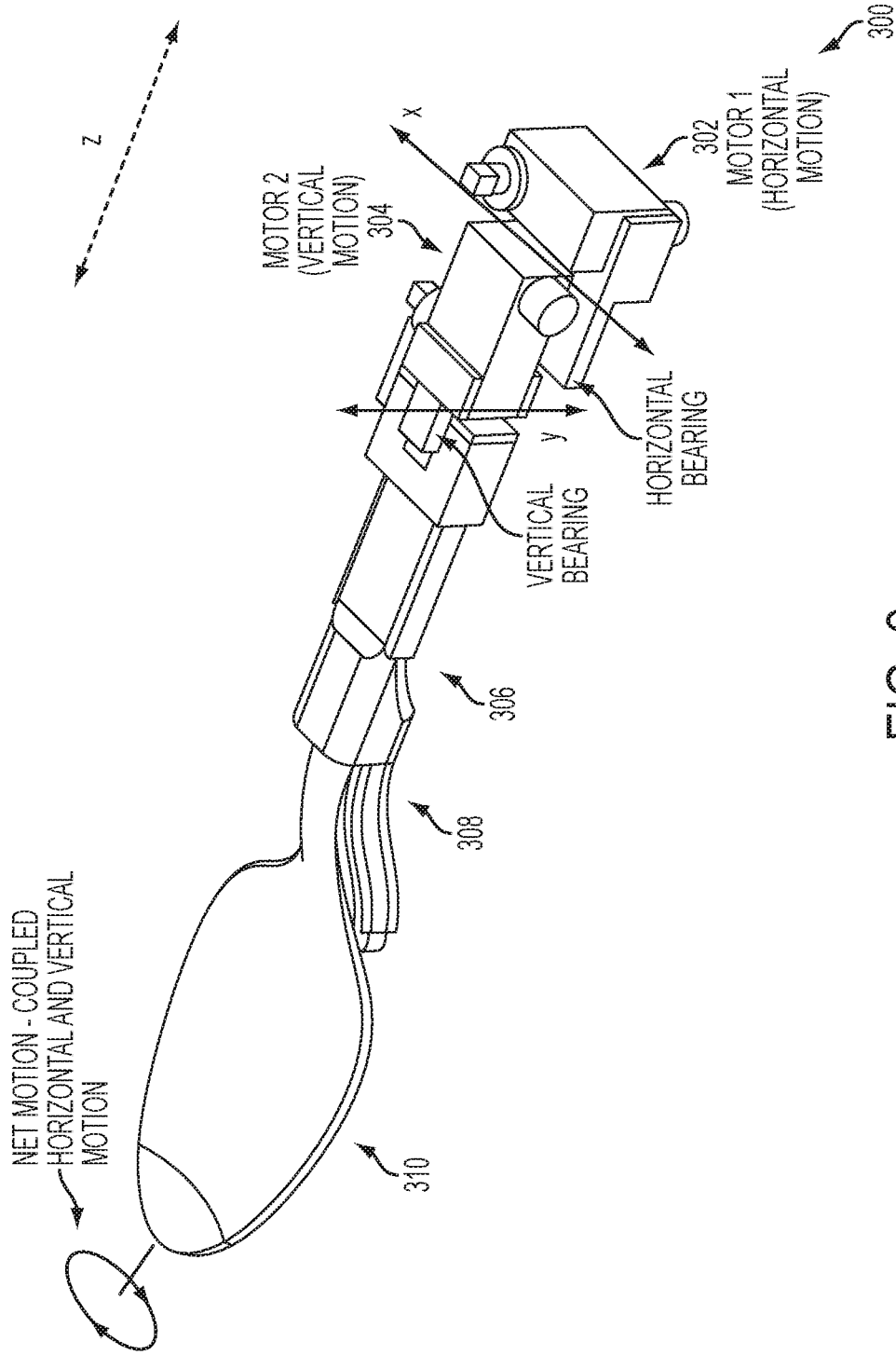

FIG. 3

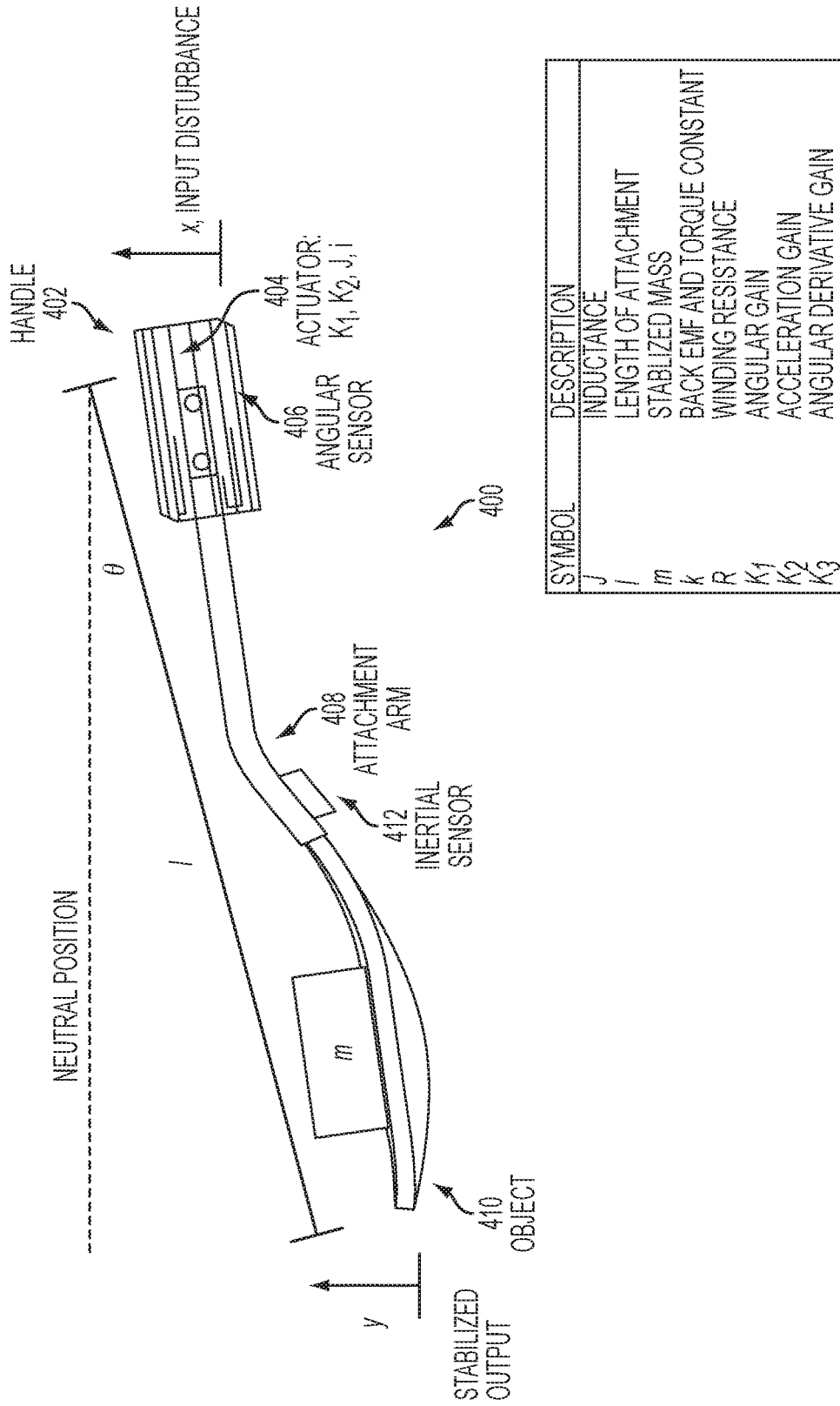

FIG. 4

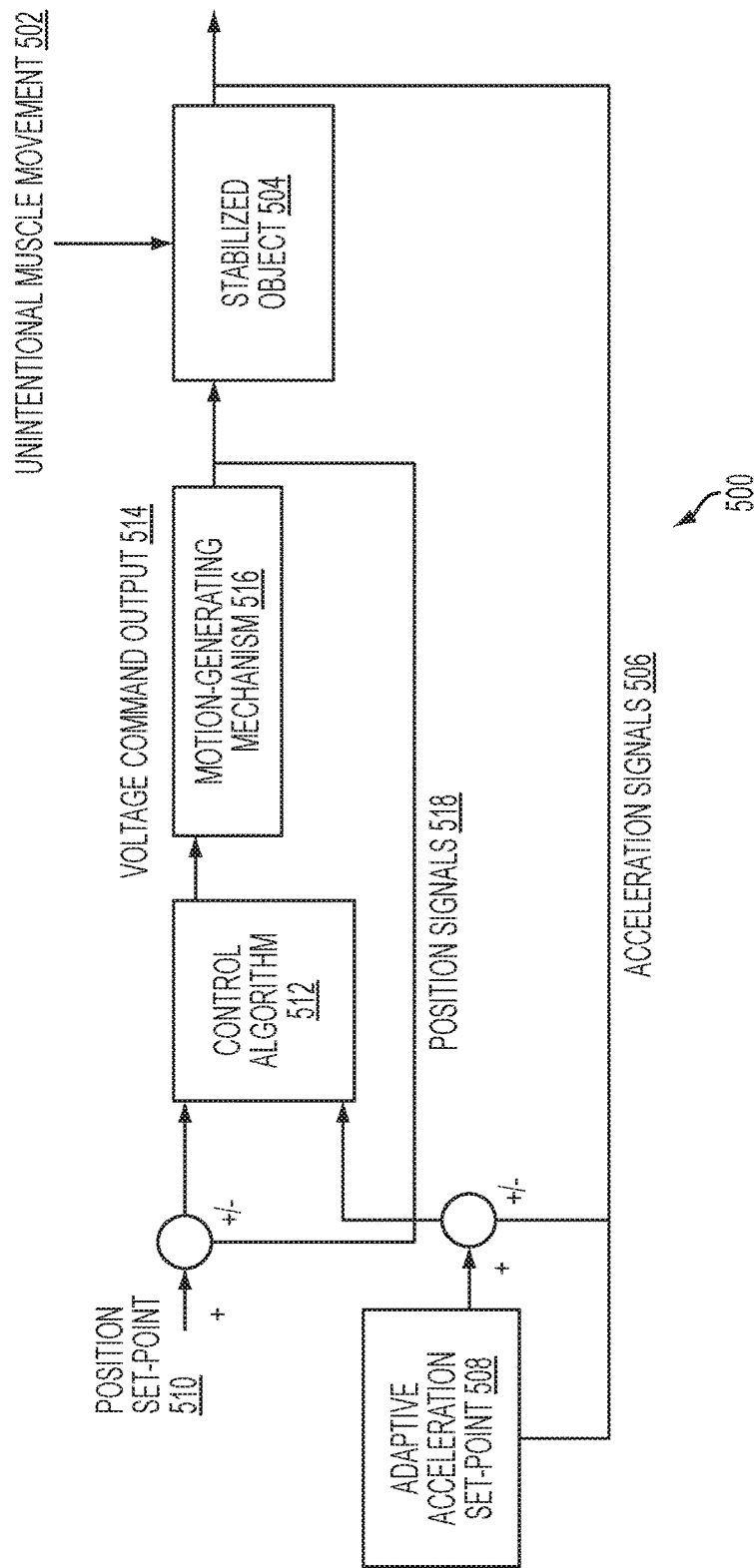

FIG. 5

## SYSTEM AND METHOD FOR STABILIZING UNINTENTIONAL MUSCLE MOVEMENTS

### CROSS-REFERENCE TO RELATED APPLICATION

**[0001]** This application is a continuation application of U.S. patent application Ser. No. 13/250,000, filed on Sep. 30, 2011, the contents of which are incorporated herein by reference.

### GOVERNMENT RIGHTS

**[0002]** This invention was made with Government support under grant No. NS070438 awarded by the National Institutes of Health (NIH). The Government has certain rights in the invention.

### FIELD OF THE INVENTION

**[0003]** The present invention relates generally to unintentional muscle movements of a body, and more particularly, to a system and method for stabilizing the effects of these unintentional muscle movements.

### BACKGROUND

**[0004]** Unintentional muscle movements of the human body, or human tremors, can occur in individuals suffering from neurological motion disorders including but not limited to Parkinson's Disease (PD) and Essential Tremor (ET). ET is the most common neurological motion disorder affecting as many as 10 million individuals in the United States and 270 million individuals worldwide. Due to the debilitating muscle movements associated with this disease, individuals with ET have difficulty in performing many daily functions such as eating and drinking. As a result, these individuals often suffer from social isolation, depression/anxiety, and an overall reduced Health Related Quality of Life (HRQoL).

**[0005]** Unintentional muscle movements of the human body can also occur in healthy individuals. These unintentional muscle movements are often exacerbated by environmental factors and situations that lead to fatigue, stress, nervousness, etc. For example, a military servicemember may experience unintentional muscle movements while performing a surgical operation on the battlefield due to stress and nervousness and this may result in decreased performance.

**[0006]** For individuals suffering from neurological motion disorders, a variety of treatment options exist. Pharmacological treatments vary in effectiveness, can lead to severe side effects and are unable to slow or stop disease progression. Surgical procedures, such as Thalamotomy and thalamic Deep Brain Stimulation (DBS) can be expensive, dangerous, and limited in availability. Non-invasive solutions, such as physically grounded tremor suppression devices, physically force a person's tremor to cease but require complex and costly structures, cause user discomfort and cannot differentiate between intended and unintended movements.

**[0007]** These issues limit the adoption of these treatments to select neurological motion disorder cases. Also, these treatments are often not available for healthy individuals suffering from human tremor. Thus, for the majority of individuals that suffer from human tremor, there is a strong need for a non-invasive solution that overcomes the above issues. The present invention addresses such a need.

### SUMMARY OF THE INVENTION

**[0008]** A system and method for stabilizing a position of an object are disclosed. In a first aspect, the system comprises a housing. The housing includes a subsystem. The system also includes an attachment arm coupled to the housing. At least one first sensor is placed along the attachment arm, wherein the attachment arm is configured to receive the object thereto. In response to an unintentional muscle movement by a user that adversely affects the motion of the object, the subsystem stabilizes the position of the object.

**[0009]** In a second aspect, the method comprises providing a subsystem within a housing and coupling an attachment arm to the housing. The method also includes placing at least one first sensor along the attachment arm, wherein the attachment arm is configured to receive the object thereto. In response to an unintentional muscle movement by a user that adversely affects the motion of the object, the subsystem stabilizes the position of the object.

### BRIEF DESCRIPTION OF THE DRAWINGS

**[0010]** The accompanying drawings illustrate several embodiments of the invention and, together with the description, serve to explain the principles of the invention. One of ordinary skill in the art readily recognizes that the particular embodiments illustrated in the drawings are merely exemplary, and are not intended to limit the scope of the present invention.

**[0011]** FIG. 1 illustrates a conventional handheld system that detects and compensates for unintentional muscle movements.

**[0012]** FIG. 2 illustrates a system that detects and compensates for unintentional muscle movements in accordance with an embodiment.

**[0013]** FIG. 3 illustrates a motion-generating mechanism in accordance with an embodiment.

**[0014]** FIG. 4 illustrates an analytical model in accordance with an embodiment.

**[0015]** FIG. 5 illustrates a system diagram of the control system in accordance with an embodiment.

### DETAILED DESCRIPTION OF PREFERRED EMBODIMENTS

**[0016]** The present invention relates generally to unintentional muscle movements in a body, and more particularly, to a system and method for stabilizing the effects of these unintentional muscle movements. The following description is presented to enable one of ordinary skill in the art to make and use the invention and is provided in the context of a patent application and its requirements. Various modifications to the preferred embodiment and the generic principles and features described herein will be readily apparent to those skilled in the art. Thus, the present invention is not intended to be limited to the embodiments shown but is to be accorded the widest scope consistent with the principles and features described herein.

**[0017]** FIG. 1 illustrates a conventional handheld system **100** that detects and compensates for unintentional muscle movements. The handheld system **100** includes a base **102**, a gripping element **106** coupled to the base **102**, and an object **116** (in this embodiment, a spoon) coupled to the gripping element **106**. The base **102** houses a stabilizing assembly using shape memory alloy (SMA) wires **104**, a

power source **108** coupled to the stabilizing assembly **104**, a single sensor **110** coupled to the power source **108**, a controller **112** coupled to the single sensor **110**, and a shaft **114** coupled to the stabilizing assembly **104**. SMA wires are alloy wires that, after deformation, undergo a phase change to return to their original cold-forged shape after sufficient heat is applied. The SMA wires utilized in the stabilizing assembly **104** are heated by the power source **108** to trigger this phase change.

[0018] In the handheld system **100**, the single sensor **110** is located within the base **102** to detect a user's motion and then the sensor **110** commands the stabilizing assembly using SMA wires **104** to produce a canceling motion. Unfortunately, several problems exist preventing the immediate use of SMA wires. For example, SMA wires have not been proven for long-term, reliable use and also require significant complexity and cost to provide sufficient motion to cancel large amplitude (1-4 cm) disabling tremors.

[0019] In addition, because the single sensor **110** is located within the base **102**, the use of the device is restricted to an object **116** that has a pre-determined length and weight that must be pre-programmed into the controller **112**. Deviations from this pre-determined length or weight will result in control instabilities and a reduction in the efficacy of the motion cancellation.

[0020] A system and method in accordance with the present invention addresses these drawbacks. The system and method include an inertial sensor placed along an attachment arm and a motion-generating mechanism that does not utilize SMA wires. In so doing, the motion of the varying stabilized objects can be directly measured and there is no need for pre-programming the pre-determined lengths and weights into the controller. Additionally, a higher performing handheld form-factor solution is achieved and the size and cost of the active cancellation system is further reduced. To describe the features of the present invention in more detail, refer now to the following description in conjunction with the accompanying Figures.

[0021] System Overview:

[0022] FIG. 2 illustrates a system **200** that detects and compensates for unintentional muscle movements in accordance with an embodiment. The system **200** includes a housing **202**. The housing **202** includes a subsystem **204**. The system **200** also includes an attachment arm **206** coupled to the housing **202**. At least one inertial sensor **208** is placed along the attachment arm **206**. The attachment arm **206** is configured to accept an object **210** thereto. The subsystem **204** further includes a portable power source **212**, a motion-generating mechanism **214**, a controller **216**, a control system **218**, and at least one distributed motion sensor **220**.

[0023] The attachment arm **206** can receive the object **210** in a variety of ways including but not limited to a friction, snap, or other form of locking mechanism. The portable power source **212** may utilize a variety of options including but not limited to a rechargeable battery and a solar panel. The operation and details of the elements of the at least one inertial sensor **208**, at least one distributed motion sensor **220**, motion-generating mechanism **214**, controller **216**, and control system **218** will be described in more detail hereinafter.

[0024] The at least one inertial sensor **208** and the at least one distributed motion sensor **220** detect unintentional muscle movements and measure signals related to these

unintentional muscle movements that are created when a user adversely affects motion of the object **210**. These sensors also detect the motion of the stabilized output relative to the housing **202**. The control system **218** sends voltage commands in response to the signals to the motion-generating mechanism **214** through the controller **216** to cancel the user's tremors or unintentional muscle movements. This cancellation maintains and stabilizes a position of the object **210**, keeping it centered relative to the housing **202**.

[0025] One of ordinary skill in the art readily recognizes that a system and method in accordance with the present invention may utilize various implementations of the controller **216**, at least one inertial sensor **208**, at least one distributed motion sensor **220**, and control system **218** and that would be within the spirit and scope of the present invention. In one embodiment, the controller **216** comprises an electrical system capable of producing an electrical response from sensor inputs such as a programmable microcontroller or a field-programmable gate array (FPGA). In one embodiment, the controller **216** comprises an 8-bit ATMEGA8A programmable microcontroller manufactured by Atmel due to its overall low-cost, low-power consumption and ability to be utilized in high-volume applications.

[0026] In one embodiment, the at least one inertial sensor **208** is a sensor including but not limited to an accelerometer, gyroscope, or combination of the two. In one embodiment, the at least one distributed motion sensor **220** is a contactless position sensor including but not limited to a hall-effect magnetic sensor. In one embodiment, the control system **218** is a closed-loop control system.

[0027] The closed-loop control system senses motion and acceleration at various points in the system **200** and feeds detailed information into a control algorithm that moves the motion-generating mechanism **214** appropriately to cancel the net effect of a user's unintentional muscle movements and thus stabilize the position of the object **210**. The operation and details of the elements of the control system and control algorithm will be described in more detail hereinafter.

[0028] Also, one of ordinary skill in the art readily recognizes that a system and method in accordance with the present invention may utilize a variety of objects including but not limited to kitchen utensils such as spoons and forks, grooming utensils such as make-up applicators, and various tools such as manufacturing, surgical and military tools. Thus, the system and method will be useful in not only improving the quality of life for the multitudes of individuals suffering from neurological motion disorders, but also in assisting in a variety of applications where physiological tremor is an issue including but not limited to manufacturing, surgical and military applications.

[0029] The system **200** stabilizes the object **210**'s position about a neutral position (selected to be  $\theta=0$ ) using the at least one inertial sensor **208**. To achieve this, the position of the object **210** must be sensed along with the angle  $\theta$ . For this position sensing, the at least one inertial sensor **208** is placed along the attachment arm **206** and is used to measure the absolute motion of the object **210** while providing low noise and sufficient sensitivity for the application. The direct sensor placement of the at least one inertial sensor **208** along the attachment arm **206** gives a unique advantage to the system **200** as it is extremely robust and does not rely on inverse kinematics/dynamics which may change depending

on usage. Thus, as aforementioned, a variety of objects can be used as the object **210** without the need to pre-determine and pre-program the length and weight of the object **210** into the controller **216**.

**[0030]** The at least one distributed motion sensor **220** is located within the housing **202** which is located at the base of the system **200**. The at least one distributed motion sensor **220** measures the relative motion of the attachment arm **206** relative to the housing **202**, wherein the object **210** is kept at a center position relative to the housing **202**. In one embodiment, the at least one distributed motion sensor **220** is at least one custom contactless hall-effect position sensor that provides angular feedback for the control system **218** and relies on a changing magnetic field that is dependent on the actuation angle.

**[0031]** The changing magnetic field is detected by a strategically placed integrated circuit (IC) located within the at least one distributed motion sensor **220**, whose analog output is read by the controller **216**, providing a completely non-contact angular detection that is capable of withstanding a large number of cycles. The at least one distributed motion sensor **220**, with its contactless sensing methods, provides significantly enhanced reliability over traditional direct-contact sensing methods such as potentiometers that wear over time.

**[0032]** Proper actuator operation is also a key to the overall operation of the system **200**. Actuator options include SMA wires, piezoelectrics, linear voice-coils and coreless motors. However, SMA wires, piezoelectrics and linear voice-coils suffer from various fundamental problems. For example, as noted in the “Fatigue Life characterization of shape memory alloys undergoing thermomechanical cyclic loading” article within the “Smart Structures and Materials” publication, SMA wires suffer from reliability issues where failures occur after  $10^4$  to  $10^5$  cycles with strain amplitudes between 8.3% and 4.4%, which would amount to only 200 days usage time. Piezoelectrics, while capable of longer cycle times, are fragile and expensive. In addition, they require high operating voltages and thus require relatively large and expensive drive electronics. Linear voice-coils operate at lower voltages but suffer from low force outputs and high costs.

**[0033]** The present invention addresses these drawbacks by using a combination of coreless micro-motors and miniature gear-reduction systems coupled to the coreless micro-motors using a coupling mechanism for the motion-generating mechanism **214**. In volume, coreless micro-motors are inexpensive and provide up to 1000 hours of operation time. Significant force of up to 10 newtons (N) can also be produced with these coreless micro-motors at the required tremor frequency of 0-5 hertz (Hz) through the use of a low-cost miniature gear-reduction system, with a total weight of only 6.5 grams (g). Furthermore, the power drawn from this technology is extremely low, estimated at 0.5 watts (W).

**[0034]** The coreless micro-motors are not only capable of holding a maximum load of 50 g while requiring 0.3 W of power, but are also capable of holding the lighter average filled tablespoon load of 14 g while requiring a significantly lower 0.06 W of power. Thus, the coreless micro-motors are suitable in generating the required forces for the system **200**.

**[0035]** FIG. 3 illustrates a motion-generating mechanism **300** in accordance with an embodiment. The motion-generating mechanism **300** includes a first miniature gear-reduc-

tion system coupled to a first coreless micro-motor **302** and a second miniature gear-reduction system coupled to a second coreless micro-motor **304**. At least one inertial sensor **308** is placed along an attachment arm **306**. The attachment arm **306** is configured to accept an object **310** thereto.

**[0036]** The first coreless micro-motor is capable of producing rotary motion in the horizontal (x) direction. This rotary motion is imparted to the second coreless micro-motor through a rigid connection that is supported by a horizontal bearing. The second coreless micro-motor is capable of producing motion in the vertical (y) direction. This motion from the second coreless micro-motor is supported by a vertical bearing.

**[0037]** A coupling mechanism is used to combine the horizontal and vertical motions of the two separate coreless micro-motor/miniature gear-reduction systems **302** and **304**. This combination results in a bi-directional circular motion of the object **310** (in this embodiment, a spoon). One of ordinary skill in the art readily recognizes that a system and method in accordance with the present invention may utilize a variety of coupling mechanisms including but not limited to sliding bearing mechanisms, gimbal structures, or bellows structures and that would be within the spirit and scope of the present invention.

**[0038]** In the motion-generating mechanism **300**, two degrees of freedom are generated from the two separate coreless micro-motor/miniature gear-reduction systems **302** and **304**. Additional degrees of freedom (e.g., a third in the z-direction) can be added to the motion-generating mechanism **300** by adding motion to the output of the first coreless micro-motor or the output of the second coreless micro-motor.

**[0039]** System Modeling:

**[0040]** To assist with the development of the control system type and parameter values, an analytical model of the system **200**'s properties was created. FIG. 4 illustrates an analytical model **400** in accordance with an embodiment. The analytical model **400** includes a handle **402**, an actuator **404**, an angular sensor **406**, an attachment arm **408**, an object **410**, and an inertial sensor **412**. The analytical model **400** was created with sufficient complexity to capture the dynamics of the system **200** and its response when synthesized with a closed-loop control system.

**[0041]** While the system **200** is designed to provide stabilization in multiple directions (e.g., vertical, horizontal, and the z-direction), analysis and modeling in only one direction is required because the motion outputs were symmetric and completely decoupled from one another. Thus, results from the vertical direction are directly applicable to other directions such as but not limited to the horizontal direction, assuming gravitational effects are negligible.

**[0042]** In the analytical model **400**, the object **410** moves in the vertical y direction. The tremor disturbance or unintentional muscle movement (coordinate x) is assumed to act directly on the handle **402**. The object **410** requiring stabilization (distance/from the base) moves a vertical distance y. This distance is related to the base coordinate x through the transformation,

$$y=x+\theta, \quad (1)$$

where small angles are assumed. The actuator **404** is capable of moving the object **410** through the angle  $\theta$  based on the

controller's voltage output. The output torque of the actuator 404's coreless motor T is proportional to its armature current i through the relationship

$$T=K_t i, \tag{2}$$

where  $K_t$  is a constant. Similarly, the back electromotive force (emf), e is related to the coreless motor's rotational velocity through

$$e=K_e \dot{\theta}. \tag{3}$$

[0043] For simplicity, and based on the manufacturer's specifications,  $K_e$  and  $K_t$  are approximately equal and are therefore set to a constant k. With the actuator 404's model Equations 2 and 3, the system equations can be constructed through a combination of Newton's and Kirchhoff's laws. Through a moment balance the dynamic equation is constructed as

$$I \ddot{\theta} + \frac{m l^2}{2} \ddot{\theta} = k i. \tag{4}$$

The second system equation is constructed as

$$J \frac{di}{dt} + R i = V - k \dot{\theta} \tag{5}$$

where V is the input voltage/command signal from the controller, J is the inductance of the actuator 404, and R is the internal resistance of the actuator 404.

[0044] The system 200 acts as a low-pass filter because it is designed to cancel high-frequency tremor disturbances/unintentional muscle movements while retaining low-frequency intended motions. Thus, the system 200 can be modeled as a transfer function, where an input amplitude X (tremor disturbance) is entered into the system 200, and an output Y (motion of the stabilized object) is observed and controlled.

[0045] For further analysis on tremor cancellation and to assist in controller design, the system Equations 4 and 5 were transformed into the frequency domain and manipulated to produce the desired transfer function. Using the coordinate transformation Equation 1 and performing a Laplace transform, Equations 4 and 5 were modified to produce

$$\frac{I}{7} s^2 (Y(s) - X(s)) + \frac{m l^2}{2} s^2 X(s) = k I(s) \tag{6}$$

and

$$J s I(s) + R I(s) = V - \frac{K s}{7} (Y(s) - X(s)). \tag{7}$$

[0046] Solving Equation 7 for I(s) and substituting the result into Equation 6 produces a single equation

$$\frac{I}{7} s^2 (Y(s) - X(s)) + \frac{m l^2}{2} s^2 X(s) = k \left( \frac{V - \frac{K s}{7} (Y(s) - X(s))}{J s + R} \right). \tag{8}$$

The remaining input in Equation 8 is V, which is the input voltage/command signal from the controller. This signal was designed to be simple in nature to minimize computational requirements and thus significantly reduce the cost and power consumption of the necessary microcontroller.

[0047] FIG. 5 illustrates a system diagram 500 of the control system 218 in accordance with an embodiment. The system diagram 500 includes an unintentional muscle movement 502, a stabilized object 504, acceleration signals 506, an adaptive acceleration set-point 508, a position set-point 510, a control algorithm 512, a voltage command output 514, a motion-generating mechanism 516, and position signals 518.

[0048] An unintentional muscle movement 502 by a user that adversely affects the motion of the stabilized object 504 is detected. Position signals 518 relative to the housing are measured by the at least one contactless position angular sensor and then are compared to the position set-point 510 that is stored in the microcontroller's memory (e.g., Electrically Erasable Programmable Read-Only Memory (EEPROM)). The position set-point 510 is the neutral position of the stabilized object 504 and is initially calibrated when the system 200 is first activated. This comparison results in a first input signal.

[0049] Acceleration signals 506 are measured by the at least one inertial sensor and then are compared to an adaptive acceleration set-point 508. The adaptive acceleration set-point 508 removes the effects of slow changes in the gravity field due to the changing orientation of the device. The adaptive acceleration set-point 508 can be implemented through the use of a median filter, low-pass filter, or other digital/analog filter capable of removing low frequencies from a signal. This comparison results in a second input signal.

[0050] The control algorithm 512 processes the first and second input signals and sends an appropriate voltage command output 514 to the motion-generating mechanism 516 in each controlled direction to actively cancel the user's unintentional muscle movement and maintain the stabilized object 504.

[0051] Based on these two input signals (acceleration signal and angle  $\theta$ ), a control law must be constructed for the control algorithm 512. One of ordinary skill in the art readily recognizes that a system and method in accordance with the present invention may utilize a variety of different control laws that provide tremor disturbance cancellation while ensuring stability of the object and that would be within the spirit and scope of the present invention.

[0052] For example, a control law can be derived by applying proportional and derivative gains to the angle  $\theta$  along with the acceleration signal resulting in

$$V=K_1 \theta - K_2 \dot{\theta} + K_3 \ddot{\theta}. \tag{9}$$

[0053] In this example, the feedback on the acceleration term provides the desired low-pass filtering properties. In the exemplified control law (Equation 9), the proportional feedback on the angle  $\theta$  is applied to allow the device to mimic the function of conventional implements. This is achieved by creating "stiffness" in the angular direction to allow the device to support various loads and while remaining in the neutral position during the inactive state. Derivative control on the angular input was selected for stability, particularly to dampen any resonances introduced by the

proportional feedback on  $\theta$ . The exemplified control law is both effective and computationally simple.

**[0054]** This allows the control algorithm **512** to be implemented in the highly compact, low-power, and low-cost microcontrollers of the system **200**. Substituting the exemplified control law (Equation 9) into V in Equation 8 and expanding the terms allows Equation 8 to be expressed as the following transfer function

$$\frac{Y(s)}{X(s)} = \frac{n}{d} \quad (10)$$

where the numerator is

$$n = (2ILP^2 - mL^3P^2)s^4 + (4ILJR - 2mL^3JR)s^3 + (2K^2LJ + 2K_3K_LJ - mL^3R^2 + 2ILR^2)s^2 + (2K^2LR + 2K_1KLJ + 2K_3K_LR)s + 2K_1K_LR \quad (11)$$

and the denominator is

$$d = (2ILP^2)s^4 + (2K_2KL^2J + 4ILJR)s^3 + (2K^2LJ + 2K_2KL^2R + 2K_3K_LJ + 2ILR^2)s^2 + (2K^2LR + 2K_1KLJ + 2K_1K_LR)s + 2K_1K_LR \quad (12)$$

**[0055]** To reject unintentional muscle movements while retaining intended motions, the parameters of the exemplified control law (Equation 9) are optimized through numerical simulation. For example, this optimization minimizes the average displacement magnitude of the stabilized object **504** (Y, Equation 10) over the unintentional muscle movement frequency range of 3-7 Hz, while varying the controller gains  $K_1$ ,  $K_2$ ,  $K_3$ . Further, in this example, the constraints are defined such that low-frequency motions in the intended motion frequency range of 0-1 Hz are unaffected and stability is mathematically ensured. The average phase lag is also constrained to be less than 15 degrees from 0-1 Hz, which is assumed to be unnoticeable to the user.

**[0056]** For the optimization, computational functions are written to interact with the trust-region reflective optimization algorithm `fmincon` in Matlab. The algorithm is run to provide a final solution,  $K = [121, 366, 154]$ , which is used for the controller **216** in the system **200**. The function has a minimum value of 0.15, which means that the system **200** is capable of filtering on average 80% of the input tremor disturbances/unintentional muscle movements in the frequency range of 3-7 Hz.

**[0057]** As above described, the system and method in accordance with the present invention allow for a highly compact active cancellation approach that seeks to accommodate a user's tremor by allowing it to exist while cancelling its effects and stabilizing the position of the object. By implementing a motion-generating mechanism to provide the necessary forces and displacements for tremor cancellation and a control system and sensor topology to control this motion-generating mechanism, the system and method in accordance with the present invention achieve a more robust handheld form-factor with a significantly reduced size and cost.

**[0058]** Although the present invention has been described in accordance with the embodiments shown, one of ordinary skill in the art will readily recognize that there could be variations to the embodiments and those variations would be within the spirit and scope of the present invention. Accordingly, many modifications may be made by one of ordinary

skill in the art without departing from the spirit and scope of the appended claims.

1. A handheld system, comprising:

a housing shaped for holding by a hand, the housing including an open end;

a motion-generating mechanism at least partially disposed within the housing, the motion-generating mechanism including:

a first motor mounted to the housing and adapted to generate a first rotary motion about a first axis; and

a second motor mounted within the housing and coupled to a first output of the first motor such that the first rotary motion output from the first motor is imparted to the second motor and rotates the second motor within the housing, the second motor adapted to generate a second rotary motion about a second axis different from the first axis;

an attachment arm extending through the open end of the housing and having first and second ends, the first end coupled to a second output of the second motor and the second end configured to attach a user assistive device, wherein the attachment arm is movable relative to the housing in two degrees of freedom;

a motion sensor adapted to sense a motion of the handheld system and generate a feedback signal in response to the motion; and

a control system disposed within the housing and coupled to the motion sensor to receive the feedback signal from the motion sensor, the control system further coupled to the motion-generating mechanism and configured to control the first and second rotary motions with commands generated based at least in part upon the feedback signal from the motion sensor, wherein the commands direct the motion-generating mechanism to move the attachment arm relative to the housing to stabilize unintentional muscle movements of the housing.

2. The handheld system of claim 1, wherein the motion-generating mechanism further comprises:

a first bearing supporting a first connection between the second motor and the first output of the first motor; and

a second bearing supporting a second connection between the first end of the attachment arm and the second output of the second motor,

wherein the first and second bearings are substantially orthogonal to each other.

3. The handheld system of claim 1, wherein the motion-generating mechanism further comprises:

a first gear reduction system coupled to the first output of the first motor; and

a second gear reduction system coupled to the second output of the second motor.

4. The handheld system of claim 1, wherein the motion sensor is disposed within the housing.

5. The handheld system of claim 4, wherein the motion sensor comprises a relative-motion sensor mounted within the housing to sense a relative motion between the housing and the attachment arm.

6. The handheld system of claim 5, wherein the relative-motion sensor comprises a contactless magnetic sensor.

7. The handheld system of claim 1, wherein the motion sensor comprises an absolute-motion sensor attached directly to the attachment arm between the first and second ends to sense an absolute motion of the attachment arm.

8. The handheld system of claim 7, wherein the absolute-motion sensor comprises an inertial sensor.

9. The handheld system of claim 7, further comprising: a relative-motion sensor mounted within the housing to sense a relative motion between the housing and the attachment arm, wherein the control system is configured to generate the commands for stabilizing the unintentional muscle movements based upon feedback from the absolute-motion sensor and the relative-motion sensor.

10. The handheld system of claim 1, wherein the user-assistive device comprises any of a kitchen utensil or a grooming utensil.

11. The handheld system of claim 1, wherein the attachment arm is configured to attach the user assistive device via a friction mechanism or a snap mechanism.

12. A handheld system, comprising:  
a housing shaped as a handle for holding;  
a motion-generating mechanism at least partially disposed within the housing, the motion-generating mechanism including:

a first motor mounted to the housing and adapted to generate a first rotary motion; and

a second motor coupled to a first output of the first motor such that the first rotary motion output from the first motor is imparted to the second motor and rotates the second motor within the housing, the second motor adapted to generate a second rotary motion;

an attachment arm extending out of the housing and having first and second ends, the first end coupled to a second output of the second motor and the second end configured to attach a user assistive device;

an absolute-motion sensor disposed directly on the attachment arm between the first and second ends and adapted to sense an absolute motion of the attachment arm and to generate a first signal in response; and

a control system disposed within the housing and coupled to the absolute-motion sensor to receive the first signal, the control system further coupled to the motion-generating mechanism and configured to control the first and second rotary motions with commands generated based at least in part upon the first signal, wherein the commands direct the motion-generating mechanism to move the attachment arm relative to the housing to stabilize unintentional muscle movements of the housing.

13. The handheld system of claim 12, wherein the motion-generating mechanism further comprises:

a first bearing supporting a first connection between the second motor and the first output of the first motor; and  
a second bearing supporting a second connection between the first end of the attachment arm and the second output of the second motor,

wherein the first and second bearings are substantially orthogonal to each other.

14. The handheld system of claim 12, wherein the motion-generating mechanism further comprises:

a first gear reduction system coupled to the first output of the first motor; and

a second gear reduction system coupled to the second output of the second motor.

15. The handheld system of claim 12, further comprising: a relative-motion sensor disposed in the housing to measure a relative motion between the housing and the attachment arm and to generate a second signal in response,

wherein the control system is further coupled to the relative-motion sensor to receive the second signal and configured to control the first and second rotary motions with the commands generated based at least in part upon the first signal and the second signal.

16. The handheld system of claim 15, wherein the relative-motion sensor comprises a contactless magnetic sensor.

17. (canceled)

17. The handheld system of claim 12, wherein the user-assistive device comprises any of a kitchen utensil or a grooming utensil.

18. The handheld system of claim 12, wherein the attachment arm is configured to attach the user assistive device via a friction mechanism or a snap mechanism.

19. A handheld system for stabilizing human tremors, comprising:

a housing;

a motion-generating mechanism at least partially disposed within the housing, the motion-generating mechanism including:

a first motor mounted to the housing and adapted to generate a first rotary motion; and

a second motor coupled to a first output of the first motor such that the first rotary motion output from the first motor is imparted to the second motor and rotates the second motor within the housing, the second motor adapted to generate a second rotary motion;

an attachment arm extending out of the housing and having first and second ends, the first end coupled to a second output of the second motor within the housing and the second end attached to a user assistive device;

a motion sensor disposed within the housing and adapted to sense a motion of the handheld system and to generate a first signal in response to the motion; and

a control system disposed within the housing and coupled to the motion sensor to receive the first signal, the control system further coupled to the motion-generating mechanism and configured to control the first and second rotary motions with commands generated based at least in part upon the first signal, wherein the commands direct the motion-generating mechanism to move the attachment arm relative to the housing to stabilize the user assistive device from the human tremors of the housing.

20. The handheld system of claim 19, wherein the motion-generating mechanism further comprises:

a first bearing supporting a first connection between the second motor and the first output of the first motor; and

a second bearing supporting a second connection between the first end of the attachment arm and the second output of the second motor,

wherein the first and second bearings are substantially orthogonal to each other.