

J. JAEGER.  
Fire Place Stove.

No. 109,909.

Patented Dec. 6, 1870.

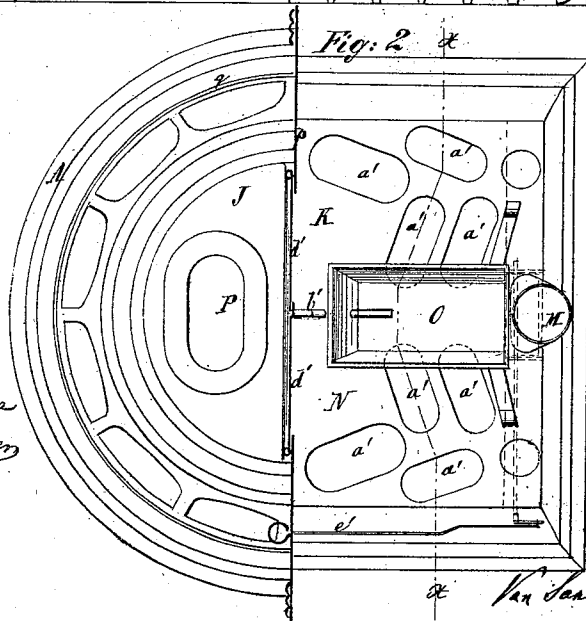
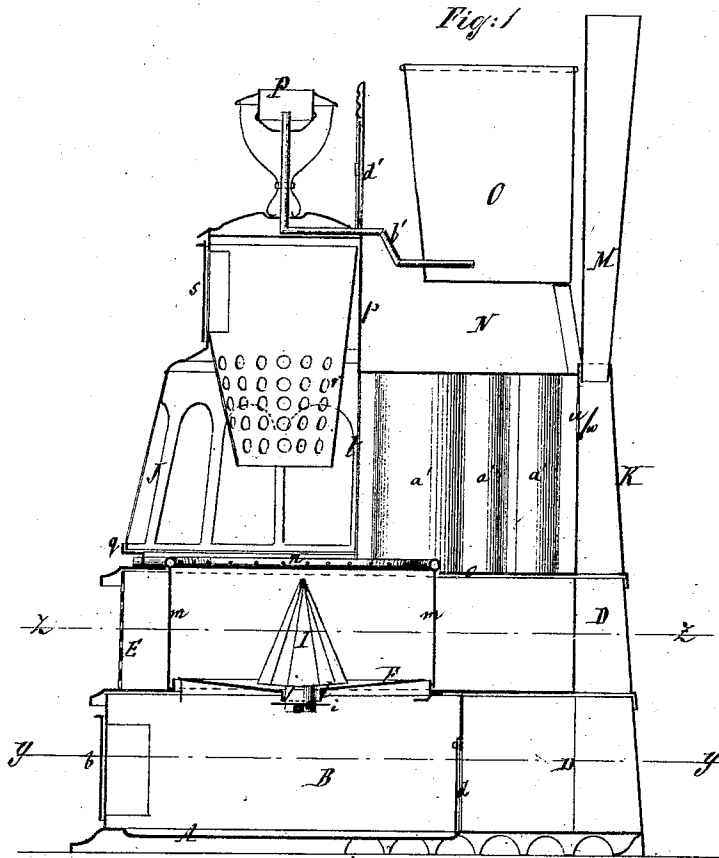

Witnesses.  
*S. Mahlers*  
*E. F. Hastenhuber*

Inventor.

*Julius Jaeger*

*Van Santwood & Hauff*

J. JAEGER.  
Fire Place Stove.

No. 109,909.

Patented Dec. 6, 1870.

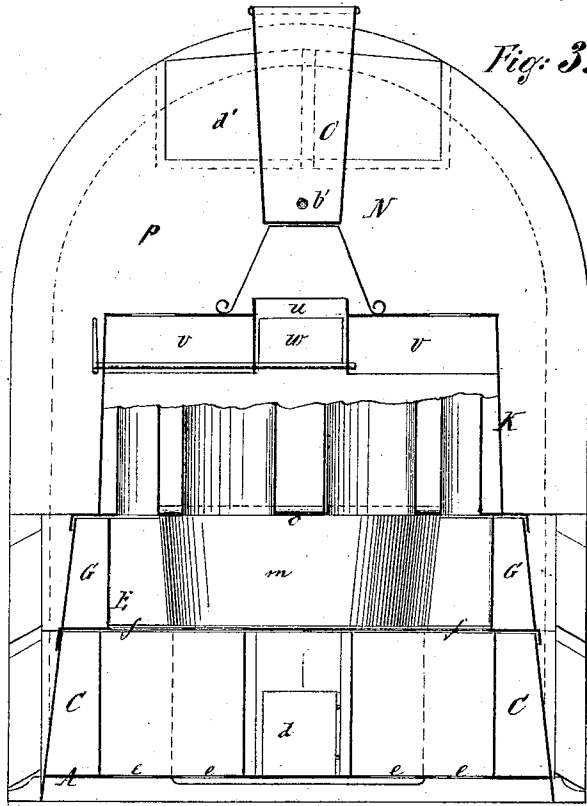

Fig. 3.

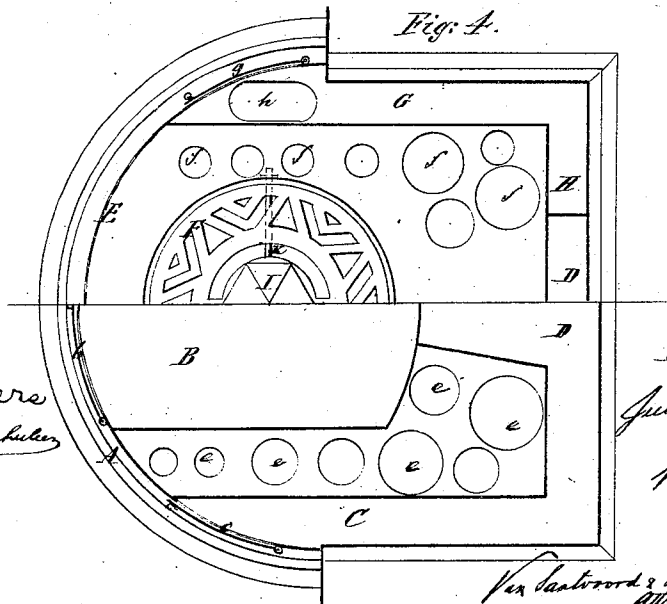

Fig. 4.

Witnesses.  
C. Wähler  
E. F. Hartenbuler

Inventor:  
Julius Jaeger

Via Santwood & Hauff  
1871

# United States Patent Office.

JULIUS JAEGER, OF TOMPKINSVILLE, NEW YORK.

Letters Patent No. 109,909, dated December 6, 1870.

## IMPROVEMENT IN BASE-BURNING FIRE-PLACE HEATERS.

The Schedule referred to in these Letters Patent and making part of the same.

To all whom it may concern:

Be it known that I, JULIUS JAEGER, of Tompkinsville, in the county of Richmond and State of New York, have invented a new and useful Improvement in Fire-place Heaters; and I do hereby declare the following to be a full, clear, and exact description thereof, which will enable those skilled in the art to make and use the same, reference being had to the accompanying drawing forming part of this specification, in which drawing—

Figure 1 represents a vertical section of my heater from front to rear.

Figure 2 is a plan or top view of the same.

Figure 3 is a vertical cross-section of the same, the line *x x*, fig. 2, indicating the plane of section.

Figure 4 is a horizontal section of the same, the upper part of said figure being bisected in the plane indicated by the line *z z*, and the lower part in the plane indicated by the line *y y*, fig. 1.

Similar letters indicate corresponding parts.

This invention relates to a fire-place heater the front or fire part of which is separated by a frame from the hind or air-heating part in such a manner that the front part can be readily removed without disturbing the rear part, and that easy access can be had to the interior of the heater for the purpose of cleaning or repairing, said partition or frame being provided with doors, which can be opened after the front part of the heater has been removed.

On the top of the front part is placed a water-urn, which communicates, by means of a pipe, with a vessel situated on the inner or rear part of the heater in such a manner that, by pouring water into the urn, the level of the water in the inner vessel can be observed and controlled at all times without removing or disturbing any part of the heater.

The heater is provided with a perforated reservoir for the fuel, and with a distributing cone, which is situated in the center of the grate and rocks with the same, so that the fuel on dropping down on said cone is uniformly distributed over the grate, and by shaking the grate the fuel is prevented from clogging up the reservoir and the fire is readily cleaned.

In the back part of the heater is a damper, and if this damper is open the draught passes direct up through the smoke-pipe; but if said damper is closed the draught passes down through lateral vertical flues into side flues forming the sides of the fire-place, and thence down into the lower side flues which form the sides of the ash-pan, and which communicate, by means of a central upright flue, with the smoke-stack, and as the heated-gases are thus compelled to circulate round the entire stove a large body of air is heated to a high temperature with great economy in fuel.

The air-pipes are oval, so as to increase their heating surface as compared with the quantity of air passing through them, and they are placed in oblique positions toward each other, so that the heated gases are compelled to impinge against their flat sides, and the air passing up through said pipes is rapidly heated to a high temperature.

In the drawing the letter A designates the base of my heater, which is occupied by the ash-pan B, the lower side flues C, and the central upright flue D, (best seen in the lower half of fig. 4,) access being had to the ash-pan through a door, *b*, to the lower side flues through doors *c*, while a door, *d*, figs. 1 and 3, leads from the ash-pan in the central upright flue.

The spaces between the lower side flues and the ash-pan communicate, by means of holes, *e*, with the external air.

On the base A rests the middle part E of my heater, which is partly occupied by the grate F and the upper side flues G, while the spaces between the grate and said upper side flues communicate with the spaces below through holes *f*, (best seen in the upper half of fig. 4.)

Access is had to the upper side flues through doors *g*, and holes *h* lead from these upper side flues down to the lower side flues, while they communicate through vertical back flues H with the next part above, as will be presently explained.

The grate F is circular in form and slightly concave, and it rests upon a pin, *i*, (see fig. 1,) which passes through the shank *j* of a cone, I, that is mounted on the rock-shaft *k*, the grate being provided with a central hub, *l*, which embraces the shank of the cone so that said grate can be turned independent of the cone; but if a rocking motion is imparted to the cone, this motion is communicated to the grate.

The upper part of my heater is composed of two parts, J and K, and from the base-plate *o* of this part extends a circular flange, *m*, in a downward direction far enough to embrace the rim of the grate if the heater is in position.

This circular flange, together with the grate, form the fire-place of my heater, and round the upper edge of said circular flange extends a perforated pipe, *n*, which communicates with the external atmosphere, (see fig. 1,) so as to throw jets of air into the gases rising from the fire-place for the purpose of consuming said gases.

From the base-plate *o* rises a vertical partition-plate, *p*, which is intended to lie close against the wall of the chimney, and which separates the front part J from the back part K.

The front part J is placed loosely upon the base-plate *o*, which is provided with a confining flange, *q*, serving to retain said front part in position.

In said front part is secured the fuel-reservoir *r*, to which access is had through doors *s*, and which is perforated with a large number of holes, (see fig. 1.) so that the gases evolved from the fuel in the reservoir are free to escape in the combustion-chamber *t*, where the same are consumed, and all danger of an explosion is thereby avoided.

The combustion-chamber *t* occupies the lower portion of the front part *J* and the whole of the back part *K*, and it communicates through aperture *u* with the central upright flue *D*, which communicates with the smoke-pipe *M*, (see fig. 1.) and through lateral apertures *v*, with the back flues *H*, (see fig. 3.)

The aperture *u* can be opened or closed by means of a damper, *w*.

Through the combustion-chamber extend the air-flues *a'*, which are made oval (see fig. 2) and placed in oblique positions toward each other, so that the heated gases rising from the fire are compelled to impinge against the flat sides of said flues, and thereby the heating effect is materially increased.

When the damper *w* is open the draught passes right up through the aperture *u* to the smoke-pipe, but after the fire in the heater is going said damper can be closed, and then the draught is compelled to pass from the combustion-chamber through the lateral aperture *v* into the lateral back flues *H*, thence through the upper side flues *G* and apertures *h* into the lower side flues *C*, and through them and the central vertical flue *D* up to the smoke-pipe.

By causing the heated gases to circulate in this manner round the air-spaces *e* and *f* the air passing up through said air-spaces is heated before it reaches the air-flues *a'*, and a great economy in fuel is effected.

The heated air emanating from the air-flues *a'* passes up through the main air-flue *N* into the upper part of the building.

In this main air-flue is situated a water-vessel, *O*, which is designed to hold water for moistening the heated air, and communicates, by means of a pipe, *v'*,

with a feed-cup, *P*, placed on the top of the front part *J*, (see fig. 1.)

This feed-cup is situated at a level a little below the top of the vessel *O*, so that if the feed-cup is filled up the water in the vessel *O* will not overflow.

By observing the level of the water in the feed-cup a sufficient supply of water can always be kept in the vessel *O* without opening or removing the partition-plate *p*.

In the partition-plate *p* are doors, *d'*, which can be opened when the front part *J* of the heater has been removed, and thus ready access can be had to the main air-flue for the purpose of cleaning or repairing.

The damper *w* is operated by a rod, *e'*, extending through the partition-plate *p*.

What I claim as new, and desire to secure by Letters Patent, is—

1. The combination of the feed-cup *P*, pipe *v'*, and water-vessel *O*, substantially in the manner shown and described.

2. The oval air-pipes *a'*, arranged in the combustion-chamber of a heater in oblique positions toward each other, as and for the purpose set forth.

3. The back flues *H*, upper side flues *G*, apertures *h*, lower side flues *C*, and central back flue *D*, in combination with the combustion-chamber of a heater constructed and arranged substantially as described.

4. The doors *d'* in the vertical partition *p*, in combination with the front part *J* and back part *K* of a fire-place heater constructed substantially as set forth.

5. The grate *F*, formed with hub *l* encircling the shank of the cone *I*, in connection with the pin *i* passing through said shank, and with the rock-shaft *K*, on which the cone is mounted, substantially as and for the purpose described.

This specification signed by me this 3d day of June, 1870.

Witnesses:

W. HAUFF,

E. F. KASTENHUBER.

JULIUS JAEGER.