



US00D826428S

(12) **United States Design Patent**
Schuette

(10) **Patent No.:** **US D826,428 S**

(45) **Date of Patent:** **** Aug. 21, 2018**

- (54) **CARPORT**
- (71) Applicant: **Luke Dean Schuette**, Springfield, IL (US)
- (72) Inventor: **Luke Dean Schuette**, Springfield, IL (US)
- (73) Assignee: **Luke Schuette**, Chatham, IL (US)

3,869,836 A * 3/1975 Allen E04B 1/34336
52/146
3,964,404 A * 6/1976 Mueller A47B 57/265
108/147.14
D270,570 S * 9/1983 Schildge, Jr. D25/1
D280,343 S * 8/1985 Schultz D25/1
D293,934 S * 1/1988 Lambert D25/56
7,913,710 B2 * 3/2011 Bougioukos E04H 6/025
135/87

(Continued)

(**) Term: **15 Years**

FOREIGN PATENT DOCUMENTS

(21) Appl. No.: **29/572,947**

IT 0000095285-0034 * 5/2007

(22) Filed: **Aug. 1, 2016**

OTHER PUBLICATIONS

(51) **LOC (11) Cl.** **25-03**

(52) **U.S. Cl.**
USPC **D25/61; D25/56**

<http://www.bmwblog.com/2016/05/30/americas-cup-team-high-lights-bmw-solar-carport/> Posted May 30, 2016.*

(Continued)

(58) **Field of Classification Search**
USPC D25/16, 17, 23, 30, 32, 34, 55, 56, 57,
D25/61; 52/23, 56, 73, 146, 295, 296,
52/DIG. 11
CPC E04H 1/1211; E04H 6/00; E04H 6/02;
E04H 6/025; E04H 15/18; E04H 15/34;
E04H 15/46; E04H 15/58; H02S 20/00;
F24J 2/38

Primary Examiner — Susan B Hattan
Assistant Examiner — Leanne D Was-Englehart
(74) *Attorney, Agent, or Firm* — Sandberg Phoenix & von Gontard P.C

See application file for complete search history.

(57) **CLAIM**

The ornamental design for a carport, as shown and described.

(56) **References Cited**

U.S. PATENT DOCUMENTS

D185,579 S * 6/1959 Sklar D25/18
D187,522 S * 3/1960 Hinsch D25/125
2,974,449 A * 3/1961 Leeper E04B 1/346
297/184.15
D192,212 S * 2/1962 Schlager D25/34
D193,471 S * 8/1962 Baker 52/73
3,242,620 A * 3/1966 Kaiser E04H 6/025
52/169.1
D215,145 S * 9/1969 Kliewer D25/22
D215,146 S * 9/1969 Kliewer D25/22
D225,051 S * 11/1972 Smithhart D25/56
3,854,254 A * 12/1974 Janosko E04H 15/58
52/63

DESCRIPTION

FIG. 1 is a front perspective view of a carport showing my design;
FIG. 2 is a rear view thereof;
FIG. 3 is a front view thereof;
FIG. 4 is a first side view thereof;
FIG. 5 is a second side view thereof;
FIG. 6 is a top view thereof; and,
FIG. 7 is a bottom view thereof.

1 Claim, 5 Drawing Sheets

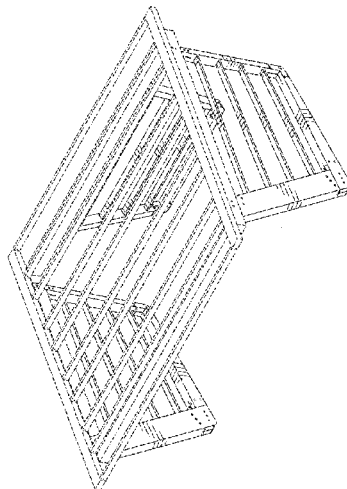

(56)

References Cited

U.S. PATENT DOCUMENTS

2012/0304552 A1* 12/2012 Cox E04B 1/3416
52/73
2015/0218822 A1* 8/2015 Blazley E04D 3/30
52/173.3

OTHER PUBLICATIONS

MacKenzie, Angus. "BMW Gives The 18 Its Very Own Solar Carport." New Atlas (fka Gizmag), Automotive, May 8, 2014. Web. Aug. 30, 2016.

"BMW i, Malibu (Solar Carport Demo)." World Team Now, May 7, 2014. Web. Aug. 30, 2016.

Atiyeh, Clifford. "Have BMW, Will Park Under Bamboo: BMW Creates Fancy Charging Carport for I Models." Car Driver, May 12, 2014. Web. Aug. 30, 2016.

Ingram, Antony. "BMW Designs Custom Solar Charging Station for i3, i8." Yahoo! News, May 8, 2014. Web. Aug. 30, 2016.

Cooper, Daniel. "BMW's Designed An Eco-Friendly Carport for Its Electric Vehicles." Engadget, May 8, 2014. Web. Aug. 30, 2016.

Hard, Andrew. "BMW's Solar Charging Carport is Elegantly Practical." Digital Trends, May 10, 2014. Web. Aug. 30, 2016.

Montalbano, Elizabeth. "BMW Unveils Solar-Energy Harvesting Carport." DesignNews, May 21, 2014. Web. Aug. 30, 2016.

Bruce, Chris. "BMW I creates high-design solar charging carport." Autoblog, May 9, 2014. Web. Aug. 30, 2016.

* cited by examiner

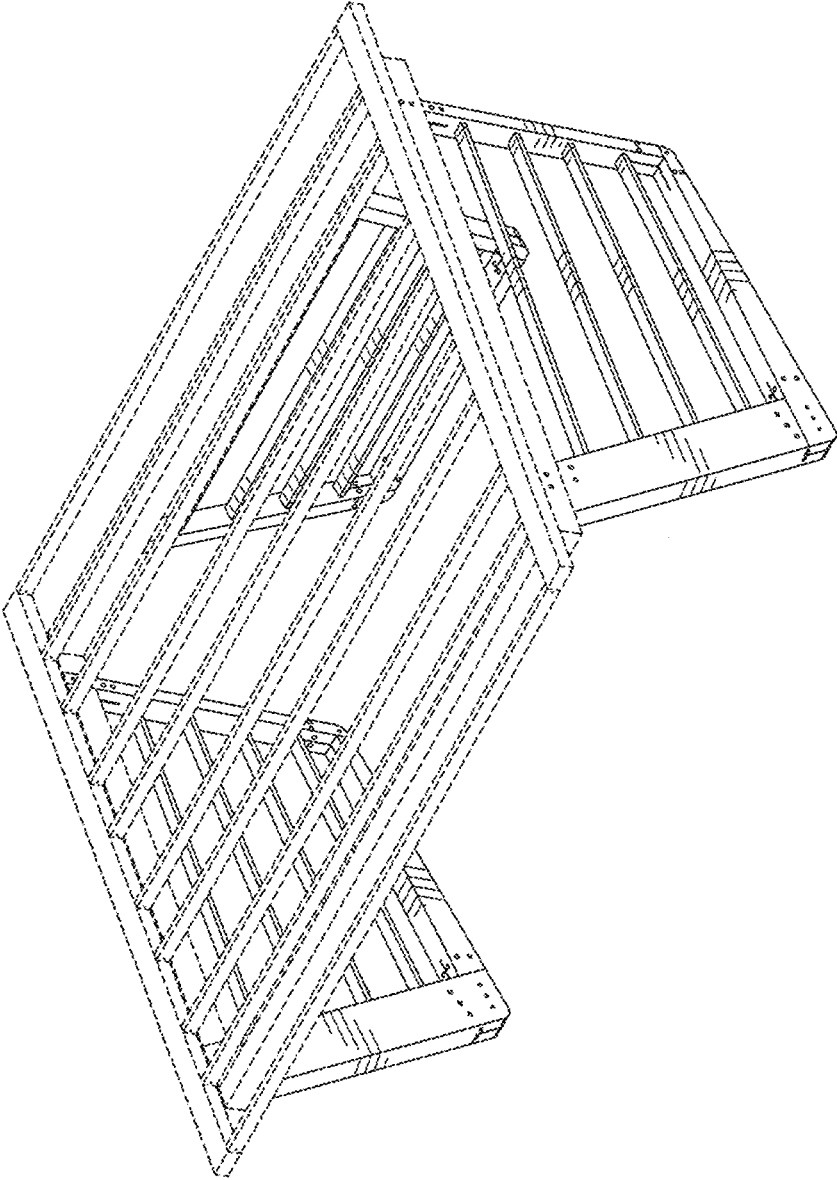

FIG. 1

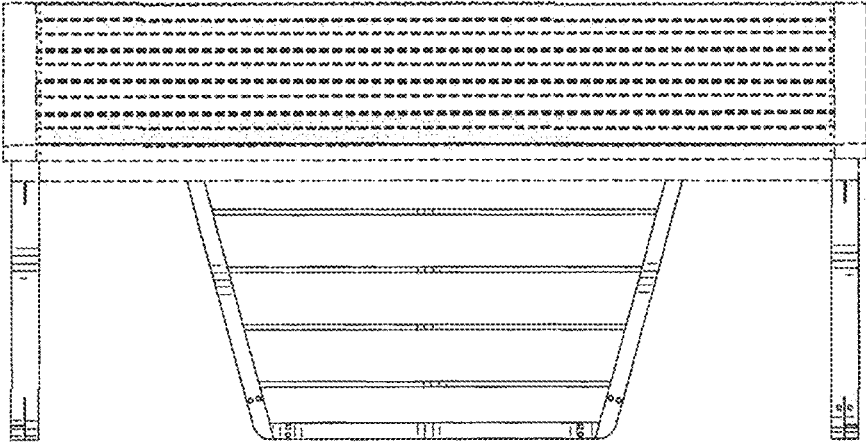

FIG. 2

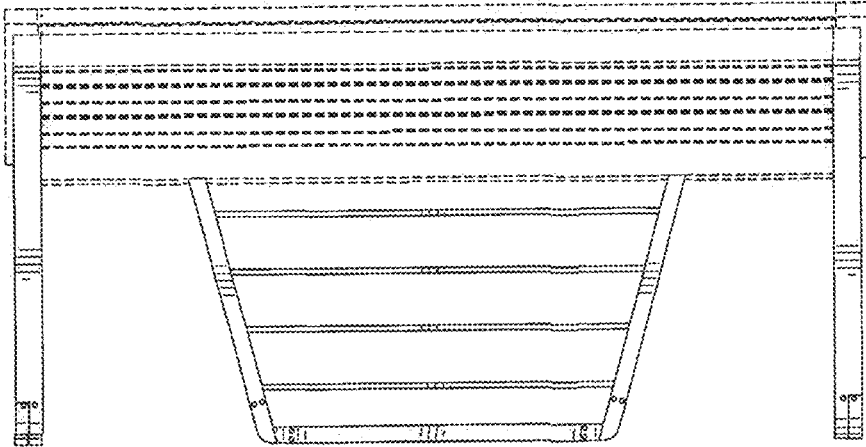

FIG. 3

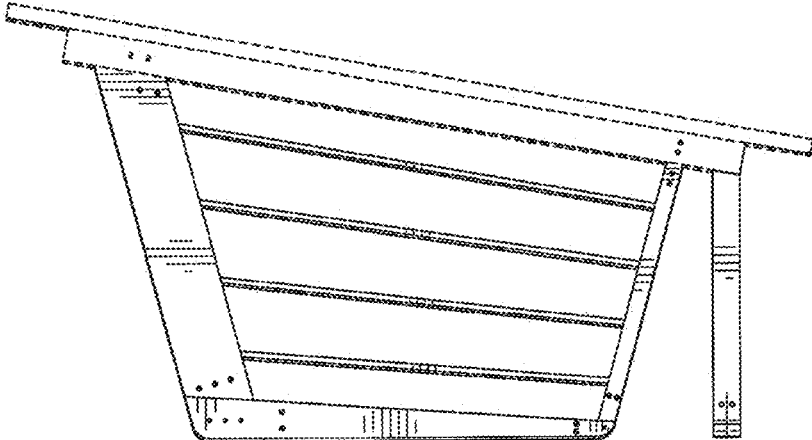

FIG. 4

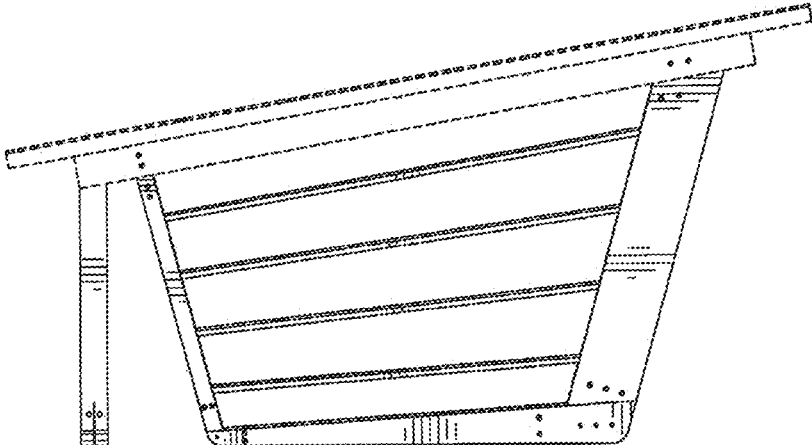

FIG. 5

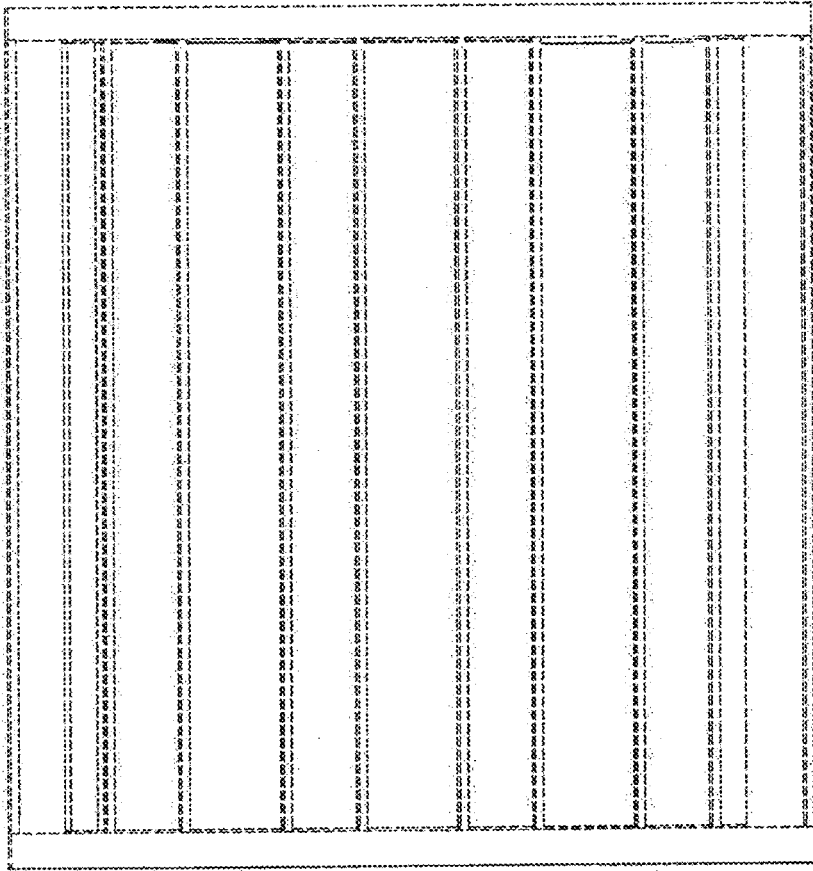

FIG. 6

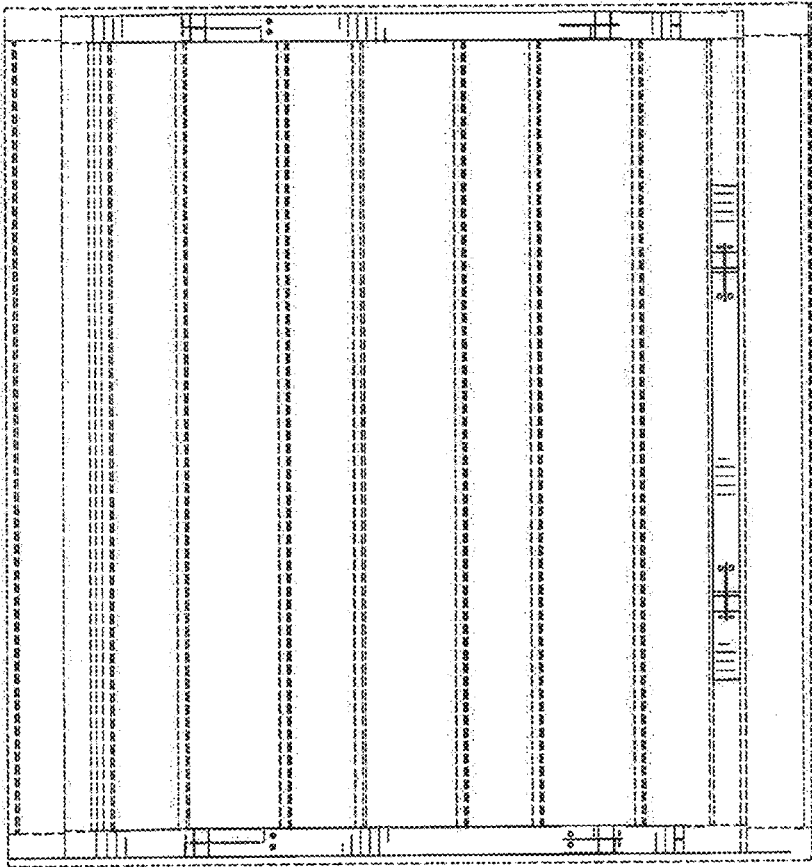

FIG. 7