

(19) World Intellectual Property
Organization
International Bureau



(43) International Publication Date
19 February 2004 (19.02.2004)

PCT

(10) International Publication Number
WO 2004/015247 A1

- (51) International Patent Classification⁷: **F01L 13/08** **John, H.**; 7728 W. Plainfield Avenue, Greenfield, WI 53220 (US).
- (21) International Application Number: PCT/US2003/023711
- (22) International Filing Date: 30 July 2003 (30.07.2003) (74) Agent: **LASKA, Casimir, F.**; Michael Best & Friedrich LLP, 100 East Wisconsin Avenue, Suite 3300, Milwaukee, WI 53202-4108 (US).
- (25) Filing Language: English (81) Designated States (*national*): AU, CN, PL.
- (26) Publication Language: English (84) Designated States (*regional*): European patent (AT, BE, BG, CH, CY, CZ, DE, DK, EE, ES, FI, FR, GB, GR, HU, IE, IT, LU, MC, NL, PT, RO, SE, SI, SK, TR).
- (30) Priority Data: 10/216,523 9 August 2002 (09.08.2002) US
- (71) Applicant: **BRIGGS & STRATTON CORPORATION** [US/US]; 12301 West Wirth Street, Wauwatosa, WI 53222 (US) **Published:**
— with international search report
- (72) Inventors: **GRACYALNY, Gary, J.**; 5625 West Brown Deer Road, Milwaukee, WI 53223 (US). **THIERMANN,**
- For two-letter codes and other abbreviations, refer to the "Guidance Notes on Codes and Abbreviations" appearing at the beginning of each regular issue of the PCT Gazette.*

(54) Title: RETAINER FOR RELEASE MEMBER

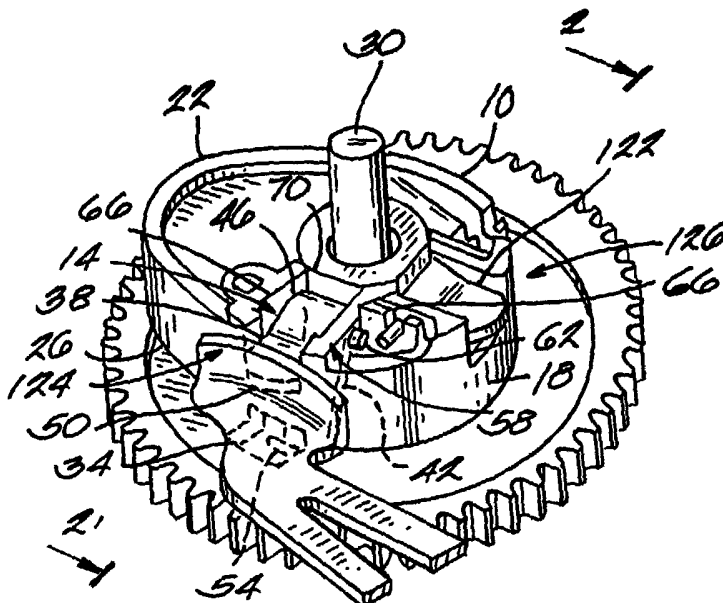

(57) Abstract: A retainer retains a release member for engine valves of an internal combustion engine. The release member causes an engine valve to be actuated depending on various operating conditions of the engine, such as engine speed or oil level. The retainer retains the release member to at least one of a cam lobe and a cam gear. The release member may be substantially L-shaped and centrifugally responsive. Alternatively, the release member may be a substantially U-shaped yoke that at least partially surrounds a cam shaft. The retainer includes a pin that is substantially transverse and non-intersecting to the cam shaft. The pin may be substantially straight and interconnect to bosses that project from the cam gear. Alternatively, the pin may be substantially C-shaped and extend into apertures in the cam gear that extend in the axial direction of the cam gear.

WO 2004/015247 A1

Retainer For Release Member

This application is a continuation-in-part of U.S. Patent Application No. 09/782,468 filed February 9, 2001, which claims priority to U.S. Patent Application No. 09/507,070 filed February 18, 2000, and this application is also a continuation-in-part of U.S. Patent Application No. 10/096,456 filed March 11, 2002, the entire contents of which are incorporated herein by reference.

FIELD OF THE INVENTION

This invention relates to internal combustion engines, and more particularly to release mechanisms for engine valves of internal combustion engines.

BACKGROUND OF THE INVENTION

In a normal four stroke pull-start engine, a starting event moves the engine through one or more engine cycles to start the engine. The starting event may involve a person pulling a pull cord, or an electric starter, rotating the engine. The engine cycle has four strokes: the intake stroke, the compression stroke, the expansion stroke, and the exhaust stroke.

During normal engine operation, an air/fuel mixture is ignited just before the expansion stroke to power the engine and move the engine through the engine cycle. During pull starting, the operator must exert enough force to overcome the resistive force of the compressed air in the combustion chamber during the combustion stroke. The additional force required to compress the air increases the torque on the cord and makes the engine more difficult to start.

A compression release mechanism may be used to release pressure in the combustion chamber during the compression stroke, which reduces the torque and resistive force on the cord. The reduced torque makes the engine easier to start because the operator does not have to exert as large of a force on the pull cord to move the engine through the cycle. Typically, a compression release mechanism slightly unseats an engine valve to vent the combustion chamber during the compression stroke while the engine is rotating at starting speeds. The compression release mechanism generally disengages at or before the engine reaches normal operating speeds.

The object of the compression release mechanism is to reduce the torque on the cord by releasing the pressure in the combustion chamber during the compression stroke.

Since the combustion chamber is relatively airtight when the engine valves are closed, the release of pressure during the compression stroke creates a partial vacuum in the combustion chamber for the expansion stroke. When starting an engine having a compression release mechanism, the operator must exert enough force on the pull cord during the expansion stroke to pull the piston against the partial vacuum in the combustion chamber. The additional force required to overcome the partial vacuum during the expansion stroke creates a torque and the resistive force on the cord, and makes the engine more difficult to start.

In some prior art engines, the compression release mechanism may be pivotally retained to the cam shaft with a pin. An aperture extends through the cam shaft, and the pin extends through the aperture. The pin is connected to the compression release member, and retains the compression release member to the cam shaft. The compression release member may pivot about a pivot axis which extends through the pin. Both the pin, and the pivot axis of the some prior art compression release members intersect with the cam shaft.

Creating an aperture through a cam shaft is generally a difficult machining operation. The cam shaft is generally made from a relatively hard and strong material that may be difficult to machine. A harder material is generally more difficult to machine than a softer material. Additionally, the cam shaft is generally round and cylindrical, and machining into a round surface to create an aperture may also be difficult. The round surface tends to deflect a drill tip, and increase the difficulty of maintaining the center line of a drilled hole through the cam shaft. Machining an aperture into a round surface of a hard material creates many manufacturing problems, such as scrapped parts and excessive tool wear.

25

SUMMARY OF THE INVENTION

A retainer retains a release member for an internal combustion engine. The retainer comprises a cam shaft, and a cam assembly including a cam driving member. The cam driving member may be a cam gear, a pulley, or other means. A pin retains the release member to the cam lobe or the cam driving member. The pin is substantially transverse to the cam shaft, and does not intersect the cam shaft. Preferably, the release member is centrifugally responsive, and pivots about the pin. The release member may be a compression release member, a vacuum release member, or a similar release member that at least partially vents an engine combustion chamber.

As mentioned above, machining an aperture through the cam shaft may present several manufacturing problems, due to the hardness and rounded surface of the cam shaft. In the preferred embodiment, since the pin does not intersect the cam shaft, the retainer does not require any additional machining of the cam shaft. Therefore, many of the problems associated with machining the cam shaft may be avoided. The release member
5 retainer of the preferred embodiment may be manufactured more efficiently than some prior art release members.

In a first embodiment, the release member is preferably L-shaped, and is pivotally retained to the cam lobe. A pin extends through the release member, and is interconnected
10 to the cam lobe. The release member may pivot about the pin. The pin does not intersect the cam shaft. In the first embodiment, the release member may include a separate compression release member and vacuum release member. Each release member may have a separate pin, however, neither pin intersects the cam shaft. Alternatively, nubs may be used to retain the release members to the cam lobe. The release members may pivot
15 about the nubs, but the pivot axis of the release members will not intersect the cam shaft.

In another embodiment, the release member is preferably a U-shaped yoke and at least partially surrounds the cam shaft. A pin extends through the yoke and pivotally retains the yoke to the cam gear. Bosses project from the cam gear, and the pin extends
20 into apertures within the bosses. The yoke may pivot about the pin, and the pin does not intersect the cam shaft. Preferably, the pin is substantially transverse to the cam shaft.

In yet another embodiment, the release member is preferably a U-shaped yoke and includes a first end, a second end, and two legs extending between the first and second end. The yoke at least partially surrounds the cam shaft. Each leg preferably includes a U-shaped recess. A pin extends through the U-shaped recesses, and pivotally retains the
25 yoke to the cam gear. The pin extends through the recesses and into apertures in the cam gear. Preferably, the pin is substantially C-shaped, and the apertures extend in the axial direction of the cam gear. The yoke may pivot about the pin, and the pin does not intersect the cam shaft. The pin is preferably substantially transverse to the cam shaft.

In one embodiment, the pin is substantially C-shaped and includes an elongated
30 middle portion and at least one end portion. The end portion extends into an aperture in the cam gear, and may include barbs that engage the cam gear to interconnect the pin to the cam gear. Alternatively, the end portion may extend through the aperture, and a nut may engage the end portion on the opposite side of the cam gear to retain the end portion within the aperture. Alternatively, the end portion may include clips having barbs at the

end of a flexible extension. The barbs may bend inwardly to permit the end portion to be inserted through the aperture. Once the barbs are through the aperture, the barbs bend back outwardly to engage the cam gear and retain the end portion within the aperture.

In another embodiment, the cam gear may include mounts that project from the cam gear and retain a substantially straight pin. The pin is substantially transverse and non-intersecting to the cam shaft. The mounts may include two bendable tabs that clamp the pin to the mount, and a stop that retains the pin in the axial direction.

Alternatively, the retainer and release member may be interconnected to the cam assembly at a location remote from the cam driving member.

10

BRIEF DESCRIPTION OF THE DRAWINGS

Fig. 1 is a perspective view of a cam and cam follower with a vacuum release member in an engaged position.

Fig. 2 is a cross-sectional view, taken along line 2-2 of Fig. 1.

15

Fig. 3 is a perspective view of a cam and cam follower with a vacuum release member in a disengaged position.

Fig. 4 is a cross-sectional view, taken along line 4-4 of Fig. 1.

Fig. 5 is a plan view of the cam of Fig. 1.

Fig. 6 is a plan view of the cam of Fig. 3.

20

Fig. 7 is a cut-away view of an engine cylinder and piston.

Fig. 8 is a plan view of a second embodiment of a cam and cam follower with a vacuum release member in an engaged position, and a partial cross-sectional view of an engine valve train.

Fig. 9 is a plan view of the vacuum release member of Fig. 8.

25

Fig. 10 is a plan view of a second embodiment of a cam and cam follower with a vacuum release member in a disengaged position, and a partial cross-sectional view of an engine valve train.

Fig. 11 is a plan view of the vacuum release member of Fig. 8.

Fig. 12 is a plan view of the vacuum release member of Fig. 10.

30

Fig. 13 is a plan view of the vacuum release member of Fig. 10.

Fig. 14 is a cross-sectional view, taken along line 14-14 of Fig. 9.

Fig. 15 is a perspective view of a third embodiment of a cam, cam follower, and a vacuum release member.

Fig. 16 is a plan view of the vacuum release member of Fig. 15.

Fig. 17 is a cross-sectional view, taken along line 17-17 of Fig. 16.

Fig. 18 is a graph depicting engine crank degrees in relation to engine valve lift, resistive force, and combustion chamber pressure.

5 Fig. 19 is a perspective view of a fourth embodiment of a cam, cam follower, and a vacuum release member.

Fig. 20 is a plan view of the vacuum release member of Fig. 19.

Fig. 21 is a cross-sectional view, taken along line 21-21 of Fig. 20.

Fig. 22 is a perspective view of a retainer retaining a release member to a cam gear.

Fig. 23 is a perspective view of the retainer of Fig. 22.

10 Fig. 24 is a partial cross-sectional view of the retainer of Fig. 22.

Fig. 25 is a perspective view of a retainer retaining a release member to a cam gear.

Fig. 26 is a perspective view of the retainer of Fig. 25

Fig. 27 is a plan view of the retainer, release member, and cam gear of Fig. 25.

Fig. 28 is a cross-sectional view, taken along line 28-28 of Fig. 27.

15 Fig. 29 is a cross-sectional view, taken along line 29-29 of Fig. 27, illustrating the release member in an engaged position.

Fig. 30 is a cross-sectional view, taken along line 29-29 of Fig. 27, illustrating the release member in a disengaged position.

Fig. 31 is a perspective view of a retainer retaining a release member to a cam gear.

20 Fig. 32 is a partial cross-sectional view of the retainer, release member, and cam gear of Fig. 31.

Fig. 33 is a cross-sectional view, taken along line 33-33 of Fig. 32.

25 Before the embodiments of the invention are explained in detail, it is to be understood that the invention is not limited in its application to the details of construction and the arrangements of components set forth in the following description or illustrated in the drawings. The invention is capable of other embodiments and of being practiced or of being carried out in various ways. Also, it is to be understood that the phraseology and terminology used herein is for the purpose of description and should not be regarded as
30 limiting.

DETAILED DESCRIPTION

Several embodiments of a release member and a retainer are illustrated in the figures. Figs. 1-7 illustrate a first embodiment of a release member. Figs. 8-14 illustrate a second embodiment of a release member. Figs. 15-17 illustrate a third embodiment of a release member. Figs. 19-21 illustrate a fourth embodiment of a release member.

In the first embodiment, as illustrated in Figs. 1-7, a cam 10 has a centrifugally-responsive vacuum release member 14. The vacuum release member 14 is pivotable between an engaged position, as shown in Figs. 1, 2 and 5, and a disengaged position, as shown in Figs. 3, 4 and 6. The cam 10 illustrated in Figs. 1-6 may be used with an engine 16 (Fig. 7) utilizing a direct lever overhead valve system, as disclosed in US Patent Application Serial No. 09/507,070 filed February 18, 2000, which is incorporated herein by reference. The cam 10 has a base radius 18, a cam lobe 22, and a side face 26, and rotates about a cam shaft 30. In the illustrated embodiment, it is not necessary for the cam shaft 30 to rotate, or for the cam 10 to be fastened to the cam shaft 30. The cam shaft 30 may remain stationary while the cam 10 rotates about the cam shaft 30. A cam follower 34 is spring biased to contact the side face 26 of the cam 10 as the cam 10 rotates. The cam follower 34 does not rotate with the cam 10 in relation to the cam shaft 30. The cam lobe 22 extends further from the cam shaft 30 than the base radius 18.

The vacuum release member 14 is centrifugally responsive, and is pivotably retained to the cam 10 to pivot between an engaged position (shown in Figs. 1, 2 and 5) and a disengaged position (shown in Figs. 3, 4 and 6). As shown in Figs. 1, 2 and 5, the vacuum release member 14 is in the engaged position, and extends beyond the base radius 18 to separate the cam follower 34 from the cam 10.

The vacuum release member 14 is substantially L-shaped, and has an engaging portion 38 and a flyweight portion 42 that each extend outward from a bridging portion 46. The bridging portion 46 is substantially U-shaped, and interconnects the engaging portion 38 and the flyweight portion 42. The engaging portion 38 is a relatively flat segment having a cam surface 50 disposed at an end of the engaging portion 38 opposite the bridging portion 46. The cam surface 50 extends beyond the cam 10 and engages the cam follower 34 when the vacuum release member 14 is in the engaged position. As shown in the illustrated embodiment, the cam surface 50 and the cam follower 34 are both arc-shaped to provide a smooth transition for the cam follower 34 between the cam 10 and the cam surface 50. The smooth curved surfaces of the cam follower 34 and cam surface 50 reduce the wear and extend the life of the parts.

The flyweight portion 42 extends from the end of the bridging portion 46 opposite the engaging portion 38, and has a mass sufficient to pivot the vacuum release member 14 in response to engine speed. As illustrated in Figs. 2 and 4, the flyweight portion 42 is larger than the engaging portion 38. However, the size of the portions 38, 42 may be varied depending on the desired kick-out speed of the vacuum release member 14, as discussed below. A curved end 54 is disposed at the end of the flyweight portion 42 opposite the bridging portion 46, and bends to face back toward the bridging portion 46. The curved end 54 concentrates mass near the end of the flyweight portion 42, and shifts the center of gravity of the vacuum release member 14 toward the flyweight portion 42. The increased mass and shifted center of gravity lowers the kick-out speed and causes the vacuum release member 14 to pivot to the disengaged position at a lower engine speed than if the flyweight portion 42 was the same size as the engaging portion 38.

The size and mass of the flyweight portion 42 may be modified to achieve a desired center of gravity and alter the kick-out speed, causing the vacuum release member 14 to pivot to the disengaged position at a desired speed. The vacuum release member 14 is preferably made from stamped metal and is bent into a desired shape, or is cut and bent from a metal roll. The stamping and bending process for manufacturing the vacuum release member 14 is relatively inexpensive. Bending the curved end 54 provides sufficient clearance for the flyweight portion 42 and concentrates the mass near the curved end 54 to shift the center of gravity. Alternatively, the vacuum release member 14 can be made from powdered metal, die casting, or another metal forming process, and the thickness or composition of the vacuum release member 14 can be modified to obtain a desired center of gravity. The flyweight portion 42 can also be made from a material having a higher density than the engaging portion 38. In a multi-density embodiment, the flyweight portion 42 and engaging portion 38 may be similar in size, but because of the higher density material, the flyweight portion 42 can still have a greater mass than the engaging portion 38.

In the illustrated embodiments, the cam 10 has a slot 58 that is partially formed in the base radius 18, and extends radially inward toward the cam shaft 30. The vacuum release member 14 is disposed within the slot 58, and is pivotally retained by a pivot pin 62. The pivot pin 62 is partially disposed within the curved bridging portion 46, and the vacuum release member 14 is free to pivot about the pivot pin 62. The slot 58 has two side walls 66 and a back surface 70. The pivot pin 62 preferably extends between the side

walls 66. The pivot pin 62 is substantially transverse and non-intersecting to the cam shaft 30.

In an alternate embodiment, the vacuum release member 14 can be pivotally retained within the slot 58 with nubs. The nubs project inward into the slot 58 from side walls of the slot 58, and the vacuum release member 14 may pivot about the nubs. The pivot axis of the vacuum release member 14 passes through the nubs, and is substantially transverse and non-intersecting to the cam shaft 30.

A shoulder 74 is disposed near the intersection of the slot 58 and the base radius 18. When the vacuum release member 14 is in the engaged position, as shown in Fig. 2, the engaging portion 38 contacts the shoulder 74, and the shoulder 74 provides support for the vacuum release member 14. In a vertical shaft engine, gravity biases the vacuum release member 14 toward the engaged position and a return spring is not necessary. A return spring may be needed in a non-vertical shaft engine embodiment to bias the vacuum release member 14 toward the engaged position.

As mentioned above, the cam follower 34 is spring biased to contact the cam 10. When the vacuum release member 14 separates the cam follower 34 from the cam 10, the spring biased cam follower 34 exerts a force on the vacuum release member 14. Most of the force exerted on the vacuum release member 14 by the cam follower 34 is transferred to the back surface 70, and is not absorbed by the pivot pin 62. The bridging portion 46 contacts the back surface 70, which buttresses the vacuum release member 14 and absorbs most of the force the cam follower 34 applies on the vacuum release member 14. This embodiment preferably does not apply large shear stresses on the pivot pin 62, and may extend the life of the pivot pin 62.

The cam 10 and vacuum release member 14 rotate about the cam shaft 30, and the cam follower 34 contacts the cam 10 as the cam 10 rotates. As shown in Fig. 7, the cam follower 34 is interconnected to an engine valve, although they could be separate components. The term "engine valve" may refer to an exhaust valve 82, an intake valve 86, or both. The vacuum release member 14 preferably affects movement of the exhaust valve 82, but the vacuum release member 14 can alternatively be used to affect the movement of the intake valve 86. The greater the distance the cam follower 34 moves away from the cam shaft 30, the more the cam follower 34 opens the respective engine valve 82 or 86. The cam follower 34 is moved a greater distance from the cam shaft 30 when the cam follower 34 contacts the cam lobe 22, than when the cam follower 34 contacts the base radius 18. In the normal engine cycle, as described below, the cam lobe

22 is timed to contact the cam follower 34 and unseat the exhaust valve 82 during the engine exhaust stroke.

Similarly, as shown in Figs. 5-6, the cam follower 34 is also moved a greater distance from the cam shaft 30 when the cam follower 34 contacts the cam lobe 22, than
5 when the cam follower 34 contacts the vacuum release member 14. The distance the cam surface 50 extends beyond the base radius 18 determines how far the vacuum release member 14 separates the cam follower 34 from the cam 10, and how far the cam follower 34 opens the respective engine valve 82 or 86 (Fig. 7).

The vacuum release member 14 generally displaces the cam follower 34 a greater
10 distance than the base radius 18 displaces the cam follower 34. In embodiments incorporated into other engines, the cam follower may move toward the cam shaft to open the valve, instead of away. In these embodiments, the cam follower will move closer to the cam shaft when the cam follower contacts the vacuum release member, than when the cam follower contacts the base radius. The cam lobe will displace the cam follower and
15 the valve a greater distance than the vacuum release member.

As shown in Figs. 5 and 6, the width of the engaging portion 38 determines the amount of time the vacuum release member 14 separates the cam follower 34 from the cam 10. The wider the engaging portion 38 and the cam surface 50, the longer period of time the vacuum release member 14 contacts the cam follower 34 and separates the cam
20 follower 34 from the cam 10. In an alternate embodiment, the engaging portion 38 may have an extension 88 that extends the cam surface 50 in a direction substantially tangential to the cam 10. In Figs. 5-6, the extension 88 is illustrated in broken lines to show the alternate embodiment. A vacuum release member 14 having the extension 88 would separate the cam follower 34 from the cam 10 for a longer period of time than a vacuum
25 release member 14 without an extension 88, which would thereby open the respective engine valve 82 or 86 (Fig. 7) for a longer period of time. Additional clearance from the slot 58 may be needed to permit the vacuum release member 14 with the extension 88 to pivot between the engaged and disengaged positions.

As shown in Fig. 7, the engine 16 has a reciprocable piston 90 disposed within a
30 cylinder 94 and a crankcase 98. A crankshaft 102 is also disposed within the crankcase 98. Engine valves 82, 86 are disposed near an end of the cylinder 94, and a combustion chamber 106 is disposed between the piston 90 and the engine valves 82, 86. The vacuum release member 14 (Fig. 5) is timed to contact the cam follower 34 and unseat the exhaust valve 82 during the expansion stroke when the piston 90 is moving away from the

combustion chamber 106 and toward the crankcase 98. The vacuum release member 14 (Fig. 5) opens the exhaust valve 82 less during the expansion stroke than the cam lobe 22 opens the exhaust valve 82 during the exhaust stroke.

Fig. 18 illustrates a graph representing the engine valve lift, cylinder pressure, and pull force in relation to the crank degrees of the engine cycle. Figs. 7 and 18 together illustrate various conditions occurring within the engine 16 during the engine cycle. Engine cycle crank degrees is represented as 720 degrees because the crankshaft 102 completely rotates twice for each engine cycle. 0 degrees to 180 degrees represents the expansion stroke during which the piston 90 is moving away from the combustion chamber 106 and toward the crankcase 98. 180 degrees to 360 degrees represents the exhaust stroke during which the piston 90 is moving away from the crankcase 98 and toward the combustion chamber 106. 360 degrees to 540 degrees represents the intake stroke during which the piston 90 is moving away from the combustion chamber 106 and toward the crankcase 98. 540 degrees to 720 degrees represents the compression stroke during which the piston 90 is moving away from the crankcase 98 and toward the combustion chamber 106.

The valve lift represents the distance in inches that the exhaust valve 82 or the intake valve 86 is moved from each valve's respective seat. The term "lift" should not be construed to mean vertical movement. "Lift" merely refers to the movement of the engine valves, and the movement may be in any direction depending on the orientation of the engine and valves. A lift of 0 represents a closed, or seated, position. As illustrated in Fig. 18, exhaust valve lift 110 illustrates the distance the exhaust valve 82 is moved from its seat while the vacuum release member 14 and compression release member 122 are in the engaged position. The intake valve lift 114 illustrates the distance the intake valve 86 is moved from its seat. The valve lifts 110, 114 graphed in Fig. 18 represent the approximate valve lift for the illustrated embodiment of a 5 hp engine of the direct lever type. The actual valve lift for an engine will greatly depend upon the size and configuration of the engine. Additionally, the engine valves 82, 86 must overcome valve lash when opening, and do not actually open to permit air flow until the valve lift exceeds approximately 0.01 inches.

The exhaust valve 82 is lifted when the cam follower 34 contacts the vacuum release member 14, the cam lobe 22 and the compression release member 122 at various points during the engine cycle. The exhaust valve lift 110 illustrates the distance the exhaust valve 82 is lifted from its seat while the vacuum release member 14 and

compression release member 122 are in the engaged position. In Fig. 18, a portion 110a of the exhaust valve lift 110 represents the lift due to the vacuum release member 14. A portion 110b of the exhaust valve lift 110 represents the lift due to the cam lobe 22. A portion 110c represents the lift due to the compression release member 122.

5 As shown in Figs. 7 and 18, the cam lobe 22 contacts the cam follower 34 to lift the exhaust valve 82 approximately 0.21 inches at portion 110b during the exhaust stroke. Comparatively, the vacuum release member 14 (Fig. 5) contacts the cam follower 34 to lift the exhaust valve 82 approximately 0.04 inches at portion 110a during the expansion stroke. As mentioned above, the vacuum release member 14 is normally used in
10 cooperation with a compression release member 122 to reduce the resistive torque during starting. Starting usually involves the operator pulling on a pull cord to rotate the engine through the engine cycle, but starting could also include an electric starter rotating the engine.

A compression release member 122 illustrated in Figs. 1-6 is disclosed in US
15 Patent Application Serial No. 09/782,468 filed February 9, 2001, which is incorporated herein by reference. A mechanical vacuum release ("MVR") 124 refers to the entire mechanism that relieves the vacuum created in the combustion chamber 106 during a non-combusting expansion stroke. The MVR 124 comprises the vacuum release member 14, the cam follower 34, and the exhaust valve 82. A mechanical compression release
20 ("MCR") 126 refers to the entire mechanism that relieves the pressure in the combustion chamber 106 during a compression stroke. The MCR 126 comprises the compression release member 122, the cam follower 34, and the exhaust valve 82.

The compression release member 122 contacts the cam follower 34 to lift the exhaust valve 82 during the compression stroke to relieve pressure in the combustion
25 chamber 106 by allowing air to exit the combustion chamber 106 through the exhaust valve 82. The combustion chamber 106 is substantially airtight when the engine valves 82, 86 are closed. Therefore, releasing air from the combustion chamber 106 during the compression stroke creates a vacuum in the combustion chamber 106 during the expansion stroke. The primary reason the vacuum condition exists is because the pressure within the
30 combustion chamber 106 was released by the compression release member 122. The vacuum release member 14 contacts the cam follower 34 to lift, or unseat, the exhaust valve 82 during the expansion stroke to relieve the vacuum in the combustion chamber 106 by allowing air to enter the combustion chamber 106 through the exhaust valve 82.

As illustrated by the exhaust valve lift 110 in Fig. 7 and 18, the vacuum release member 14 preferably first contacts the cam follower 34 to lift the exhaust valve 82 at approximately 40 crank degrees. The vacuum release member 14 could possibly begin to open the exhaust valve 82 between 0 and 90 crank degrees, and the preferred range for beginning to open the exhaust valve 82 is between 30 and 70 crank degrees. The expansion stroke occurs between 0-180 crank degrees, but a large portion of the work from the expansion stroke is done between 0-120 crank degrees. Therefore, the engine 16 may lose too much power and may not properly accelerate if the vacuum release member 14 begins to open the exhaust valve 82 too early.

The vacuum release member 14 contacts the cam follower 34 and the exhaust valve 82 is preferably opened approximately 0.04 inches at about 100 crank degrees, as shown by portion 110a, during the expansion stroke. The exhaust valve 82 begins to close before the cam lobe 22 contacts the cam follower 34 to open the exhaust valve 82 for the exhaust stroke. The exhaust valve 82 is opened approximately 0.21 inches at about 255 crank degrees, as shown by portion 110b, and the exhaust valve 82 then returns to a closed position for the intake stroke at approximately 450 crank degrees. The compression release mechanism 122 first contacts the cam follower 34 to open the exhaust valve 82 during the compression stroke at approximately 550 crank degrees. The exhaust valve 82 is opened approximately 0.04 inches at about 610 crank degrees, as shown by portion 110c, and the exhaust valve 82 then returns to a closed position at approximately 670 crank degrees.

Once the compression stroke ends at 720 degrees, the expansion stroke begins again at 0 degrees. In Fig. 18, 720 degrees and 0 degrees refer to the same point, which may also be referred to as top-dead-center, since it represents the point where the piston 90 is at the end of its stroke near the engine valves 82, 86. At 720 or 0 degrees, or top-dead-center, the piston 90 changes directions, and the compression stroke transitions into the expansion stroke.

As mentioned above, the MCR 126 preferably opens, as shown by exhaust valve lift 110, at approximately 550 degrees, and closes at approximately 670 degrees. Also, the MVR 124 preferably opens at approximately 40 degrees, and begins to close near 135 degrees. The points where the MCR 126 closes and MVR 124 opens are more significant than where the MCR 126 opens and the MVR 124 closes. In the illustrated embodiment, the MCR 126 closes near 670 degrees, and the MVR 124 opens near 40. Therefore, the

exhaust valve 82 is closed for approximately 90 crank degrees between the MCR 126 and the MVR 124, and the exhaust valve 82 is closed at top-dead-center.

As mentioned above, if the MVR 124 opens too early, the engine 16 may lose too much power and may not properly accelerate. Similarly, the engine 16 may not be able to accelerate if the MCR 126 closes too late. Even when the MVR 124 and MCR 126 are
5 engaged, the engine 16 must retain and begin to compress some of the air/fuel mixture for combustion to accelerate the engine speed. Therefore, the exhaust valve 82 must remain substantially closed when the engine is at 720 degrees, or top-dead-center, so that the engine 16 can eventually accelerate to normal operating speeds, which will disengage the
10 MVR 124 and MCR 126, as described below.

In the illustrated embodiment, the exhaust valve 82 is closed for approximately 90 crank degrees, which includes 720 degrees, or top-dead-center. The exhaust valve 82 must be closed at 720 degrees, and the engine could possibly operate as long as the MCR 126 closes far enough before 720 degrees, and the MVR 124 opens far enough after 720
15 degrees to permit some combustion and work transfer to the crankshaft 102 to occur. Preferably, the exhaust valve 82 is closed for at least 40 crank degrees between the MCR 126 and MVR 124, including 720 degrees.

All of the degrees referred to above have been crank degrees representing crankshaft 102 rotation. As mentioned above, crank degrees goes up to 720 degrees
20 because the crankshaft 102 completely rotates twice for every engine cycle. However, the cam shaft 30 only completely rotates once for every engine cycle, so cam degrees representing cam shaft 30 rotation only goes up to 360 cam degrees. Cam degrees are generally one-half of the corresponding crank degrees.

As shown in Fig. 18 and mentioned above, the maximum for the MVR 124 is
25 approximately 100 crank degrees, and the maximum for the MCR 126 is approximately 610 crank degrees. The maximums are separated by approximately 210 crank degrees. Converted from crank degrees into cam degrees, the maximums are separated by approximately 105 cam degrees. The maximums may represent the centerlines of the vacuum release member 14 and the compression release member 122.

As illustrated in Figs. 5 and 6, the centerlines of the vacuum release member 14
30 and the compression release member 122 are spaced approximately 105 cam degrees apart in relation to the cam shaft 30. The specific degree of separation between the centerlines is not necessary, and the centerlines could be modified by either opening the MCR 126 earlier, or closing the MVR 124 later. As mentioned above, the point where the MCR 126

opens and the MVR 124 closes is not as significant as where the MCR 126 closes and MVR 124 opens. Therefore, since the separation of the centerlines may be easily modified by adjusting non-critical features, the separation between the centerlines could be increased above 105 cam degrees. Additionally, the centerlines of the engaging portion 38, cam surface 18 and the cam follower 34 may be offset, and need not be aligned with one another. However, as mentioned above, the exhaust valve 82 must close between the MCR 126 closing and the MVR 124 opening, and the exhaust valve 82 is preferably closed for 40 crank degrees, or 20 cam degrees. Therefore, the vacuum release member 14 and the compression release 122 are preferably spaced far enough apart to allow the cam follower 34 to contact the cam 10, and to allow the exhaust valve 82 to close between the MCR 126 and the MVR 124.

The vacuum release member 14 and the compression release member 122 only contact the cam follower 34 to lift the exhaust valve 82 while the members 14, 122 are in the engaged position. As mentioned above, the vacuum release member 14 is in the engaged position (Figs. 1, 2 and 5) as the engine is started. As the engine speed increases and reaches normal operating speeds, the rotation speed of the cam 10 and vacuum release member 14 about the cam shaft 30 also increases. Once the engine speed reaches a predetermined kick-out speed, the flyweight portion 42 is centrifugally forced away from the cam shaft 30, causing the vacuum release member 14 to pivot about the pivot pin 62 and move into the disengaged position (Figs. 3, 4 and 6). As the vacuum release member 14 pivots into the disengaged position, the engaging portion 38 is moved away from the shoulder 74 and out of contact from the cam follower 34. Once the vacuum release member 14 is disengaged, the cam follower 34 preferably contacts the cam 10 throughout the entire rotation of the cam 10, and the engine valves 82, 86 operate normally.

As mentioned above, the vacuum release member 14 is in the engaged position (Figs. 1, 2 and 5) for engine starting speeds, and pivots to the disengaged position (Figs. 3, 4 and 6) when the engine reaches normal operating speeds. The kick-out speed generally occurs during the transition between starting speeds and normal operating speeds. The purpose of the vacuum release member 14 is to reduce resistance during the starting event, and it is only desirable for the vacuum release member 14 to be engaged during engine starting speeds. A person pulling on a pull cord to start an engine generally rotates the engine approximately 350-700 RPM, with the average usually being between approximately 500-600 RPM. The desired range for the kick-out speed for the vacuum release member 14 is approximately 200-600 RPM. The kick-out speed could be below

200 RPM, but the vacuum release member 14 would not work as effectively. Also, the kick-out speed could be above 600 RPM, but the engine begins to lose too much power if the vacuum release member 14 remains engaged at too high of a speed.

5 Since the vacuum release member 14 is normally used in cooperation with the compression release member 122, the vacuum release member 14 should preferably not remain engaged after the compression release member 122 has disengaged. The kick-out speed for the vacuum release member 14 is preferably less than, or similar to the kick-out speed for the compression release member 122. In the illustrated embodiment, the flyweight portion 42 of the vacuum release member 14 is larger than the corresponding
10 flyweight of the compression release member 122. The relatively large flyweight portion 42 generally causes the vacuum release member 14 of the illustrated embodiment to disengage at a lower speed than the compression release member 122. If the vacuum release member 14 and the compression release member 122 were desired to disengage at approximately the same speed, then the shape of the members 14, 122 could also be
15 approximately the same.

The MVR 124 and the MCR 126 are intended to reduce the resistive engine torque, or resistive force, on the pull cord ("pull force") during starting. Fig. 18 illustrates the pull force in pounds in relation to crank degrees for an engine. A dual release line 128 represents the pull force for an engine having both a MCR 126 and a MVR 124. A single
20 release line 130 represents the pull force for an engine having only a MCR 126, but not a MVR 124. The single release line 130 provides a comparative illustration of the additional pull force for an engine without a MVR 124, and therefore also illustrates the pull force reduced by the MVR 124. The single release line 130 has a peak near 90 degrees that is not present on the dual release line 128, and this peak near 90 degrees represents the pull
25 force reduced by the MVR 124. A shaded area 130a under the single release line 130 represents the energy reduction by using the MVR 124.

As mentioned above, the MVR 124 is only needed when a MCR 126 is used, and the pull force reduced by the MCR 126 is significantly larger than the pull force reduced by the MVR 124. The pull force for an engine without a MCR 126 would be off the scale
30 of Fig. 18.

A pressure line 134 represents the pressure in psi within the combustion chamber 106 during the starting event for an engine having only a MCR 126. When the engine valves 82, 86 are both closed, the combustion chamber 106 has a substantially air-tight seal. The pressure line 134 may fluctuate as the movement of the piston 90 increases or

decreases the volume of the combustion chamber 106, because the change of volume of the substantially sealed combustion chamber 106 will also change the pressure within the combustion chamber 106. For most of the engine cycle illustrated in Fig. 18, the pressure line 134 is near zero, which indicates that one of the engine valves 82, 82 are open and the combustion chamber 106 is vented. The pressure line 134 becomes slightly negative (meaning a vacuum) near 500 crank degrees as the piston 90 moves away from the combustion chamber 106 during the intake stroke to draw the air/fuel mixture into the combustion chamber 106 through the open intake valve 86.

In the illustrated embodiment, the MCR 126 begins closing the exhaust valve 82 at approximately 630 crank degrees, and the exhaust line 110c begins decreasing. At this same time, the piston 90 is moving toward the combustion chamber 106 during the compression stroke to decrease the volume of the combustion chamber 106. The combination of the exhaust valve 82 closing and the volume of the combustion chamber 106 decreasing causes the pressure within the combustion chamber 106 to increase, so the pressure line 134 begins increasing near 630 crank degrees. As the pressure line 134 increases, the pull force required to continue moving the piston 90 toward the combustion chamber 106 also increases, so the dual release line 128 also begins increasing near 630 crank degrees.

The pressure line 134 continues increasing after the exhaust valve 82 closes because the piston 90 continues moving toward the combustion chamber 106 to decrease the volume of the combustion chamber 106 after the combustion chamber 106 is resealed. Once the piston 90 passes top-dead-center at 720 or 0 crank degrees, the pressure built-up within the combustion chamber 106 pushes the piston 90 downward and actually creates a negative force on the pull cord, as shown by the dual release line 128 which decreases below zero immediately after 0 degrees.

As described above, the pressure line 134 represents the pressure for an engine having only a MCR 126. In an engine having only a MCR 126, the pressure line 134 becomes negative (meaning a vacuum) as the piston 90 continues moving away from the combustion chamber 106 and toward the crankcase 106 because a portion of the air within the combustion chamber 106 was released through the exhaust valve 82. The volume of the combustion chamber 106 continues to increase, but there is no new air available to fill this volume so a vacuum is created.

In an engine having both a MCR 126 and a MVR 124, the MVR 124 unseats the exhaust valve 82 during the expansion stroke and air is drawn into the combustion

chamber 106 to minimize the vacuum otherwise created by the MCR 126. The exhaust line 110a begins increasing near 40 crank degrees as the MVR 124 begins opening the exhaust valve 82. A shaded area 134a above the pressure line 134 near 90 crank degrees represents the vacuum created by the MCR 126. The MVR 124 reduces vacuum represented by the shaded area 134a to near zero. Since the vacuum is reduced by the MVR 124, the dual release line 128 also remains near zero at approximately 90 crank degrees. As described above, the single release line 130 increases near 90 crank degrees because additional pull force is needed to overcome the vacuum 134a created by the MCR 126. The MVR 124 reduces the vacuum 134a, and thereby reduces the energy 130a needed to overcome the vacuum.

As mentioned above, Figs. 1-6 illustrate the first embodiment of a release member incorporated into an engine utilizing a direct lever overhead valve system. Figs. 8-14 illustrate a second embodiment of a release member that implements a centrifugally responsive vacuum release mechanism 214 in a different engine configuration. The second embodiment relieves a vacuum within the combustion chamber during the expansion stroke when the engine is rotating at cranking and starting speeds.

In the second embodiment, a cam 218 rotates with a cam shaft 222, and contacts a tappet-type cam follower 226 which controls an engine valve 230. The vacuum release mechanism 214 is disposed near the cam 218, and comprises a blocking member 234 and a cantilevered beam 238. A cam surface 258 on the beam 238 acts as the vacuum release member.

Similar to the first embodiment, the second embodiment also has an engaged position, as shown in Figs. 8, 9 and 11, and a disengaged position, as shown in Figs. 10, 12 and 13. As illustrated in Figs. 8, 9 and 11, the blocking member 234 has a tab 242 that is disposed between the cantilevered beam 238 and the cam shaft 222 when the vacuum release mechanism 214 is in the engaged position. In Fig. 11, the cam 218 has a base radius 246 and a cam lobe 250. The base radius 246 is a portion of the cam 218 that extends a substantially uniform distance from the cam shaft 222. The cam lobe 250 is a bulge that extends outward from the cam shaft 222 beyond the base radius 246. The cam follower 226 is interconnected to the engine valve 230, and contacts the cam 218 as the cam 218 rotates. The cam follower 226 preferably opens the engine valve 230 when the cam lobe 250 contacts the cam follower 226. The engine valve 230 is preferably an exhaust valve 254, but it could possibly be an intake valve. The engine valve 230 is configured to be closed when the cam follower 226 contacts the base radius 246. The cam

lobe 250 is preferably timed to contact the cam follower 226 and open the exhaust valve 230 during the exhaust stroke of the engine.

The cantilevered beam 238 has a cam surface 258 that is disposed near the end of the cantilevered beam 238 adjacent the cam 218. The cantilevered beam 238 is interconnected to a cam gear 262, and has a bracket 266 at the end of the cantilevered beam 238 opposite the cam surface 258. The cam gear 262 rotates the cam in timed relation to the engine crankshaft. When the vacuum release mechanism 214 is in the engaged position (Figs. 8, 9 and 11), the cam surface 258 extends beyond the base radius 246 and separates the cam follower 226 from the cam 218 to open, or unseat, the engine valve 230. The vacuum release mechanism 214 preferably opens the engine valve 230 less during the expansion stroke than the cam lobe 250 opens the engine valve 230 during the exhaust stroke. The vacuum release mechanism 214 is preferably timed to contact the cam follower 226 and open the engine valve 230 during the expansion stroke of the engine.

In the illustrated embodiment, the blocking member 234 is substantially U-shaped, and has respective flyweight portions 270 near the two ends of the U-shape. The blocking member 234 is pivotably coupled to the cam shaft 222, and may pivot between the engaged position (Figs. 8, 9 and 11) and the disengaged position (Figs. 10, 12 and 13). As mentioned above, the vacuum release mechanism 214 is normally used in cooperation with a compression release member 274 to reduce the resistive torque during starting. In the second embodiment, the blocking member 234 may also function as the compression release member 274, similar to the saddle or yoke-type compression release member disclosed in US Patent No. 4,453,507, which is incorporated herein by reference.

A cam member 278 is disposed near the curved portion of the blocking member 234, and extends away from the cam shaft 222 and beyond the base radius 246. The cam member 278 may form a portion of the compression release member 274 and contact the cam follower 278 to separate the cam follower 278 from the cam 218. The cam member 278 is preferably timed to contact the cam follower 226 and open the engine valve 230 during the compression stroke when the blocking member 234 is in the engaged position. A return spring 282 may be used to bias the blocking member 234 toward the engaged position, and the blocking member 234 preferably remains in the engaged position when the engine is rotating at or below starting speeds.

As the engine and cam shaft 222 begin to rotate faster, the blocking member 234 also rotates faster, and the flyweight portions 270 are centrifugally forced away from the cam shaft 222. The centrifugal force on the flyweight portions 270 causes the blocking

member 234 to pivot toward the disengaged position, as shown in Figs. 10, 12 and 13. When the blocking member 234 reaches the disengaged position, as shown in Fig. 13, the tab 242 is no longer disposed between the cantilevered beam 238 and the cam shaft 222.

As illustrated in Fig. 10, a valve spring 286 biases the engine valve 230 toward a closed position. The spring biased engine valve 230 applies a force on the cam follower 226, which in turn applies a force on the cam 218. The cantilevered beam 238 is preferably made from a hardened material, such as metal or a similar material that is relatively flexible yet resilient and durable. When the blocking member 234 is in the disengaged position, the tab 242 is not disposed between the cantilevered beam 238 and the cam shaft 222, and the tab 242 does not support the cantilevered beam 238 against the force of the cam follower 226. The cantilevered beam 238 alone, without the tab 242, can not support the force of the valve spring 286 and cam follower 226. The valve spring 286 and cam follower 226 deflect the cantilevered beam 238 so the cam follower 226 may contact the cam 218. Therefore, once the blocking member 234 pivots to the disengaged position, the engine returns to a relatively normal engine cycle.

In the second embodiment, the blocking member 234 may also function as the compression release member 274. In addition, the blocking member 234 must pivot to the disengaged position before cantilevered beam 238 may deflect to allow the cam follower 226 to contact the cam 218. Therefore, the vacuum release mechanism 214 and the compression release member 274 of the second embodiment have similar kick-out speeds and disengage at approximately the same time. Figs. 10, 12 and 13 illustrate the tab 242 pivoted away from the cantilevered beam 238, and the cantilevered beam 238 deflected to permit the cam follower 226 to contact the cam 218.

The cantilevered beam 238 is interconnected to the cam gear 262 with the bracket 266. Conventional fastening devices, such as screws, bolts, nuts, or rivets, may be used to fasten the bracket to the cam gear 266. The cam gear 266 may be made from a plastic material that may be heat deformed. As shown in Fig. 14, the bracket 266 may be alternatively fastened to the cam gear using plastic nubs 290 that extend from the cam gear 266 and may be melted to hold the bracket 266 in the proper position. In Fig. 14, a pre-melted nub 294 is represented by a dashed line. The pre-melted nub 294 is first placed through a hole 298 in the bracket 266. The nub 290 is exposed to a heat source that melts the nub 290 around the hole 298 to form a plastic integral rivet.

Figs. 15-17 illustrate a third embodiment of a release member. In Figs. 15-17, a centrifugally responsive vacuum release member 314 and a compression release member

318 are both interconnected to a single yoke 322 that is disposed near a cam 326 and a cam shaft 328. The yoke 322 is pivotally coupled to a cam gear 330 to pivot between an engaged position and a disengaged position. Two bosses 334 project from the cam gear 330, and apertures extend into the bosses 334. A pin 338 extends through the bosses 334 and the yoke 322 to retain the yoke 322 to the cam gear 330. In the illustrated embodiment, the pin 338 does not pass through the cam shaft 328. The pin 338 is substantially transverse and non-intersecting to the cam shaft 328.

The yoke 322 is substantially U-shaped, and has a tab portion 342 and two flyweight portions 346. The tab portion 342 is disposed near the curved portion of the U-shaped yoke 322, and the flyweight portions 346 are disposed near the two ends of the yoke 322. The vacuum release member 314 is a tab that projects outward from the tab portion 342, in a direction opposite the cam shaft 328. The compression release member 318 may also be a tab that extends outward from the tab portion 342. The vacuum release member 314 and compression release member 318 both contact a cam follower 350 when the yoke 322 is in the engaged position at engine starting speeds. The vacuum release member 314 contacts the cam follower 350 to open an engine valve during the expansion stroke. In the illustrated embodiment, when the cam follower 350 contacts the vacuum release member 314 and compression release member 318, the tab portion 342 contacts the cam shaft 328, and the cam shaft 328 helps support the force exerted by the cam follower 350.

The flyweight portions 346 have sufficient mass to function as a flyweight. Once the engine reaches normal engine operating speeds, the flyweight portion 346 is centrifugally forced away from the cam shaft 328, causing the yoke 322 to pivot to the disengaged position. As illustrated in Fig. 17, the yoke 322 is in the engaged position, and a broken line 354 illustrates the yoke 322 in the disengaged position. Once the yoke 322 pivots to the disengaged position, the vacuum release member 314 and compression release member 318 no longer contact the cam follower 350. Since the vacuum release member 314 and the compression release member 318 are both interconnected to the yoke 322, the vacuum release member 314 and the compression release member 318 both have the same kick-out speed.

As illustrated in Fig. 16, the vacuum release member 314 and compression release member 318 are oriented in relation to the cam 326 to contact the cam follower 350 and open an exhaust valve during a specific stage of the engine cycle. The vacuum release member 314 contacts the cam follower 350 during the expansion stroke, and the

compression release member 318 contacts the cam follower 350 during the compression stroke. As described above, the exhaust valve closes between the compression release member 318 and the vacuum release member 314, so the cam follower 350 contacts the cam 326 between the compression release member 318 and the vacuum release member
5 314.

Figs. 19-21 illustrate a fourth embodiment of a release member. In Figs. 19-21, a centrifugally responsive vacuum release member 414 and a compression release member 418 are both integrated into a single yoke 422. The yoke 422 is disposed near a cam 426 and a cam shaft 428, and curves around the cam shaft 428. The yoke 422 is pivotally
10 coupled to a cam gear 430 to pivot between an engaged position and a disengaged position.

The yoke 422 is substantially U-shaped, and has an open end 434 and a curved closed end 438 disposed at opposite ends of the yoke 422. In Fig. 20, the vacuum release member 414 is a rounded bulge that extends outward from the curved closed end 438 and projects away from the cam shaft 428. In the illustrated embodiment, the compression
15 release member 418 is also a rounded bulge that extends outward from the curved closed end of the U-shaped yoke 422. The vacuum release member 414 and compression release member 418 both contact a cam follower 442 as the cam gear 430 rotates and the yoke 422 is in the engaged position at engine starting speeds. The vacuum release member 414
20 contacts the cam follower 442 to open an engine valve during the expansion stroke. In the illustrated embodiment, when the cam follower 442 contacts the yoke 422, the closed end 438 contacts the cam shaft 428, which helps support the force exerted on the yoke 422 by the cam follower 442.

Two legs 446 extend from the curved closed end 438 toward the open end 434 of
25 the U-shaped yoke 422. Two flyweight portions 450 are disposed at the ends of the legs 446 near the open end 434. As shown in Fig. 21, each leg 446 has a retaining portion between the closed end 438 and the open end 434. A pin 458 extends through the retaining portion and retains the yoke 422 to the cam gear 430. In the illustrated embodiment, the receiving portions are U-shaped recesses 454. Alternatively, the
30 receiving portions may be holes, as shown in Figs. 15-17. In Figs. 19-21, the recesses 454 are positioned between the pin 458 and the cam gear 430. The yoke 422 pivots about the pin 458 when pivoting between the engaged position and disengaged position. The pin 458 is substantially transverse and non-intersecting to the cam shaft 428. Similarly, the

pivot axis of the yoke 422 is also substantially transverse and non-intersecting to the cam shaft 428.

As illustrated in Figs. 19-21, the pin 458 is substantially C-shaped and has an elongated middle portion 462 and two end portions 466 that extend at an angle to the middle portion 462. The middle portion 462 extends through the recesses 454, and the end portions 466 extend into apertures 470 in the cam gear 430. In the illustrated embodiment, the apertures 470 extend in the axial direction of the cam gear 430 to facilitate the manufacture of the cam gear 430, which is generally made from a molding or casting process. Since the apertures 470 extend in the axial direction, the apertures 470 may be formed with a single pull during the manufacturing of the cam gear 430. If a hole would extend in a direction transverse to the axial direction of the cam gear 430, an additional pull during the gear manufacturing process may be necessary to form the hole. Reducing the number of pulls during manufacturing simplifies manufacturing and reduces the cost of the cam gear 430.

Alternatively, the yoke 422 of the fourth embodiment may be retained to the cam gear 430 with a substantially straight pin, similar to pin 338 described above with the third embodiment and illustrated in Figs. 15-17. In this alternative embodiment, the pin 338 may extend through apertures in the bosses 334 that extend in a direction substantially transverse to the axial direction of the cam gear 330.

In Figs. 19-21, the design of the yoke 422 also simplifies manufacturing and reduces the cost of the yoke 422. The U-shaped recesses 454 that engage the pin 458 may be bent and eliminate the need to form a hole in the yoke 422. The vacuum release member 414 and the compression release member 418 are relatively co-planar with curved closed end 438, and the cam follower 442 contacts the edge of the vacuum release member 414 and compression release member 418. As shown in Fig. 21, the curved closed end 438 is substantially planar, but may have a slightly curved profile.

The yoke 422 may be formed with a stamping process which permits relatively accurate tolerances for the vacuum release member 414 and the compression release member 418. The vacuum release member 414 and compression release member 418 do not have to be bent or machine ground, which eliminates additional machining steps. Also, contact stress on the yoke 422 is reduced because the yoke 422 is not ground. Since the cam follower 442 contacts the edge of the curved closed end 438 and the curved closed end 438 is substantially planar, the force exerted by the cam follower 442 is substantially supported by the pin 458. Therefore, the yoke 422 may support a relatively large amount

of force, and the yoke 422 may not have to be hardened. Additionally, the yoke 422, pin 458 and cam gear 430 are relatively easy to assemble.

The flyweight portions 450 have sufficient mass to function as a flyweight. Once the engine reaches normal engine operating speeds, the flyweight portion 450 is centrifugally forced away from the cam shaft 428, causing the yoke 422 to pivot to the disengaged position. As illustrated in Fig. 21, the yoke 422 is in the engaged position, and a broken line 474 illustrates the yoke 422 in the disengaged position. Once the yoke 422 pivots to the disengaged position, the vacuum release member 414 and compression release member 418 no longer contact the cam follower 442 as the cam gear 430 rotates. Since the vacuum release member 414 and the compression release member 418 are both interconnected to the yoke 422, the vacuum release member 414 and the compression release member 418 both have the same kick-out speed. The cam gear 430 includes a stop 478 to prevent the yoke 422 from pivoting beyond the desired position of the disengaged position.

As illustrated in Fig. 20, the vacuum release member 414 and compression release member 418 are oriented in relation to the cam 426 to contact the cam follower 442 and open an exhaust valve during a specific stage of the engine cycle. The vacuum release member 414 contacts the cam follower 442 during the expansion stroke, and the compression release member 418 contacts the cam follower 442 during the compression stroke. As described above, the exhaust valve closes between the compression stroke and the expansion stroke so the cam follower 442 contacts the cam 426 between the compression release member 418 and the vacuum release member 414.

As described above, the retainer retains the release member to at least one of the cam lobe and the cam gear. In Figs. 1-6, the retainer includes a pin 62 that retains the release member 14 in a slot 58 in the cam 10. The pin 62 is substantially transverse and non-intersecting to the cam shaft 30. Alternatively, the retainer may include nubs that retain the release member 14 within the slot 58, similar to the release member shown in U.S. Patent Application No. 09/782,468 filed February 9, 2001, the entire contents of which are incorporated herein by reference.

The release member may be a vacuum release member 14 or a compression release member 122 to reduce resistance and assist in starting an internal combustion engine. The compression release member 122 is described in more detail in U.S. Patent Application No. 09/782,468 filed February 9, 2001. The release member may also be a vacuum release member or compression release member for stopping or preventing starting of an internal

combustion engine. The release member may also be a low oil sensor release member, as described in U.S. Patent No. 5,301,643, the entire contents of which are incorporated herein by reference, that totally releases compression in the engine combustion chamber to prevent engine running when a low oil condition is sensed.

5 In Figs. 15-17, the retainer includes a pin 338 that retains the yoke 322 adjacent the cam gear 330. The pin 338 extends through a receiving portion of the yoke 322, and is interconnected to bosses 334 that project from the cam gear 330. In the illustrated embodiment, the receiving portions are holes 360. The yoke 322 includes a vacuum release member 314 and a compression release member 318. The yoke 322 at least
10 partially surrounds the cam shaft 328, and the cam shaft 328 may limit the movement of the yoke 322. As mentioned above, the yoke 322 may contact the cam shaft 328 when the yoke 322 is in the engaged position. The cam shaft 328 at least partially supports forces exerted on the yoke 322 by the cam follower 350, and helps relieve stress on the pin 338.

The pin 338 extends through the holes 360 and into apertures 364 in the bosses
15 334. The apertures 364 extend through the bosses 334 in a direction substantially transverse to the axial direction of the cam gear 330. The pin 338 does not pass through the cam shaft 328, and is substantially transverse and non-intersecting to the cam shaft 328. In the illustrated embodiment, the pin 338 has a head 368 at one end with a diameter greater than the diameter apertures 364 in the bosses 334. A stop 372 projects from the
20 cam gear 330 near one of the bosses 334 and helps retain the pin 338. The head 368 catches on the stop 372 as the pin 338 is inserted into the apertures 364, and the stop 372 may prevent the pin 338 from inadvertently sliding out of the apertures 364.

In Figs. 19-21, the retainer includes a pin 458 that retains the yoke 422 adjacent the cam gear 430, and extends through receiving portions in the yoke 422. In the illustrated
25 embodiment, the receiving portions are substantially U-shaped recesses 454. The yoke 422 includes a vacuum release member 414 and a compression release member 418. The yoke 422 at least partially surrounds the cam shaft 428, and the cam shaft 428 may limit the movement of the yoke 422. The yoke 422 may contact the cam shaft 428 when the yoke 422 is in the engaged position. The cam shaft 428 at least partially supports forces
30 exerted on the yoke 422 by the cam follower 442, and helps relieve stress on the pin 458.

In the illustrated embodiment, the pin 458 is substantially C-shaped and extends into apertures 470 in the cam gear 430. The apertures 470 extend in the axial direction of the cam gear 430. The pin 458 may be press-fit into the apertures 470 to properly position the pin 458, similar to a staple. The pin 458 does not pass through the cam shaft 428, and

is substantially transverse and non-intersecting to the cam shaft 428. Alternatively, the retainer could include two separate pins that each extend through one of the recesses 454 to retain the yoke 422 adjacent the cam gear 430.

Fig. 21 illustrates a partial cross-sectional view of the cam gear 430 and pin 462.

5 The end portion 466 includes a barb 478 that helps retain the pin 462 within the aperture 470. The barb 478 provides a tighter fit of the end portions 466 within the apertures 470. The barb 478 may be particularly effective when the cam gear 430 is made from a material that is softer than the material of the pin 458. For example, if the cam gear 430 is made from a plastic material and the pin 458 is made from a metal material, the metal barb 478
10 may engage the plastic cam gear 430 to retain the pin 458 within the aperture 470.

In Figs. 22-24, the retainer includes a pin 510 that retains a yoke 514 adjacent a cam gear 518. The yoke 514 is movable between an engaged position and a disengaged position. The pin 510 extends through receiving portions in the yoke 514. In the illustrated embodiment, the receiving portions are substantially U-shaped recesses 522.
15 The yoke 514 at least partially surrounds a cam shaft 526. The yoke 514 may contact the cam shaft 526 when the yoke 514 is in the engaged position. The cam shaft 526 may at least partially support forces exerted on the yoke 514 by a cam follower, and helps relieve stress on the pin 510.

The pin 510 does not pass through the cam shaft 526, and is substantially
20 transverse and non-intersecting to the cam shaft 526. The pin 510 is substantially C-shaped and includes an elongated middle portion 530 and two end portions 534 that extend at an angle to the middle portion 530. The middle portion 530 extends through the recesses 522, and is substantially transverse and non-intersecting to the cam shaft 526. The end portions 534 extend into apertures 538 in the cam gear 518. As shown in Figs.
25 23-24, the end portions 534 extend through the apertures 538, and push nuts 542 engage the end portions 534 to help retain the pin 510 within the apertures 538.

The push nuts 542 may be particularly useful when the cam gear 518 is made from a material that is similar to, or harder than, the material of the pin 510, or other
embodiments in which press fits or barbs may not be as effective. For example, if the cam
30 gear 518 and pin 510 are made from a metal material, barbs may not engage the metal material of the cam gear 518. Since the end portion 534 extends through the aperture 538, the push nut 542 may engage the end portion 534 on the opposite side of the aperture 538 to retain the pin 510 within the aperture 538.

As shown in Fig. 22 and 24, a biasing member 546 biases the yoke 514 toward an engaged position. The yoke 514 may include a release member, such as a compression release member, a vacuum release member, or other similar release member. Fig. 24 illustrates the yoke 514 in the disengaged position, and a broken line 550 illustrates the engaged position. In the illustrated embodiment, the biasing member 546 is a spring. The biasing member 546 increases the kick-out speed of the yoke 514. Increasing the kick-out speed may prolong the benefits of a release member by decreasing forces required for starting for a longer period of time. Increasing the kick-out speed may also permit the yoke 514 to move to the engaged position sooner during coast-down or stopping to reduce stopping time for the engine.

In Figs. 25-30, the retainer includes a pin 610 that retains a yoke 614 adjacent a cam gear 618. The yoke 614 at least partially surrounds a cam shaft 622, and is movable between an engaged position, in which the yoke 614 is adjacent a cam lobe 626 and a disengaged position, in which the yoke 614 pivots away from the cam lobe 626. The pin 610 extends through receiving portions in the yoke 614. In the illustrated embodiment, the receiving portions are substantially U-shaped recesses 630. The yoke 614 may include a release member 634, such as a compression release member, a vacuum release member, or other similar release members.

As shown in Fig. 25, the release member 634 is disposed near a closed end 638 of the generally U-shaped yoke 614. The yoke 614 may contact the cam shaft 622 when the yoke 614 is in the engaged position, and the cam shaft 622 may at least partially support forces exerted on the yoke 614 by a cam follower or tappet. A stop portion 642 extends inwardly from the closed end 638, away from the release member 634, and toward the cam shaft 622. The yoke 614 includes clearance recesses 646 on both sides of the stop portion 642. The recesses 646 permit the yoke 614 to be bent near the base of the stop portion 642 to position the release member 634 adjacent the cam lobe 626 while the stop portion 642 contacts the cam shaft 622 to support the yoke 614 when the yoke 614 is in the engaged position. Fig. 27 illustrates the yoke 614 in the engaged position with the stop portion 642 contacting the cam shaft 622 and the release member 634 disposed adjacent the cam lobe 626. Fig. 29 illustrates a cross-sectional view of the yoke 614 in the engaged position with the stop portion 642 contacting the cam shaft 622. Fig. 30 illustrates a cross-sectional view of the yoke 614 in the disengaged position with the stop portion 642 pivoted away from the cam shaft 622.

In Figs. 25-30, the pin 610 does not pass through the cam shaft 622, and is substantially transverse and non-intersecting to the cam shaft 622. The pin 610 is substantially C-shaped and includes an elongated middle portion 650 and two end portions 654 that extend at an angle to the middle portion 650. The middle portion 650 extends through the recesses 630, and is substantially transverse and non-intersecting to the cam shaft 622. The middle portion 650 may include an elongated relatively flat portion having rounded edges or a generally elliptical cross-section. The rounded edges permit the yoke 614 to pivot about the middle portion 650. The middle portion 650 may also include spacers 658 that extend outwardly from the middle portion 650. The spacers 658 may properly position the yoke 614 in relation to the pin 610, and may provide additional stiffness for the pin 610.

The end portions 654 extend into apertures 662 in the cam gear 618. In the illustrated embodiment, the end portions 654 include at least one flexible clip 666 having a barb 670 at the end of an extension 674. As the end portion 654 is inserted into the aperture 662, the extension 674 bends inwardly to permit the barb 670 to fit within the aperture 662. Once the end portion 654 extends through the apertures 662, the extension 674 flexes back to the original position, and the barb 670 engages the opposite side of the aperture 662 to help retain the pin 610 to the cam gear 618. To remove the pin 610, the barbs 670 may be bent inwardly to disengage the barbs 670 from the cam gear 618. Once the barbs 670 fit within the aperture 662, the end portion 654 may be removed from the aperture 662.

The flexible clip 666 may be particularly useful when the cam gear 618 is made from a material that is similar to, or harder than, the material of the pin 610, or other embodiments in which press fits may not be as effective. For example, if the cam gear 618 is made from a metal material and the pin 610 is made from a plastic material, the flexible clip 666 would extend through the aperture 662 and retain the pin 610 to the cam gear 618. Fig. 28 illustrates a cross-sectional view in which the barbs 670 retain the end portions 654 within the apertures 662.

As shown in Figs. 25-30, a biasing member 678 may bias the yoke 614 toward the engaged position. As described above, the biasing member 678 may increase the kick-out speed of the yoke 614. Increasing the kick-out speed may prolong the reduction in starting forces during starting of the engine, and may reduce stopping time for the engine during coast-down.

In Figs. 31-33, the retainer includes a pin 710 that retains a yoke 714 adjacent a cam gear 718. The yoke 714 at least partially surrounds a cam shaft 722, and is movable between an engaged position, in which the yoke 714 is adjacent a cam lobe 726 and a disengaged position, in which the yoke 714 pivots away from the cam lobe 726. The pin 710 extends through receiving portions in the yoke 714. In the illustrated embodiment, the receiving portions are substantially U-shaped recesses 730. The yoke 714 may include a release member 734, such as a compression release member, a vacuum release member, or other similar release members. In the illustrated embodiment, the yoke 714 is similar to the yoke 614 (Figs. 25-30) described above.

10 In Figs. 31-33, the pin 710 does not pass through the cam shaft 722, and is substantially transverse and non-intersecting to the cam shaft 722. The pin 710 is an elongated member that is retained by a mount 738 near each end of the pin 710. The mounts 738 are connected to the cam gear 718, and may be formed integral with the cam gear 718. In the illustrated embodiment, the each mount 738 includes two tabs 742 that extend in substantially the same direction as the axial direction of the pin 710, and a stop 15 746 that extends in a direction substantially transverse to the axial direction of the pin 710. The stops 746 retain the pin 710 in the axial direction, and the tabs 742 retain the pin 710 in a lateral direction. The tabs 742 are preferably made from a bendable material, preferably metal. Once the pin 710 is positioned within the mounts 738, the tabs 742 may be bent inwardly toward one another to clamp the pin 710 and retain the pin 710 within the 20 mounts 738.

Fig. 32 illustrates a partial cross-sectional view of the cam gear 718 with the pin 710 within the mount 738. In Fig. 32, the yoke 714 is in the disengaged position. Fig. 33 also illustrates a cross-sectional view of the pin 710 within the mounts 738. The tabs 742 preferably extend outwardly from the cam gear 718 and beyond the pin 710. The stops 746 are disposed adjacent the ends of the pin 710. As shown in Figs. 31-33, a biasing member 750 may bias the yoke 714 toward the engaged position. As described above, the biasing member 750 may increase the kick-out speed of the yoke 714. Increasing the kick-out speed may prolong the reduction in starting forces during starting of the engine, and 30 may reduce stopping time for the engine during coast-down.

The foregoing detailed description describes only a few of the many forms that the present invention can take, and should therefore be taken as illustrative rather than limiting. It is only the following claims, including all equivalents that are intended to define the scope of the invention.

CLAIMS:

1. A retainer that retains a release member in an internal combustion engine, the retainer comprising:
 - a cam shaft;
 - 5 a cam assembly that includes a cam lobe and a cam driving member; and
 - a pin that is substantially transverse and non-intersecting to the cam shaft, and that interconnects the release member to the cam assembly.
2. The retainer of claim 1, wherein the release member is centrifugally
10 responsive, and pivots about the pin between a first position and a second position.
3. The retainer of claim 1, wherein the release member is a compression release member that at least partially releases compression in an engine combustion chamber.
15
4. The retainer of claim 1, wherein the release member is a vacuum release member that at least partially releases a partial vacuum in an engine combustion chamber.
5. The retainer of claim 1, wherein the release member includes a
20 substantially U-shaped yoke comprising:
 - a first end, and a second end opposite the first end;
 - at least two legs extending between the first end and the second end; and
 - a receiving portion in each leg, wherein the pin is at least partially disposed in at least one of the receiving portions.
25
6. The retainer of claim 5, wherein each receiving portion includes an aperture.
7. The retainer of claim 5, wherein each receiving portion includes a
30 substantially U-shaped recess.
8. The retainer of claim 1, wherein the pin is substantially C-shaped and the pin extends into at least one aperture in the cam driving member that extends in the substantially axial direction of the cam driving member.

9. The retainer of claim 8, wherein the pin includes an elongated middle portion that is substantially transverse and non-intersecting to the cam shaft, and at least one end portion at an end of the pin that extends at an angle to the middle portion, wherein
5 the at least one end portion extends into an aperture in the cam driving member.

10. The retainer of claim 9, wherein the end portion includes a barb that engages the cam driving member to retain the end portion within the aperture.

10 11. The retainer of claim 9, wherein the end portion extends completely through the aperture, and a nut engages the end portion on the opposite side of the cam driving member from the middle portion to retain the end portion within the aperture.

15 12. The retainer of claim 9, wherein the end portion includes a flexible extension having a barb disposed at the end of the extension, and wherein the extension bends inwardly to permit the end portion to be inserted into the aperture, and bends outwardly after it passes through the aperture to engage the cam driving member and retain the end portion within the aperture.

20 13. The retainer of claim 1, wherein the pin is substantially straight, and the cam driving member includes at least one boss projecting from the cam driving member, and the at least one aperture extends into the boss in a direction substantially transverse to the axial direction of the cam driving member.

25 14. The retainer of claim 1, wherein the pin is substantially straight, and the cam driving member includes at least one mount projecting from the cam driving member, the mount including two bendable tabs that project on opposite sides of the pin and clamp the pin to the cam driving member.

30 15. The retainer of claim 1, wherein said cam driving member includes a cam gear.

16. A release member assembly in an internal combustion engine comprising:
a cam shaft;
a cam assembly including a cam lobe and a cam driving member;
a release member that pivots about a pivot axis that is substantially transverse and
5 non-intersecting to the cam shaft; and
a retainer that pivotally interconnects the release member to the cam assembly.

17. The release member assembly of claim 16, wherein the retainer includes at
least two nubs interconnected to at least one of the cam lobe and the cam driving member.
10

18. The release member assembly of claim 16, wherein the retainer includes at
least one pin that is transverse and non-intersecting to the cam shaft.

19. The release member assembly of claim 16, wherein the release member is a
15 compression release member that at least partially releases compression in an engine
combustion chamber.

20. The release member assembly of claim 16, wherein the release member is a
vacuum release member that at least partially releases a partial vacuum in an engine
20 combustion chamber.

21. The release member assembly of claim 16, wherein the release member
includes a substantially U-shaped yoke comprising:
a first end, and a second end opposite the first end;
25 at least two legs extending between the first end and the second end; and
a receiving portion in each leg, wherein the retainer is at least partially disposed in
at least one of the receiving portions.

22. The release member assembly of claim 21, wherein each receiving portion
30 is an aperture.

23. The release member assembly of claim 21, wherein each receiving portion
includes a substantially U-shaped recess.

24. The release member assembly of claim 16, wherein the retainer includes a substantially C-shaped pin having an elongated middle portion that is substantially transverse and non-intersecting to the cam shaft, and at least one end portion at an end of the pin that extends at an angle to the middle portion, wherein the at least one end portion
5 extends into an aperture in the cam driving member that extends in the substantially axial direction of the cam driving member.

25. The release member assembly of claim 16, wherein the cam driving member includes a cam gear.

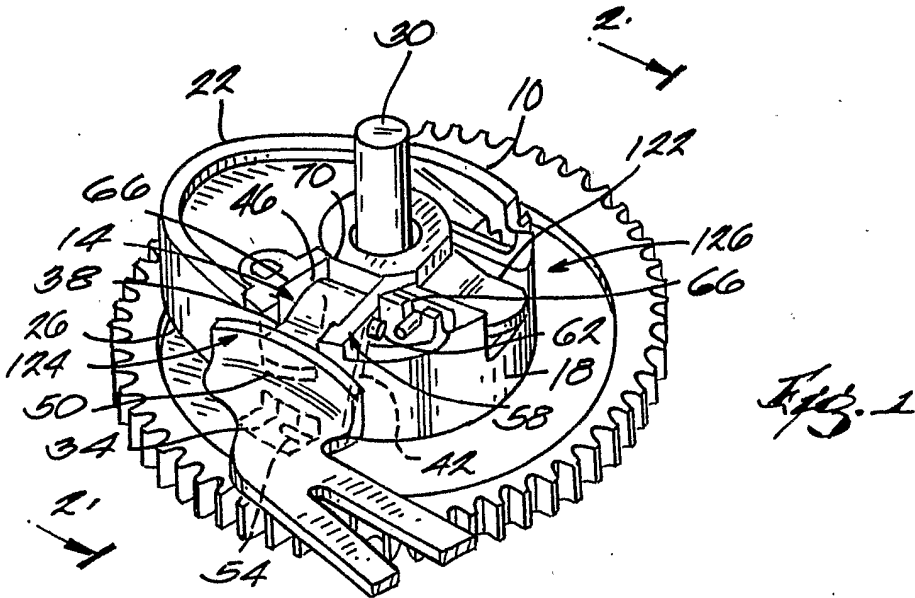

Fig. 1

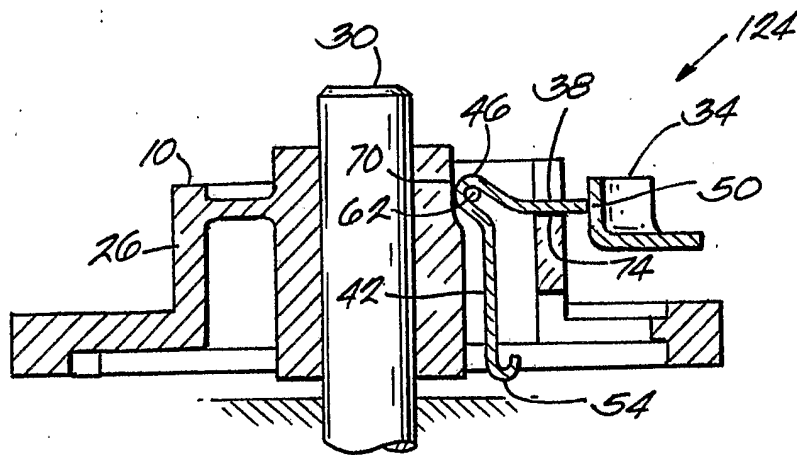

Fig. 2.

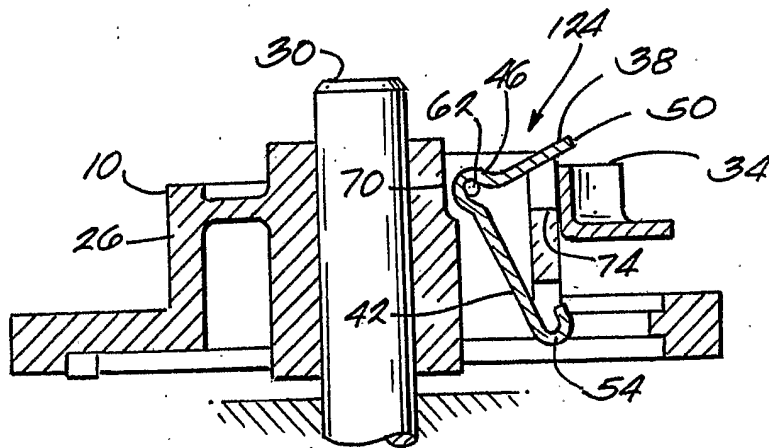
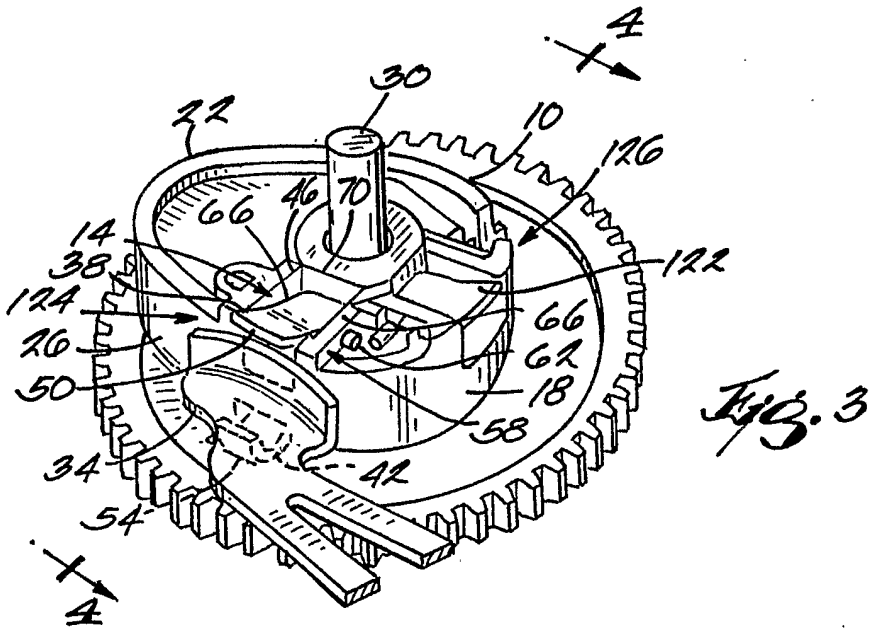

Fig. 4

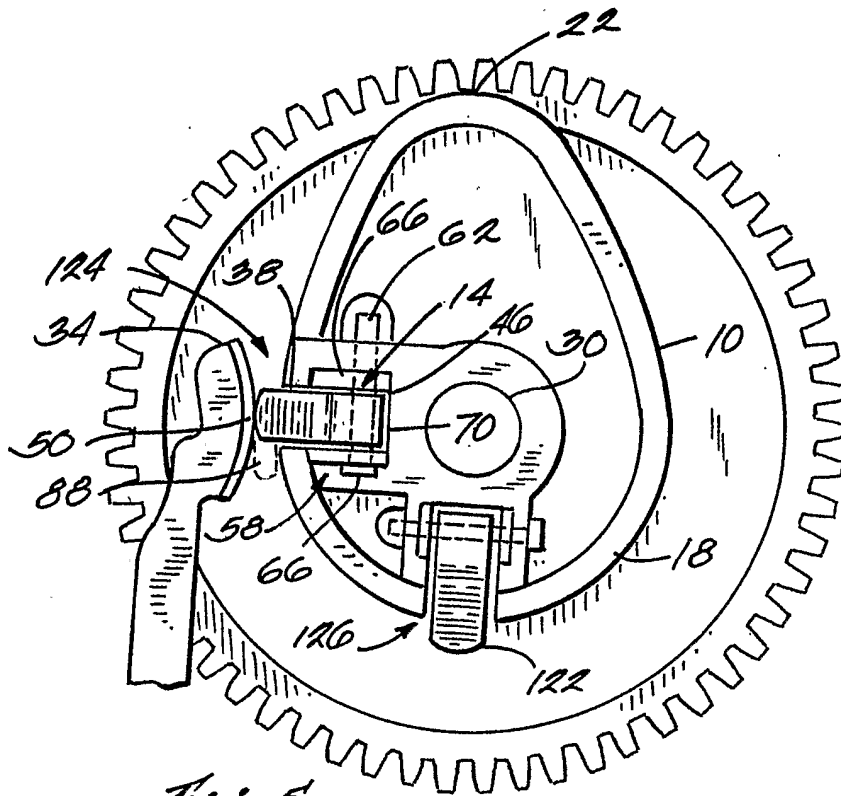

Fig. 5

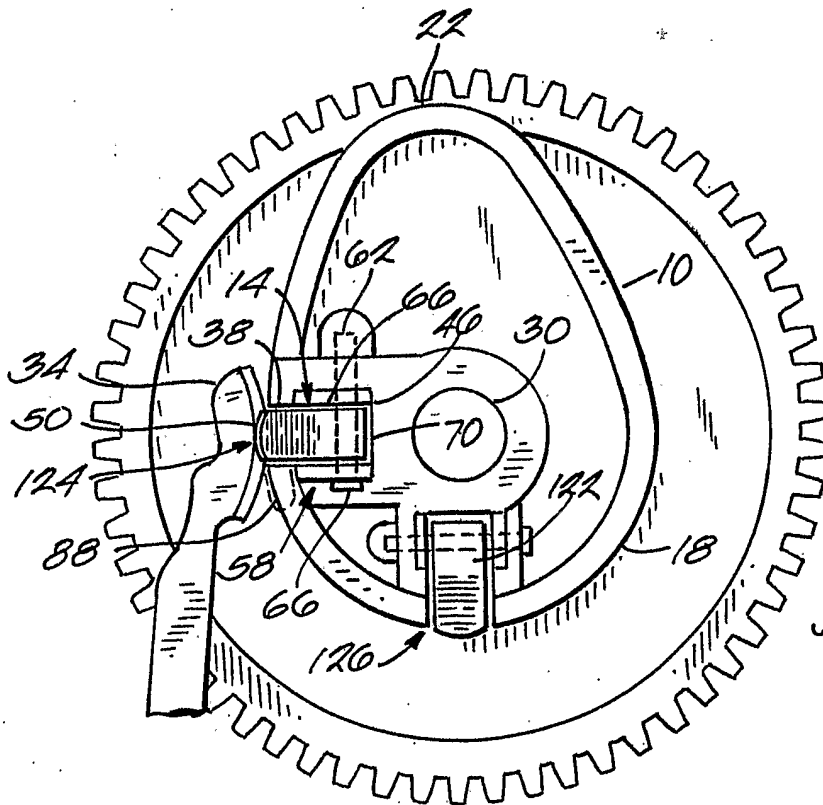

Fig. 6

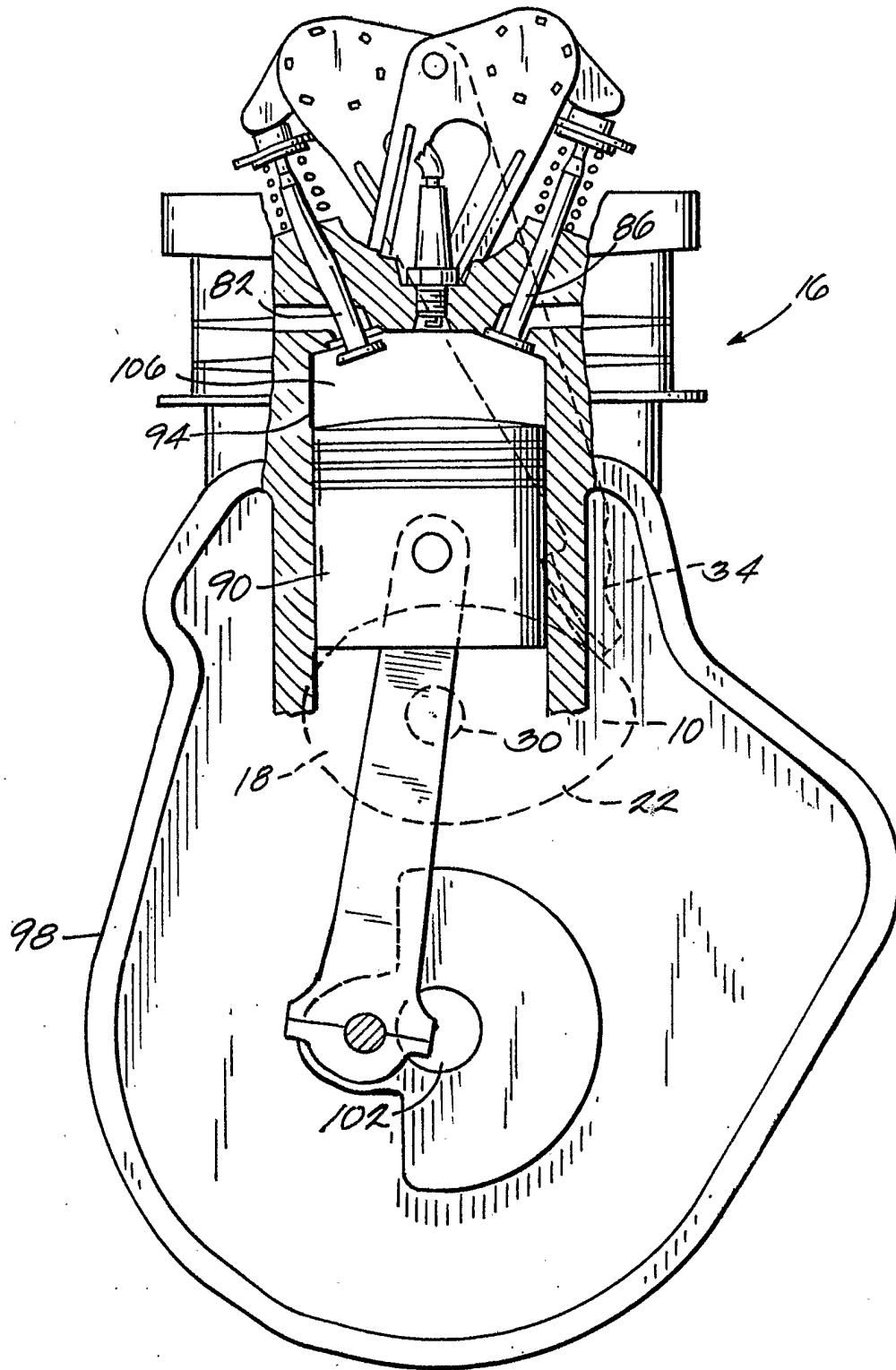

Fig. 1

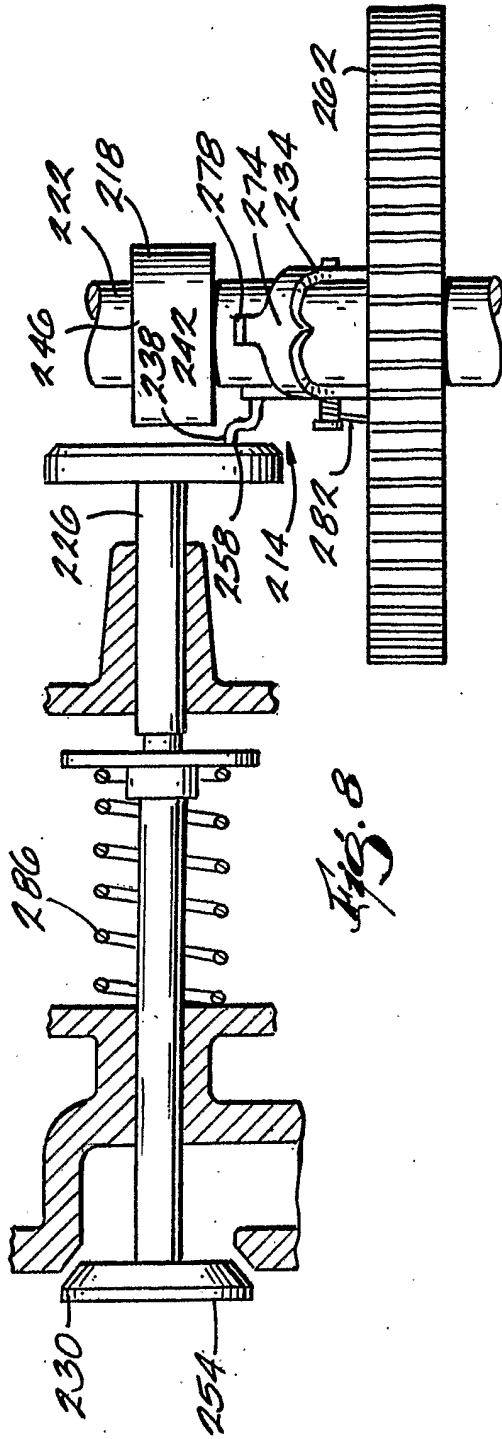

Fig. 8

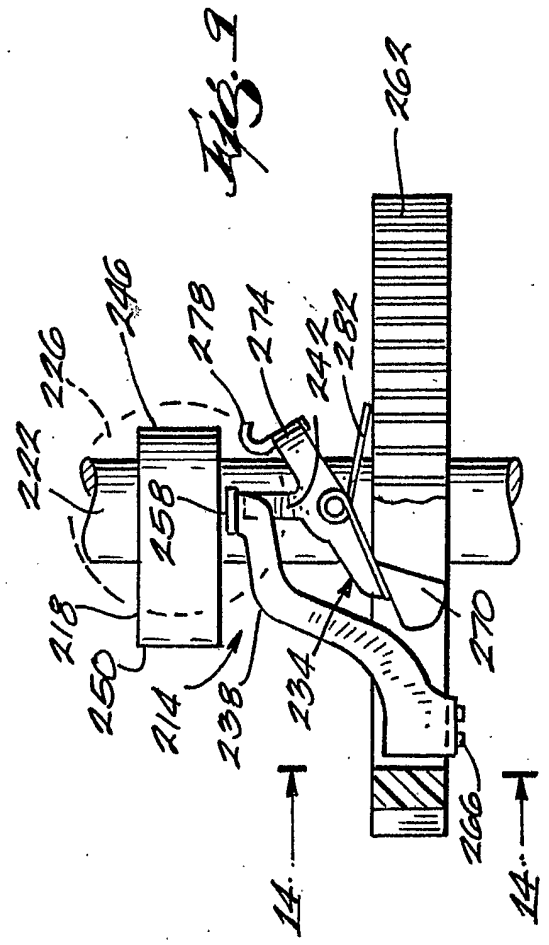
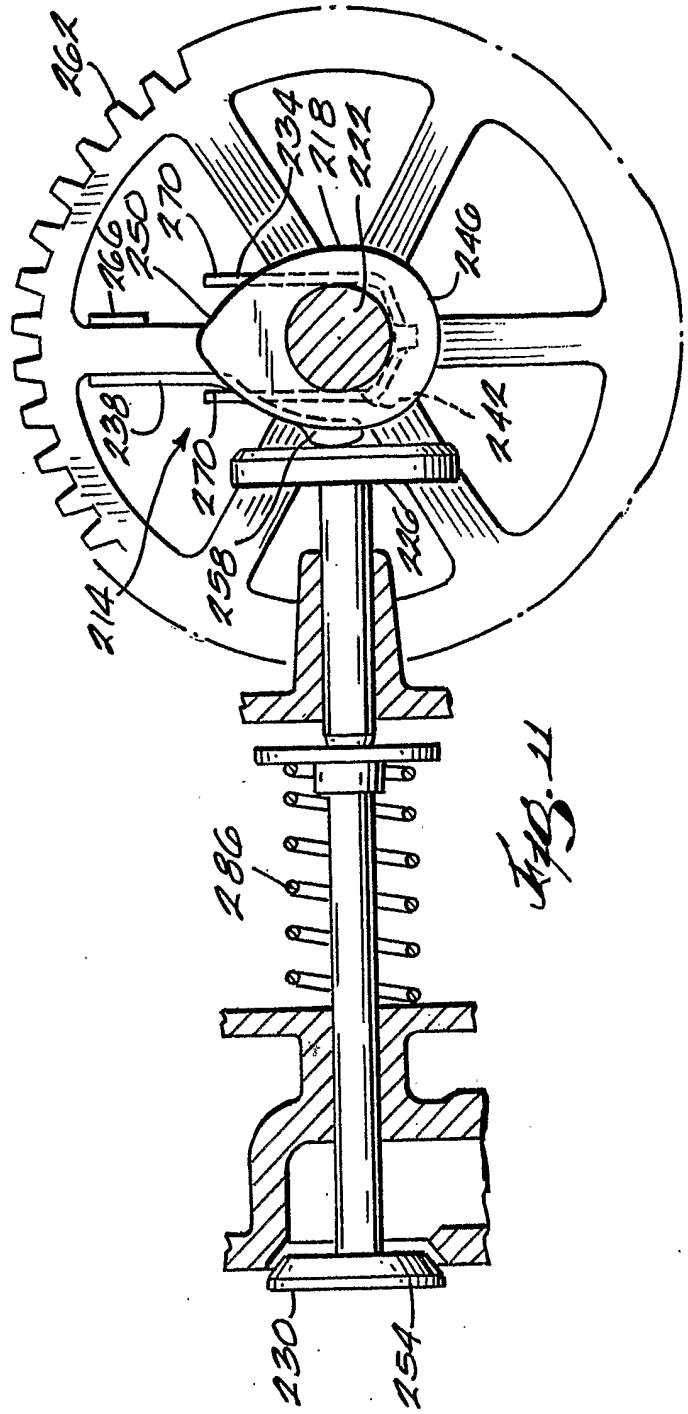
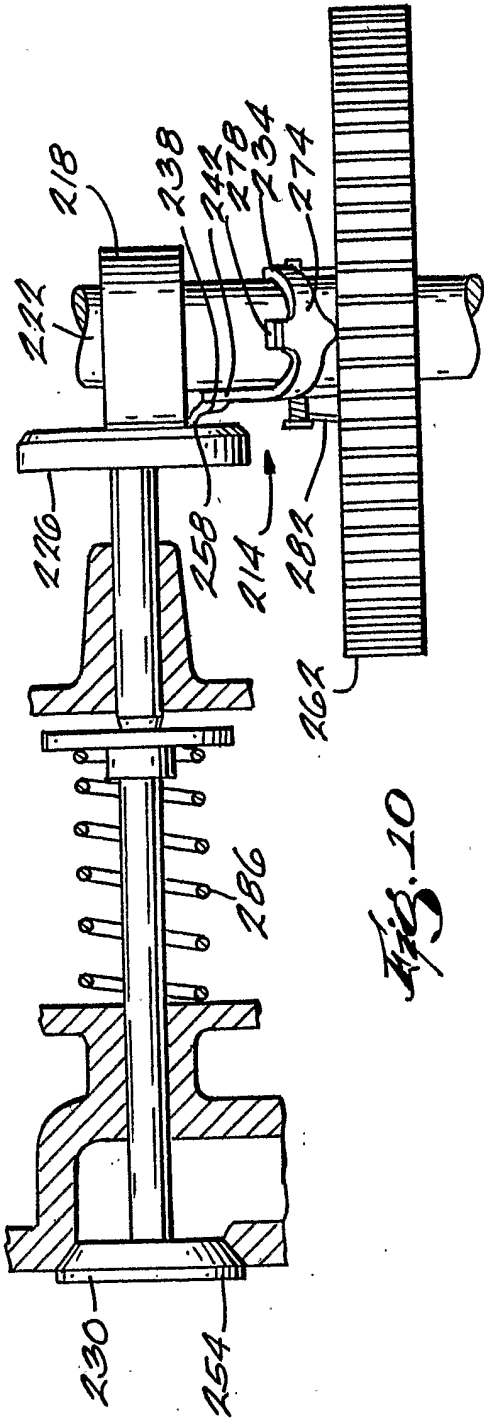

Fig. 9



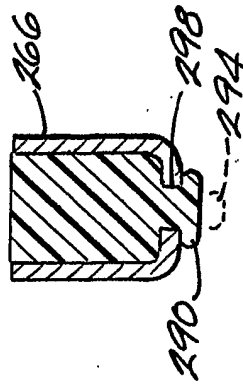
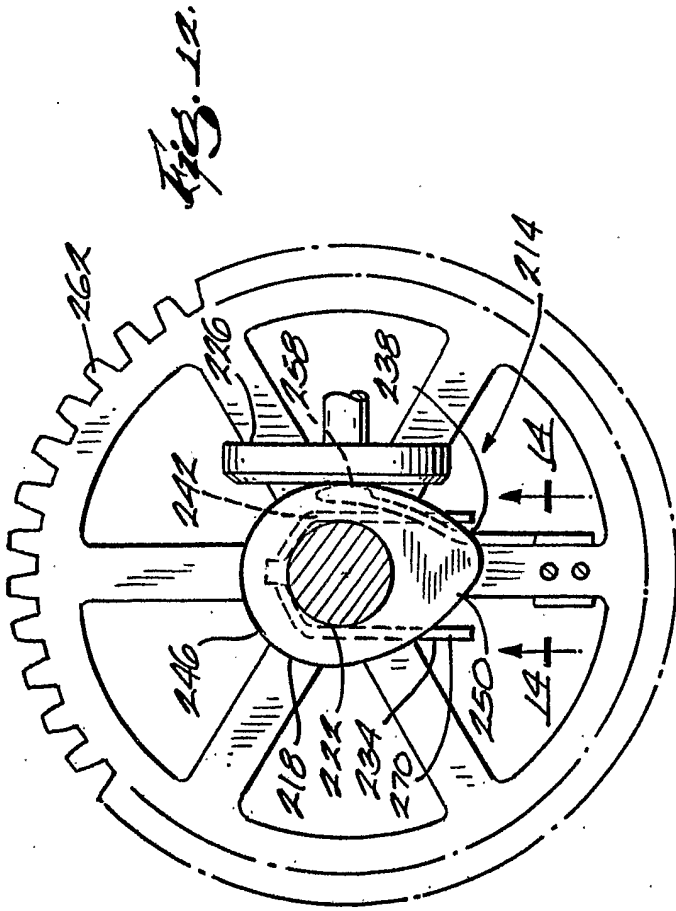

FIG. 14

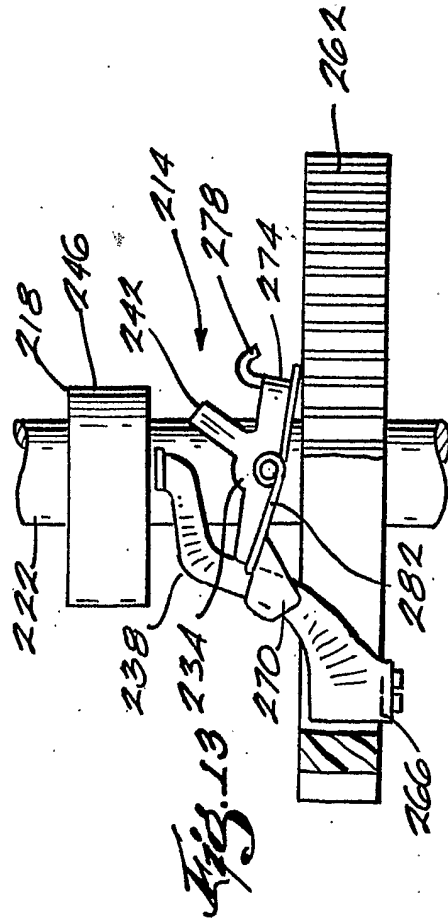
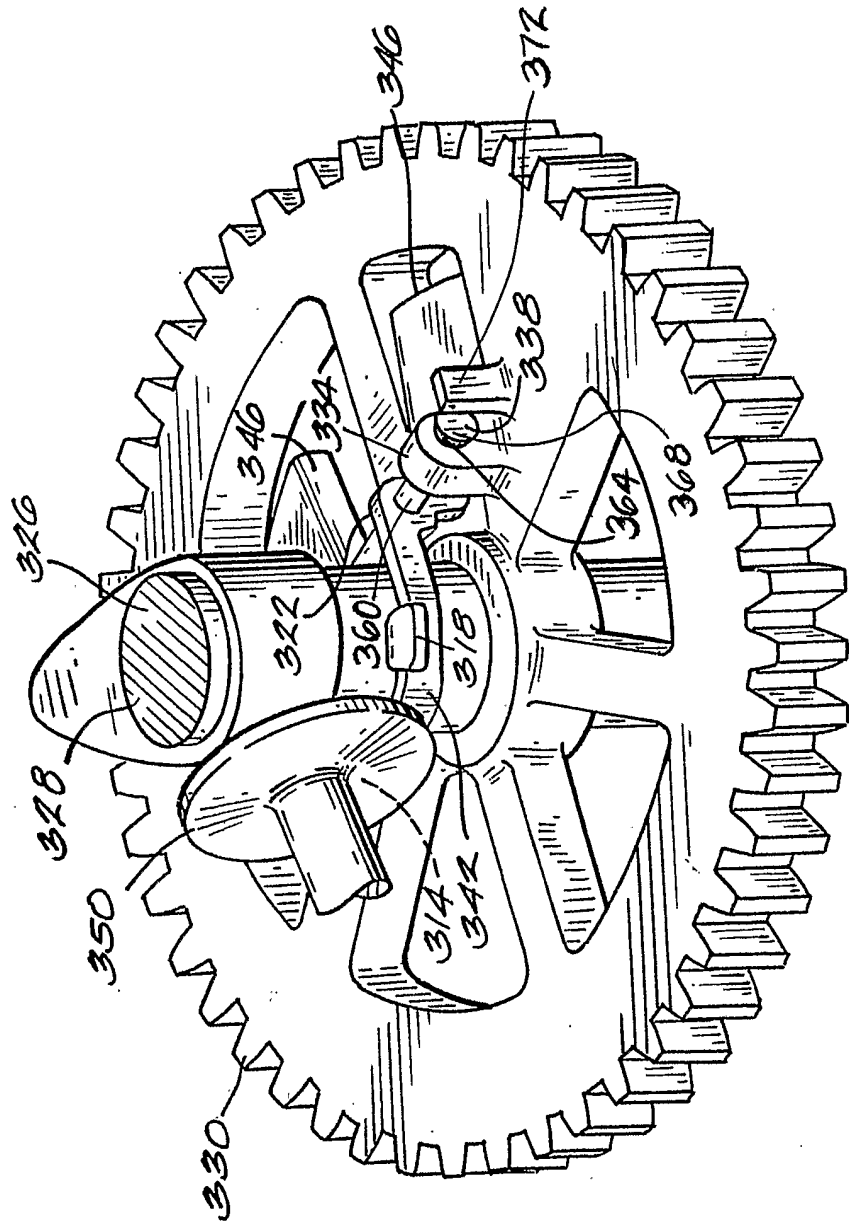

Fig. 15



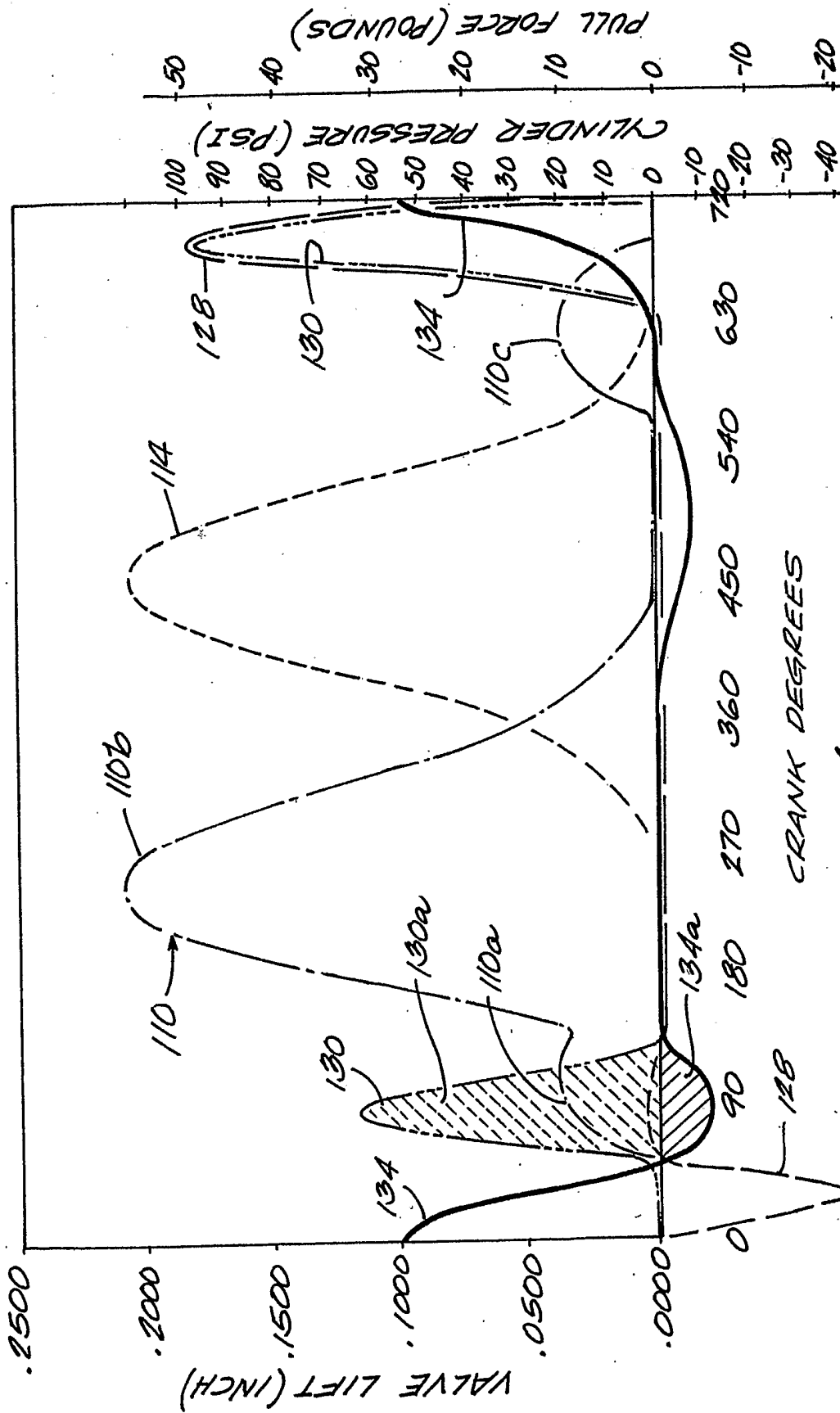
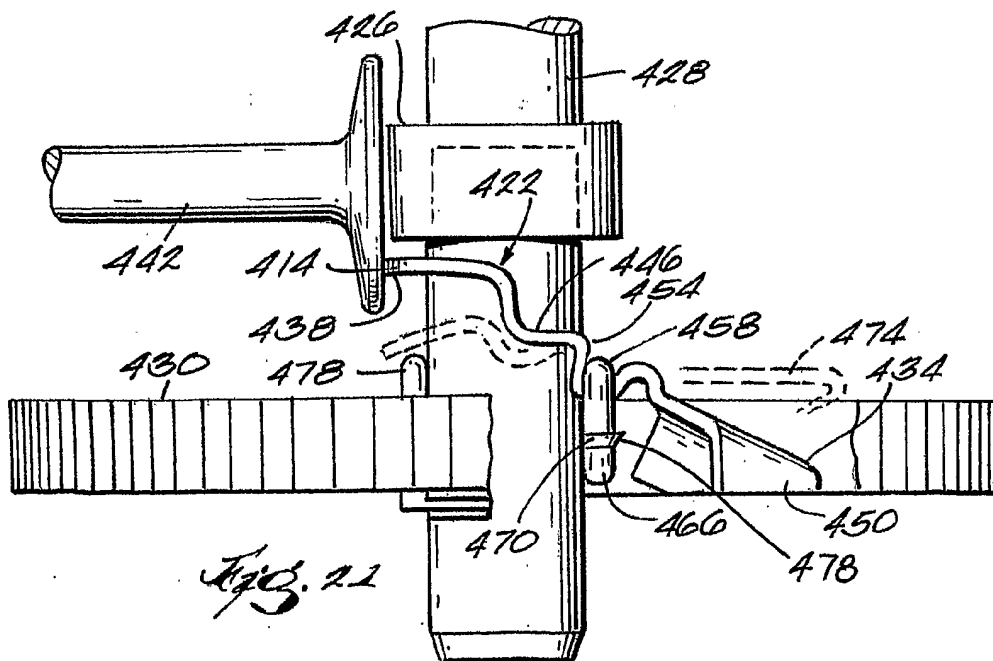
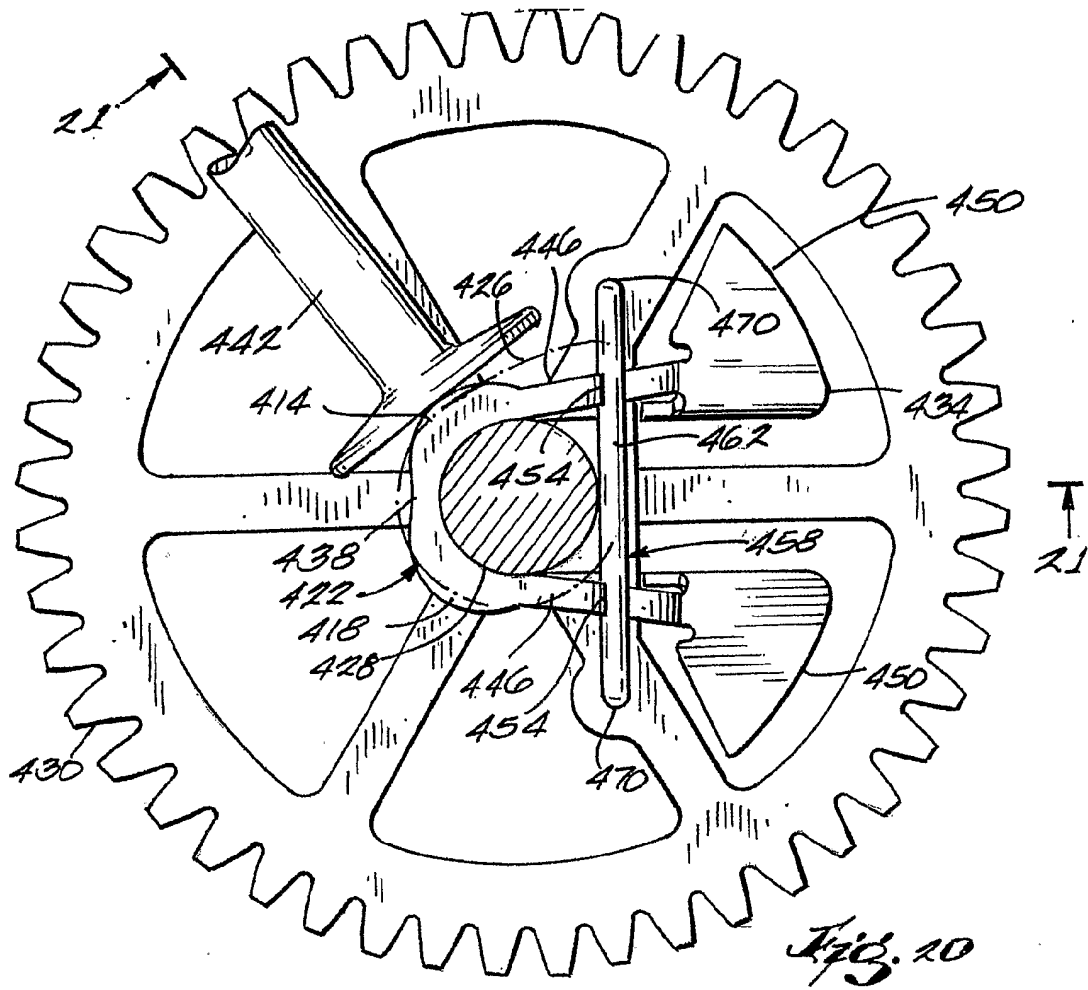

Fig. 18



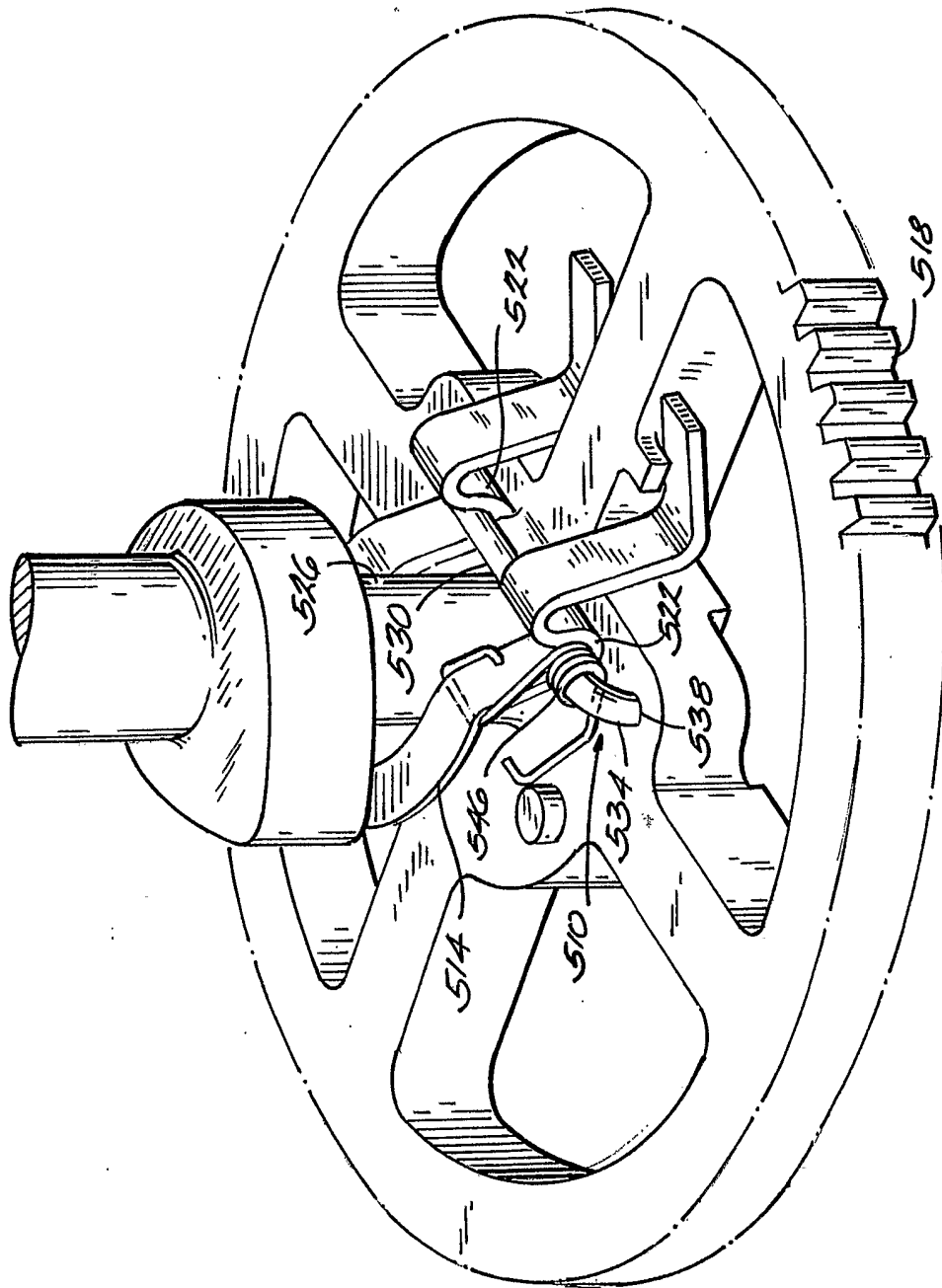
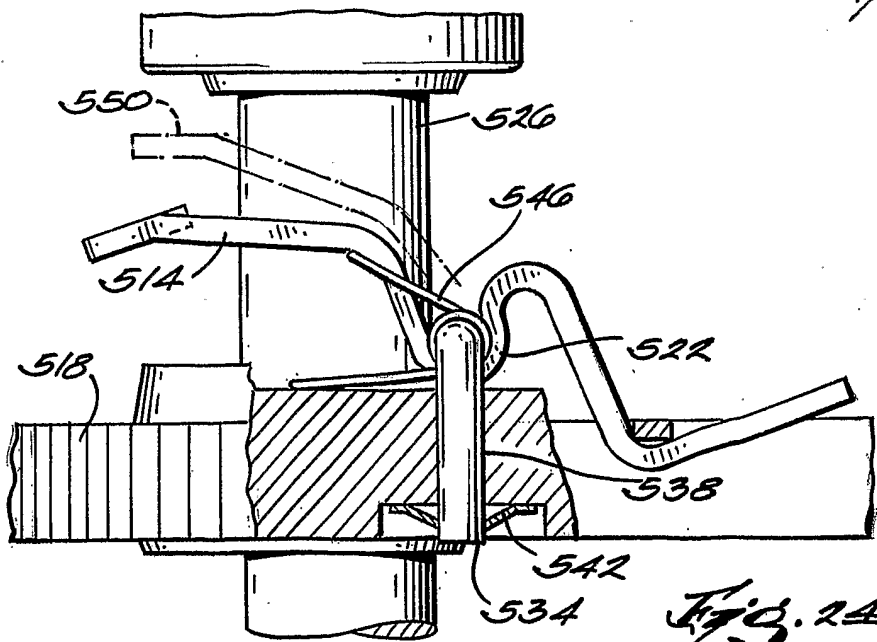
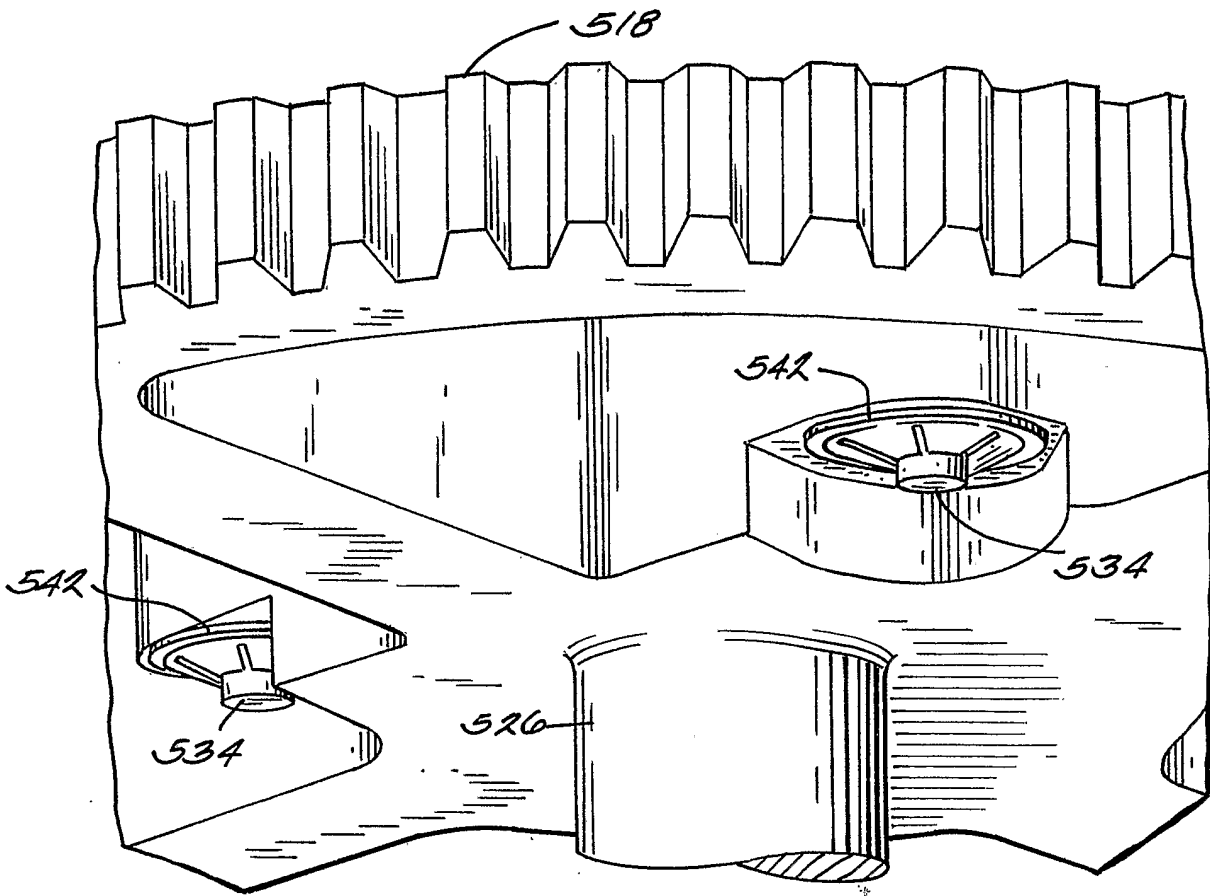
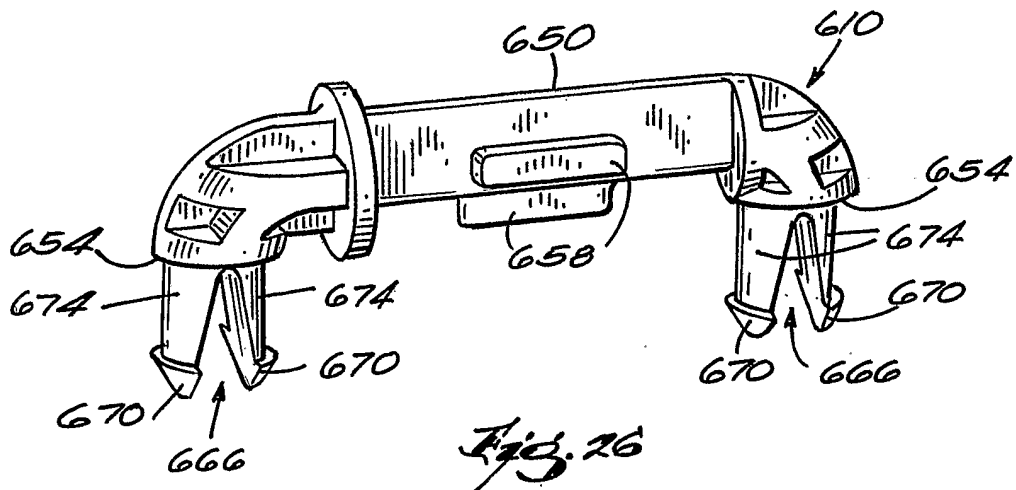
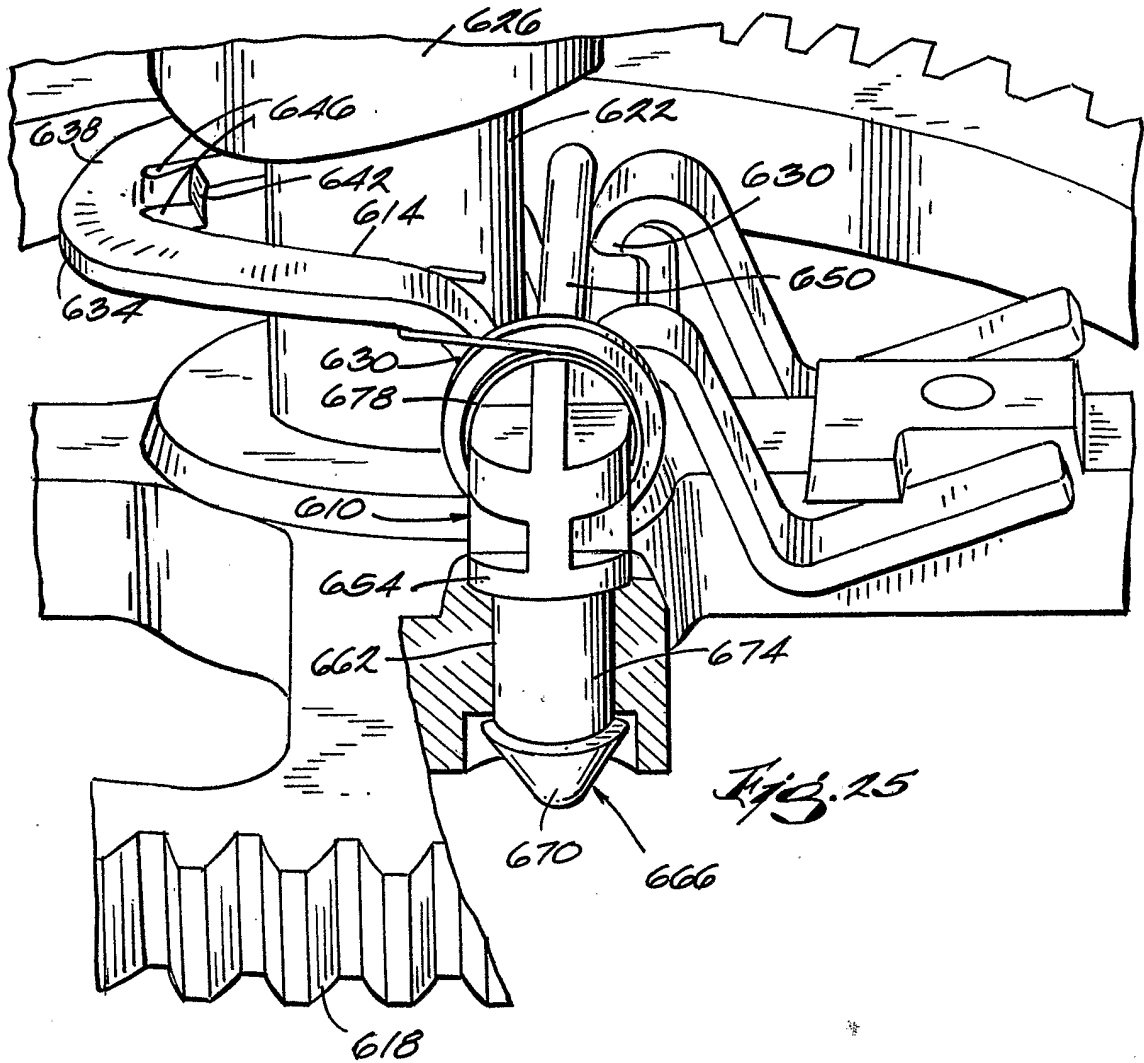
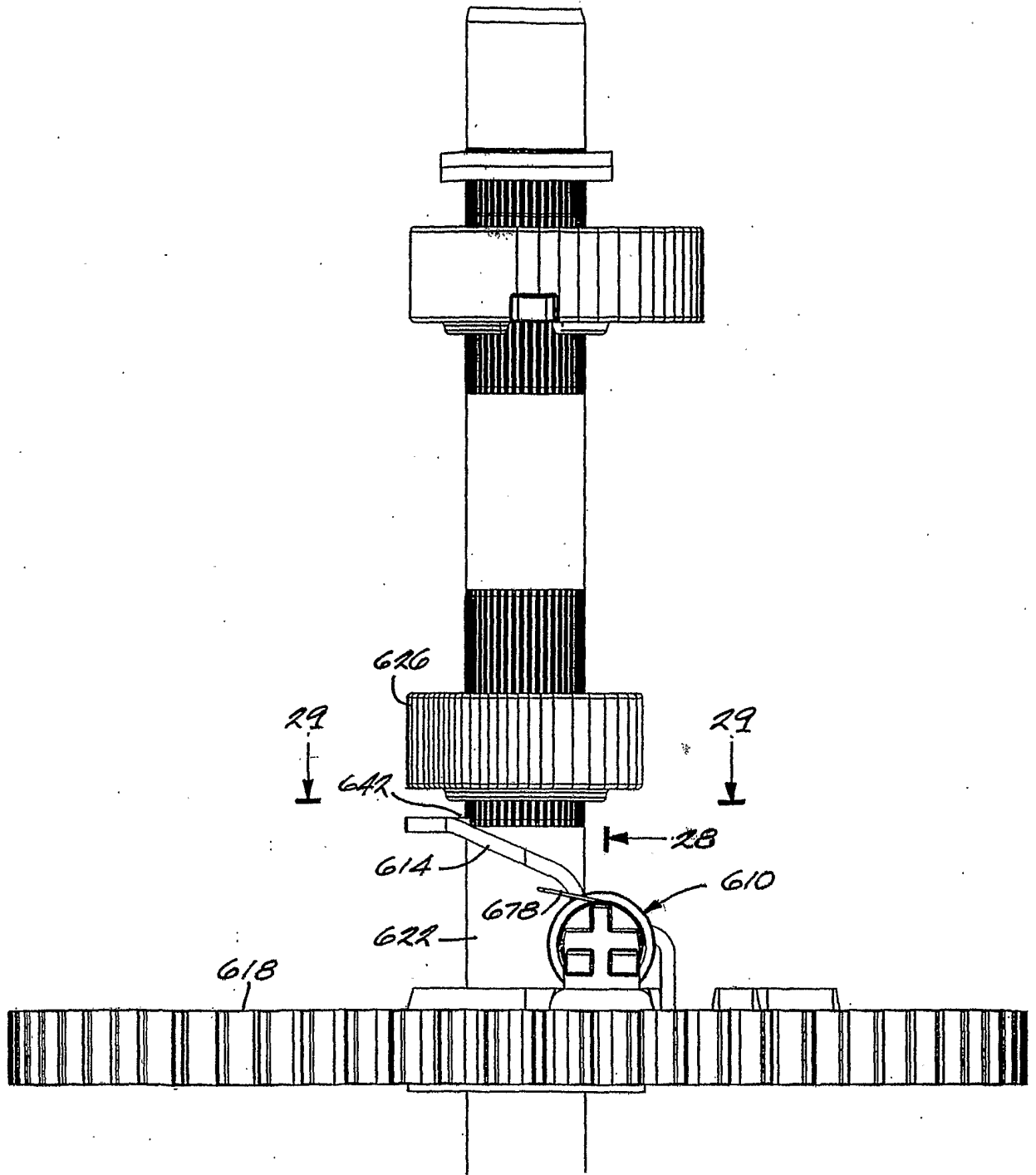

Fig. 22.







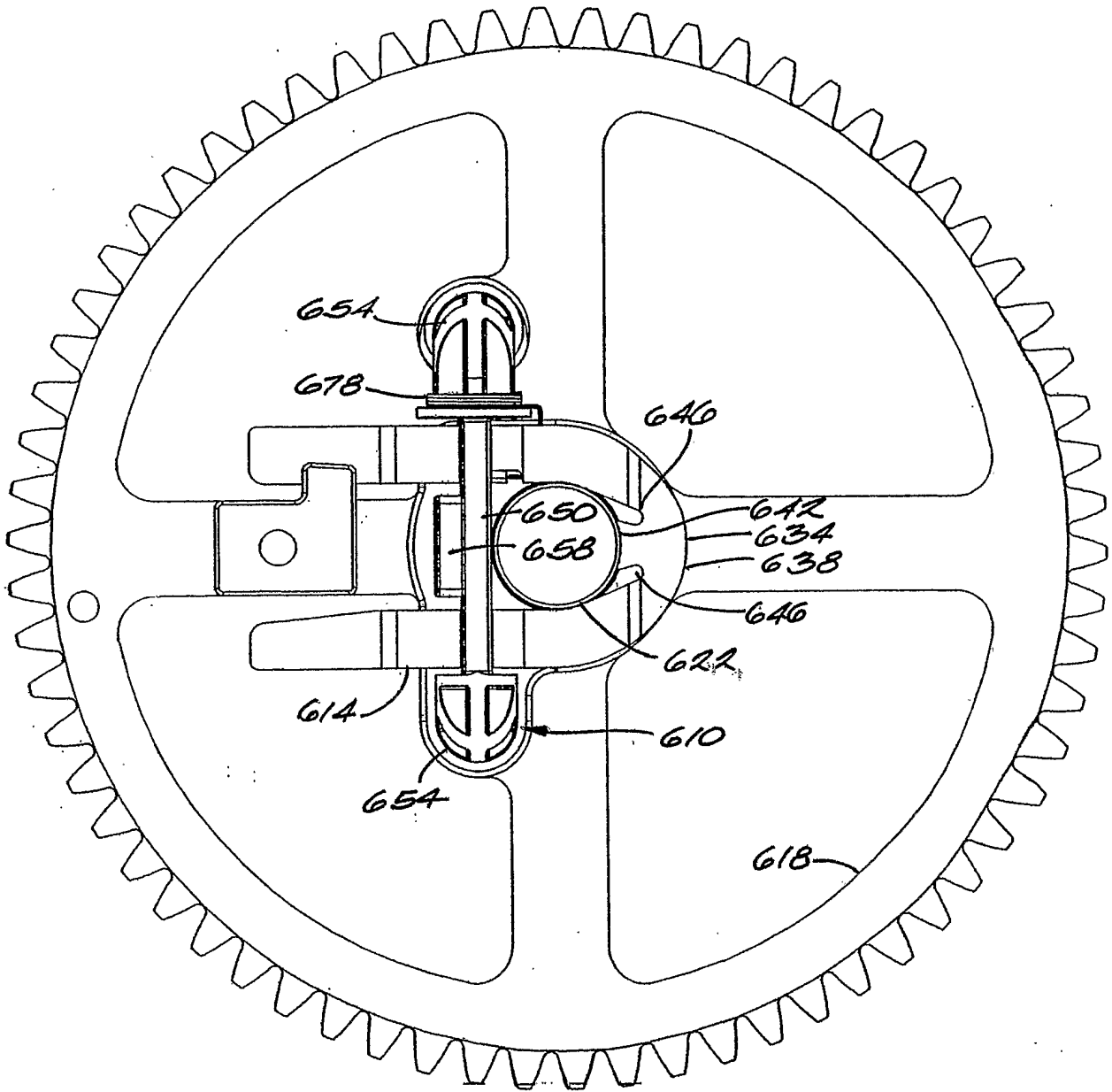

Fig. 29

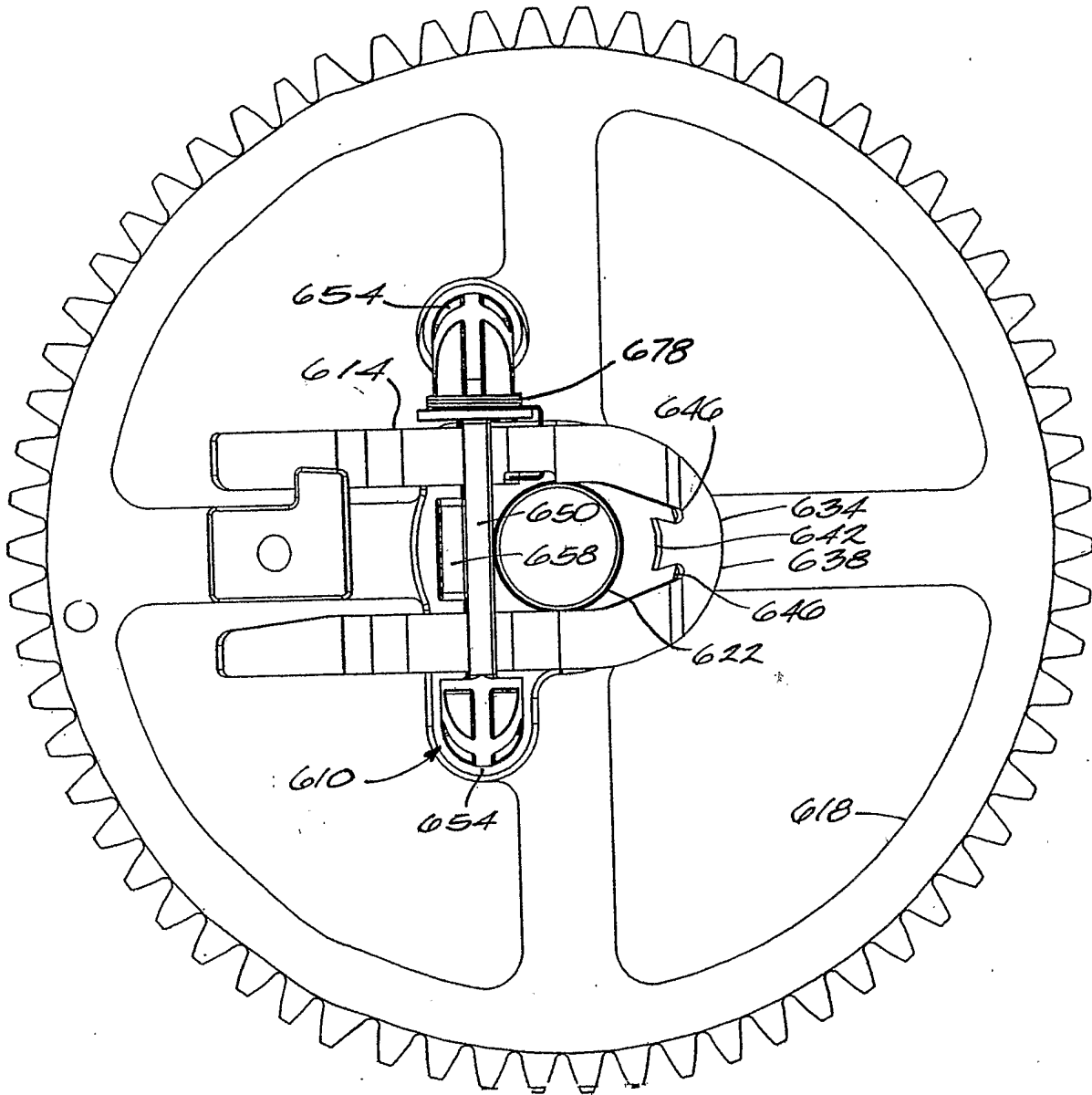

Fig. 30

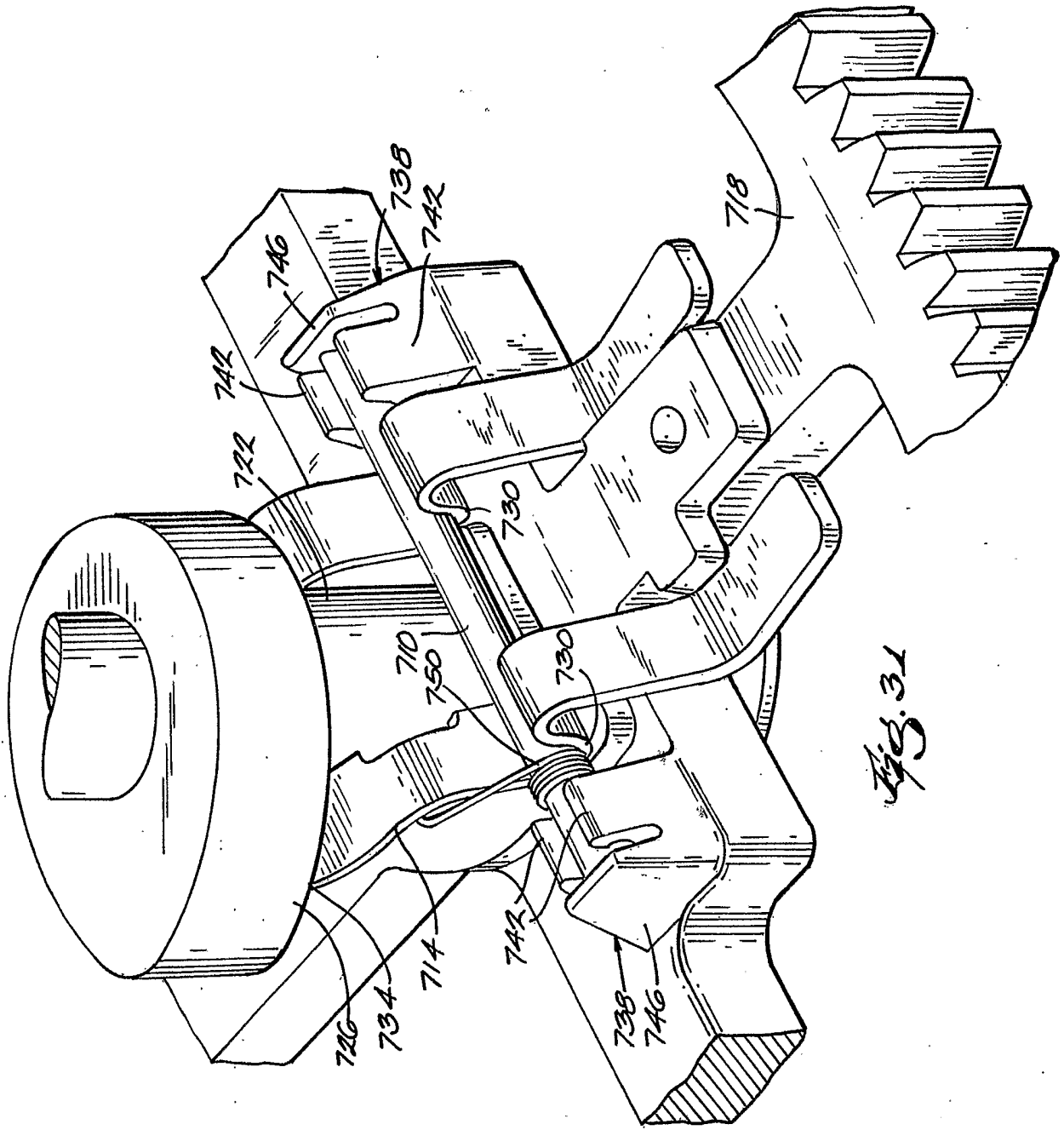

FIG. 31

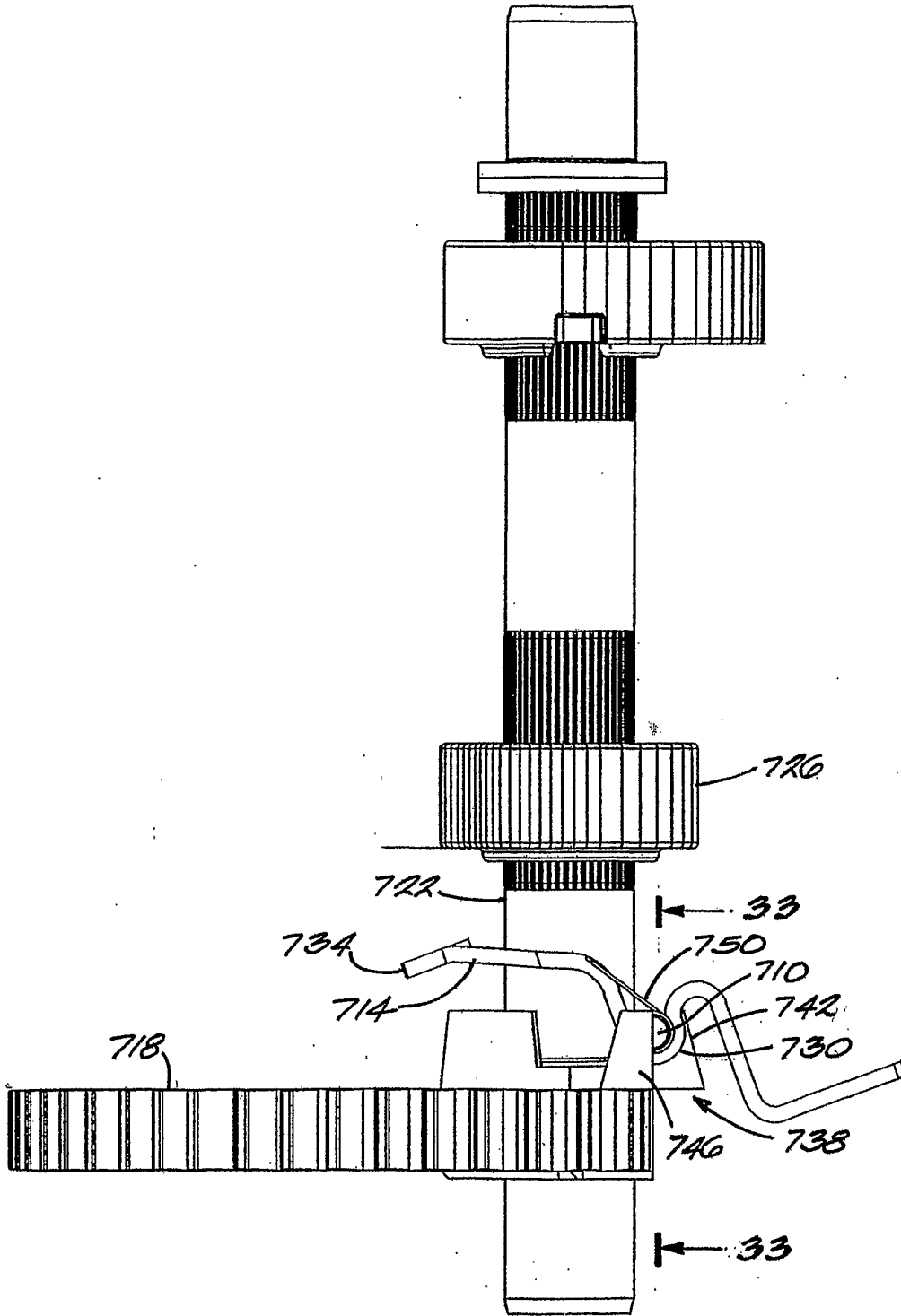

Fig. 32.

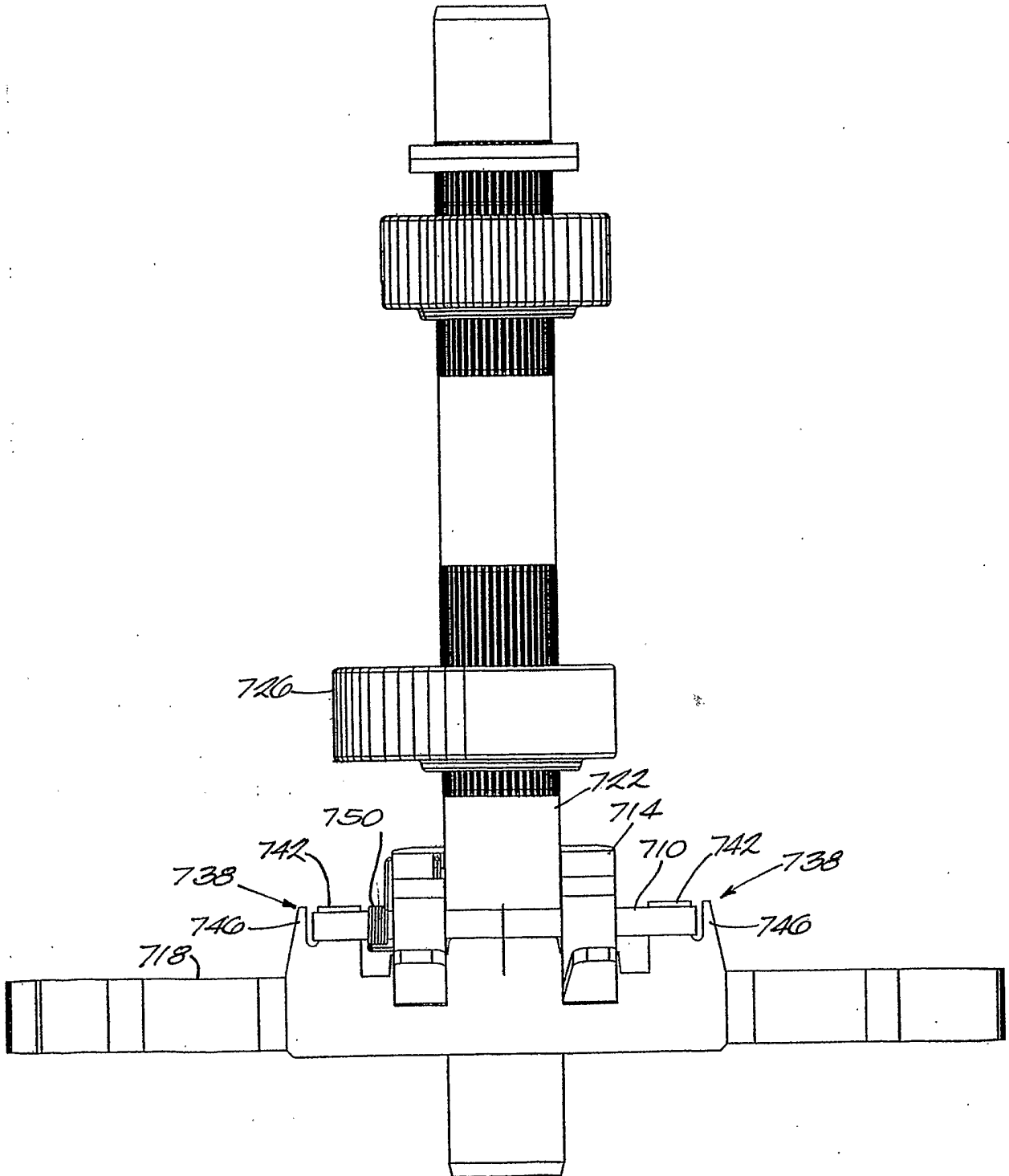

Fig. 33

INTERNATIONAL SEARCH REPORT

Intern: Application No
PCT/US 03/23711

A. CLASSIFICATION OF SUBJECT MATTER
IPC 7 F01L13/08

According to International Patent Classification (IPC) or to both national classification and IPC

B. FIELDS SEARCHED

Minimum documentation searched (classification system followed by classification symbols)
IPC 7 F01L

Documentation searched other than minimum documentation to the extent that such documents are included in the fields searched

Electronic data base consulted during the international search (name of data base and, where practical, search terms used)

EPO-Internal

C. DOCUMENTS CONSIDERED TO BE RELEVANT

Category *	Citation of document, with indication, where appropriate, of the relevant passages	Relevant to claim No.
E	EP 1 344 905 A (BRIGGS & STRATTON CORP) 17 September 2003 (2003-09-17) the whole document ---	1-10, 13, 15, 16, 18-25
X	WO 01 61157 A (BRIGGS & STRATTON CORP) 23 August 2001 (2001-08-23) the whole document ---	1-5, 16-19, 21, 25 13
Y	EP 1 186 754 A (TECUMSEH PRODUCTS CO) 13 March 2002 (2002-03-13) claims 1,2; figures 3-5 ---	13
A	EP 0 515 183 A (BRIGGS & STRATTON CORP) 25 November 1992 (1992-11-25) claim 1; figures 1,6 ---	1-25
A	EP 0 515 183 A (BRIGGS & STRATTON CORP) 25 November 1992 (1992-11-25) claim 1; figures 1,6 ---	5-7, 13
	-/--	

Further documents are listed in the continuation of box C.

Patent family members are listed in annex.

* Special categories of cited documents :

- *A* document defining the general state of the art which is not considered to be of particular relevance
- *E* earlier document but published on or after the international filing date
- *L* document which may throw doubts on priority claim(s) or which is cited to establish the publication date of another citation or other special reason (as specified)
- *O* document referring to an oral disclosure, use, exhibition or other means
- *P* document published prior to the international filing date but later than the priority date claimed

- *T* later document published after the international filing date or priority date and not in conflict with the application but cited to understand the principle or theory underlying the invention
- *X* document of particular relevance; the claimed invention cannot be considered novel or cannot be considered to involve an inventive step when the document is taken alone
- *Y* document of particular relevance; the claimed invention cannot be considered to involve an inventive step when the document is combined with one or more other such documents, such combination being obvious to a person skilled in the art.
- * & * document member of the same patent family

Date of the actual completion of the international search

Date of mailing of the international search report

18 November 2003

27/11/2003

Name and mailing address of the ISA

European Patent Office, P.B. 5818 Patentlaan 2
NL - 2280 HV Rijswijk
Tel. (+31-70) 340-2040, Tx. 31 651 epo nl,
Fax: (+31-70) 340-3016

Authorized officer

Clot, P

INTERNATIONAL SEARCH REPORT

International Application No

PCT/US 03/23711

C.(Continuation) DOCUMENTS CONSIDERED TO BE RELEVANT

Category °	Citation of document, with indication, where appropriate, of the relevant passages	Relevant to claim No.
A	US 4 453 507 A (BRAUN DANIEL E ET AL) 12 June 1984 (1984-06-12) cited in the application the whole document -----	1,16
A	US 5 301 643 A (GARCYALNY GARY J) 12 April 1994 (1994-04-12) cited in the application the whole document -----	1,16

INTERNATIONAL SEARCH REPORT

Information on patent family members

International Application No

PCT/US 03/23711

Patent document cited in search report		Publication date	Patent family member(s)	Publication date
EP 1344905	A	17-09-2003	US 2002108596 A1	15-08-2002
			EP 1344905 A2	17-09-2003
			US 2003024495 A1	06-02-2003
			US 2003000493 A1	02-01-2003
WO 0161157	A	23-08-2001	US 6349688 B1	26-02-2002
			US 2002108595 A1	15-08-2002
			AU 4716701 A	27-08-2001
			AU 5788501 A	27-08-2001
			BR 0017121 A	25-02-2003
			CA 2400098 A1	23-08-2001
			EP 1255915 A2	13-11-2002
			EP 1255916 A1	13-11-2002
			JP 2003522891 T	29-07-2003
			WO 0161153 A2	23-08-2001
			WO 0161157 A1	23-08-2001
			US 2003024495 A1	06-02-2003
			US 2002108596 A1	15-08-2002
			US 2003000493 A1	02-01-2003
EP 1186754	A	13-03-2002	US 2002033158 A1	21-03-2002
			AU 752898 B2	03-10-2002
			AU 6997501 A	14-03-2002
			CA 2356569 A1	11-03-2002
			EP 1186754 A2	13-03-2002
EP 0515183	A	25-11-1992	US 5150674 A	29-09-1992
			CA 2068955 A1	22-11-1992
			EP 0515183 A1	25-11-1992
			JP 6294309 A	21-10-1994
US 4453507	A	12-06-1984	NONE	
US 5301643	A	12-04-1994	NONE	