



US00D401034S

United States Patent [19]

[11] Patent Number: **Des. 401,034**

Marcel

[45] Date of Patent: ****Nov. 10, 1998**

[54] **COMBINED APRON AND FRONT WHEEL ASSEMBLY FOR A HANDPOWERED PALETT TRUCK**

D. 222,670 11/1971 Goodacre et al. D34/34
D. 370,761 6/1996 Stark D34/28

[75] Inventor: **Lüthy André Marcel**, Ulm, Germany

Primary Examiner—Doris Clark
Attorney, Agent, or Firm—Amster, Rothstein & Ebenstein

[73] Assignee: **Mecanique Industrie chimie-Mic**, Rungis, France

[57] **CLAIM**

[**] Term: **14 Years**

The ornamental design for a combined apron and front wheel assembly for a handpowered palett truck, as shown and described.

[21] Appl. No.: **63,986**

DESCRIPTION

[22] Filed: **Dec. 20, 1996**

[30] **Foreign Application Priority Data**

Jun. 21, 1996 [FR] France 963673

[51] **LOC (6) Cl.** **12-05**

[52] **U.S. Cl.** **D34/28**

[58] **Field of Search** D34/37, 35, 28,
D34/34; 108/51.1

FIG. 1 is a perspective view from the front, top and side of a combined apron and front wheel assembly for a handpowered palett truck showing my new design;

FIG. 2 is an elevational view thereof from an opposite side;

FIG. 3 is a front elevational view thereof;

FIG. 4 is a rear elevational view thereof;

FIG. 5 is a top plan view thereof; and,

FIG. 6 is a bottom plan view thereof.

The broken lines illustrate the environment in which the assembly is used and forms no part of the claimed design.

[56] **References Cited**

U.S. PATENT DOCUMENTS

D. 204,373 4/1966 Nichols D34/37

1 Claim, 6 Drawing Sheets

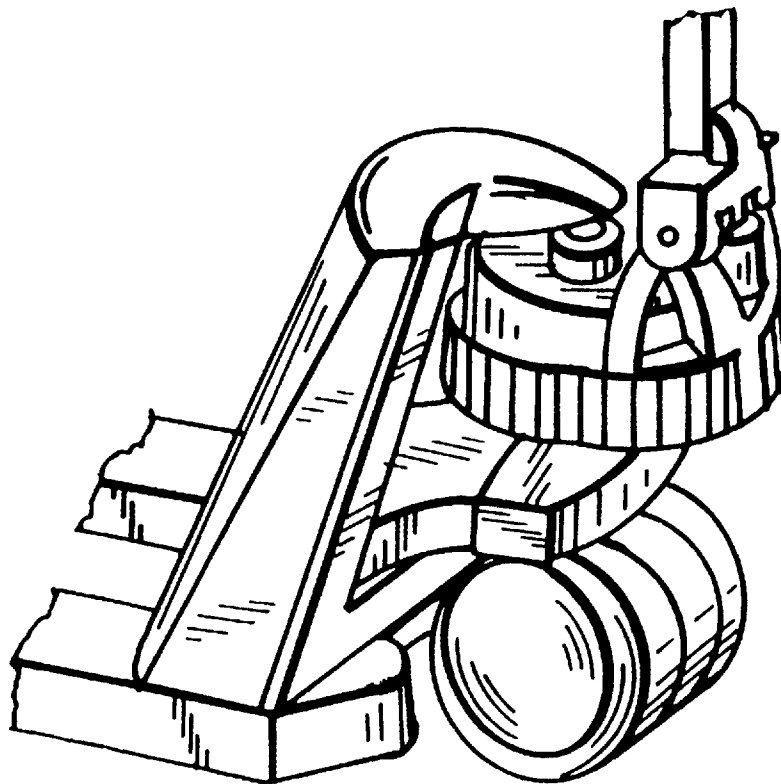

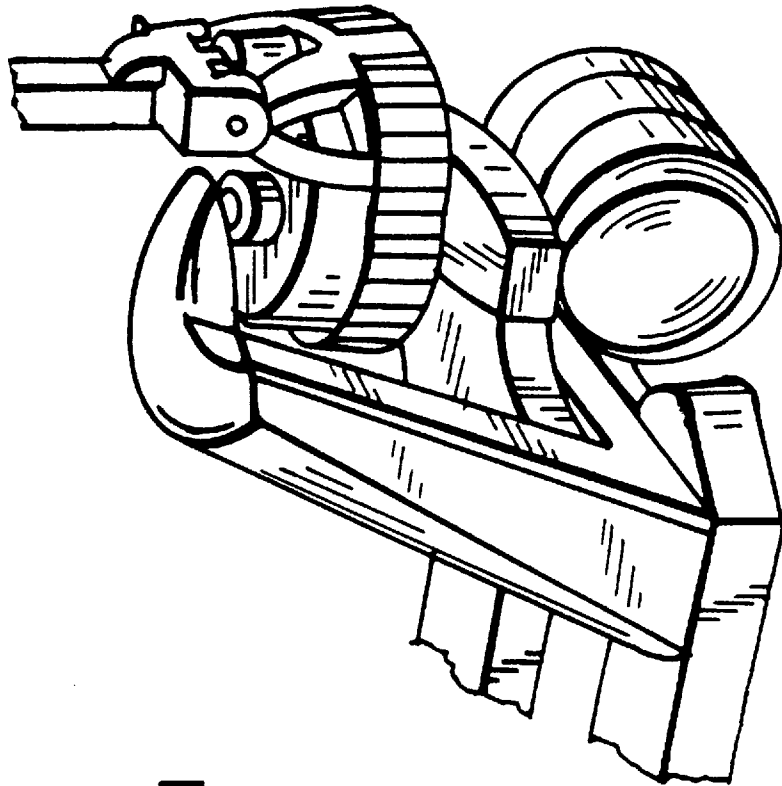
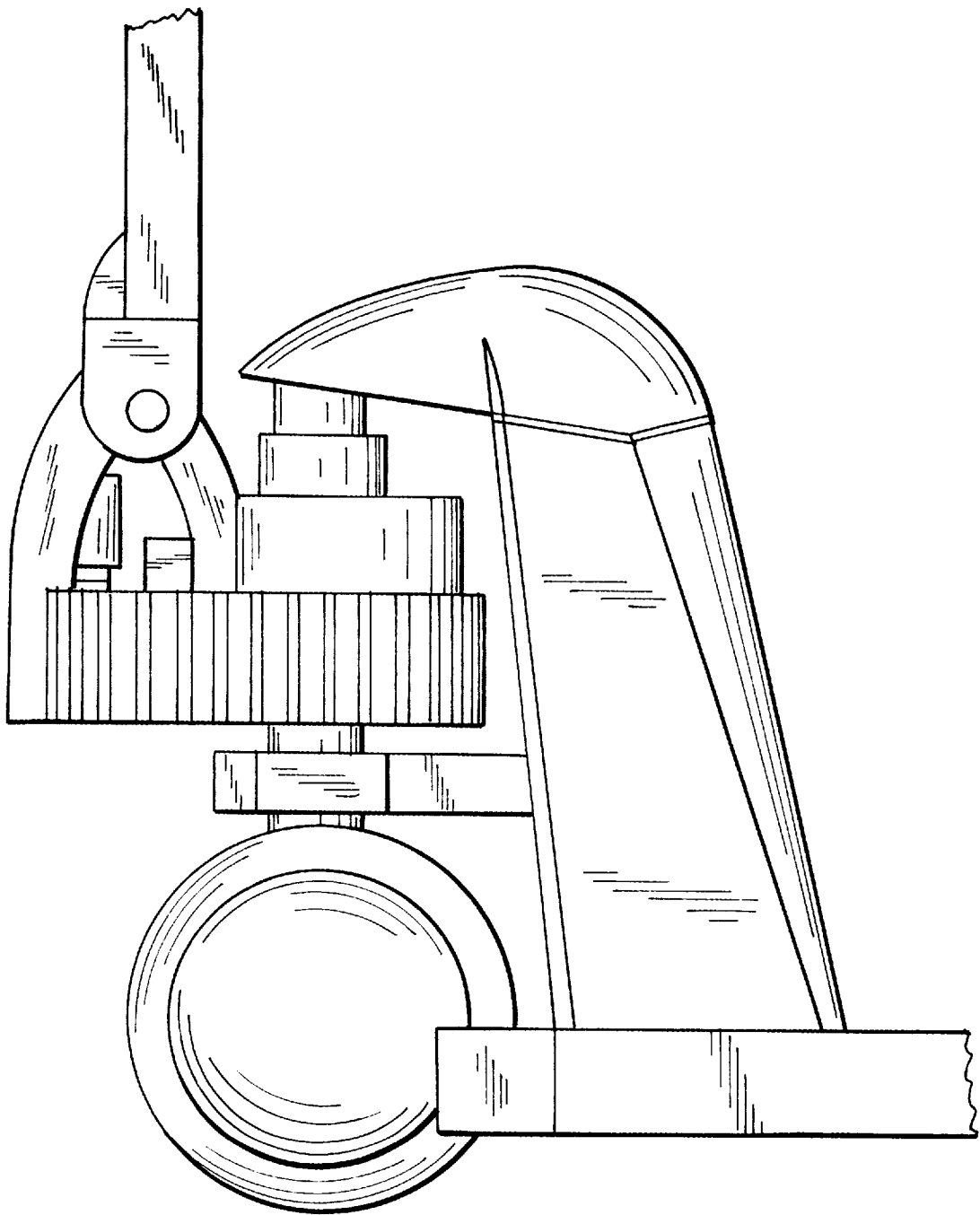

FIG. 1

FIG. 2



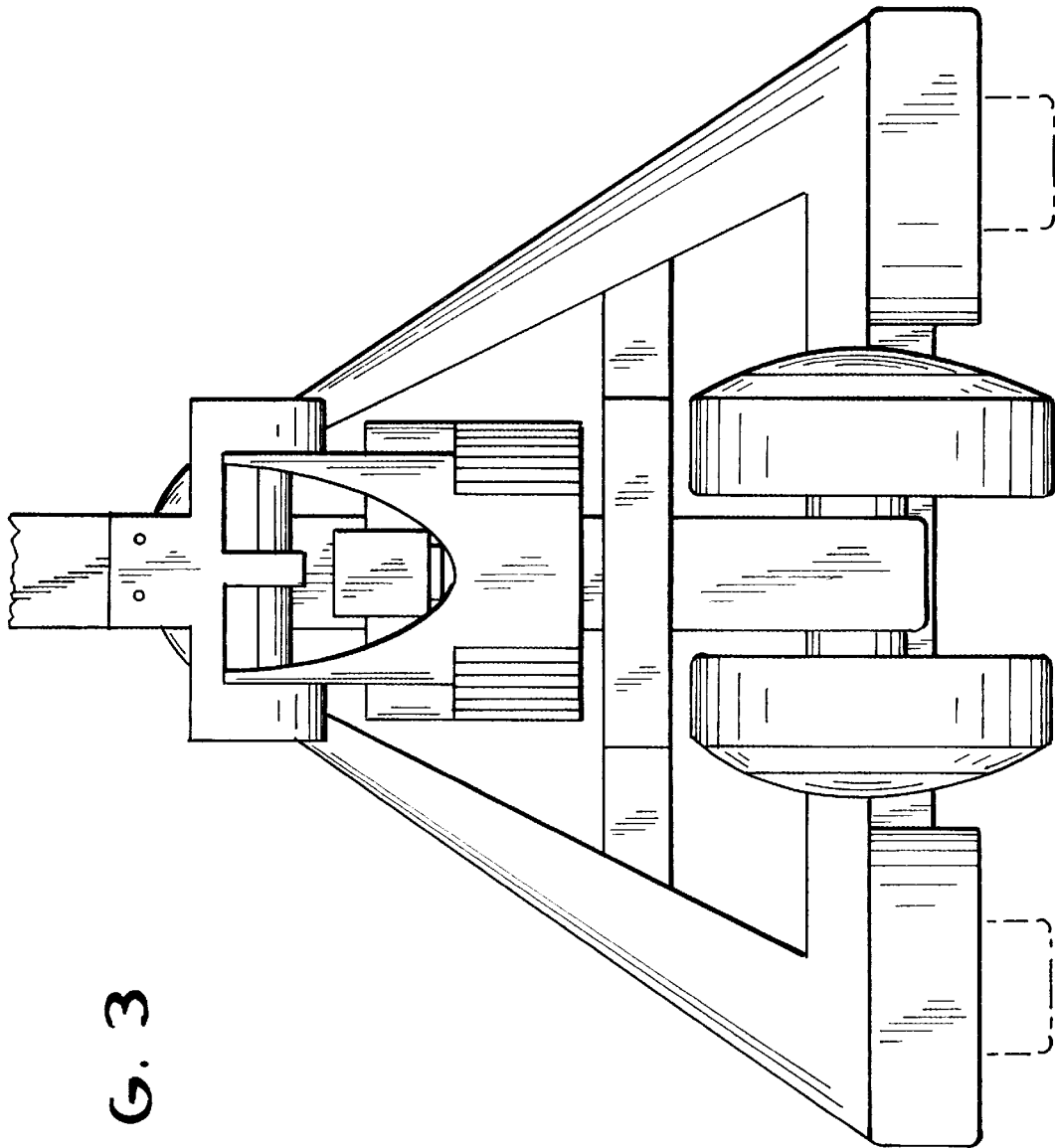

FIG. 3

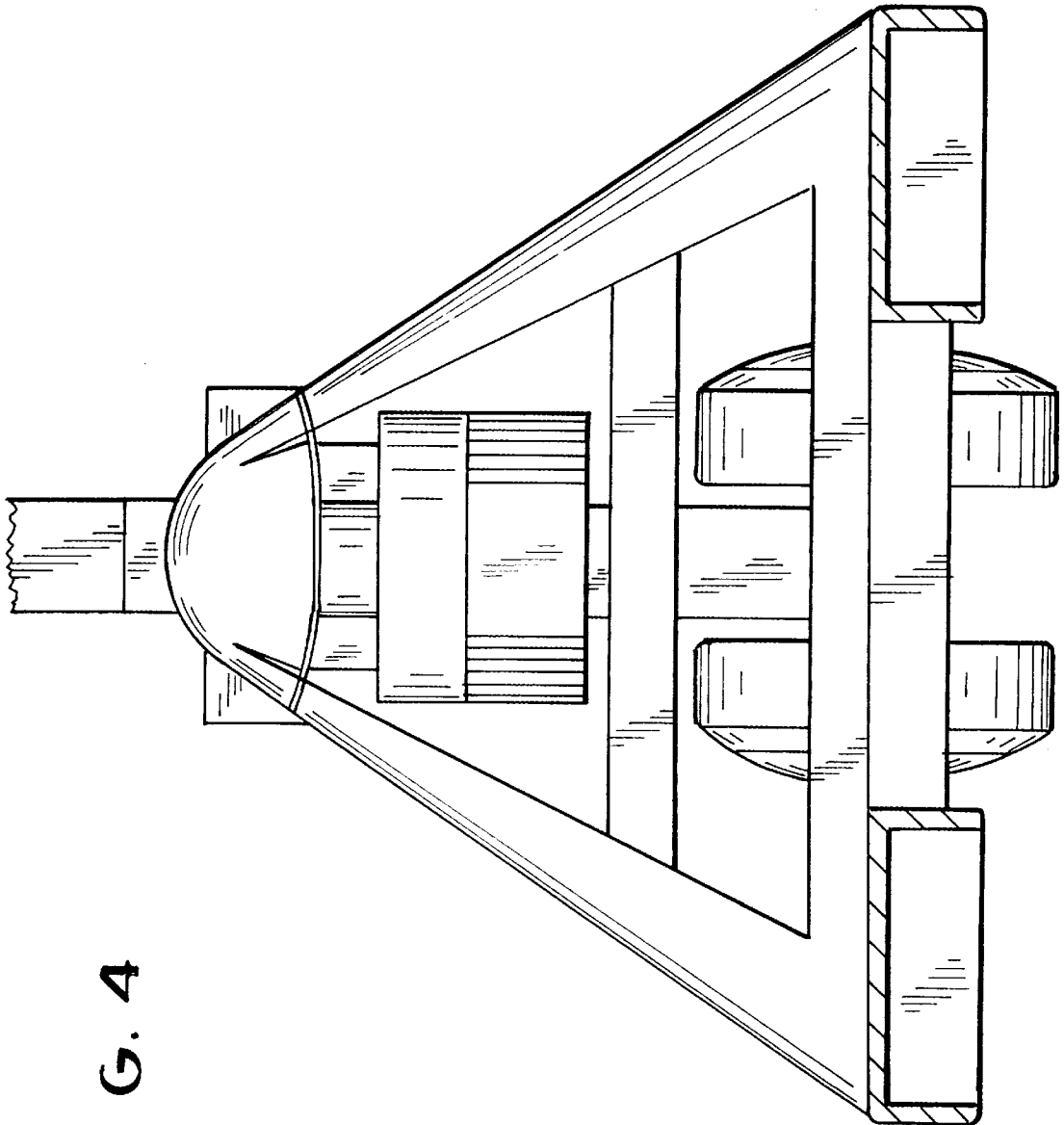

FIG. 4

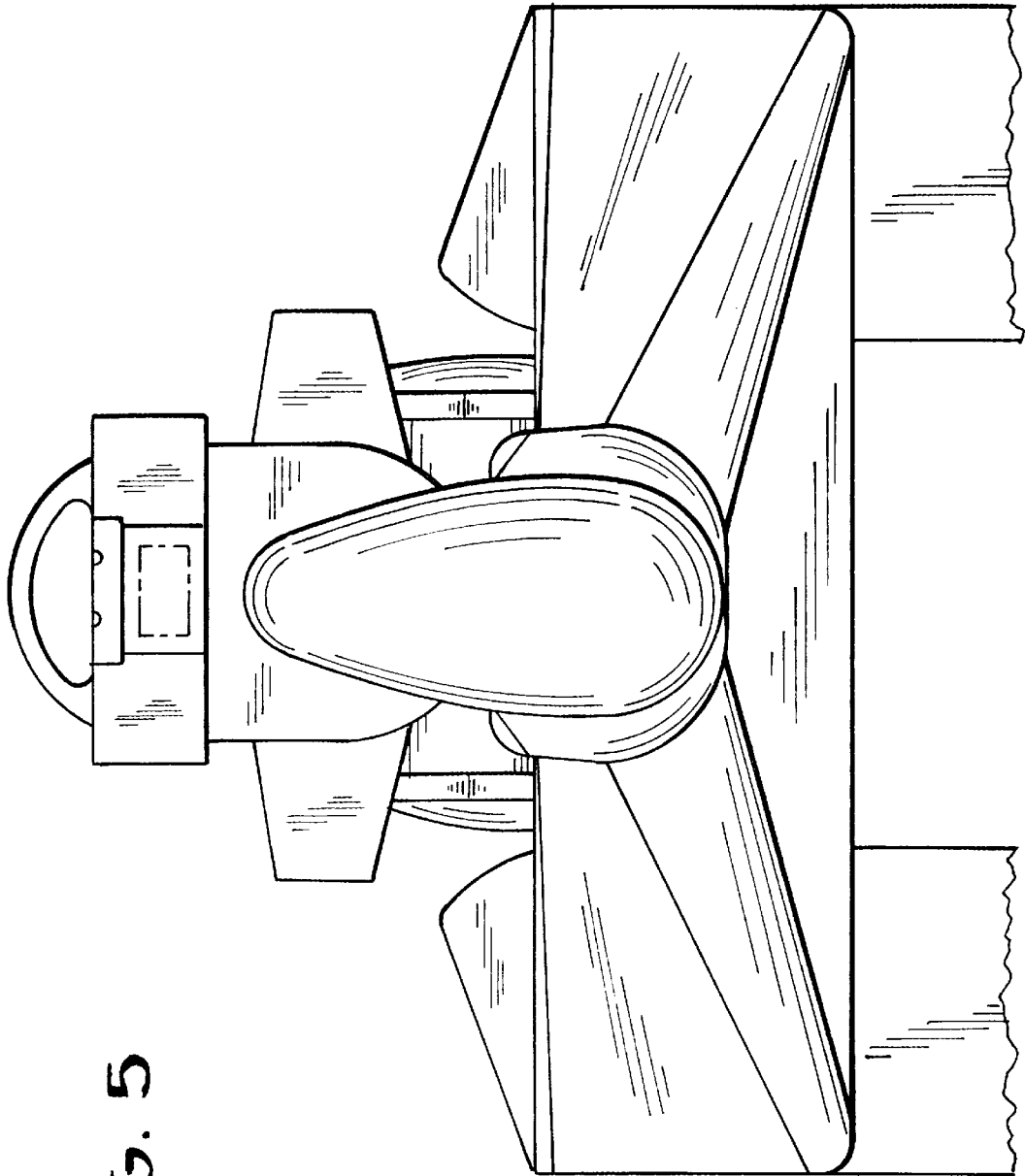

FIG. 5

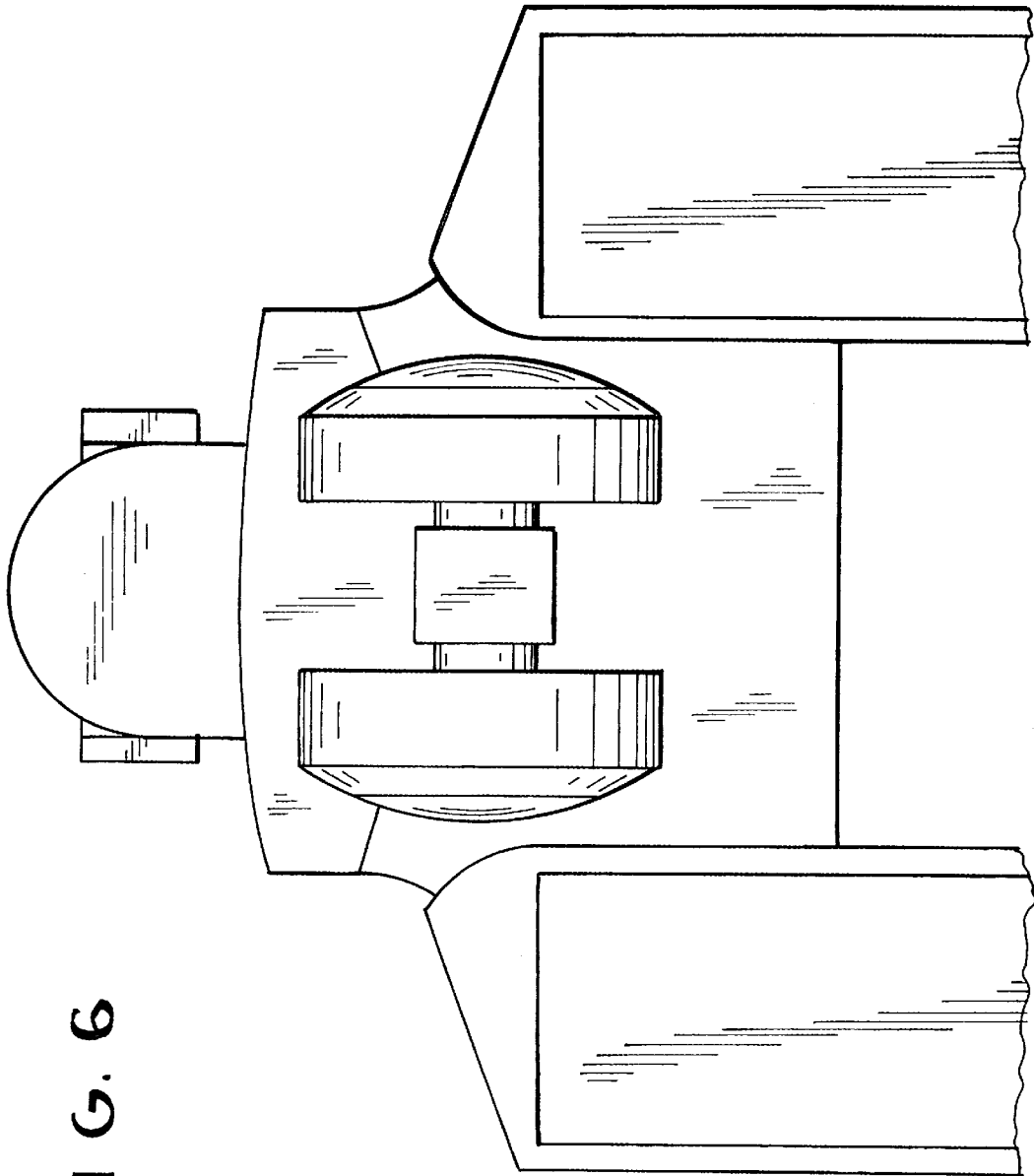

FIG. 6