

(19) World Intellectual Property Organization
International Bureau



(43) International Publication Date
6 February 2003 (06.02.2003)

PCT

(10) International Publication Number
WO 03/010878 A2

- (51) International Patent Classification⁷: **H02N**
- (21) International Application Number: PCT/US02/23672
- (22) International Filing Date: 23 July 2002 (23.07.2002)
- (25) Filing Language: English
- (26) Publication Language: English
- (30) Priority Data:

09/915,232	24 July 2001 (24.07.2001)	US
09/915,217	25 July 2001 (25.07.2001)	US
- (71) Applicant: **ONIX MICROSYSTEMS** [US/US]; 4138 Lakeside Drive, Richmond, CA 94806 (US).

(81) Designated States (*national*): AE, AG, AL, AM, AT, AU, AZ, BA, BB, BG, BR, BY, BZ, CA, CH, CN, CO, CR, CU, CZ, DE, DK, DM, DZ, EC, EE, ES, FI, GB, GD, GE, GH, GM, HR, HU, ID, IL, IN, IS, JP, KE, KG, KP, KR, KZ, LC, LK, LR, LS, LT, LU, LV, MA, MD, MG, MK, MN, MW, MX, MZ, NO, NZ, OM, PH, PL, PT, RO, RU, SD, SE, SG, SI, SK, SL, TJ, TM, TN, TR, TT, TZ, UA, UG, UZ, VN, YU, ZA, ZM, ZW.

(84) Designated States (*regional*): ARIPO patent (GH, GM, KE, LS, MW, MZ, SD, SL, SZ, TZ, UG, ZM, ZW), Eurasian patent (AM, AZ, BY, KG, KZ, MD, RU, TJ, TM), European patent (AT, BE, BG, CH, CY, CZ, DE, DK, EE, ES, FI, FR, GB, GR, IE, IT, LU, MC, NL, PT, SE, SK, TR), OAPI patent (BF, BJ, CF, CG, CI, CM, GA, GN, GQ, GW, ML, MR, NE, SN, TD, TG).

Published:
— without international search report and to be republished upon receipt of that report

For two-letter codes and other abbreviations, refer to the "Guidance Notes on Codes and Abbreviations" appearing at the beginning of each regular issue of the PCT Gazette.

- (72) Inventor: **LIN, Chuang-Chia**; 3400 Richmond Pkwy, Apt 132, San Pablo, CA 94806 (US).
- (74) Agent: **ISENBERG, Joshua**; JDI Patent, 204 Castro Lane, Fremont, CA 94539 (US).

(54) Title: MEMS ELEMENT HAVING PERPENDICULAR PORTION FORMED FROM SUBSTRATE

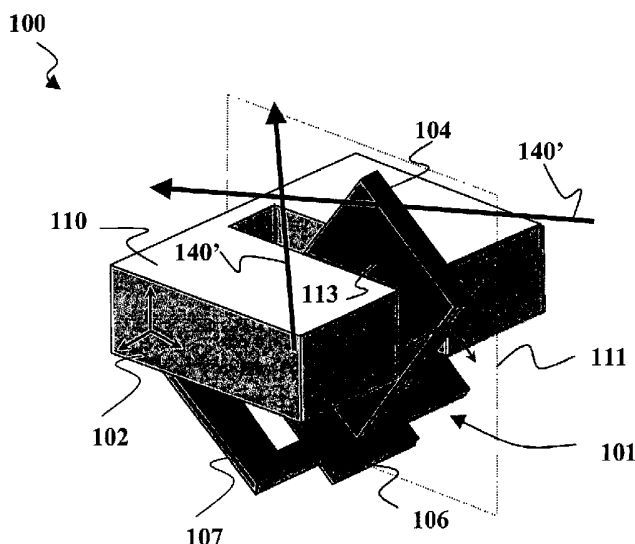

(57) Abstract: Microelectromechanical systems (MEMS) elements, optical switches and fabrication methods are described. A MEMS element comprises a crystalline moveable element moveably attached to a substrate for motion substantially perpendicular to a plane of the substrate. The moveable element includes a perpendicular portion oriented substantially perpendicular to the substrate. In at least one position, a part of the perpendicular portion projects beyond a surface of the substrate. The perpendicular portion and substrate have substantially similar crystal structures. The perpendicular portion may be formed from the substrate. An array of such structures can implement an optical switch. MEMS elements may be fabricated by forming one or more trenches in a substrate to define a perpendicular portion; attaching a moveable element to a first surface of the substrate; and removing a portion of the substrate such that at least a part of the perpendicular portion projects beyond a second surface.



WO 03/010878 A2

MEMS ELEMENT HAVING PERPENDICULAR PORTION FORMED FROM SUBSTRATE

FIELD OF THE INVENTION

5 This invention relates generally to microelectromechanical structures (MEMS). More particularly, it relates to MEMS elements.

BACKGROUND OF THE INVENTION

MEMS free-space optical switches can be categorized into two major branches: the planar matrix (2-dimensional) approach, and the beam-steering (3-dimensional) approach. The 2-
10 diemnsional approach typically involves mirrors that move between two positions (on and off). The 3-diemnsional approach requires precise “analog” control mirror position through a wide angle to steer the beam.

In a conventional 2-dimensional approach, the MEMS switching components, such as
15 rotating mirrors may be formed from a substrate using standard photolithography techniques. The mirrors are typically formed in the plane of the substrate and rotate out of plane into an “ON” or up-position to steer the beam because the light beam typically travels parallel to the substrate. Only the position accuracy at the “ON” or up-position is critical as it determine the alignment accuracy and optical loss. In the “OFF” or down-position, the mirror position can
20 be “coarsely” controlled. To align the mirrors in the up-position a two-chip approach is often used. A “top chip” is formed having openings with perpendicular sidewalls. The openings align with the mirrors formed on a “bottom chip.” A “top chip” having openings with almost perfectly perpendicular sidewalls may be formed, e.g., by etching a <110>-silicon wafer with an anisotropic etchant. When the “top” chip is properly aligned and bonded to the “bottom
25 chip,” the sidewalls of the openings can serve as reference stopping planes to fix the up-position of the mirrors. In addition, the sidewalls may also serve as electrodes to hold the mirrors in the up-position electrostatically. Unfortunately, the fabrication and alignment can be complicated, which reduces the yield of useful devices and correspondingly increases their cost.

30

It is desirable to orient the mirror in the “on” position as fabricated. Typically, the mirrors are formed as a layer on a wafer, parallel to the wafer surface. If the mirrors are “on” at this

position, one needs to form an out-of-plane array unless many wafers are stacked. It is very difficult to build such an array. Therefore, the solution is to build mirror plates oriented perpendicular to the wafer surface. One approach to making mirrors perpendicular to the wafer surface is to fold polysilicon mirrors out-of-plane. In this approach, the mirrors are formed in-plane and may be folded and latched out-of-plane by hand using a probe. This is extremely labor intensive and the accuracy is questionable as it relies on a mechanical clamp or latch to fix the mirror in the on position. Alternatively, a micro-actuator may be used to fold the mirrors out of plane. However, the space required for a capable actuator is often somewhat larger than the mirror. Consequently, the device density, an important factor, is severely compromised.

An article by Cornel Marxer et al., titled "Vertical Mirrors Fabricated by Deep Reactive Ion Etching for Fiber-Optic Switching Applications" published in the Journal of Microelectromechanical Systems, Vol. 6, No. 3, September 1997, describes the fabrication of a vertically oriented MEMS mirror from a single crystal substrate. The electrostatically actuated MEMS mirror slides horizontally, i.e., parallel to the plane of the substrate, to implement a 2X2 crossbar switch. Two pairs of optical fibers are positioned in a cross (+) shaped configuration with the MEMS mirror located at the intersection of the cross. In a "cross" state, the MEMS mirror is retracted from in between the fibers. In the "cross" state optical signals may traverse the space between the fibers in a straight path from one fiber to a directly opposing fiber. In an "add/drop" state, the mirror is interposed between the fibers to deflect optical signals by 90° from one fiber to a perpendicularly opposing fiber. Unfortunately, the switch of Marxer et al. cannot be readily scaled up to implement switches having large planar arrays of mirrors. Specifically the actuator used to move the mirror occupies space that limits the pitch or minimum spacing between mirrors.

Thus, there is a need in the art, for an optical switch having MEMS elements that overcomes the above disadvantages and a corresponding method of making it.

30

SUMMARY OF THE INVENTION

The disadvantages associated with the prior art are overcome by embodiments of the present invention directed to a microelectromechanical systems (MEMS) element. According an

embodiment of the invention, the MEMS element comprises a crystalline substrate having a crystal structure characterized by two or more substrate crystal axes. A moveable element is moveably attached to the substrate. The moveable element includes a perpendicular portion oriented substantially perpendicular to a plane of the substrate. The perpendicular portion of the moveable element has a crystal structure characterized by one or more moveable element crystal axes. The crystal structure of the perpendicular portion of the moveable element is substantially the same as the crystal structure of the substrate. When the moveable element is in at least one position, two or more of the moveable element crystal axes are oriented substantially parallel to two or more corresponding substrate crystal axes. In at least one position, a part of a perpendicular portion of the moveable element projects beyond a surface of the substrate. The moveable element may be retained by a latch.

In accordance with another embodiment of the present invention, A MEMS element may comprise a substrate and a moveable element. The moveable element is moveably attached to the substrate for motion substantially constrained to a plane oriented substantially perpendicular to a plane of the substrate. The moveable element has a perpendicular portion that is formed from the material of the substrate. The perpendicular portion is formed substantially perpendicular to the substrate. In at least one position, a part of a perpendicular portion of the moveable element projects beyond a surface of the substrate.

In accordance with another embodiment of the invention, an optical switch may comprise a crystalline substrate and one or more moveable elements moveably attached to the substrate. The substrate has a crystal structure characterized by two or more substrate crystal axes. Each moveable element includes a perpendicular portion oriented substantially perpendicular to a plane of the substrate. The perpendicular portion of each moveable element has a crystal structure characterized by one or more moveable element crystal axes. The crystal structure of each perpendicular portion is substantially the same as the crystal structure of the substrate. When a given moveable element is in at least one position, two or more of the moveable element crystal axes for the given element are oriented substantially parallel to two or more corresponding substrate crystal axes. In at least one position, a part of a perpendicular portion of each moveable element projects beyond a surface of the substrate.

Another embodiment of the present invention provides a method for making a microelectromechanical systems (MEMS) element. The method comprises providing a

substrate; forming one or more trenches in the substrate to define a perpendicular portion of a element; and moveably attaching the moveable element to a first surface of the substrate; removing a portion of the substrate such that at least a part of the perpendicular portion projects beyond a second surface of the substrate.

- 5 The various embodiments of the present invention provide for a MEMS elements that are robust, reliable and may be densely packed. MEMS elements according to embodiments of the present invention exhibit a simple design that does not require a lengthy fabrication process. The design assures high yield and improved device performance. Fabrication turnaround time can be also reduced to improve throughput.

10

BRIEF DESCRIPTION OF THE DRAWINGS

The teachings of the present invention can be readily understood by considering the following detailed description in conjunction with the accompanying drawings, in which:

- 15 FIG. **1A** is an isometric schematic diagram showing a backside view of a MEMS element according a first embodiment of the invention;

FIG. **1B** is an isometric schematic diagram showing a frontside view of the MEMS element of FIG. **1A** where a moveable element in a first position;

FIG. **1C** is an isometric schematic diagram showing another frontside view of the MEMS element of FIG. **1A** where the moveable element in a second position;

- 20 FIGS. **1D-1G** depict schematic diagrams of different possible shapes for a portion of the moveable element;

FIGS. **1H-1L** depict schematic diagrams of different actuation schemes for the moveable element;

FIGS. **1M-1P** depict schematic diagrams of a MEMS element having a latch;

- 25 FIG. **2** is an isometric schematic diagram of an optical switch according to a second embodiment of the invention;

FIG. **3** depicts a series of cross sectional diagrams illustrating a method of fabricating a MEMS element according to a third embodiment of the invention;

FIG. 4 depicts a series of cross-sectional schematic diagrams illustrating a method of fabricating a MEMS element according to a first alternative version of the third embodiment of the invention; and

DESCRIPTION OF THE SPECIFIC EMBODIMENTS

5 Although the following detailed description contains many specific details for the purposes of illustration, anyone of ordinary skill in the art will appreciate that many variations and alterations to the following details are within the scope of the invention. Accordingly, the exemplary embodiments of the invention described below are set forth without any loss of generality to, and without imposing limitations upon, the claimed invention.

10 A novel MEMS element has a vertical plate that can be precisely clamped. The plate may be made free of release holes that are common to MEMS mirrors. The plate may be made optically flat, and can move or rotate into a substrate. Also, the MEMS element may be made without requiring long slender hinges, a typical reliability culprit. Another common issue
15 such MEMS can be easily converted into a planar optical switch fabric for directing optical beams in a communications network.

This design may be realized by forming the plate out of a single crystal substrate, e.g., <110> silicon with anisotropic etchant. The plate is oriented substantially perpendicular to a plane
20 of the substrate. The plate is attached to a clamp plate to form a T-beam. When clamped to the substrate, the mirror is at ON position and the clamp plate fixes its angle. This angle will be repeatable from mirror to mirror because all mirrors may be formed by etching the same crystal. As a result, each plate has the same crystal structure as the substrate. When the plate is in the ON position, the crystal axes of the plate are substantially aligned with the crystal
25 axes of the substrate.

An example of a MEMS element **100** according to a first embodiment of the invention is depicted in FIGs. **1A-1C**. The MEMS element **100** generally includes a substrate **102** and a moveable element **101**. By way of example, the substrate **102** may be a crystalline substrate
30 having a crystal structure characterized by substrate crystal axes **121**, **122**, **123**. An example of a suitable single crystalline substrate is silicon. The moveable element **101** is moveably attached to a first surface **108** of the substrate **102**; e.g., by a clamping plate **106** and one or

more flexures **107**. The moveable element **101** may be disposed within a slot **105** in the substrate **102** for movement with respect to the substrate **102**. The moveable element **101** includes a perpendicular portion **104** that is attached to the clamping plate **106**. The perpendicular portion **104** projects partly beyond a second surface **110** of the substrate **102**.
5 The perpendicular portion **104** is oriented substantially perpendicular to a plane of the substrate **102**. As used herein, the plane of the substrate **102** may be regarded as any plane parallel to the a surface of the substrate **102**, e.g. a plane parallel to the first surface **108** or the second surface **110**. The perpendicular portion **104** has a crystal structure characterized by moveable element crystal axes **131**, **132**, **133**. The perpendicular portion **104** may be formed
10 from the substrate **102** such that the crystal structure of the perpendicular portion **104** of the moveable element **101** is substantially the same as the crystal structure of the substrate **102**.

The moveable element **101** is moveable with respect to the substrate **101** between a first position and a second position. In the embodiment depicted in FIGs. **1A-1C**, the motion of
15 the moveable element is substantially constrained to motion in a plane **111** that is oriented perpendicular to the plane of the substrate **102**. The moveable element may move between the first and second positions by rotation in the plane **111**, by translation in the plane **111**, or by some combination of rotation and translation within the plane **111**. In the first position, depicted in FIG. **1B**, the moveable portion intercepts the path of one or more optical signals
20 **140**. A light-deflecting component **113** of the perpendicular portion **104** of the moveable element **101** deflects the optical signals **140**. By way of example, the light-deflecting component **113** may be a simple plane reflecting (or partially reflecting) coating on the sides of the perpendicular portion **104**. In the example shown in FIGs. **1A-1C**, the reflective coating covers both sides of the perpendicular portion **104** so that the moveable element **101**
25 may reflect optical signals **140** that travel in two different directions. Alternatively, the light-deflecting component may be curved reflecting (or partially reflecting) surface, prismatic reflector, refractive element, prism, lens, waveguide, diffractive element, e.g. fresnel lens, a dichroic coated surface for wavelength specific and bandpass selectivity, or some combination of these. When the moveable element **101** is in the first position, two or more of
30 the moveable element crystal axes, e.g. axes **131**, **132**, **133** are oriented substantially parallel to two or more corresponding substrate crystal axes, e.g., axes **121**, **122**, **123**. In the second position, depicted in FIG. **1C**, the moveable element **101** does not intercept one or more optical signals **140'**. In the example depicted in FIGs. **1A-1C**, the movable element **101** rotates and translates between the first and second positions. A slot **105** in the substrate **102**

receives the perpendicular portion **104** and permits rotation relative to the substrate **102**. Alternatively, the moveable element **101** may translate between the first and second positions. Such translation may be either parallel to the plane of the substrate **102** or perpendicular to the plane of the substrate **102**. Note that independent of whether the
5 movable element **101** is in the first position, the second position, or some intermediate position, the perpendicular portion **104** always remains substantially perpendicular to the plane of the substrate **102**.

The perpendicular portion of the moveable element **101** may have any suitable shape. FIGs. **1D-1G** depict examples of possible shapes. FIG. **1D** depicts a perpendicular portion **104D**
10 having a substantially rectangular shape. FIG. **1E** depicts a perpendicular portion **104E** having a substantially rectangular shape with one or more clipped corners. The corners may be clipped e.g., using an axis-selective etching process. FIG. **1F** depicts a perpendicular portion **104F** having a substantially rectangular shape having arcuate sections removed from
15 one or more corners. The arcuate sections may be formed, e.g. by an isotropic etch process. FIG. **1G** depicts a perpendicular portion **104G** having a substantially rectangular shape with one or more rounded corners. The shapes of the perpendicular portions depicted in FIGs. **1E**, **1F** and **1G** reduce the angular displacement of the respective perpendicular portions **104E**, **104F** and **104G** to translate between the first and second positions.

20

Although MEMS elements of the types depicted above may be used in optical switching systems, the present invention is in no way limited to such applications. MEMS elements of the types described herein may be used in biomedical applications, for example, in microvalves that require precise positioning. Furthermore, such MEMS elements may find
25 application in micro-relays, passive radiofrequency (RF) devices such as tunable capacitors and the like.

There are many methods to actuate the moveable element **101** with the essential goal of pulling the perpendicular portion **104** into the substrate **102** by moving it with respect to the
30 plane of the substrate **102**. A magnetic material may be deposited onto the clamping plate **106** to allow the moveable element **101** to be driven by external magnetic field. Alternatively, another substrate, with electrodes, may be attached to the substrate **102**. A voltage applied between the electrodes and the clamping plate **106** may produce an electrostatic force that pulls the moveable element. These two methods can use a mechanical

restoring torque generated by a torsion hinge as the hinge **107** such that only one-way actuation is required. However, the rotation angle may be made much smaller than with mirrors formed in the plane of the substrate. Therefore, a stiffer and more robust torsion hinge may be used, which improves device reliability and manufacturability.

5

The actuation mechanism may be incorporated into the flexures **107**. For example, the moveable element **101** may be actuated with a pre-stressed flexure such as a thermal bimorph actuator or electrostatic actuator. FIGs. **1H-1I** depict schematic diagrams that illustrate an example of a moveable element **101H** that utilizes pre-stressed flexure. The moveable
10 element **101H** generally includes a perpendicular portion **104H**, a clamping plate **106H** and a pre-stressed flexure **107H**. The pre-stressed flexure **107H** is attached at a first end **117H** to a substrate **102H**. A second end **119H** of the pre-stressed flexure **107H** is free to move. By way of example, the pre-stressed flexure **107H** may utilize a bimorph element having two materials with different residual stress. The different stress levels bend the bimorph material
15 causes the second end **119H** of the pre-stressed flexure **107H** to curl away from the substrate **102H** when the second end **119H** is released. If these two materials have different coefficients of thermal expansion, heat may be applied to the pre-stressed flexure **107H** (e.g., through a microresistive heater) to pull it and the rest of the moveable element **101H** back toward the substrate **102H**. Alternatively, the bimorph can be built such that the layer next to
20 the substrate **102H** is electrically insulative. A voltage applied between the substrate and the other layer generates an electrostatic force that pulls the moveable element **101H** back toward the substrate **102H**. In either case, the motion of the moveable element **101H** may be described as a combination of translation and rotation with respect to the substrate **102H**.

25 A variation on the pre-stressed actuator of FIGs. **1H-1I** is depicted in FIGs. **1J-1K**. In this variation, a moveable element **101J** includes a perpendicular portion **104J** attached to a clamping plate **106J** and one or more elastically deformable flexures **107J**, such as springs, serpentine flexures or polymer flexures. The pre-stressed flexures **107J** are attached to opposite ends of the clamping plate **106J** and to a first surface **108J** of the substrate **102J**.
30 This configuration of pre-stressed flexures **107J** facilitates translation of the moveable element **101H** perpendicular to the substrate **102J**. In at least one position, a part of the perpendicular portion **104J** of the moveable element **101J** projects beyond a second surface **110J** of the substrate **102J**. The moveable element **101J** may also be actuated under the influence of an electrostatic or magnetic force. An electrostatic force may be exerted by

applying an electric voltage between the clamping plate **106J** and an electrode **112J**. The electrode **112J** may be disposed on a secondary substrate **116** that is attached to the substrate **102** as shown in FIG. **1K**. A magnetic force may be exerted by applying an external magnetic field to a magnetic material (not shown) attached to the clamping plate **106J**. The secondary substrate **116** may include a recess **114** that accommodates the movement of the moveable element **101J** and the flexures **107J**.

An actuation scheme that uses torsional hinge flexures is depicted in FIG. **1L**. In this variation, a moveable element **101L** includes a perpendicular portion **104L** attached to a clamping plate **106L** and one or more torsional hinge flexures **107L**. The torsional hinge flexures **107L** are attached to opposite ends of the clamping plate **106L** and define an axis of rotation. The free ends of the torsional hinge flexures **107L** may be attached to a substrate such as the substrate **102** of FIG. **1A-1C**. The torsional hinge flexures **107L** apply a torsional, or restoring force that returns the moveable element **101L** to the second position when an actuating force is removed. However, other restoring forces may be applied to moveable element **101L** to return the flap to the second position. Such forces may be exerted on moveable element **101L** by biasing mechanisms that operate via electrostatic, pneumatic, thermal, or magnetic principals, including coils that interact with an external magnetic field, electrostatic elements, such as gap closing electrodes, piezoelectric actuators, stress bearing elements and thermal actuators. Multiple restoring forces may also used together, and the forces may operate along the same or opposing directions.

An additional variation on the first embodiment of the present invention provides a latch for retaining the moveable element in the first position. FIGs. **1M-1P** depict a MEMS element **100M** that uses such a latch. The MEMS element **100M** generally includes a substrate **102M**, a moveable element **101M** and a latch **150**. The moveable element includes a perpendicular **104M** portion attached to a clamping plate **106M**. The clamping plate **106M** is attached to a first surface **108M** of the substrate **102M** by one or more flexures **107M**. The flexures **107M** may be any of the types described above. The flexures **107M** permit the moveable element to move as shown by the curved arrows. In at least one position, a part of the perpendicular portion **104M** of the moveable element **101M** projects beyond a second surface **110M** of the substrate **102M**. In the first position, depicted in FIG. **1P**, the perpendicular element may intercept an optical signal **140M'**. In the first position the clamping plate **106M** is substantially parallel to the first surface of the substrate **102M** and the perpendicular element

104M is substantially perpendicular to a second surface **110M** of the substrate **102M**. In a second position, depicted in FIG. **1N** the perpendicular element is moved out of the path of an optical signal **140M**.

5 The latch **150** retains the moveable element **101M** in the first position. By way of example, and without loss of generality, the latch **150** may include a latch plate **152**, guides **154A**, **154B**, an actuator **156** and one or more optional springs **158A**, **158B**. The latch plate **152** slides parallel to the substrate **102M** to engage the clamping plate **106M**. The guides **154A**, **154B** constrain the motion of latch plate **152** to a lateral motion in substantially a single
10 dimension. The latch plate **152** and guides **154A**, **154B** are disposed on a raised portion **151** of the substrate **102M**. The latch plate **152** may include a stop **160** that restricts the range of the lateral motion of the latch plate **152**. By way of example, the stop **160** may be implemented as a projection **153** that engages a slot **155**. The projection **153** is attached to
15 a first end **157** or a second end **159** of the slot **155**. It should be pointed out that the implementation of the stop **160** that is depicted in FIG. **1M** is merely one example of many possible stop configurations. Consequently, the invention should not be construed as being limited to this particular configuration.

20 The actuator **156** provides a force for selectively moving the latch plate **152** into or out of engagement with the clamping plate **106M**. By way of example, the actuator **156** may be a magnetic material that interacts with a magnetic field. The actuating force may alternatively be provided by an actuator operating by electrostatic, pneumatic, piezoelectric, thermal bimorph or other principles. The optional springs **158A**, **158B** may be attached at one end to
25 the raised portion **151** to urge the latch plate **152** towards the clamping plate **106M** and force the latch plate **152** against the projection **153**. The springs **158A**, **158B** thus provide a restoring force on the latch plate **152**, such that the actuator **156** is only required to exert a force to move the latch out of engagement with the clamping plate **106M**.

30 The latch **150** is advantageous in MEMS elements that apply an actuating force to move the moveable element **101M** into the first position. The latch **150** mechanically retains the moveable element **101M** in the first position so that the actuating force may be turned off. This is particularly advantageous if the actuating force involves the use of an electromagnet. The electromagnet may be turned off, and therefore, need not consume power, while the

moveable element is retained in the first position by the latch **152**. If the flexure **107M** biases the moveable element in the second position, the electromagnet need only be turned on to move the moveable element **101M** from the second position to the first position. Thus, power consumption may be substantially reduced and the configuration moveable element **101M** may be preserved in the event of a power failure. Preserving the state of the moveable element **101M** is particularly useful where two or more moveable elements are arrayed together in a MEMS device. If each moveable element is provided with a latch, such as the latch **160**, the state of the state of the array, i.e., the set of individual states of each moveable element, may be preserved in the event of a power failure.

10

A second embodiment of present invention includes systems that incorporate two or more MEMS elements of the type described above with respect to FIGS. **1A-1C**, e.g. arranged in an array. Such an array is depicted in the form of an optical switch **200** of FIG. **2**. The optical switch **200** generally comprises a crystalline substrate **202** and an array of moveable elements **204** oriented substantially perpendicular to a plane of the substrate **202**. The moveable elements have features in common with MEMS elements the type depicted in FIGs. **1A-1C**. Specifically, each element **204** has a crystal structure characterized by one or more moveable element crystal axes. The crystal structure of each moveable element **204** is substantially the same as the crystal structure of the substrate **202**. When a given moveable element is in at least one position, two or more of the moveable element crystal axes for the given element are oriented substantially parallel to two or more corresponding substrate crystal axes.

15
20

The moveable elements **204** include light-deflecting portions that selectively couple optical signals **240** between one or more input fibers **206** and one or more output fibers **208**. In the example of the second embodiment shown in FIG. **2**, the moveable elements translate perpendicular to a plane of the substrate **202** between a first position and a second position. In the first position, part of a perpendicular portion of a given moveable element projects beyond a surface **210** of the substrate so that the moveable element **204** intercepts the optical signal **240** to deflect it. In the second position, the given moveable element translates into a slot **205** in the substrate **202** to allow the optical signal **240** to bypass without deflection. Although the moveable elements **204** depicted in the optical switch **200** of Fig. **2** translate to selectively deflect the optical signals **240**, the moveable elements may alternatively move in a manner similar to that depicted in any of FIGs. **1B-1P**.

25
30

According to a third embodiment of the invention MEMS elements, such as elements of the types depicted in FIGs. 1A-1P, may be fabricated according to an inventive process. According to the method a substrate is provided and one or more trenches are formed in the substrate to define a moveable element. The moveable element is moveably attached to a first surface of the substrate. A portion of the substrate is removed such that at least a portion of the moveable element projects beyond a second surface of the substrate.

An example of such a fabrication process is shown in the series of cross-sectional schematic diagrams of FIG. 3. The process starts at step 301 by forming a clamping plate 306 and one or more flexures 307 on a first surface 323 of a substrate 320. The substrate 320 may be a crystalline substrate characterized by a set of substrate crystal axes 322. The clamping plate 306 and flexure 307 may be formed from the same material or, alternatively, from different materials. A pattern of sacrificial material 308 may be deposited prior to forming the clamping plate 306 and flexures 307. The sacrificial material is deposited on the first surface 323 in a pattern such that the clamping plate 306 and flexures 307 are only attached to the substrate 320 at specific locations. In step 303 one or more trenches 310 are formed in the substrate to define a perpendicular portion 304 of a moveable element. The perpendicular portion 304 is attached to the substrate 320 by the clamping plate 306 and the flexure 307. It is important during step 303 to protect the perpendicular portion 304 from being etched by the etch process that forms the trenches 310 in the substrate 320. The perpendicular portion 304 and substrate 320 may be protected during this step by a suitably patterned etch-resistant mask (not shown). In step 305 a second surface 325 of the substrate 320 is etched back to expose the perpendicular portion 304. It is important during step 305 to protect the perpendicular portion from being etched by the etch process that attacks the substrate 320. Again, a suitable etch-resistant mask may be formed on the perpendicular portion 304. The perpendicular portion 304 is oriented substantially perpendicular to a plane of the substrate 320. Note that the perpendicular portion 304 is formed from the same material as the substrate and need not be rotated out of plane. Furthermore, if the substrate 320 is a crystalline substrate, the perpendicular portion 304 will be characterized by perpendicular portion crystal axes 342 that substantially align with the substrate crystal axes 322. By appropriate processing the perpendicular portion 304 may be formed with optically smooth sidewalls. The sacrificial material 308 may be removed in a final release step to provide one

or more gaps 309 between the second surface 323 and the clamping plate 306 and/or flexures 307.

A more detailed example of such a fabrication process is shown in the series of cross-sectional schematic diagrams FIG. 4. The process starts at step 401 by providing a substrate 422. The substrate has a first surface 424 and a second surface 426. The substrate 422 may be a single crystalline base material, characterized by two or more substrate crystal axes 421, 423. By way of example, the substrate 422 may be a wafer of <110> silicon. First and second etch resistant insulator material layers 428, 429 are deposited on respectively the first and second surfaces 424, 426 of the substrate 422. An example of an etch-resistant insulator material is low stress silicon nitride. Alternatively, the etch-resistant insulator material may be aluminum nitride or silicon carbide.

At step 403, the etch-resistant insulator layer 429 may be removed from the second surface 426 and a sacrificial insulator layer 430 may be deposited on the first and second surfaces of the substrate 422. It is important that the material of sacrificial insulator layer 430 be resistant to an etch process that attacks the bulk material of the substrate 422. An example of a suitable material for the sacrificial insulator layer 430 is silicon dioxide, which is resistant to a KOH etch used to etch silicon. Steps 401, 402 and 403 illustrate only one example of providing a substrate coated with one or more layers of sacrificial material. There are many other ways of achieving this without departing from the scope of the present invention.

In step 404, an etch process opens contact holes 432 through the sacrificial insulation layer 430 on the first surface 424. A second etch process may form shallow dimples 434 on the surface of the sacrificial insulation layer 430 on the first surface 424. In step 405 the sacrificial layer 430 on the second surface 426 is patterned and etched, e.g. by photolithographic process, in such a way as to leave a strip of sacrificial material 436 right below the contact holes 435. For example, if the etch-resistant insulator layer 429 is selective to the bulk etch process, it may be possible to pattern the etch-resistant insulator 429 to form the strip 436 shown in step 405.

At step 406, a conductive layer 438 is deposited over the sacrificial layer 430 on the first surface 424 of the substrate 422. The conductive layer 438 fills the contact holes 432 in the sacrificial insulator layer 430 to attach the conductive layer 432 to the etch-resistant insulator

layer 430 on the first surface 424 of the substrate 422. The conductive layer 438 also fills the dimples 434. To form the conductive layer 438, conductive material (e.g. polysilicon) may be deposited simultaneously on both the first surface 424 and the second surface 426 of the substrate 422 and the deposited conductive material may be subsequently stripped from the second surface 426. Alternatively, the conductive material may be deposited on only the sacrificial layer 430 on the first surface 424 to form the conductive layer 438. In step 407 a third etch-resistant insulator layer 440 may be deposited on the first surface 424 and a fourth etch-resistant layer 442 may be deposited on the second surface 426.

During step 408, the etch-resistant insulator layer 442 on the second surface 426 is patterned, and a through-wafer anisotropic etch forms trenches 444 in the substrate 422 to define a perpendicular portion 446 of a moveable element. At step 409 a layer of sacrificial insulating material 448 is formed on the sidewalls of the trenches 444. For example, the substrate 422 may be sent to oxidation furnace to form a layer of oxide on the sidewalls of the trenches 444. It is important that the sacrificial insulator material 448 is resistant to an etch process that etches the material of the substrate 422. At step 410, the etch-resistant insulator layers 440, 442 are removed from the first and second surfaces 424, 426 respectively. At step 411, the conductive material 438 on the first surface 424 is patterned to form a clamping plate 450. The conductive material 438 may also be patterned to form a flexure (not shown) that is attached to the clamping plate 450. An actuator may also be formed on the clamping plate 450 or other portion of the first surface 424 at this time. In step 412 the bulk material of the substrate 422 is etched from the second surface 426 to expose a portion of the perpendicular portion 446 above the second surface 426 of the substrate 422. Note that the, for the purposes of illustration, the substrate has been inverted between steps 411 and 412. The sacrificial insulating material 448 on the sidewalls and the strip of sacrificial material 436 protect the sides and end of the perpendicular portion 446 during the etch process. It is critical that the etch process be selective in that it removes the bulk material from substrate 422 but does not attack the sacrificial insulator material in the layer 448 on the sidewalls or the strip 436. For example, where the substrate 422 is silicon and the sacrificial material is silicon oxide, a wet etch with KOH may be used. Alternatively, a dry etch with XeF₂ may be used.

At step 413 the remaining sacrificial insulator material is removed, e.g., the layers 448 on the sidewalls of the moveable element, the strip of sacrificial material 436 on the end of the

perpendicular portion 446 and any remaining portions of the sacrificial layer 430 on the first surface 424 of the substrate 422. The perpendicular portion 446 and the clamping plate 450 form a moveable element 415. With the removal of the sacrificial layer 430, the moveable element 415 is released and free to move. The perpendicular portion 446 is attached to the substrate 422 by the conductive material 450. The filled dimples 434 reduce the contact area between the conductive material and the first surface 424 of the substrate 422, which may help to reduce stiction. Because the perpendicular portion 446 is formed from the substrate 422, the perpendicular portion 446 has substantially the same crystal structure as the substrate 422. In particular the perpendicular portion 446 has crystal axes 445, 447 that align with substrate crystal axes 421, 423 when the moveable element is in the orientation shown.

A few optional steps may be added to complete the actuator. The actual process depends on the design but can be as simple as a metal deposition/lift-off to define contact pads. For example, a light-deflective element 452 may be formed on the perpendicular portion 446. Such a light-deflective element may be any of the types described above. In a particular example, the light-deflective element 452 may be a reflective coating, e.g., gold sputter deposited on the perpendicular portion 446. The substrate 422, with the perpendicular portion 446 may be bonded to a handle wafer 454 as shown in step 414. The handle wafer 454 can be formed using transparent glass wafers with ITO electrodes to improve ease of inspection.

While the above is a complete description of the preferred embodiment of the present invention, it is possible to use various alternatives, modifications and equivalents. For example, a fabrication process similar to that shown in Figs 3 and 4 but involving the usage of SOI wafers can be easily implemented. Therefore, the scope of the present invention should be determined not with reference to the above description but should, instead, be determined with reference to the appended claims, along with their full scope of equivalents. The appended claims are not to be interpreted as including means-plus-function limitations, unless such a limitation is explicitly recited in a given claim using the phrase "means for."

30

WHAT IS CLAIMED IS:

- 1 1. A microelectromechanical systems (MEMS) element, comprising:
2 a crystalline substrate having a crystal structure characterized by two or more
3 substrate crystal axes;
4 a moveable element moveably attached to the substrate;
5 wherein the moveable element includes a perpendicular portion oriented substantially
6 perpendicular to a plane of the substrate;
7 wherein the perpendicular portion of the moveable element has a crystal structure
8 characterized by one or more moveable element crystal axes;
9 wherein the crystal structure of the perpendicular portion of the moveable element is
10 substantially the same as the crystal structure of the substrate;
11 wherein, when the moveable element is in at least one position, a part of the
12 perpendicular portion projects beyond a surface of the substrate;
13 wherein, when the moveable element is in at least one position, two or more of the
14 moveable element crystal axes are oriented substantially parallel to two or more
15 corresponding substrate crystal axes.
- 1 2. The MEMS element of claim 1 wherein the moveable element is substantially
2 restricted to movement in a plane substantially perpendicular to the plane of
3 the substrate.
- 1 3. The MEMS element of claim 2 wherein moveable element may rotate about a
2 rotation axis.
- 1 4. The MEMS element of claim 3 wherein the rotation axis is substantially
2 parallel to the plane of the substrate.
- 1 5. The MEMS element of claim 4 wherein rotation axis is oriented substantially
2 perpendicular to a plane of the moveable element.
- 1 6. The MEMS element of claim 1 wherein the perpendicular portion of the
2 moveable element is formed from a portion of the crystalline substrate.

- 1 7. The MEMS element of claim 6 wherein the moveable element is formed from
2 the substrate.
- 1 8. The MEMS element of claim 1 wherein the moveable element includes a
2 light-deflecting component.
- 1 9. The MEMS element of claim 8 wherein the light-deflecting portion includes a
2 reflective coating.
- 1 10. The MEMS element of claim 9 wherein the light deflecting is disposed on two
2 sides of the perpendicular portion.
- 1 11. The MEMS element of claim 1 wherein the moveable element is moveably
2 attached to the substrate at first surface of the substrate.
- 1 12. The MEMS element of claim 11 wherein the substrate includes a second
2 surface; and
3 wherein the second surface of the substrate is substantially parallel to the first
4 surface of the substrate.
- 1 13. The MEMS element of claim 1:
2 wherein the movable element includes a clamping plate attached to an edge of
3 the perpendicular portion of the moveable element;
4 wherein the clamping plate is oriented substantially perpendicular to the
5 moveable element;
6 wherein the clamping plate is oriented substantially parallel to a first surface
7 of the substrate;
8 wherein, when the moveable element is in at least one position, the clamping
9 plate engages the first surface of the substrate.
- 1 14. The MEMS element of claim 1, further comprising:
2 an actuator coupled to the moveable element.
- 1 15. The MEMS element of claim 14 wherein the actuator includes a magnetic
2 material disposed on the moving element
- 1 16. The MEMS element of claim 14 wherein the actuator includes an electrode.

- 1 17. The MEMS element of claim 14 wherein the actuator is thermally or
2 electrostatically actuated.
- 1 18. The MEMS element of claim 14 wherein the actuator may move the moveable
2 element between the at least one position in which the perpendicular portion
3 projects beyond the surface of the substrate and a second position.
- 1 19. The MEMS element of claim 14 further comprising a biasing element coupled
2 to the moveable element.
- 1 20. The MEMS element of claim 1 further comprising a latch coupled to the
2 substrate for retaining the moveable element in at least one position.
- 1 21. The MEMS element of claim 20 wherein the latch includes a latch plate and
2 one or more guides for restricting a range of motion of the latch plate.
- 1 22. The MEMS element of claim 21 further comprising a stop for restricting a
2 motion of the latch.
- 1 23. The MEMS device of claim 21 further comprising an actuator coupled to the
2 latch plate.
- 1 24. A MEMS element comprising:
2 a substrate;
3 a moveable element moveable attached to the substrate for motion substantially
4 constrained to a plane oriented substantially perpendicular to a plane of the substrate;
5 wherein the moveable element has a perpendicular portion;
6 wherein the perpendicular portion is formed from the material of the substrate; and
7 wherein the perpendicular portion is formed substantially perpendicular portion to the
8 substrate;
9 wherein, when the moveable element is in at least one position, a part of the
10 perpendicular portion projects beyond a surface of the substrate.
- 1 25. The MEMS element of claim 24 wherein the moveable element is attached to
2 a surface of the substrate that is opposite the surface beyond which the
3 perpendicular portion may project.

- 1 26. The MEMS element of claim 24 wherein the perpendicular portion includes a
2 light-deflecting component.
- 1 27. The MEMS element of claim 26 wherein the light-deflecting component is a
2 reflective coating.
- 1 28. The MEMS element of claim 27 wherein the reflective coating is disposed on
2 two surfaces of the perpendicular portion.
- 3 29. The MEMS element of claim 24, further comprising a clamping plate attached
4 to the perpendicular portion.
- 1 30. The MEMS element of claim 29, further comprising a flexure attached to the
2 clamping plate and the substrate.
- 1 31. The MEMS element of claim 30 wherein the flexure is a torsional flexure.
- 1 32. The MEMS element of claim 30 wherein the flexure is a pre-stressed flexure,
- 1 33. The MEMS element of claim 32 wherein the pre-stressed flexure is a thermal
2 bimorph flexure.
- 1 34. The MEMS element of claim 32 wherein the pre-stressed flexure is an
2 electrostatic zip actuator.
- 1 35. An optical switch comprising:
2 a crystalline substrate having a crystal structure characterized by two or more
3 substrate crystal axes;
4 one or more moveable elements moveably attached to the substrate;
5 wherein each moveable element includes a perpendicular portion oriented
6 substantially perpendicular to a plane of the substrate;
7 wherein the perpendicular portion of each moveable element has a crystal structure
8 characterized by one or more moveable element crystal axes;
9 wherein the crystal structure of each perpendicular portion is substantially the same as
10 the crystal structure of the substrate;

11 wherein, when a given moveable element is in at least one position, two or more of
12 the moveable element crystal axes for the given element are oriented substantially
13 parallel to two or more corresponding substrate crystal axes;
14 wherein, when a given moveable element is in at least one position, a part of the
15 perpendicular portion projects beyond a surface of the substrate;

1 36. The optical switch of claim 35 wherein one or more of the moveable elements
2 include a light deflecting portion.

1 37. The optical switch of claim 35, further comprising one or more optical fibers
2 optically aligned with one or more of the optical elements.

1 38. The optical switch of claim 35 wherein each moveable element is formed from
2 a portion of the crystalline substrate.

1 39. The optical switch of claim 35 wherein one or more of the moveable elements
2 may rotate about a rotation axis.

1 40. The optical switch of claim 39 wherein the rotation axis is substantially
2 parallel to the plane of the substrate.

1 41. The optical switch of claim 40 wherein the rotation axis is substantially
2 perpendicular to a plane of at least one of the moveable elements.

1 42. The optical switch of claim 35 wherein one or more of the moveable elements
2 may translate in a direction substantially perpendicular to a plane of the
3 substrate.

1 43. A method for making a microelectromechanical systems (MEMS) element
2 comprising:
3 providing a substrate;
4 forming one or more trenches in the substrate to define a perpendicular portion of a
5 element; and
6 moveably attaching the moveable element to a first surface of the substrate;
7 removing a portion of the substrate such that at least a part of the perpendicular
8 portion projects beyond a second surface of the substrate.

- 1 44. A MEMS element fabricated by the method of claim 43.
- 1 45. The method of claim 43 wherein the substrate is a single crystal substrate.
- 1 46. The method of claim 43 wherein the substrate is a silicon on insulator (SOI)
2 substrate.
- 1 47. The method of claim 43 wherein the removing step includes protecting the
2 perpendicular portion from attack by a process that removes substrate
3 material.
- 1 48. The method of claim 47 wherein the removing step includes protecting one or
2 more sidewalls of the trenches from attack by a process that removes substrate
3 material.

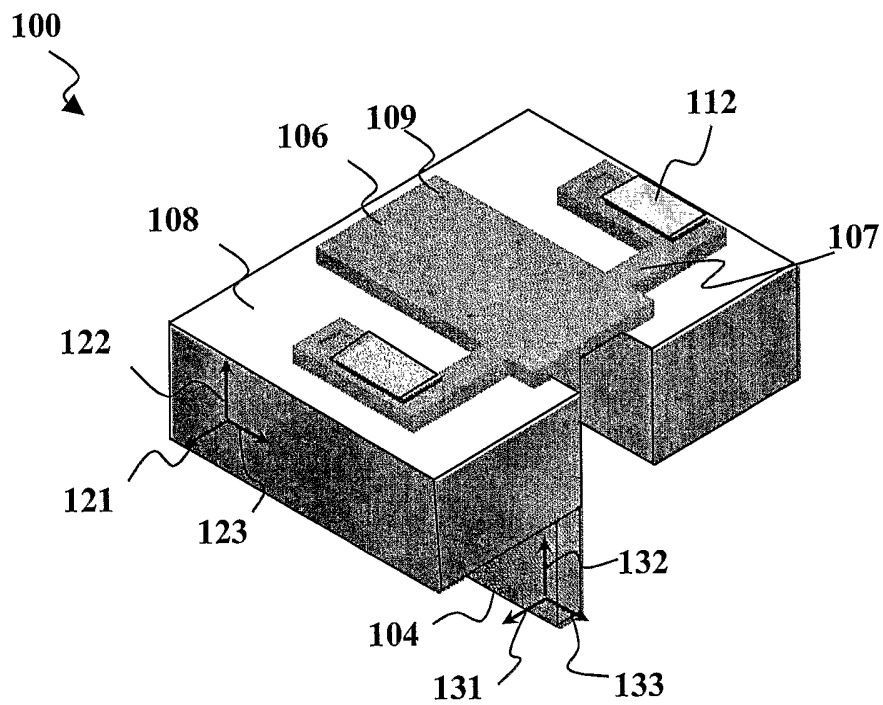

FIG. 1A

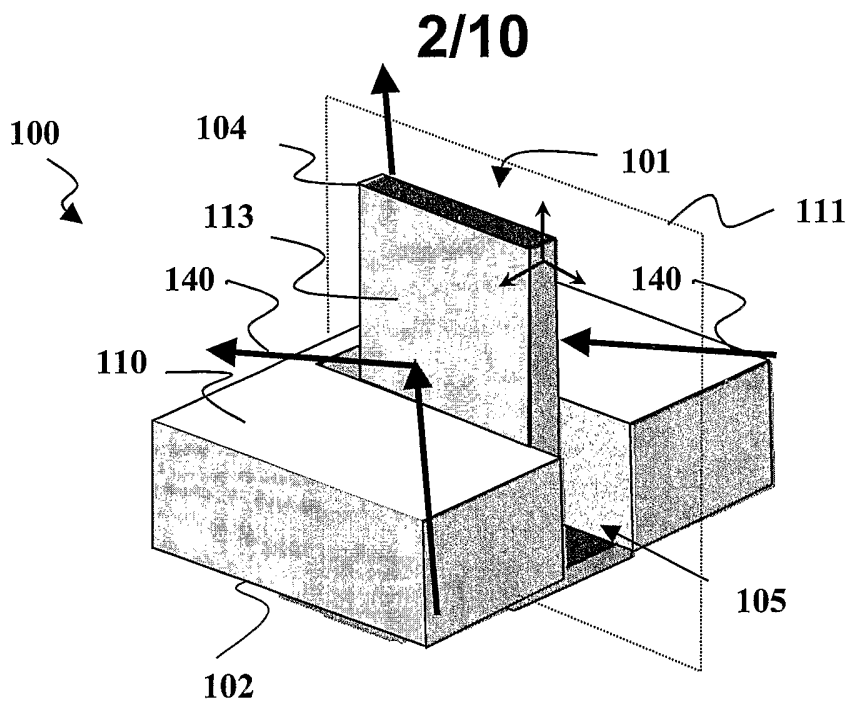

FIG. 1B

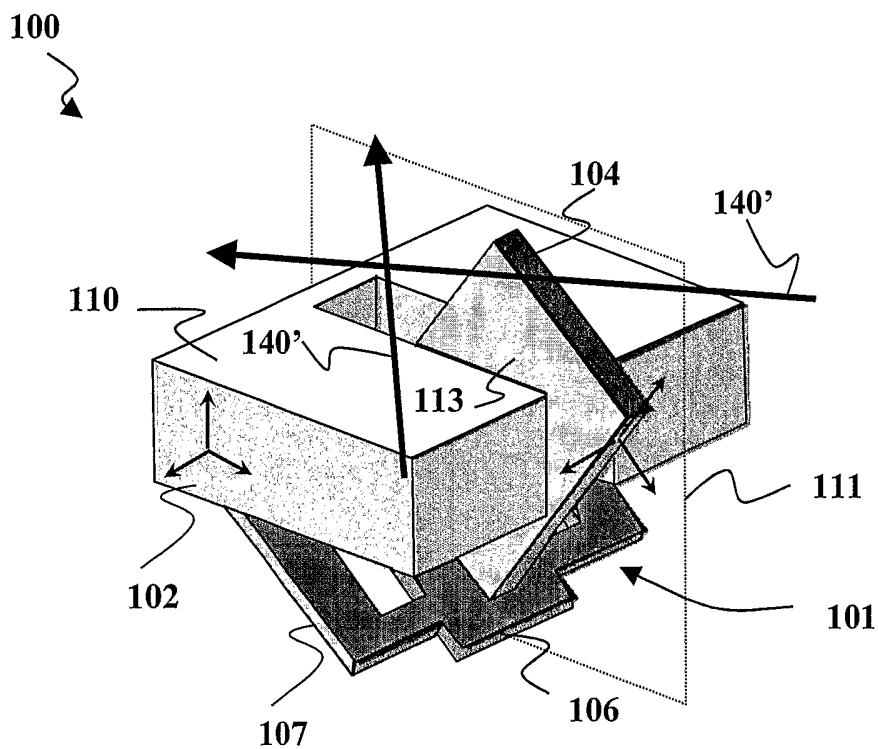

FIG. 1C

3/10

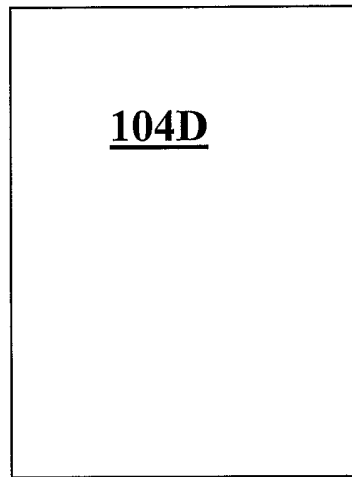

FIG. 1D

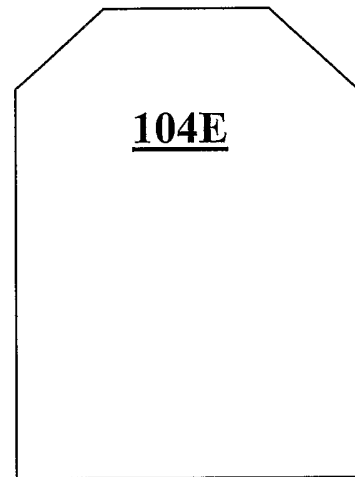

FIG. 1E

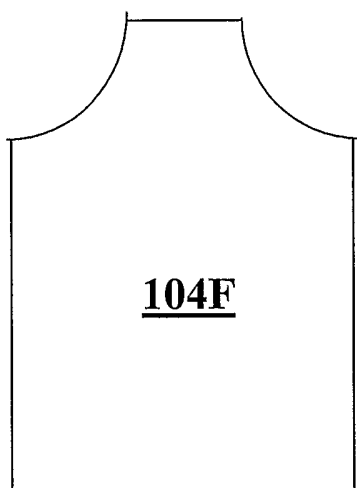

FIG. 1F

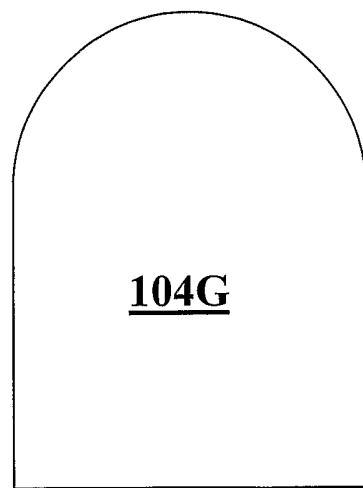

FIG. 1G

4/10

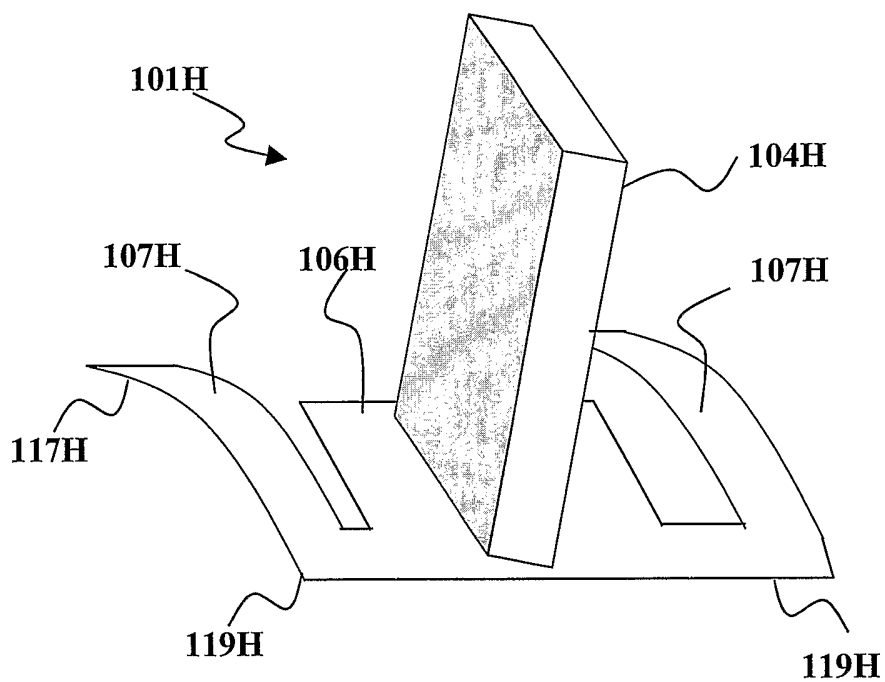

FIG. 1H

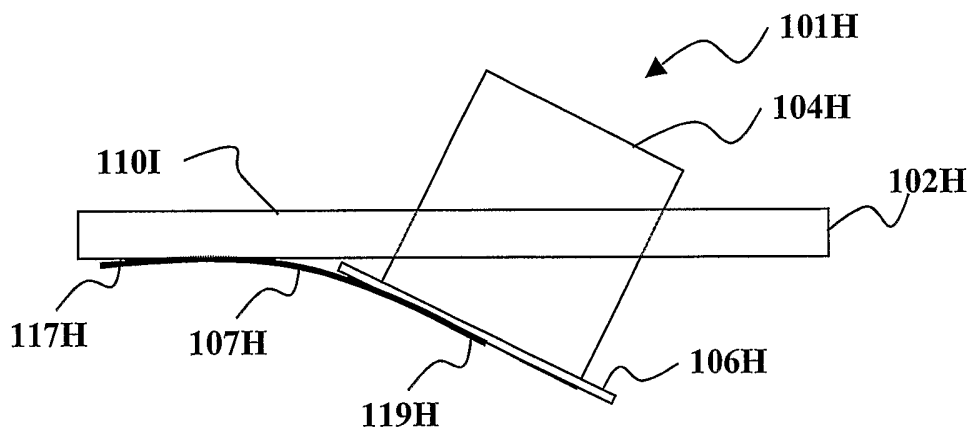

FIG. 1I

5/10

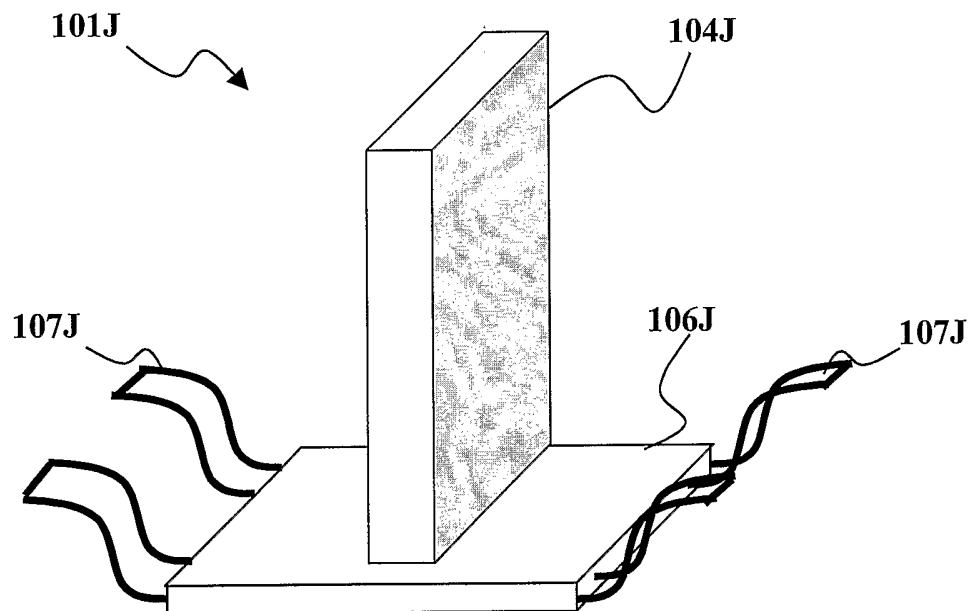

FIG. 1J

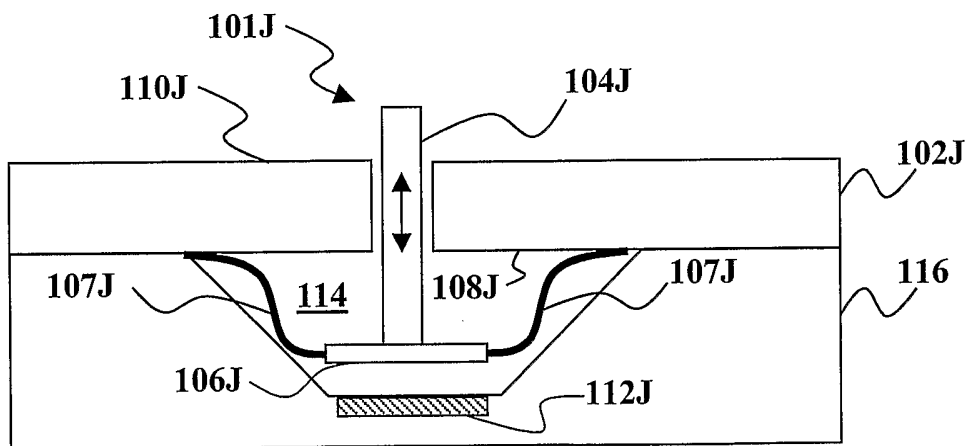

FIG. 1K

6/10

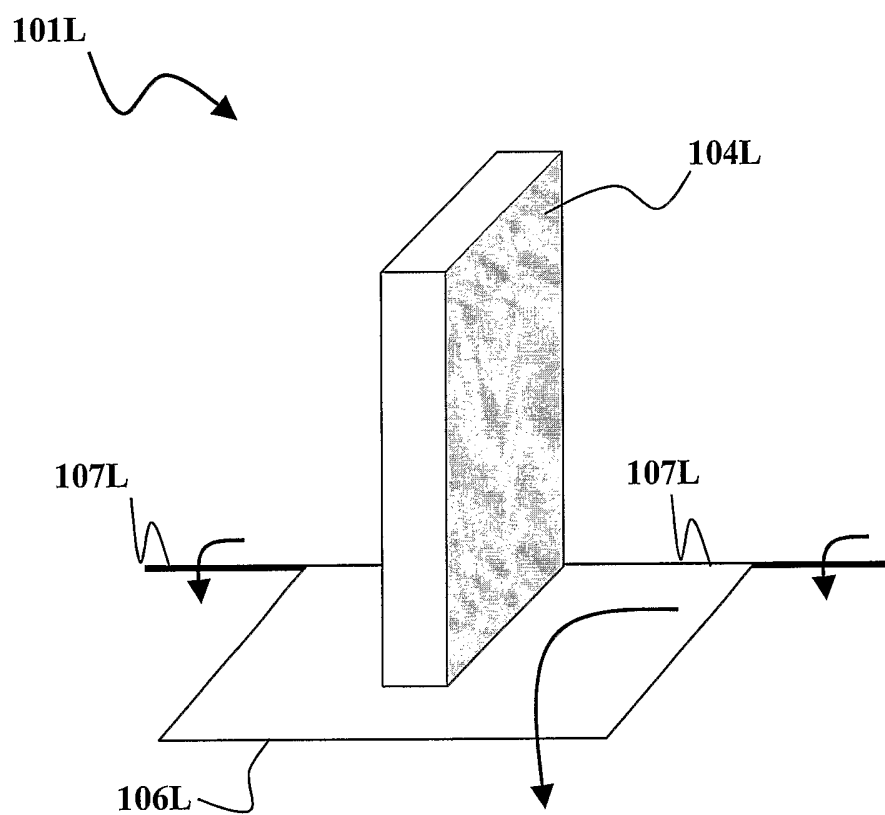

FIG. 1L

7/10

100M

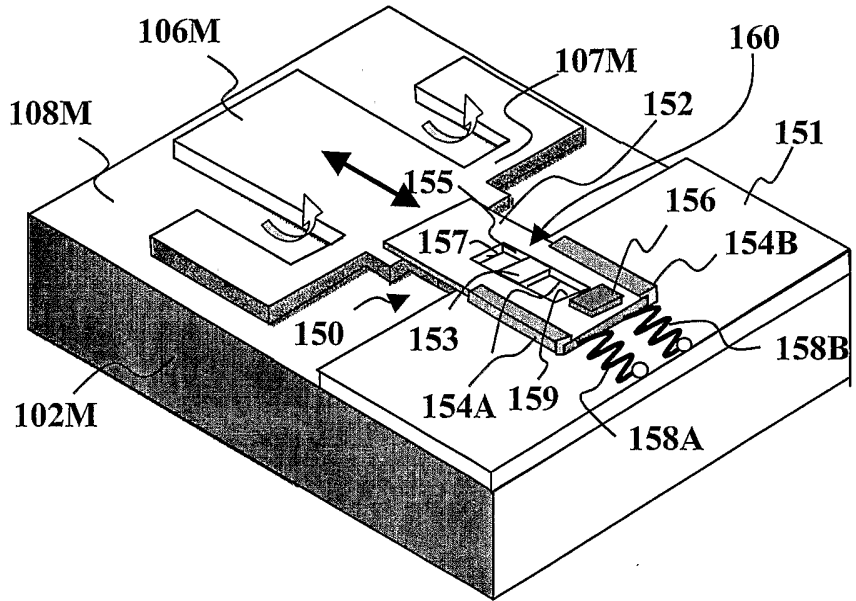

FIG. 1M

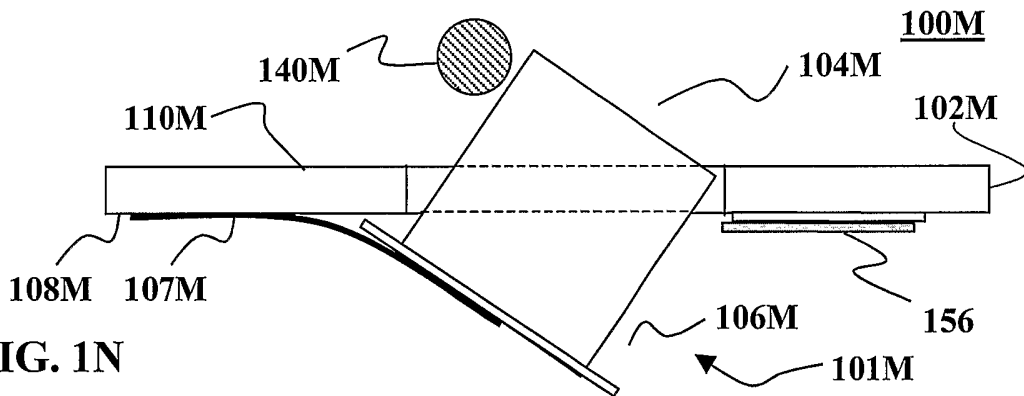

FIG. 1N

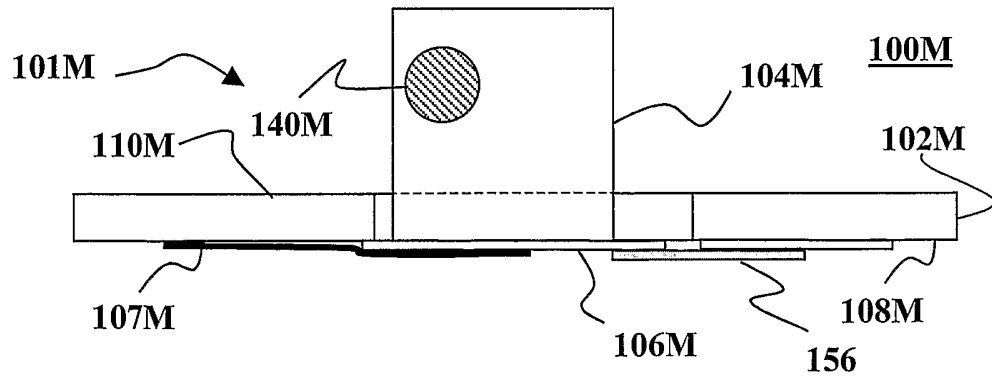

FIG. 1P

8/10

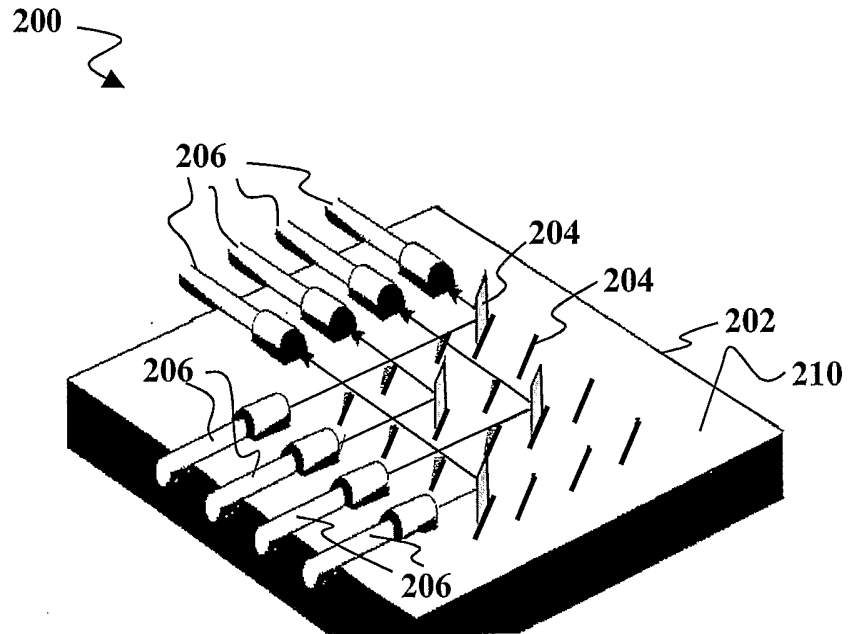
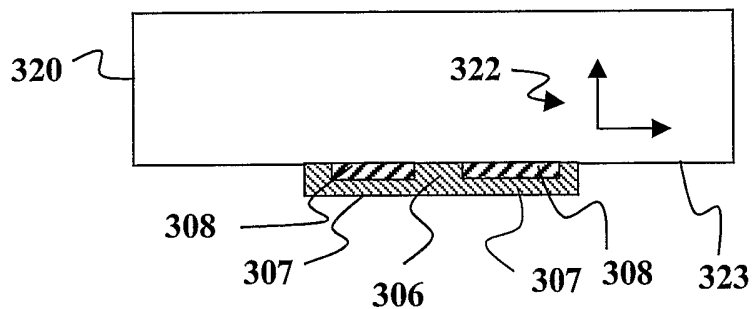

FIG. 2

9/10

301



304

303

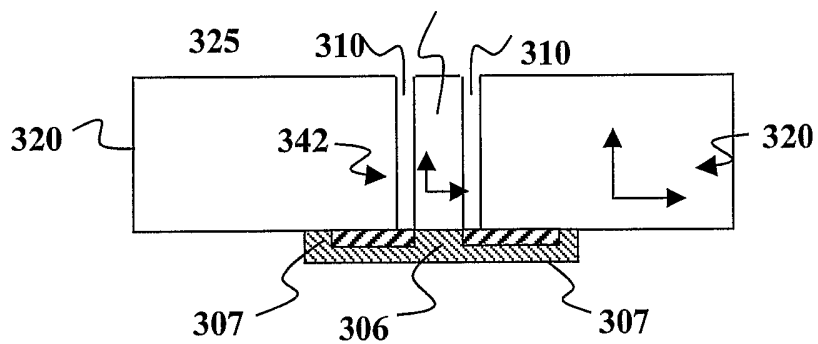

304

305

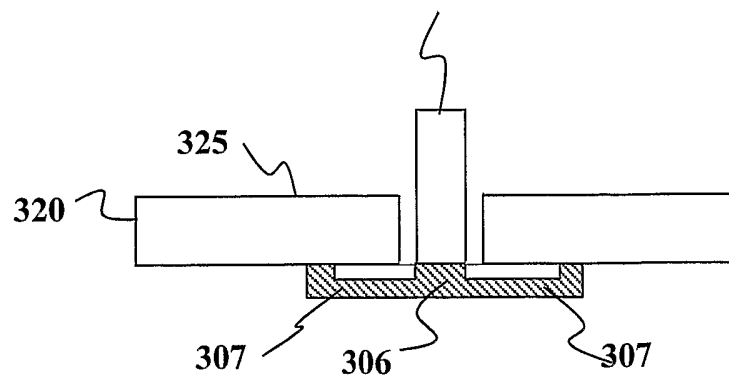

FIG. 3

10/10

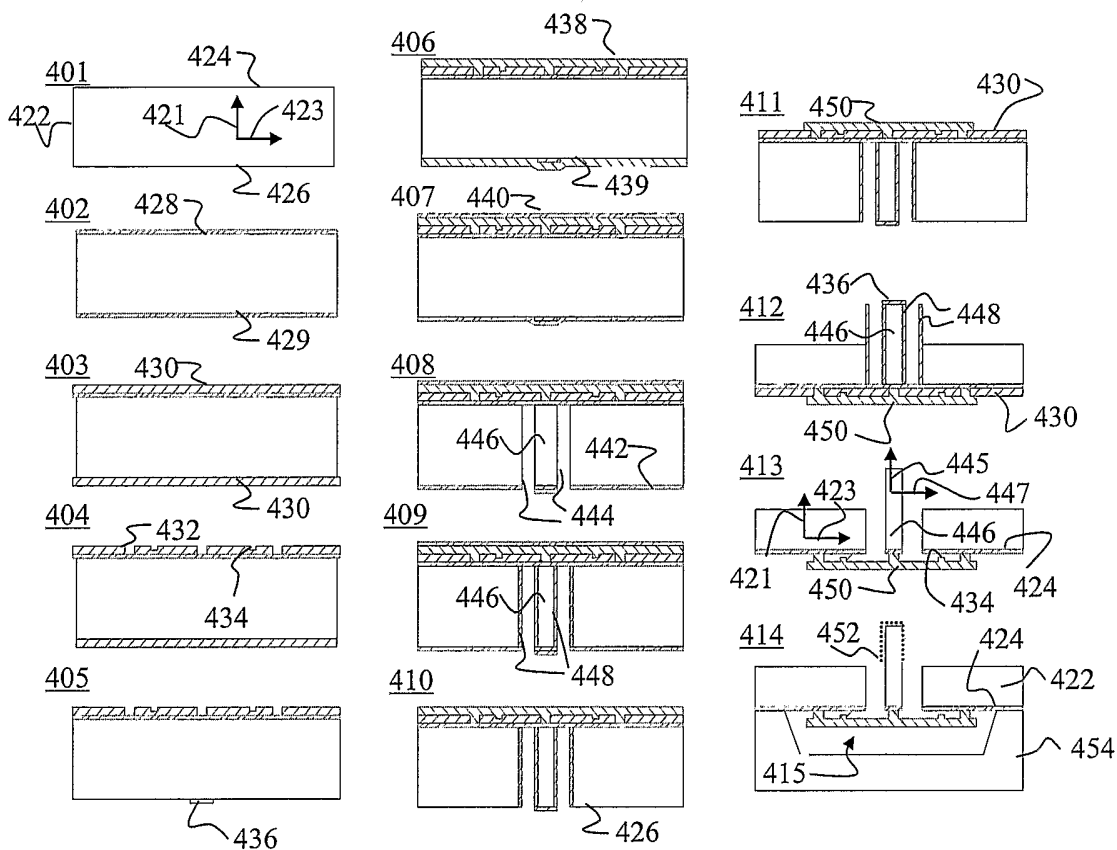

FIG. 4