

(No Model.)

P. O. MARTIN.
ATTACHMENT FOR LANTERNS.

No. 523,223.

Patented July 17, 1894.

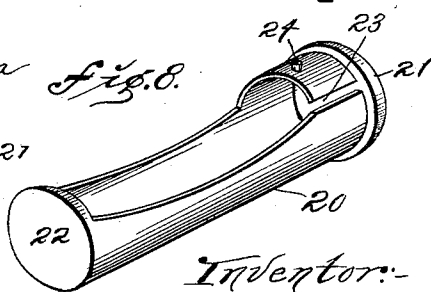
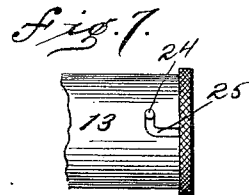
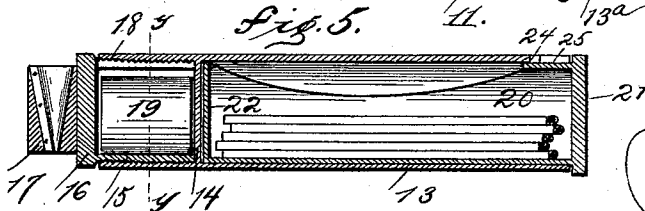
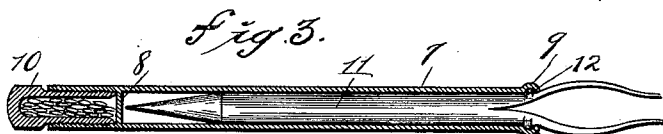
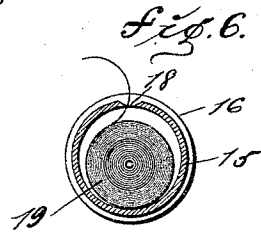
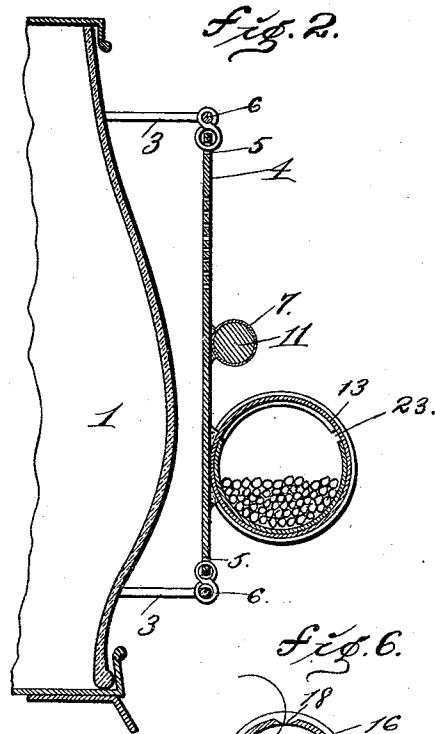
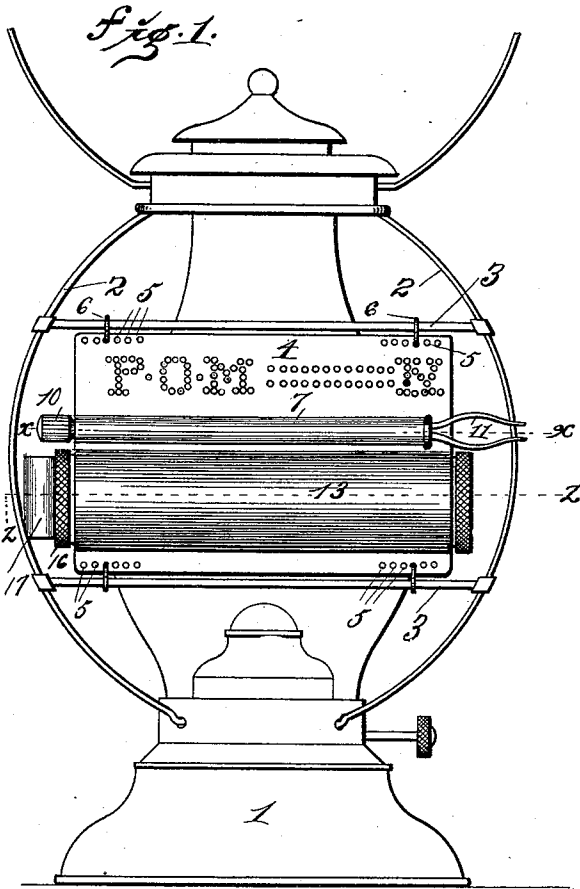

Witnesses:
M. P. Smith.
Wm. J. Banker

Inventor:
Primus O. Martin.
B. Higdon & Higdon & Longan
Attys.

UNITED STATES PATENT OFFICE.

PRIMUS O. MARTIN, OF PADUCAH, KENTUCKY.

ATTACHMENT FOR LANTERNS.

SPECIFICATION forming part of Letters Patent No. 523,223, dated July 17, 1894.

Application filed January 29, 1894. Serial No. 498,299. (No model.)

To all whom it may concern:

Be it known that I, PRIMUS O. MARTIN, of the city of Paducah, McCracken county, and State of Kentucky, have invented certain new and useful Improvements in Attachments for Lanterns, of which the following is a full, clear, and exact description, reference being had to the accompanying drawings, forming a part hereof.

The object of my invention is to provide an attachment provided with compartments that may be attached to lanterns, steam-gage lamps and locomotive cab lights, my invention being especially adapted to carry articles useful to anyone using a lantern, especially railroad employes, and at the same time provide a name plate and reflector for the lamp or lantern to which my device is attached.

To the above purposes my invention consists in certain new and novel features of construction that will be more fully hereinafter described and claimed.

In order that my invention may be more fully understood, I will now proceed to describe it, reference being had to the accompanying drawings, in which—

Figure 1 is a side elevation of a lantern, my improvement being attached thereto. Fig. 2 is a vertical sectional view through the central portion of my device, portions of the lantern also being shown in this view. Fig. 3 is a longitudinal sectional view through the line $x-x$ of Fig. 1. Fig. 4 is a longitudinal sectional view of the modified form shown in Fig. 3. Fig. 5 is a longitudinal sectional view, taken on the line $z-z$ of Fig. 1. Fig. 6 is a vertical sectional view, taken on the line $y-y$ of Fig. 5. Fig. 7 is a top view of a portion of the match case, which I use in my device, Fig. 8 being a perspective view of the match receptacle or safe.

Similar figures refer to similar parts throughout the several views.

1 designates a lantern, such as is commonly used by railroad employes, and is provided with wire-guards 2-2, which, in turn, are strengthened by the guards 3-3.

4 designates a rectangular metal plate, having in each corner a series of apertures 5, provided with hooks or rings 6 for attaching said plate to the wire-guards 3. As lanterns vary in size, by having a series of these apertures

5, the plate can be easily adjusted upon any lantern. The face of this plate 4 toward the globe of the lantern may be polished or bur-
nished, thereby serving as a reflector. The upper portion of this plate may be perforated or stamped with the name of the owner of the lantern, or any name or number desired. To the central portion on the outside of this plate 4, is secured, preferably by solder, a tube 7, said tube having near one end a partition 8. The interior of this cylinder from said partition to the end of the tube, is screw-threaded for a purpose that will be hereinafter stated. On the other end of this tube 7 is formed a bead 9, thus providing an annular groove on the interior of the tube 7.

A hollow plug 10, a portion of its outer periphery being screw-threaded, is adapted to be screwed into the end of the tube 7, which is screw-threaded as previously stated. The interior of this plug forms a receptacle for flax-seed.

A wick-pick and tweezers 11, formed of a single piece of metal, and provided with lugs 12, is adapted to be placed in the tube 7, the lugs 12 engaging in the annular groove, previously mentioned.

When it is desired to remove the wick-pick and tweezers, the portion forming the tweezers extending from the tube 7, is compressed, thereby disengaging the lugs 12 from the annular groove.

In the modified form shown in Fig. 4, a wick-pick alone is shown. In this instance the interior of the tube 7, adjacent the end, is screw-threaded and adapted to engage screw-threads upon the periphery of the wick-pick 11. A head 13^a is formed upon the wick-pick, which forms a hold in engaging or disengaging the wick-pick from the tube.

A tube 13, considerably larger than the previously mentioned tube 7, is secured by means of solder, or in any suitable manner, immediately below the tube 7, and has near one end a partition 14, the interior of the tube from the partition 14 to the end being screw-threaded. A cylindrical plug 15, provided with a head 16 and having its outer periphery screw-threaded, is adapted to screw into the hollow tube 13, to the left of the partition. This cylindrical plug 15 has secured in any suitable manner to its head 16, a pen-

cil sharpener 17, said pencil sharpener being
 of the ordinary construction. A longitudinal
 slot 18 is formed in this plug 15, the edges of
 said slot being knife-edged. The apartment
 5 formed by this plug 15 in the tube 13 is
 adapted to contain a roll of adhesive plaster
 19. A match-box 20, cylindrical in form, hav-
 ing a head 21 and end 22, is adapted to oc-
 10 cupy the remaining space in the tube 13.
 The upper portion of this match-box is cut
 away to a point near the head 21. A slot 23,
 slightly wider than an ordinary match, con-
 nects this cut-away portion with the head 21.
 15 A lug 24, integral with the upper portion of
 this match-box, engages in a right-angle slot
 25 formed in the top of the tube 13, thus
 forming what is commonly known as a bayo-
 net joint.
 When my device is in practical use, it oc-
 20 cupies a position as clearly shown in Fig. 1.
 Should the person desire to use the wick-pick
 and tweezers, he compresses the tweezers, as
 before stated, and removes the pick from the
 tube 7, or if the pick be as shown in Fig. 4,
 25 he unscrews said pick from the tube 7.
 Should a flax-seed or seeds be desired, they
 can be easily obtained by unscrewing the hol-
 low plug 10, containing them. Should it be
 desired to sharpen a lead pencil, the point
 30 thereof is inserted in the pencil sharpener 17,
 and the operation such as used to sharpen
 pencils by this form of device is completed.
 Should a portion of the roll of adhesive plas-
 35 ter contained in the cylindrical plug 15 be de-
 sired, said plug is unscrewed from the tube
 13 and the end of said plaster brought through
 the knife-edged slot 18. When the desired
 amount of plaster has been unrolled, by hold-
 40 ing the roll stationary and bringing the un-
 rolled portion of the plaster against the knife-
 edged slot 18, said portion can be easily and
 quickly cut from the main roll. Should a
 match or matches be desired, the lug 24 of
 45 the match-box is disengaged from the slot 25
 of the tube 7, and the match-box removed.

A match or matches on the interior of the
 match-box can now be easily removed, but by
 reason of the slot 23, as before described and
 clearly shown in Fig. 8, but one match can
 be removed at a time. Thus it will be seen 50
 how I have constructed a name-plate and re-
 flector for lanterns, said plate carrying com-
 partments, which, in turn carry articles very
 useful to users of lanterns, and especially to
 railroad employés.

What I claim is—

1. An attachment for lanterns or railroad
 lights, consisting of a plate having a series of
 holes and hooks, whereby said plate is at-
 60 tached to lanterns or lamps, said plate con-
 structed to form a reflector for the lantern or
 lamp, and having a number of compartments
 in which are located articles useful to the
 carriers of lanterns, substantially as shown
 and described.

2. An attachment for lanterns or railroad
 lamps, consisting of a rectangular plate hav-
 ing a series of apertures and hooks con-
 70 structed to secure said plate to the lantern,
 said plate carrying a tube in which is located
 and held a wick-pick and tweezers, and a hol-
 low plug which forms a compartment in said
 tube, substantially as herein specified and for
 the purposes stated.

3. An attachment for lanterns or railroad 75
 lamps, comprising a rectangular plate having
 a series of holes and hooks to secure the at-
 tachment to lanterns, the plate of said attach-
 ment having on its outer face, a plurality of
 80 tubes in which are located and held a wick-
 pick, a removable receptacle, a receptacle hav-
 ing a knife-edged slot and a pencil sharp-
 ener, as shown and described, for the pur-
 poses stated.

In testimony whereof I affix my signature in 85
 presence of two witnesses.

PRIMUS O. MARTIN.

Witnesses:

S. P. MARTIN,
 L. J. ROUSE.