

H. B. Rowley,
Axle Box.

No. 39,349.

Patented. April 27, 1869.

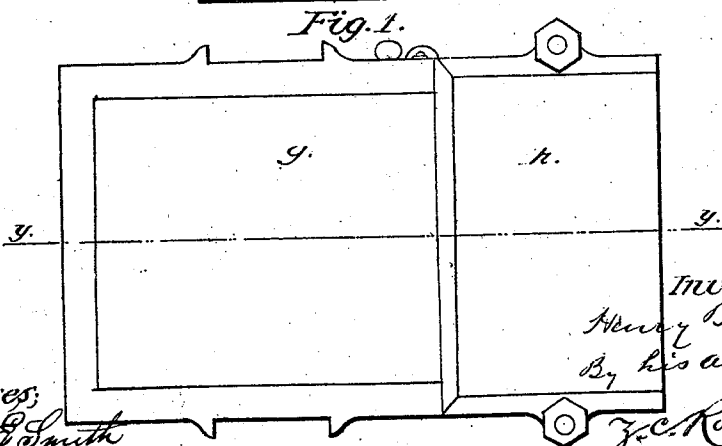
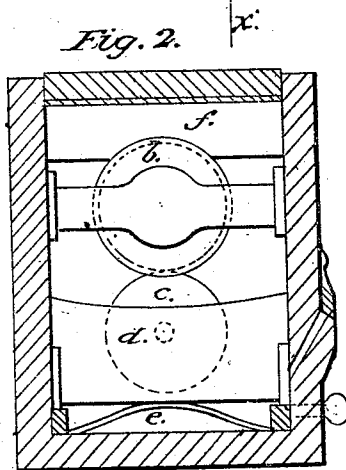
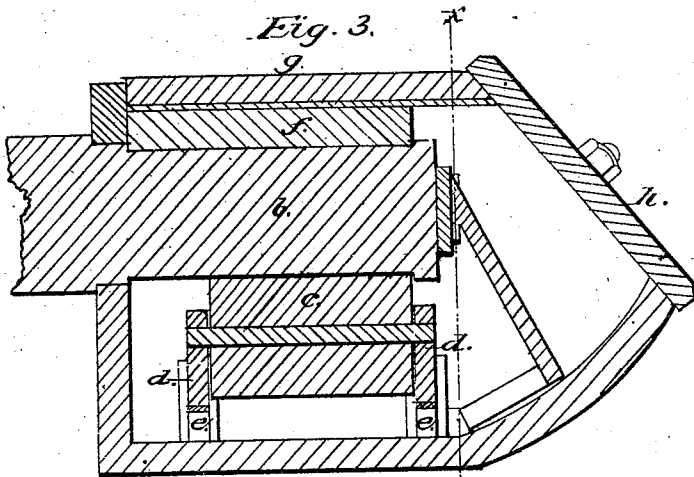

Witnesses;
Sydney C. Smith
J. A. G. Smith

Inventor;
Henry B. Rowley
By his attorney

J. C. Robbins
att.

UNITED STATES PATENT OFFICE.

HENRY B. ROWLEY, OF BUFFALO, ASSIGNOR TO CARRIE R. LAMAN, OF
PAINTED POST, NEW YORK.

IMPROVED JOURNAL-BOX FOR RAILWAY-CARS.

Specification forming part of Letters Patent No. **89,349**, dated April 27, 1869.

To all whom it may concern:

Be it known that I, HENRY B. ROWLEY, of Buffalo, in the county of Erie and State of New York, have invented a new and improved manufacture in the shape of an Improved Journal-Box for Railway-Cars; and I do hereby declare that the following is a full and exact description thereof, reference being had to the accompanying drawings, which form a part of this specification.

Figure 1 is a top view of my said improved journal-box; Fig. 2, a section of the same in the line *x x* of Fig. 3; and Fig. 3, a section in the line *y y* of Fig. 1.

Similar letters indicate like parts in each of the drawings.

The construction of the exterior portion of my improved railway-car journal-box is substantially like that of the best railway-car journal-boxes now in use.

The improvement in my improved journal-box consists in the combination therewith of a pivoted roller, *c*, of vulcanized rubber, in such a manner as to give the said roller such a degree of elastic pressure against the under side of the journal *b* of the car-axle as will cause the rotations of said journal to impart a continuous rotary movement to said roller, and as a portion of this roller is immersed in the oil in the lower portion of the journal-box the said roller will unerringly keep the axle-journal at all times evenly and smoothly lubricated with fresh oil, and without the possibility of wasting any portion of said oil. The

sulphur which forms a component part of the vulcanized-rubber oiling-roller *c* chemically exerts a cooling influence upon the lubricating-oil, and also upon the axle-journal, with which it is constantly in contact. The soft and elastic nature of the vulcanized-rubber bearing-surface of the oiling-roller *c* also insures the continuous rotation of said roller, even when it bears but lightly against the surface of the journal of the car-axle, provided the journal-box be at all times furnished with the requisite supply of oil.

The body of the oiling-roller *c* may, if preferred, be made of any suitable material other than vulcanized rubber, provided the said body be furnished with a suitable covering of vulcanized rubber.

What I claim as my invention, and desire to secure by Letters Patent, as a new and improved manufacture, is—

An improved railway-car journal-box, the improvement therein consisting in the combination therewith of the vulcanized-rubber-surfaced oiling-roller *c*, substantially in the manner herein set forth.

The foregoing specification of my improvement in the journal-boxes of railway-cars signed and witnessed this 5th day of January, 1869.

HENRY B. ROWLEY. [L. S.]

Witnesses:

M. H. BARTO,
H. J. ZUDEICK.