

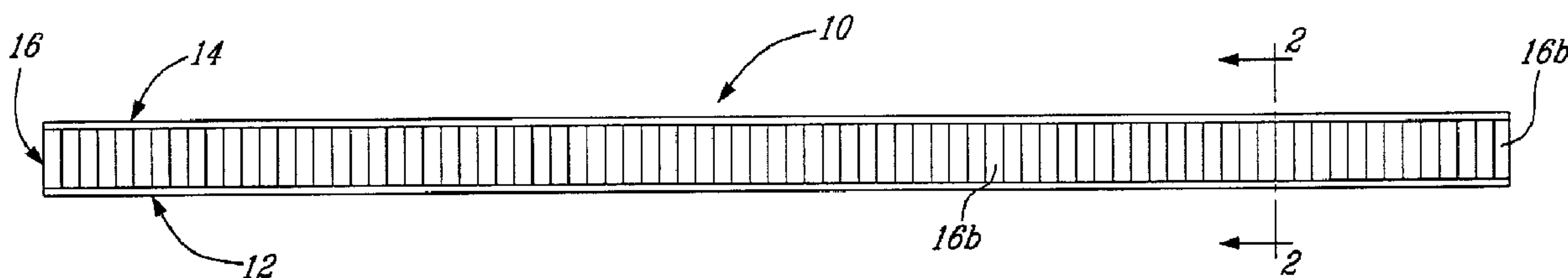

(22) Date de dépôt/Filing Date: 2000/10/05  
(41) Mise à la disp. pub./Open to Public Insp.: 2002/04/05  
(45) Date de délivrance/Issue Date: 2004/03/09

(51) Cl.Int.<sup>7</sup>/Int.Cl.<sup>7</sup> E04C 3/12  
(72) Inventeurs/Inventors:  
VEILLEUX, ROBERT, CA;  
LABRIE, MARIO, CA  
(73) Propriétaire/Owner:  
ROMARO 2000 LIMITEE, CA  
(74) Agent: GOUDREAU GAGE DUBUC

(54) Titre : SOLIVE EN BOIS DE CHARPENTE  
(54) Title: A STRUCTURAL WOODEN JOIST



(57) **Abrégé/Abstract:**

The structural wooden joist described comprises a lower chord, an upper chord spaced from the lower chord and a laminated panel structure joining the chords. This panel structure defines an uninterrupted surface from one end of the joist to an opposite end thereof and has opposite upper and lower edges joined to the lower and upper chords respectively. The laminated panel structure is formed of a series of elongated planks adhesively secured edgewise to one another and extending vertically between the lower and upper chords.

**ABSTRACT**

The structural wooden joist described comprises a lower chord, an upper  
5 chord spaced from the lower chord and a laminated panel structure joining  
the chords. This panel structure defines an uninterrupted surface from one  
end of the joist to an opposite end thereof and has opposite upper and lower  
edges joined to the lower and upper chords respectively. The laminated  
panel structure is formed of a series of elongated planks adhesively secured  
10 edgewise to one another and extending vertically between the lower and  
upper chords.

**TITLE OF THE INVENTION**

A structural wooden joist.

**FIELD OF THE INVENTION**

- 5 The present invention pertains to a structural wooden joist used in building constructions.

**BACKGROUND OF THE INVENTION**

- 10 Wooden joists are used increasingly in a number of building applications. They comprise top and bottom elongated chords with intervening struts joined to the chords by means of scarfing. One such wooden joist may be found described in U.S. patent no. 5,867,963 issued February 9, 1999 to Hershey.

- 15 Some web structures have a triangular configuration such as the joist described in applicant's U.S. patent No. 5,664,393 issued September 9, 1997.

- In U.S. patent No. 4,336,678 issued June 29, 1982, a wooden truss structure is described with a web member formed of sheet material, such as plywood.

20

**OBJECTS AND STATEMENT OF THE INVENTION**

- It is an object of the present invention to provide a novel wooden joist which includes a laminated panel structure formed of short laminated vertical planks  
25 which are adhesively secured to one another by gluing thereby enabling an adjustment of the joist length at the building location by a simple sawing operation.

- This type of joist is used in some cases for closing the peripheral areas of a floor  
30 or ceiling wherein all internal joists are the open type or, in other cases, as a fire barrier.

- 2 -

The present invention therefore relates to a structural wooden joist which comprises:

- a) an elongated lower chord;
- b) an elongated upper chord in a spaced apart opposed relation to  
5 the lower chord; and
- c) a laminated panel structure joining the chords and defining an uninterrupted surface from one end of the joist to an opposite end thereof and having opposite upper and lower edges joined to the lower and upper chords respectively; the laminated panel structure is formed of a series of elongated  
10 planks adhesively secured edgewise to one another and extending vertically between the lower and upper chords.

In one form of the invention, the laminated panel structure has a width equal to the width of the lower and upper chords thereby defining a continuous  
15 rectangular shaped cross-section throughout the length of the joist.

In another form of the invention, the laminated panel structure is formed of two laminated panels extending parallel to and abutting one another.

20 The boards are made of kiln dry wood, preferably one selected from the group that includes fir, spruce and pine.

Other objects and further scope of applicability of the present invention will become apparent from the detailed description given hereinafter. It should be  
25 understood, however, that this detailed description, while indicating preferred embodiments of the invention, is given by way of illustration only, since various changes and modifications within the spirit and scope of the invention will become apparent to those skilled in the art.

30

**BRIEF DESCRIPTION OF THE DRAWINGS**

Figure 1 is an elevational view of a wooden joist made in accordance with the present invention;

5 Figure 2 is a cross-sectional view taken along lines 2-2 of figure 1; and

Figure 3 is a cross-sectional view of another embodiment of the present invention.

10

**DESCRIPTION OF PREFERRED EMBODIMENTS**

Referring to figure 1, there is shown a structural wooden joist, generally denoted 10, which comprises an elongated lower chord 12 and an elongated upper chord 14 in spaced apart generally parallel opposed relation to the lower chord 12.

15

Between the upper and lower chords, is provided a laminated panel structure 16 consisting of a series of vertically extending planks 18.

20

In a first embodiment illustrated in figure 2, the laminated panel structure consists of two laminated panels 16a and 16b extending parallel to and abutting one another. Each panel 16a, 16b consists of a series of vertically extending planks which are adhesively secured in edgewise fashion to one another. They are secured to one another by glue; however, they could also be secured by a V-shaped joint or similar joint.

25

The planks are joined in an endwise manner to the lower and upper chords by scarf joints 18a, 18b and 20a, 20b. Glue is used to secure the joints.

30

In embodiment illustrated in figure 2, the width of the chords 12 and 14 is substantially the same as that of the width of both panels 16a and 16b together thereby providing a continuous rectangular cross-section throughout the length of the joist.

- 4 -

In another embodiment of the invention (see figure 3), there is a single laminated panel 22 which is again formed of a series of adhesively secured vertical planks joined to a lower chord 24 and an upper chord 26 by finger joints 28 and 30.  
5 Again, glue may be used to secure the planks together or V-shaped or similar joints.

The wood used for all planks of the panels is kiln dry wood preferably one selected from the group consisting of fir, spruce and pine. The wood fibers  
10 extend in the longitudinal direction of the plank.

Also, the glue used in securing the planks together as well as that used in the scarfing is one preferably having a base of resin resorcinol, such as phenol resorcinol resin, or one having a base of urethane, or one approved for structural  
15 wood.

Although the invention has been described above with respect to one specific form, it will be evident to a person skilled in the art that it may be modified and refined in various ways. For example, the opposite end regions of the joist may  
20 be sawed off to form inserts in a truss such as the one described for example in the above identified U.S. patent to Hershey. It is therefore wished to have it understood that the present invention should not be limited in scope, except by the terms of the following claims.

## CLAIMS

1. A structural joist made entirely of wooden components whereby said joist may be sawed off to form inserts in a truss; said components comprising:

- a) an elongated wooden lower chord;
  - b) an elongated wooden upper chord in a spaced apart opposed relation to said lower chord; and
  - c) a laminated panel structure joining said chords; said laminated panel structure defining an uninterrupted surface from one end of the joist to an opposite end thereof and having opposite upper and lower edges adhesively joined to said lower and upper chords respectively; said laminated panel structure being formed of a series of elongated wooden planks adhesively secured edgewise to one another and extending vertically between said lower and upper chords;
- said joist being free of metallic parts so as to enable sawing sections thereof to form wooden inserts in structural trusses.

2. A structural joist made entirely of wooden components whereby said joist may be sawed off to form inserts in a truss; said components for closing peripheral areas of a floor joist structure comprising:

- a) an elongated wooden lower chord having a given width;
- b) an elongated wooden upper chord in spaced apart opposed relation to said lower chord and having a width equal to the width of said lower chord; and
- c) a laminated structure joining said chords; said laminated panel structure defining an uninterrupted surface having opposite lower and upper edges adhesively joined to said lower and upper chords respectively; said laminated panel structure being formed of a series of elongated wooden planks adhesively secured edgewise to one another; said laminated panel structure having a width equal to the width of said lower and upper chords thereby defining a continuous rectangular shaped cross-section throughout the longitudinal direction of said joist;

said joist being free of metallic parts so as to enable sawing sections thereof to form wooden inserts in structural trusses.

3. A structural joist as defined in claim 1 or 2, wherein said laminated panel structure is formed of two laminated panels extending parallel to and abutting one another, each said panel being formed of a series of elongated planks secured edgewise to one another.

4. A structural joist as defined in claim 1, 2 or 3, wherein said panel is secured to said chords by finger joints.

5. A structural joist as defined in claim 4, wherein said planks are adhesively secured to one another by means of a glue having a base of resin resorcinol.

6. A structural joist as defined in claim 2, wherein said planks extend perpendicularly to said chords.

7. A structural joist as defined in any one of claims 1 to 6, wherein said planks are made of kiln dry wood.

8. A structural joist as defined in claim 7, wherein said wood is selected from the group including fir, spruce and pine.

9. A structural joist as defined in any one of claims 1 to 8, wherein fibres in said planks extend in the longitudinal direction of said planks.

10. A structural joist as defined in any one of claims 1 to 9, wherein said planks are joined to one another by a V-shaped joint.

