

(19) World Intellectual Property Organization
International Bureau



(43) International Publication Date
3 March 2011 (03.03.2011)

PCT

(10) International Publication Number
WO 2011/025920 A1

- (51) **International Patent Classification:**
G01R 27/26 (2006.01)
- (21) **International Application Number:**
PCT/US2010/046919
- (22) **International Filing Date:**
27 August 2010 (27.08.2010)
- (25) **Filing Language:** English
- (26) **Publication Language:** English
- (30) **Priority Data:**
12/548,540 27 August 2009 (27.08.2009) US
- (71) **Applicant (for all designated States except US):** ANALOG DEVICES, INC. [US/US]; One Technology Way, Norwood, MA 02062-9106 (US).
- (72) **Inventors; and**
- (75) **Inventors/Applicants (for US only):** IRIARTE, Santiago [ES/ES]; Jeronimo Monsoriu 85, Valencia (ES). MURPHY, Mark [IE/IE]; Aherinagh Beg, Kilmore, Country Clare (IE).
- (74) **Agents:** HAILS, Robert, L. et al.; Kenyon & Kenyon LLP, 1500 K Street, N.w., Washington, DC 20005 (US).

(81) **Designated States** (unless otherwise indicated, for every kind of national protection available): AE, AG, AL, AM, AO, AT, AU, AZ, BA, BB, BG, BH, BR, BW, BY, BZ, CA, CH, CL, CN, CO, CR, CU, CZ, DE, DK, DM, DO, DZ, EC, EE, EG, ES, FI, GB, GD, GE, GH, GM, GT, HN, HR, HU, ID, IL, IN, IS, JP, KE, KG, KM, KN, KP, KR, KZ, LA, LC, LK, LR, LS, LT, LU, LY, MA, MD, ME, MG, MK, MN, MW, MX, MY, MZ, NA, NG, NI, NO, NZ, OM, PE, PG, PH, PL, PT, RO, RS, RU, SC, SD, SE, SG, SK, SL, SM, ST, SV, SY, TH, TJ, TM, TN, TR, TT, TZ, UA, UG, US, UZ, VC, VN, ZA, ZM, ZW.

(84) **Designated States** (unless otherwise indicated, for every kind of regional protection available): ARIPO (BW, GH, GM, KE, LR, LS, MW, MZ, NA, SD, SL, SZ, TZ, UG, ZM, ZW), Eurasian (AM, AZ, BY, KG, KZ, MD, RU, TJ, TM), European (AL, AT, BE, BG, CH, CY, CZ, DE, DK, EE, ES, FI, FR, GB, GR, HR, HU, IE, IS, IT, LT, LU, LV, MC, MK, MT, NL, NO, PL, PT, RO, SE, SI, SK, SM, TR), OAPI (BF, BJ, CF, CG, CI, CM, GA, GN, GQ, GW, ML, MR, NE, SN, TD, TG).

Published:
— with international search report (Art. 21(3))

(54) **Title:** SYSTEM AND METHOD FOR MEASURING CAPACITANCE

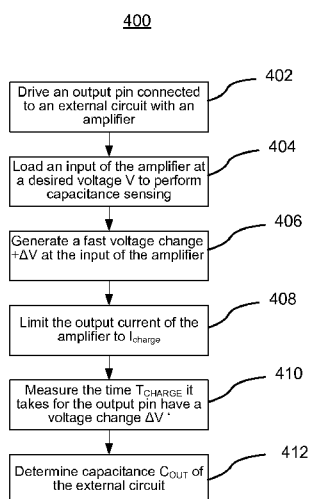

FIG. 4

(57) **Abstract:** A system and method for testing capacitance of a load circuit connected to an output pin of a driving circuit. In one embodiment, the method may comprise driving a voltage at the output pin to a first voltage; a predetermined current to the output pin; comparing the voltage at the output pin to a reference voltage; and when the voltage at the output pin matches the reference voltage, generating an estimate of capacitance present at the output pin based on a number of clock cycles occurring between an onset of a timed voltage change period and a time at which the voltage at the output pin matches the reference voltage.



WO 2011/025920 A1

SYSTEM AND METHOD FOR MEASURING CAPACITANCE

Inventors: Santiago Iriarte and Mark Murphy

BACKGROUND

[01] The present invention is generally directed to testing capacitance of a circuit. In particular, the present invention is directed to a device and method for detecting the capacitance of a circuit coupled to an output of a driving circuit.

[02] Testing capacitance of a circuit has long been performed. Testing capacitance of a circuit coupled to an output of a driving circuit (e.g., an IC chip) has posted a new challenge. Nowadays, integrated circuits chips are widely used to control or drive a variety of actuators (e.g., micro actuator, MicroElectroMechanical Systems (MEMS) actuator). For example, ICs are used in electronic appliances such as cameras to control or drive a motor that drives an adjustable mechanical component (e.g., a lens). An actuator coupled to an IC chip may appear as a capacitor coupled to an output pin of the IC chip.

[03] It would be desirable for an IC chip to test capacitance of a circuit coupled to an output of the IC chip (e.g., to determine on its own whether a load device is connected to chip pin before driving the pin with an activating current.) No known tests are available that provide a simple, inexpensive circuit for this purpose. Accordingly, there is a need in the art for a circuit that efficiently tests for capacitance of a circuit coupled to an IC pin with minimal complexity.

BRIEF DESCRIPTION OF THE DRAWINGS

[04] FIGs. 1A and 1B are schematic diagrams of a capacitance sensing circuit in accordance with an exemplary embodiment of the present invention.

[05] FIG. 2 is a graph illustrating exemplary signal outputs of a capacitance sensing circuit in accordance with an exemplary embodiment of the present invention.

[06] FIG. 3 is a graph illustrating exemplary signal outputs of a capacitance sensing circuit in accordance with an exemplary embodiment of the present invention.

[07] FIG. 4 is a flow diagram illustrating a process of using a capacitance sensing circuit in accordance with an exemplary embodiment of the present invention.

[08] FIG. 5 is a schematic diagram of a capacitance sensing circuit in accordance with an exemplary embodiment of the present invention.

[09] FIG. 6 is a graph illustrating exemplary signal outputs of a capacitance sensing circuit in accordance with an exemplary embodiment of the present invention.

[10] FIG. 7 is a flow diagram illustrating a process of using a capacitance sensing circuit in accordance with an exemplary embodiment of the present invention.

DETAILED DESCRIPTION

[11] A system and method for testing capacitance of a load circuit connected to an output pin of a driving circuit. In one embodiment, the method may comprise driving a voltage at the output pin to a first voltage; a predetermined current to the output pin; comparing the voltage at the output pin to a reference voltage; and when the voltage at the output pin matches the reference voltage, generating an estimate of capacitance present at the output pin based on a number of clock cycles occurring between an onset of a timed voltage change period and a time at which the voltage at the output pin matches the reference voltage.

[12] FIG. 1A is a schematic diagram of a capacitance sensing circuit 100 in accordance with an exemplary embodiment of the present invention. The capacitance sensing circuit 100 may comprise an amplifier 102, a comparator 104 and a counter (e.g., timer) 108. The amplifier 102 may generate an output voltage that is applied to an output pin 110. The comparator 104 may compare the voltage applied to the output pin 110 to a reference voltage V_{REF} . In one embodiment, the capacitance sensing circuit 100 may be provided within a common IC chip. A load circuit (e.g. a load device modeled as capacitor 106 in FIG. 1) may be coupled to the IC chip via the pin 110.

[13] The amplifier 102 may take an input signal V_{IN} at one input pin and take the output voltage V_{OUT} at another input pin via a feedback path. The output voltage V_{OUT} may match the input voltage V_{IN} with a response delay. The response delay may be affected by how fast the voltage V_{OUT} may match to the V_{IN} . Thus, the response delay may be affected by how fast the load circuit may be charged. In this embodiment, the charge current may be provided by the output current of the amplifier 102, which may be controlled by a current source 112. The current source 112 may provide a constant charge current I_{CHARGE} to the output electrical current of the amplifier 102. In one embodiment, the amplifier 102 may be

a voltage output amplifier and the input V_{IN} may be coupled to an output from a digital to analog converter (DAC). In another embodiment, the feedback signal may be coupled via a resistive divider.

[14] The comparator 104 and counter 108 may estimate the response time for the load circuit coupled to the pin 110 to be charged to a certain voltage. For example, if a load device (e.g., capacitor 106) is coupled to the pin 110, the load device may have a capacitance. The capacitance may be determined by the response delay for output voltage V_{OUT} to match the reference voltage V_{REF} . The output signal V_{COMP} of the comparator 104 may be coupled to an input pin of the counter 108. Another input pin of the counter 108 may be coupled to a clock signal F_{CLK} . Thereby, the counter 108 may count the response time (e.g., the response delay) for the output voltage V_{OUT} to match the reference voltage V_{REF} . Accordingly, the capacitance of the load circuit may be determined. In one embodiment, the counter 108 may be part of a decision logic (not shown) the capacitance sensing circuit 100 to estimate the capacitance of the load circuit coupled to the pin 110. The estimation of the capacitance may be based on the estimated response time for the load circuit coupled to the pin 110 to be charged to the reference voltage. In one or more embodiments, whether a load device may be present may be determined based on the capacitance.

[15] In the embodiment as shown in FIG. 1A, the output signal V_{OUT} may be connected to the input pin of the comparator 104 directly for the comparator 104 to compare V_{OUT} to V_{REF} .

[16] In another embodiment, the reference voltage used by the comparator 104 may be the input voltage V_{IN} . Thus, the output voltage V_{OUT} may be compared with the input voltage V_{IN} . The capacitance may be determined by the response delay for output voltage V_{OUT} to match the input voltage V_{IN} . However, as shown in FIG. 2 (a), the rise of the output voltage V_{OUT} may not be linear when the level approaches the input voltage V_{IN} . Therefore, the output signal V_{OUT} may be connected to an input pin of the comparator 104 via an offset voltage V_{OFF} (shown in dashed lines).

[17] FIG. 1B is a schematic diagram of showing the capacitance sensing circuit 100 with more detail in the output portion of the amplifier 102. The output portion of the amplifier 102 may comprise a transistor 114 and the current source 112 may be coupled to one terminal of the transistor 114. The output pin 110 may be coupled to another terminal of the transistor 114. The control terminal of the transistor 114 may be coupled to an output

of the amplifier 102. In the embodiment shown in FIG. 1B, the transistor 114 may be a PMOS transistor. However, the transistor 114 is not limited to only PMOS transistors but may be a NMOS transistor or a bipolar transistor (either p-channel or n-channel).

[18] In one embodiment, the capacitance sensing circuit 100 may comprise another transistor (e.g., a NMOS transistor, not shown) as a current sink coupling the drain of the PMOS transistor 114 to ground. The gate of the NMOS transistor may be coupled to the output of the amplifier 102 similar to the PMOS transistor 114. Because the PMOS transistor 114 may inverse the output signal of the amplifier 102, the positive and negative inputs to the amplifier 102 of Fig. 1B may be switched compared to the amplifier 102 of Fig. 1A to generate similar output signals at the output pin 110. Other components of the capacitance sensing circuit 100 shown in FIG. 1B may function similarly to the counterparts shown in FIG. 1A.

[19] FIG. 2 illustrates exemplary waveforms that may be generated by the system of FIG. 1. For the embodiment shown in FIG. 2, the reference voltage V_{REF} may be set to be V_{IN} . FIG. 2(a) illustrates the output voltage V_{OUT} of the amplifier 102 generated in response to an input voltage V_{IN} . From time t_0 to time t_1 , V_{IN} and V_{OUT} are at the same voltage level. At time t_1 , V_{IN} may have a sudden change by an amount of ΔV . The output signal V_{OUT} will change during the time from t_1 to t_2 based on a capacitance C_{OUT} present at the output pin 110 as follows:

$$\frac{dV_{OUT}}{dt} = \frac{I_{CHARGE}}{C_{OUT}} .$$

At some time later (t_2), V_{OUT} may reach to within a predetermined range of V_{IN} and lose the linear rising rate. The counter 108 may stop counting at the time t_2 . The count value may be read from the counter 108 and analyzed to determine the value of C_{OUT} . If a load device is absent, the value of C_{OUT} will be low. V_{OUT} may reach V_{IN} almost instantly and a relatively low count value for the counter 108 will occur. By contrast, if a load device is present, a larger value of C_{OUT} will be observed and a higher count value will occur.

[20] FIG. 2(b) illustrates the comparator's output signal V_{COMP} in response to waveforms of FIG. 2(a) when the output voltage V_{OUT} is connected to the comparator 104 via the offset voltage V_{OFF} . When the input voltage V_{IN} is greater than the voltage at the output pin V_{OUT} plus the offset voltage V_{OFF} , the counter 108 is enabled. FIG. 2(c) illustrates the counter 108 counting from time t_1 to time t_2 , but being disabled from counting again at time t_2 . At time

t_2 , the comparator 104 triggers when V_{OUT} reaches to within a predetermined range of V_{IN} . After time t_2 , the count value may be maintained at the counter 108 until it is reset. In one embodiment, the counter 108 may be reset by a reset signal as shown in FIG. 1.

[21] In one embodiment, the comparator 104 may be triggered when V_{OUT} reaches to within a threshold offset value V_{OFF} of V_{IN} . For the purpose of determining the capacitance C_{OUT} , an offset voltage V_{OFF} may ensure that the amplifier 102 is still slewing (e.g., voltage change is linear) when the comparator 104 triggers. Also, the signals of the amplifier 102 and the comparator 104 may have error sources and not be as ideal as shown in FIG. 2(a). Thus, the offset voltage V_{OFF} may provide a safety factor and may need to be bigger than a combined offset of the amplifier 102 and the comparator 104. The capacitance C_{OUT} present at the output pin 110 may be determined as follows:

$$C_{OUT} = \frac{I_{CHARGE}}{\Delta V - V_{OFF}} (t_2 - t_1)$$

[22] In one or more embodiments, the capacitance C_{OUT} may vary with the applied voltage, thus, the input V_{IN} to the amplifier 102 may keep the pin 110 at a desired voltage V and a small ΔV may help to more accurately determine the capacitance close to the desired voltage V . On the other hand, the voltage change value ΔV may be limited by the offset voltage, because ΔV must be larger than the V_{OFF} .

[23] In the exemplary embodiment shown in FIG. 1, V_{IN} may be connected to the inverting input and V_{OUT} may be connected to the non-inverting input of the comparator 104. However, in another embodiment, the connection may be switched, e.g., V_{IN} may be connected to the non-inverting input and V_{OUT} may be connected to the inverting input of the comparator 104, and the offset voltage V_{OFF} may be applied accordingly as well.

[24] FIG. 3 illustrates exemplary signal outputs of the capacitance sensing circuit 100 in accordance with another exemplary embodiment of the present invention. In contrast to FIG. 2, for the embodiment shown in FIG. 3, the reference voltage V_{REF} may be set other than the input voltage V_{IN} . As shown in FIG. 3, at time t_1 , the input V_{IN} may have a step change ΔV from an initial voltage level V . Also at time t_1 , the reference voltage V_{REF} may be set to a level of $V + \Delta V_1$ with ΔV_1 to be less than ΔV , and thus reference voltage V_{REF} to be less than the input voltage V_{IN} at time t_1 . The time t_2 may be determined by triggering of the comparator 104 when the output voltage V_{OUT} matches the reference voltage V_{REF} of $V + \Delta V_1$. The comparator 104 may trigger the counter 108 to start counting the time. At the

time t_2 , the reference voltage V_{REF} may be set to a new value $V + \Delta V_1 + \Delta V_2$, with $\Delta V_1 + \Delta V_2$ to be less than the input change ΔV and the rise of the output voltage V_{OUT} to be still linear. The comparator 104 may have a short response time $t_3 - t_2$ to trigger again after the output voltage V_{out} does not match reference voltage V_{REF} any more. But at the time t_3 , the counter 108 may not be affected and keep counting. At time t_4 , the output voltage V_{OUT} matches to the reference voltage V_{REF} again and the comparator 104 may be triggered again. The counter 108 may then be triggered to stop counting at the time t_4 . The capacitance C_{OUT} present at the output pin 110 may be determined by the equation of:

$$C_{OUT} = \frac{I_{CHARGE}}{\Delta V_2} \cdot (t_4 - t_2) .$$

[25] In one or more embodiments, the capacitance C_{OUT} may vary according to the voltage applied to the load circuit. In one embodiment, the output voltage V_{out} may be driven to a desired voltage by the input voltage V_{IN} . Then the step change ΔV may be applied to V_{IN} , and the two step changes ΔV_1 and ΔV_2 may be applied to reference voltage V_{REF} . The two step changes ΔV_1 and ΔV_2 may be equal or different but the output voltage V_{OUT} during these two changes may be linear. Using the two triggering of the comparator may help avoid system errors (e.g., slewing and/or response delay for the comparator) because the charge period is counted between the two triggering of the comparator when V_{OUT} twice matches to the reference voltage V_{REF} .

[26] FIG. 4 illustrates a method 400 of using a load detector circuit in accordance with an exemplary embodiment of the present invention. The method 400 may start with step 402. At step 402, the method 400 configures an electrical circuit (e.g., a driving circuit) to drive a load circuit (e.g., a load device) with an amplifier. The amplifier may be, for example, a voltage output amplifier. As shown in FIG. 1, an exemplary embodiment may use the amplifier 102 to drive an external load device. The load device may be a motor with a capacitance C_{OUT} . The load device may be coupled to the output pin 110, which is electrically connected to output of the amplifier 102. Next, at step 404, the method 400 may load an input of the amplifier at a desired voltage V to perform capacitance sensing. In one or more embodiments, the capacitance of the load circuit C_{OUT} may vary with the applied voltage, thus, the capacitance sensing may be performed at or about the desired voltage.

[27] From step 404, the method 400 may proceed to step 406. At step 406, the method 400 may generate a fast voltage change $+\Delta V$ at the input of the amplifier. As describe

above, the amplifier's output voltage will rise in response to the voltage change ΔV at the input. Next, at step 408, the method 400 may limit the output current of the amplifier to I_{CHARGE} . Thus, the load circuit may be charged by a certain current I_{CHARGE} . In one embodiment, the charge current I_{CHARGE} may be controlled by a current source coupled to the output of the amplifier (as shown in FIG. 1). Next, the method 400 may proceed to step 410. At step 410, the method 400 may measure the time T_{CHARGE} it takes for the voltage at the output pin to have a voltage change $\Delta V'$ (e.g., $\Delta V - V_{OFF}$ in FIG. 2, or ΔV_2 in FIG. 3). For example, a comparator may compare the two inputs of the amplifier 102 as shown in FIG. 1. In one embodiment, an offset Voltage V_{OFF} may be added to the comparator. V_{OFF} may need to be bigger than the combined offset of the amplifier and the comparator. Also, an offset voltage V_{OFF} may ensure that the amplifier is still slewing when the comparator triggers. T_{CHARGE} may be $t_2 - t_1$ as shown in FIG. 2 or $t_4 - t_2$ as shown in FIG. 3.

[28] At step 412, the capacitance C_{OUT} of the load device may be determined. In one embodiment, the voltage change $\Delta V'$ may be the input voltage change with an offset value (as shown in FIG. 2), the capacitance C_{OUT} may be calculated as follows:

$$C_{OUT} (V) = \frac{I_{CHARGE} \cdot T_{CHARGE} (V)}{\Delta V - V_{OFF}}$$

In another embodiment, the voltage change $\Delta V'$ may be a change by the reference voltage V_{REF} , and the capacitance C_{OUT} may be calculated as follows:

$$C_{OUT} = \frac{I_{CHARGE} \cdot (t_4 - t_2)}{\Delta V_2}$$

In one or more embodiment, based on the capacitance C_{OUT} , a determination may be made as to whether the load device is present. For example, a threshold value for the C_{OUT} may be 300 picofarad (pF). That is, a C_{OUT} larger than 300 pF may be sufficient for the capacitance sensing circuit 500 to determine a load (e.g., a motor) is present. And a C_{OUT} less than 300 pF may show that a motor is absent.

[29] FIG. 5 illustrates a capacitance sensing circuit 500 in accordance with an exemplary embodiment of the present invention. The capacitance sensing circuit 500 may comprise an amplifier 502, a comparator 504, a counter 508, a test switch 522, a current switch 524 and a current source 512. An output pin 510 may be coupled to the output of the amplifier 502, to which a load device 506 may be electrically connected. The comparator 504 may compare the voltage level V_{OUT} at the output pin 510 to a reference voltage V_{REF} . Based on

the comparison, the counter 508 may count the time for the voltage level V_{OUT} at the output pin 510 to be charged to the reference voltage V_{REF} . In one embodiment, the counter 508 may be part of decision logic (not shown) of the capacitance sensing circuit 500 to estimate the capacitance of the load device 506. The estimation of the capacitance may be based on the estimated response time for the load circuit coupled to the pin 510 to be charged to the reference voltage.

[30] In some embodiments, one input of the amplifier 502 may be coupled to an output from a digital to analog converter (DAC). A second input pin of the amplifier 502 may be coupled to the output signal $V_{OUT'}$ of the amplifier 502 via a feedback path. During the operations, after the switch 522 is disconnected, the voltage level V_{OUT} at the output pin 510 may be different from the output signal $V_{OUT'}$ of the amplifier 502. In one embodiment, the amplifier 502 may be a voltage output amplifier. In one embodiment, the DAC may be a 10 bits DAC (e.g., output having 2^{10} levels). Also, in one embodiment, the feedback signal may be coupled via a resistive divider.

[31] During normal operations, the switch 522 may be on (e.g., connected) and the switch 524 may be off (e.g., disconnected). The amplifier 502 may drive the output (e.g., the load device 506 coupled to the output pin 510). The capacitance sensing components (e.g., the comparator 504, the counter 508 and the current source 512) may be in a standby mode.

[32] In the capacitance sensing circuit 500, the current source 512 may be coupled to the output pin via the switch 524. This may be different from the capacitance sensing circuit 100 shown in FIG. 1, in which the charge current provided by the current source 112 may be provided via the output of the amplifier 102. In a capacitance sensing operation, the amplifier 502 may drive the output pin to a desired voltage level. Then the switch 522 may be turned off (e.g., disconnected) and the switch 524 may be turned on (e.g., connected). Afterwards, the reference voltage provided to the comparator may have a sudden change (e.g., a step change as shown in Fig. 6(a)). Thus, the output pin 510 and the external circuit (e.g., load device 506) may be driven by the current source 512. The current source 512 may be external to the amplifier 502 and not affected by the amplifier 502's operation. Thus, the rise of the output voltage V_{OUT} may rise linearly. In contrast, in an embodiment according to FIG. 1, when output voltage V_{OUT} (hence, the feedback input to the amplifier 102) gets closer the input voltage V_{IN} , the rise of the output voltage V_{OUT} may not be linear.

[33] FIG. 6 illustrates exemplary signal outputs of the capacitance sensing circuit 500 in accordance with another exemplary embodiment of the present invention. As shown in FIG. 6, at time t_1 , the reference voltage V_{REF} may be set to a level of $V + \Delta V_1$ and the comparator 504 may trigger the counter 508 to start counting the time. Also at time t_1 , the output voltage V_{OUT} at the output pin 510 may start rising in response to the switch 524 being turned on (e.g., connected) and thus the output pin 510 starting to be charged by the current source 512. At the time t_2 , the output voltage V_{OUT} matches to the reference voltage V_{REF} and the comparator 104 may be triggered to send a signal to stop the counter 508. The capacitance C_{OUT} present at the output pin 110 may be determined by the equation of:

$$C_{OUT} = \frac{I_{CHARGE} \cdot (t_2 - t_1)}{\Delta V_1} .$$

[34] FIG. 7 illustrates a method 700 of using a load detector circuit in accordance with an exemplary embodiment of the present invention. The method 700 may be used by the capacitance sensing circuit 500. The method 400 may start with step 402. At step 402, the method 400 configures an electrical circuit (e.g., a driving circuit) to drive a load circuit (e.g., a load device) with an amplifier. The amplifier may be, for example, a voltage output amplifier. As shown in FIG. 5, an exemplary embodiment may use the amplifier 502 to drive an external load device. The load device may be a motor with a capacitance C_{OUT} . The load device may be coupled to the output pin 510, which is electrically connected to output of the amplifier 502 via a switch 522. Next, at step 704, the method 700 may load an input of the amplifier at a desired voltage V to perform capacitance sensing. In one or more embodiments, the capacitance of the load circuit C_{OUT} may vary with the applied voltage, thus, the capacitance sensing may be performed at or about the desired voltage.

[35] From step 704, the method 700 may proceed to step 706. At step 706, the method 700 may disconnect the output pin 510 from the amplifier 502 and connect the output pin 510 to the current source 512. Thus, in FIG. 5, the switch 522 may be disconnected, switch 524 may be connected, and the current source 512 may start to charge the load circuit at the output pin 510 with a constant charge current I_{CHARGE} . Next, the method may proceed to step 508. At step 508, the method 700 may generate a fast voltage change $+\Delta V_1$ at the input of the comparator 504 (e.g., the reference voltage V_{REF} is set to $V + \Delta V_1$). But, as the switch 522 is disconnected, the output voltage $V_{OUT'}$ from the amplifier 502 will not affect the charge rate for the output pin 510. Next, the method 700 may proceed to step 710. At step 710, the method 700 may measure the time T_{CHARGE} it takes for the voltage at the output pin 510 to reach the reference voltage V_{REF} (e.g., $V + \Delta V_1$ in FIG. 6(a)). For

example, the comparator 504 may control the counter 508 to count the charge time period between t_1 and t_2 .

- [36]** At step 712, the capacitance C_{OUT} of the load device may be determined. For example, based the voltage change ΔV_1 of the reference voltage V_{REF} , and the capacitance C_{OUT} may be calculated as follows:

$$C_{OUT} = \frac{I_{CHARGE}}{\Delta V_1} \cdot (t_2 - t_1).$$

- [37]** In one or more embodiments, a current source (e.g., current source 112, or current source 512) may be a current sink and the capacitance C_{OUT} at the output pin may be calculated (e.g., estimated) by a discharge current $I_{DISCHARGE}$. That is, a current sink (e.g., a current drain) may be coupled to the output pin to drain electrical charges from the output pin (e.g., a load coupled thereon) to ground. With a discharge current $I_{DISCHARGE}$, the voltage changes ΔV s as discussed above may be negative changes (e.g., decreases instead of increases). Triggering of the amplifiers and comparators may be similar but the discharging slope for the output voltage V_{OUT} may be a decline slope instead of a rising slope, and the counter may count time similarly by using reference voltages to start and/or stop, as for charging periods. The capacitance may be calculated using the absolute value of the voltage changes. For example, if no offset voltage is used, the capacitance may be calculated as follows:

$$C_{OUT} (V) = \frac{I_{DISCHARGE}}{|\Delta V|} \cdot T_{DISCHARGE} (V).$$

- [38]** Those skilled in the art may appreciate from the foregoing description that the present invention may be implemented in a variety of forms, and that the various embodiments may be implemented alone or in combination. Therefore, while the embodiments of the present invention have been described in connection with particular examples thereof, the true scope of the embodiments and/or methods of the present invention should not be so limited since other modifications will become apparent to the skilled practitioner upon a study of the drawings, specification, and following claims.

WE CLAIM:

- 1.** A method for testing capacitance of a load circuit connected to an output pin of a driving circuit, comprising:

 - driving a voltage at the output pin to a first voltage;
 - applying a predetermined current to the output pin;
 - comparing the voltage at the output pin to a reference voltage; and
 - when the voltage at the output pin matches the reference voltage, generating an estimate of capacitance present at the output pin based on a number of clock cycles occurring between an onset of a timed voltage change period and a time at which the voltage at the output pin matches the reference voltage.
- 2.** The method of claim 1, wherein the capacitance varies based upon the voltage at the output pin and the first voltage is a desired voltage for the load circuit.
- 3.** The method of claim 1, wherein comparing the voltage is performed by a comparator with a first input coupled to the output pin and a second input coupled to the reference voltage.
- 4.** The method of claim 3, wherein the load circuit includes a motor and the output pin is driven to the first voltage by a voltage output amplifier, the voltage output amplifier outputs control signals from a digital-to-analog converter.
- 5.** The method of claim 4, wherein a current source is provided in the voltage output amplifier and connected to the output pin in a current-limited mode.
- 6.** The method of claim 5, wherein the onset of the timed voltage change period is triggered by a sudden voltage change at an input of the voltage output amplifier.
- 7.** The method of claim 6, wherein the output pin is coupled to an input of the comparator via an offset voltage and the reference voltage is equal to the first voltage and the sudden voltage change combined.
- 8.** The method of claim 5, wherein the timed voltage change period starts when the voltage at the output pin matches to a first value of the reference voltage after a sudden voltage change at an input of the voltage output amplifier and ends when the voltage at the output pin matches to a second value of the reference voltage, the first value of the reference voltage is less than the second value of the reference voltage, and the second

value of the reference voltage is less than the first voltage and the sudden voltage change combined.

9. The method of claim 4, wherein a current source is provided separate from the voltage output amplifier.

10. The method of claim 9, wherein the onset of the timed voltage change period is triggered by connecting the current source to the output pin, the reference voltage is equal to the first voltage and the voltage change combined.

11. The method of claim 1, wherein the predetermined current is a charge current and the output pin is charged during the timed voltage change period.

12. The method of claim 1, wherein the predetermined current is a sink current and the output pin is discharged during the timed voltage change period.

13. A system for testing capacitance of a load circuit coupled to an output pin of an electrical circuit, comprising:

a driving amplifier having an output coupled to the output pin, wherein a first input of the amplifier is coupled to an input signal and a second input of the amplifier is coupled to the output of the amplifier;

a current source selectively coupled to the output pin, the current source to apply a current to the output pin during a testing period;

a comparator having inputs coupled to the output pin and to a reference voltage;
and

decision logic coupled to an output of the comparator, to determine capacitance present at the output pin based on a response of time of the voltage at the output pin.

14. The system of claim 13, wherein the decision logic includes a counter.

15. The system of claim 14, wherein the counter counts a timed voltage change period for the output pin to match the reference voltage, and the decision logic uses the timed voltage change period, the charge current and rate of charge to determine the capacitance of the load circuit coupled to the output pin.

16. The system of claim 15, wherein the reference voltage is provided by the input signal, and the output pin is coupled to the comparator via an offset voltage.

- 17.** The system of claim 16, wherein the timed voltage change period is determined by starting the counter when a step change is applied to the input signal and stopping the counter when the voltage at the output pin reaches the reference voltage minus the offset voltage.
- 18.** The system of claim 15, wherein the timed voltage change period is determined by starting the counter when the voltage at the output reaches a first value of the reference voltage after a step change is applied to the input signal, and stopping the counter when the voltage at the output pin reaches a second value of the reference voltage.
- 19.** The system of claim 13, wherein the amplifier is a voltage output amplifier, the load circuit includes a motor and the amplifier outputs control signals for the motor from a digital to analog converter.
- 20.** The system of claim 13, wherein the capacitance of the external circuit varies with the voltage at the output pin.
- 21.** The system of claim 13, wherein the current is a charge current and the output pin is charged during the timed voltage change period.
- 22.** The system of claim 13, wherein the current is a sink current and the output pin is discharged during the timed voltage change period.
- 23.** A system for testing capacitance of a load circuit coupled to an output pin of an electrical circuit, comprising:
- a first and second electrical switches;
 - a driving amplifier having an output coupled to the output pin via the first switch, wherein a first input of the amplifier is coupled to an input signal and a second input of the amplifier is coupled to the output of the amplifier;
 - a current source selectively coupled to the output pin via the second switch, the current source to apply a current to the output pin during a testing period;
 - a comparator having inputs coupled to the output pin and to a reference voltage;
- and
- decision logic coupled to an output of the comparator, to determine capacitance present at the output pin based on a response of time of the voltage at the output pin.
- 24.** The system of claim 23, wherein the decision logic includes a counter, the counter counts a timed voltage change period for the output pin to be charged from a desired

voltage for the output pin to the reference voltage, and the decision logic uses the timed voltage change period, the current and rate of change to determine the capacitance of the load circuit coupled to the output pin.

25. The system of claim 24, wherein the timed voltage change period is determined by starting the timer when the second switch is connected and stopping the timer when the voltage at the output pin reaches the reference voltage.

26. The system of claim 23, wherein the amplifier is a voltage output amplifier, the load circuit includes a motor and the amplifier outputs control signals for the motor from a digital to analog converter.

27. The system of claim 23, wherein the capacitance of the load circuit varies with the voltage at the output pin.

28. The system of claim 23, wherein the current is a discharge current and the output pin is discharged during the timed voltage change period.

29. The system of claim 23, wherein the current is a charge current and the output pin is charged during the timed voltage change period.

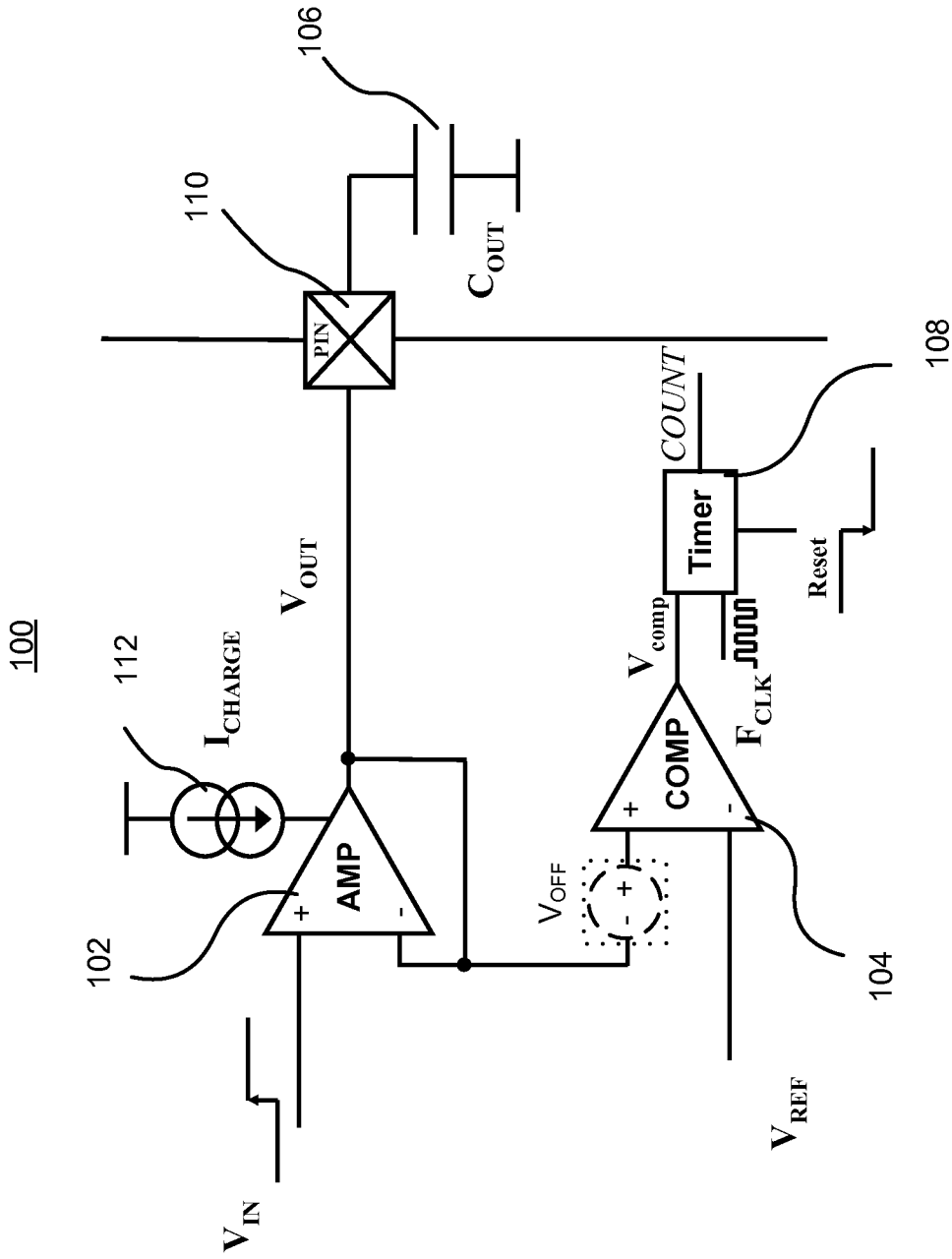

FIG. 1A

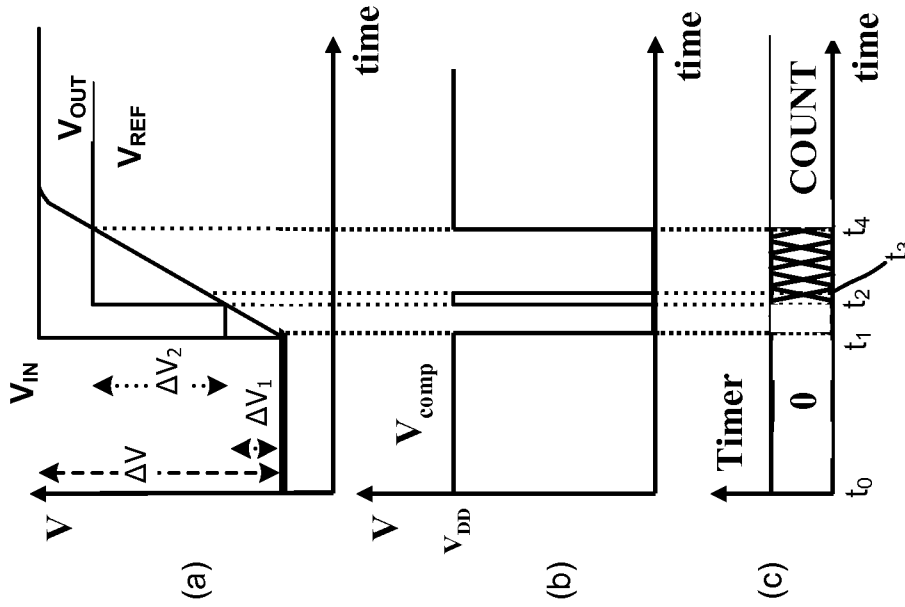

FIG. 3

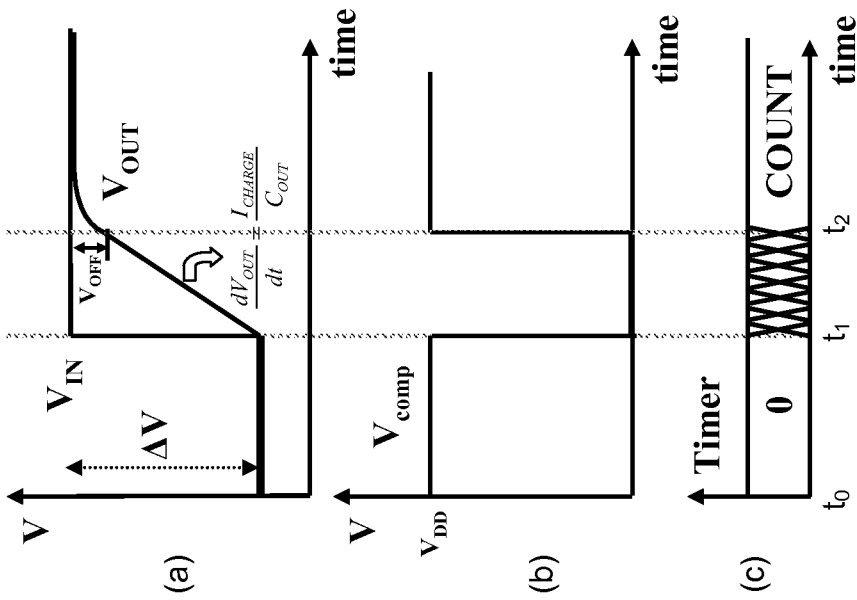

FIG. 2

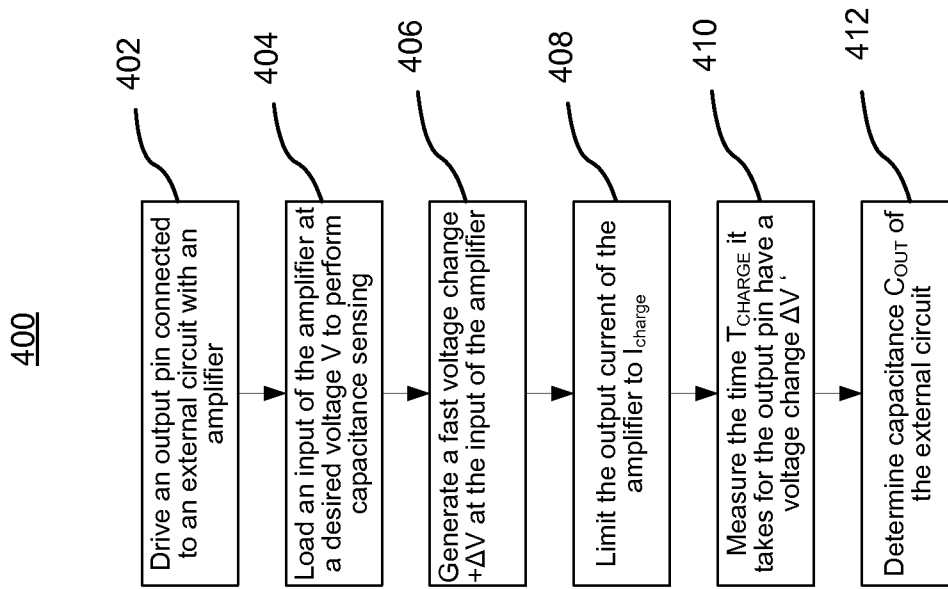

FIG. 4

500

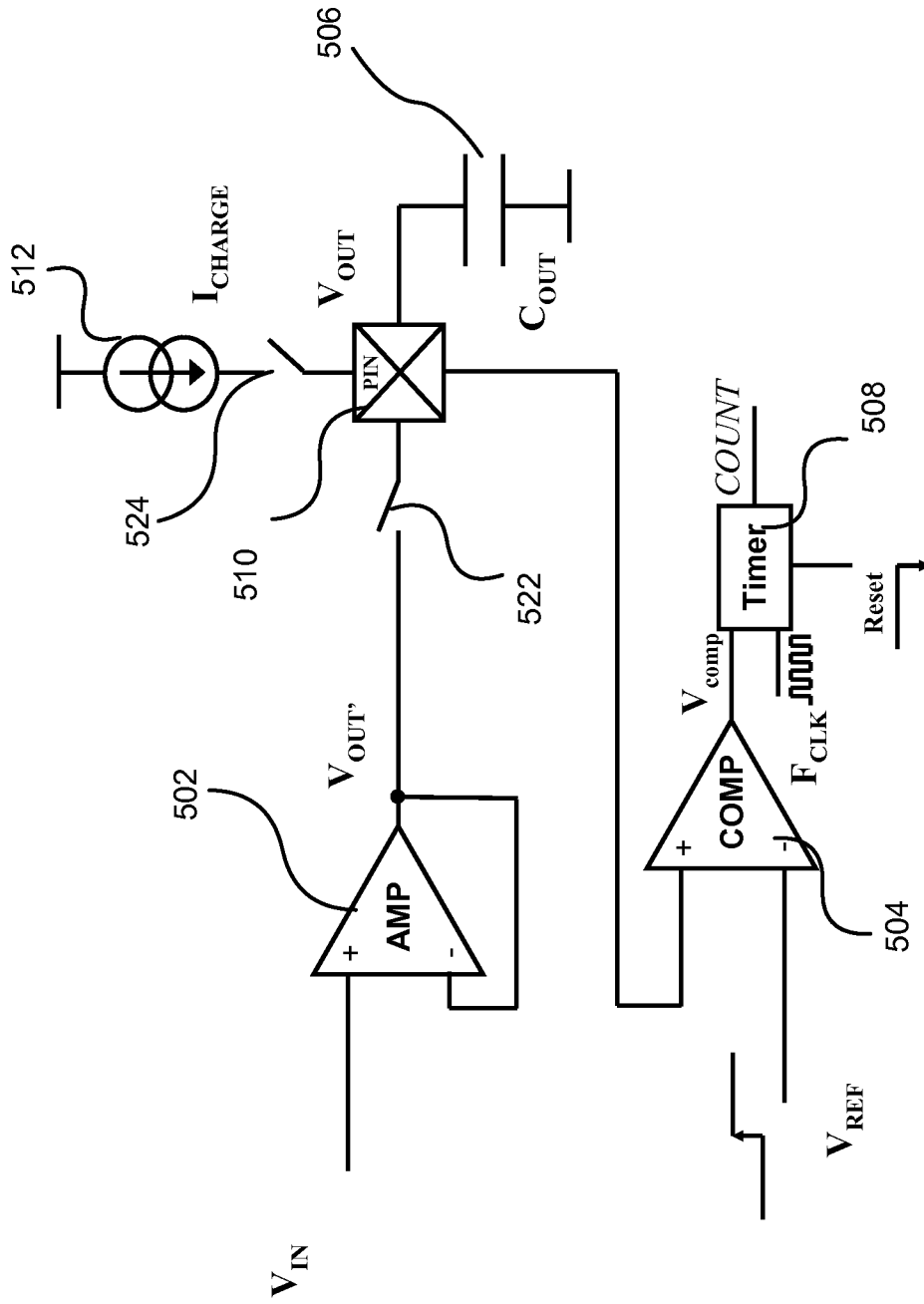

FIG. 5

700

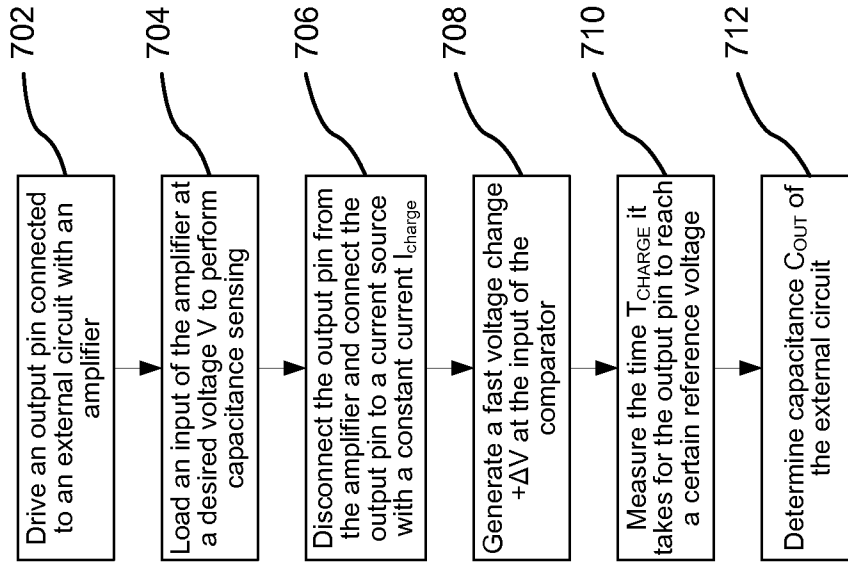

FIG. 7

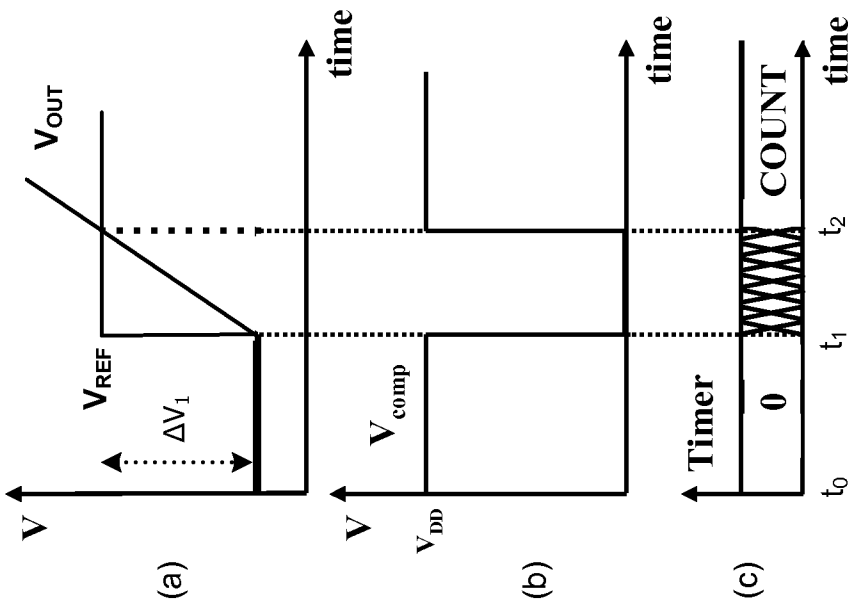

FIG. 6

INTERNATIONAL SEARCH REPORT

International application No.

PCT/US2010/046919

A. CLASSIFICATION OF SUBJECT MATTER IPC(8) - G01R 27/26 (2010.01) USPC - 324/678 According to International Patent Classification (IPC) or to both national classification and IPC		
B. FIELDS SEARCHED Minimum documentation searched (classification system followed by classification symbols) IPC(8) - G01R 1/06; G01R 27/26; G01R 31/28 (2010.01) USPC - 324/519, 537, 678 Documentation searched other than minimum documentation to the extent that such documents are included in the fields searched Electronic data base consulted during the international search (name of data base and, where practicable, search terms used) PatBase, Google Patents, Google Scholar		
C. DOCUMENTS CONSIDERED TO BE RELEVANT		
Category*	Citation of document, with indication, where appropriate, of the relevant passages	Relevant to claim No.
X — Y	US 5,576,628 A (CALIBOSO et al) 19 November 1996 (19.11.1996) entire document	1-3, 11 —
Y	US 2008/0191713 A1 (HAUER et al) 14 August 2008 (14.08.2008) entire document	4-10, 12-29
Y	US 2003/0173989 A1 (REARICK et al) 18 September 2003 (18.09.2003) entire document	4-10, 13-29
Y		12, 22, 28
<input type="checkbox"/> Further documents are listed in the continuation of Box C. <input type="checkbox"/>		
* Special categories of cited documents: "A" document defining the general state of the art which is not considered to be of particular relevance "E" earlier application or patent but published on or after the international filing date "L" document which may throw doubts on priority claim(s) or which is cited to establish the publication date of another citation or other special reason (as specified) "O" document referring to an oral disclosure, use, exhibition or other means "P" document published prior to the international filing date but later than the priority date claimed "T" later document published after the international filing date or priority date and not in conflict with the application but cited to understand the principle or theory underlying the invention "X" document of particular relevance; the claimed invention cannot be considered novel or cannot be considered to involve an inventive step when the document is taken alone "Y" document of particular relevance; the claimed invention cannot be considered to involve an inventive step when the document is combined with one or more other such documents, such combination being obvious to a person skilled in the art "&" document member of the same patent family		
Date of the actual completion of the international search 15 October 2010		Date of mailing of the international search report 21 OCT 2010
Name and mailing address of the ISA/US Mail Stop PCT, Attn: ISA/US, Commissioner for Patents P.O. Box 1450, Alexandria, Virginia 22313-1450 Facsimile No. 571-273-3201		Authorized officer: Blaine R. Copenheaver PCT Helpdesk: 571-272-4300 PCT OSP: 571-272-7774