

H. C. FUHRMAN.  
 MEANS FOR AUTOMATICALLY DRAINING PUMPS.  
 APPLICATION FILED MAY 16, 1911.

1,003,592.

Patented Sept. 19, 1911.

2 SHEETS—SHEET 1.

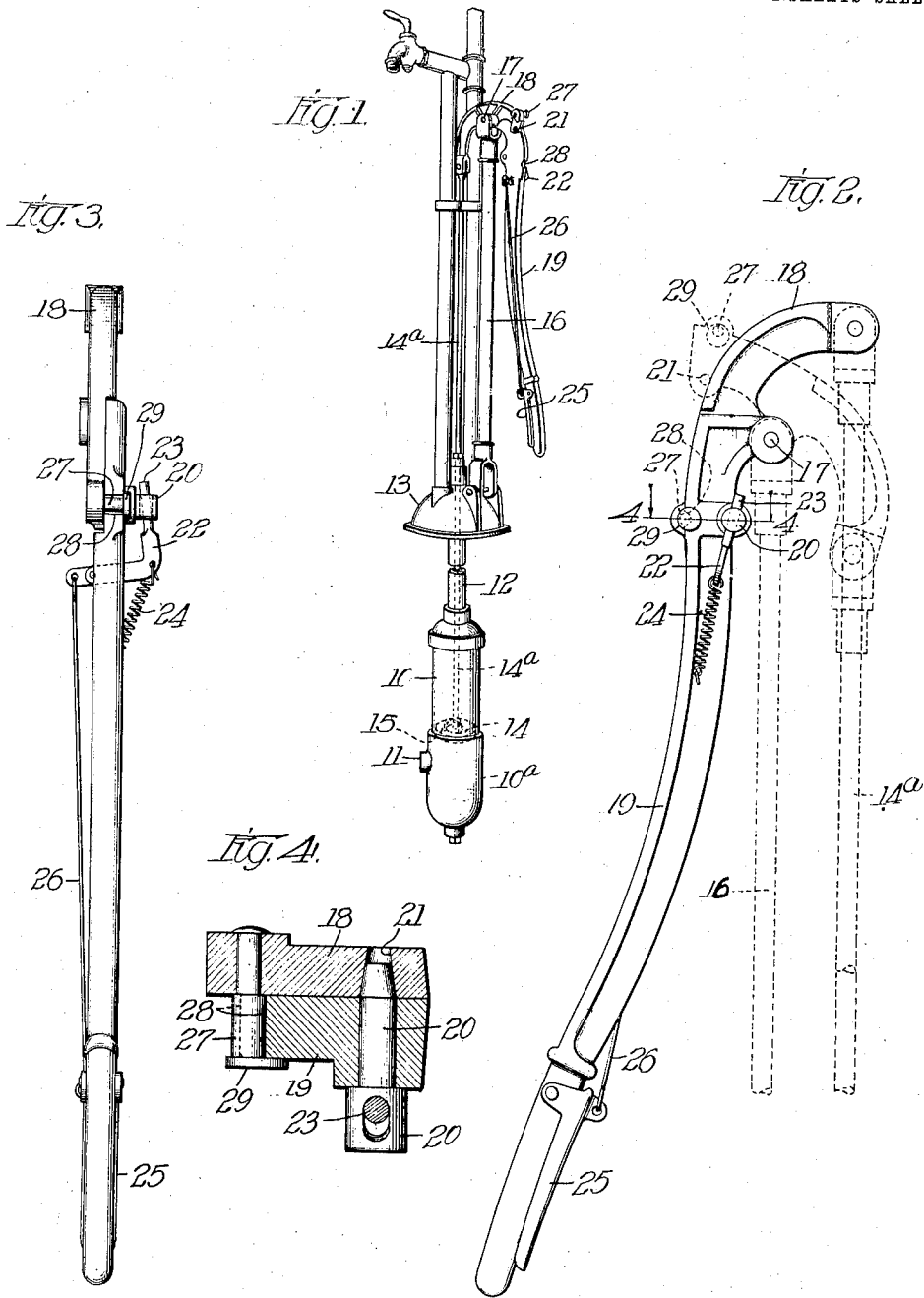

Witnesses:  
 Robert H. Weir  
 W. Perry Holm

Inventor  
 Herman C. Fuhrman  
 By James Redding, Amos S. Sibold  
 Attys.

H. C. FUHRMAN.  
 MEANS FOR AUTOMATICALLY DRAINING PUMPS.  
 APPLICATION FILED MAY 16, 1911.

1,003,592.

Patented Sept. 19, 1911.

2 SHEETS—SHEET 2.

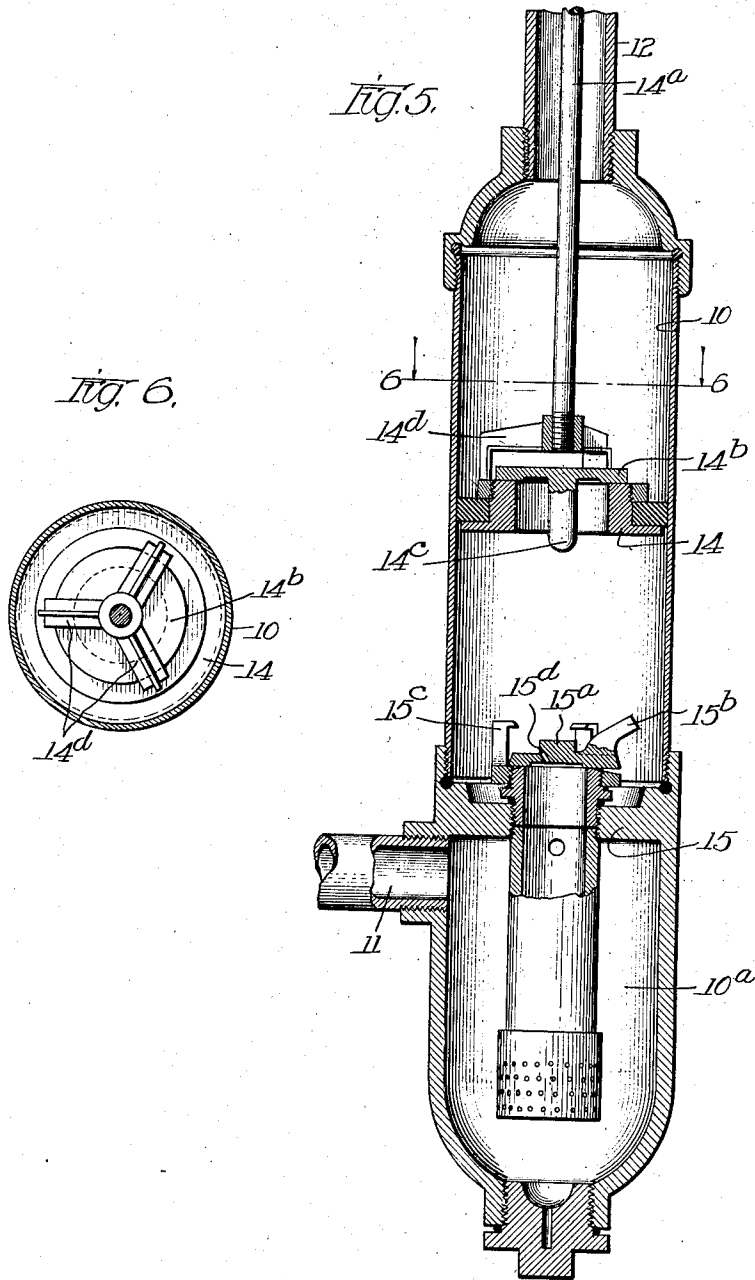

Witnesses:  
 Robert N. Veir  
 W. Perry Haley

Inventor:  
 Herman C. Fuhrman  
 By James Addington, Amos Subold  
 Attys.

# UNITED STATES PATENT OFFICE.

HERMAN C. FUHRMAN, OF CEDAR RAPIDS, IOWA, ASSIGNOR TO THE TOKHEIM MFG. CO., OF CEDAR RAPIDS, IOWA, A CORPORATION OF IOWA.

MEANS FOR AUTOMATICALLY DRAINING PUMPS.

1,003,592.

Specification of Letters Patent. Patented Sept. 19, 1911.

Application filed May 16, 1911. Serial No. 627,573.

*To all whom it may concern.*

Be it known that I, HERMAN C. FUHRMAN, a citizen of the United States, residing at Cedar Rapids, in the county of Linn and State of Iowa, have invented new and useful Improvements in Means for Automatically Draining Pumps, of which the following is a full, clear, concise, and exact description, reference being had to the accompanying drawing, forming a part of this specification.

My invention relates to means for automatically draining pumps and pertains especially to piston pumps of the kind described, for instance, in Patent No. 907,653, granted December 22nd, 1903, to the Tokheim Manufacturing Company, of Cedar Rapids, Iowa. In pumps of this type, the cylinder is arranged vertically, and the construction is such that the valves of the pump will be automatically opened when the piston is in its lowermost position. When the valves are thus opened, the liquid in the pump cylinder, in the inlet pipe, or pipes, of the pump, and in the various supply pipes running to different parts of the building, can drain back into the liquid reservoir,—leaving the pump, the inlet, and in fact the entire supply system pipes empty except for a small quantity of liquid left in the pump for priming purposes. When the pump is used for pumping gasoline, this drain-back feature is of great importance, since it insures that no substantial amount of the explosive liquid shall remain in the pump, or in the supply system of pipes,—thus minimizing the danger of fire or explosion. In pumps of this character as hitherto constructed, it has been necessary to raise the handle of the pump as soon as the pumping operation has been completed, so as to move the piston into its lowermost position (in which the valves are opened), so that all the liquid will be drained back into the reservoir. It has been found that the operator will sometimes forget to raise the handle, the effect being that the liquid is not drained back, or, at any rate, not entirely drained back—a condition which it is particularly desirable to avoid.

It is the principal object of the present invention to remedy this drawback by rendering the return of the piston to its lowermost position automatic, and not dependent upon the whim of the operator.

It is a further object of the invention to effect the above object in a convenient and simple manner.

I have described an embodiment of my invention in the following specification, and shown it in the accompanying drawings. It is to be understood, however, that changes may be made in the construction shown, without exceeding the scope of my invention, as defined in the appended claims; similarly, the invention may be embodied in other constructions.

In the drawings: Figure 1 is a perspective view of a pump constructed in accordance with my invention; Fig. 2 is a side view of the piston-operating arm and the handle for actuating the same, showing the sides of these parts opposite to those seen in Fig. 1; Fig. 3 is a rear elevation of the piston-operating arm and the actuating handle therefor; Fig. 4 is an enlarged detail sectional view, the section being taken on the line 4—4 of Fig. 2, looking in the direction of the arrows; Fig. 5 is a sectional elevation of the pump cylinder, showing the inter-engaging valves; and Fig. 6 is a sectional plan of the cylinder, the section being taken on the line 6—6 of Fig. 5.

Referring to Figs. 1, 5 and 6 of the drawings, 10 indicates the pump cylinder, having an inlet pipe 11 and an outlet pipe 12. The outlet pipe 12 is connected with a casing 13, which supports the delivery pipes, etc., of the pump. The piston of the pump is designated 14; it has secured thereto the piston stem 14<sup>a</sup>, which passes vertically upward through the outlet pipe 12, and out through a stuffing box in the casing 13. The cylinder 10 is divided into two parts by a partition 15, the part below the partition constituting a priming chamber 10<sup>a</sup>, into which the inlet pipe 11 enters. The partition 15 is provided with a trip valve 15<sup>a</sup> having an actuating arm 15<sup>b</sup>, the valve being guided in a suitable cage 15<sup>c</sup>. The piston 14 is provided with a puppet valve 14<sup>b</sup> having a downwardly extending foot 14<sup>c</sup>, the valve being guided in a suitable cage 14<sup>d</sup> carried by the piston. When the piston is moved into its lowermost position, it will engage the arm 15<sup>b</sup> and lift the trip valve 15<sup>a</sup>; and the trip valve will engage the foot 14<sup>c</sup> of the puppet valve 14<sup>b</sup> and lift the latter. When, therefore, the piston is in its lowermost position, the valves 14<sup>b</sup> and 15<sup>a</sup> are

opened, and the liquid in the pump and the pipes is thereby enabled to drain back into the liquid reservoir,—with the exception of a small quantity of liquid left in the priming chamber 10<sup>a</sup>. The pump, as outlined  
 5 above, is substantially the same as that described in Patent No. 907,653 referred to above; and no claim is made to these parts in themselves: there is not any necessity,  
 10 therefore, to enter into a more detailed description of them than has been given.

In attaining the object of my invention, I provide means for insuring that the piston shall return to its lowermost position as  
 15 soon as the operator has ceased using the pump; by this means the draining back of the liquid in the pump is automatically taken care of. In the construction illustrated, I effect this by providing the piston stem of the pump with an actuating  
 20 arm which is capable of being connected with the pump handle, but which is automatically disconnected therefrom as soon as the operator ceases using the pump. When  
 25 the actuating arm is disconnected from the handle, the piston descends by its own weight, and the pump valves are thus opened. The handle hangs vertically beside the pump when the latter is not being  
 30 used.

Mounted upon the casing 13, is a standard 16 having the upper end thereof forked to receive a pin 17. The piston actuating  
 35 arm 18 is rockably mounted, between its ends, upon the pin 17 and is pivoted to the upper end of the piston stem 14<sup>a</sup>. When the pump is not being used, the arm 18 takes the position shown in Fig. 1, and in dotted  
 40 lines in Fig. 2,—in which the piston is in its lowermost position. The pump handle 19 is also rockably mounted upon the pin 17, close beside the arm 18 but independently thereof, and hangs vertically downward as shown in Fig. 1. When it is desired  
 45 to operate the pump, the handle 19 is connected with the arm 18; so that both of these members may be rocked together about the pin 17, the pump being thereby operated. The connection between the handle  
 50 19 and the arm 18 is effected by means of a transverse latch pin 20, which is mounted in a hole in the handle 19 located opposite the adjacent end of the arm 18. The latch pin 20 is movable into and out of a  
 55 corresponding hole 21 in the arm 18, this movement being effected by a latch lever 22 pivoted to the handle, the end 23 of which enters a hole in the pin 20. The latch lever 22 is normally held back, in the position in  
 60 which the latch pin 20 is out of engagement with the hole 21 of the arm 18, by a retractile spring 24 connected at one end to the latch lever and at the other end to the handle 19. The latch lever may be moved  
 65 forward, however, to cause the pin 20 to

enter, and engage in, the hole 21, this being effected by a grip lever 25 which is pivoted to the handle 19 adjacent the end thereof. The grip lever 25 is connected, by a link  
 70 26, with the latch lever; so that, upon the handle being firmly grasped and the grip lever thereby moved toward the handle, a pull will be exerted on the link 26, and the latch lever will therefore be moved against  
 75 the action of the spring 24 to cause the latch pin 20 to enter the hole 21 of the actuating arm 18. The connection between the handle 19 and the actuating arm is thus made. When the grip lever 25 is released, the  
 80 spring 24 causes the latch lever 22 to resume its normal position, the latch pin 20 being thereby moved out of the hole 21, and the handle 19 being disconnected from the actuating arm 18. In order to facilitate the  
 85 connection of the handle with the actuating arm, the latter is provided with a stop pin 27, which extends transversely therefrom into the path of the end of the handle. The handle 19 is formed with a notch 28 for receiving this pin,—the notch and the stop  
 90 pin being disposed so that when the stop pin engages in the notch the latch pin 20 will be in position opposite the hole 21 of the actuating arm. The stop pin 27 is formed with an enlarged head 29, which  
 95 engages over the farther side of the handle 19 and thus prevents lateral movement between the handle and the actuating arm.

The actuating arm 18 and the handle 19 normally rest in the positions shown in Fig. 1, the piston being then in its lowermost position, in which the valves of the pump are open. When it is desired to operate the pump, the handle is swung upward about the pin 17 until it engages, with the notch 28,  
 100 against the pin 27 of the actuating arm,—whereupon the handle can not be moved farther in an upward direction. When the handle has been moved into this position, a grip is exerted upon the grip lever 25, with  
 105 the result that the latch pin 20, actuated by the latch lever 22, is made to enter the hole 21 of the actuating arm 18, the handle being thus connected with the actuating arm. The handle 19 may now be rocked up and down  
 110 to operate the pump, a continuous pressure being exerted upon the grip lever 25 in order to maintain the connection between the handle and the actuating lever. When a sufficient quantity of liquid has been pumped, the grip  
 120 lever 25 is released, and the handle allowed to hang in a vertical position. If the piston does not happen to be in its lowermost position at the time when the connection between the handle and the actuating arm 18 is broken  
 125 by the releasing of the grip lever 25, the piston will descend by its own weight, carrying with it the end of the actuating arm. The parts will then remain in the positions shown in Fig. 1, the pump valves being open and 130

the liquid in the pump and in the supply pipes being therefore enabled to drain back to the liquid reservoir.

It has been found that under certain circumstances the weight of the oil above the piston 14 is not sufficient to cause the piston to descend with sufficient force to cause the valves 14<sup>b</sup> and 15<sup>a</sup> to be opened. I therefore provide in the valve 15<sup>a</sup> a small opening 15<sup>d</sup>, which while not injuriously affecting the pumping action, will permit the oil remaining between the piston 14 and partition 15, when the pumping is stopped, to drain back into the priming chamber 10<sup>a</sup>. This creates a vacuum between the piston 14 and partition 15 which forcibly draws the piston down, opening the valves 14<sup>b</sup> and 15<sup>a</sup>. In some cases, especially when the pump is placed at a level which is only slightly above the level of the liquid reservoir, it may be necessary to provide the piston 14 with one or more follower weights, or to increase the weight of the piston itself, so as to make certain that the piston will descend.

The faucet key of the pump may be provided with a small air opening to permit air to enter the cylinder during the downward movement of the piston. If desired, an air inlet valve, suitably placed, may be used instead of the opening in the faucet key.

It will be seen that this construction renders the return of the pump piston to its lowermost position entirely outside of the control of the operator of the pump. The piston necessarily returns to this position as soon as the pump handle is released. The result of this is that the draining back of the liquid contained in the pump and the supply pipes is definitely insured. The construction is simple and may be economically produced; moreover, the pump is equally easy to operate as though an ordinary handle connected directly with the piston stem, were employed.

Having thus described my invention, what I claim as new, and desire to secure by Letters Patent, is:

1. The combination with a pump piston arranged to return, after being operated, to a predetermined position, of means for operating said piston, said operating means comprising an actuating member directly connected with said piston, a handle adapted to be detachably connected with said actuating member so as to communicate its movements to the same, manually operable means for making and maintaining connection between said handle and said actuating member, and means for maintaining said handle and said actuating member out of connection with each other except when said handle is being operated, for the purposes set forth.

2. The combination with a pump piston arranged to return, after being operated, to a predetermined position, of means for oper-

ating said piston, said operating means comprising an actuating member directly connected with said piston, a handle adapted to be connected with said actuating member so as to communicate its movements to the same, manually operable means for connecting said handle with said actuating member, and automatic means for releasing said locking means, for the purposes set forth.

3. The combination with a pump piston arranged to return, after being operated, to a predetermined position, of means for operating said piston, said operating means comprising an actuating member directly connected with said piston, a handle adapted to be connected with said actuating member so as to communicate its movements to the same, manually operable means for connecting said handle with said actuating member, and a spring for releasing said locking means, for the purposes set forth.

4. The combination with a pump piston arranged to return, after being operated, to a predetermined position of means for operating said piston, and means comprising a pivoted member directly connected with said piston, a handle pivoted coaxially with said member and located adjacent said member, manually operable means for connecting said handle with said member, and means for automatically disconnecting said handle from said member, for the purposes set forth.

5. The combination with a vertically disposed piston pump, of means for operating the piston of said pump, said operating means comprising a pivoted member directly connected with the piston of said pump, a handle pivoted coaxially with said member and located adjacent thereto, a manually operable latch carried by said handle and adapted to connect said handle with said member, and automatic means for releasing said latch, for the purposes set forth.

6. The combination with a vertically disposed piston pump, having a handle-supporting standard; of an arm pivoted to said standard; a handle pivoted to said standard coaxially with said arm; a spring-released latch carried by said handle, said latch being adapted, when operated, to effect a connection between said handle and said arm; and actuated means for operating said latch; and interengaging means between said handle and said arm, for enabling said handle to be correctly positioned with respect to said arm to allow said latch to connect said handle with said arm, for the purposes set forth.

7. The combination with a pump including a vertically arranged cylinder having an inlet valve therein, and a piston having an outlet valve therein, said valves being disposed so as to interengage and be open when the piston is in its lowermost position, and said piston being adapted to fall by gravity to cause the interengagement and opening of

the valves, of means for operating the piston of the pump, said operating means comprising an actuating member directly connected with the piston rod, a handle adapted to be  
5 detachably connected with said actuating member so as to communicate its movement thereto, and means for detachably connecting said handle with said actuating member.

8. The combination with a pump including a vertically arranged cylinder having an inlet valve therein and having a by-pass arranged around said valve, and a piston having an outlet valve therein, said valves being disposed so as to be open when the  
10 piston is in its lowermost position, said piston being adapted to fall by gravity to cause the opening of said valves, of means for operating the piston of the pump, said operating means comprising an actuating  
15 member directly connected with the piston rod, a handle adapted to be detachably connected with said actuating member, and means for detachably connecting said handle with said actuating member.

9. In a pump, the combination with a vertically arranged cylinder, of a piston operating therein, an operating handle for said piston, means for automatically disconnecting said piston from said handle when the  
20 operator ceases pumping, an outlet valve in said piston, an inlet valve arranged in said cylinder, said inlet and outlet valves being arranged to be opened by the descent of said piston, and means whereby a vacuum will  
25 be created beneath said piston when the operator ceases pumping to cause said piston to forcibly descend.

10. In a pump, the combination with a vertically arranged cylinder, of a piston operating therein, an operating handle for said piston, means for automatically disconnecting said piston from said handle when the  
30 operator ceases pumping, an outlet valve in said piston, an inlet valve in said cylinder, said inlet and outlet valves being arranged to be opened by the descent of said piston,  
35 said inlet and outlet valves being arranged to be opened by the descent of said piston,

and means for draining the fluid left beneath said piston in said cylinder when the operator ceases pumping, whereby a vacuum will be created beneath said piston and cause  
50 the piston to forcibly descend.

11. In a pump, the combination with a vertically arranged cylinder, of a piston operating therein, an operating handle for said piston, means for automatically disconnecting  
55 said piston from said handle when the operator ceases pumping, an outlet valve in said piston, an inlet valve in said cylinder, said outlet and inlet valves being arranged to be opened by the descent of said piston,  
60 and a by-pass in said inlet valve to permit the fluid remaining in said cylinder beneath said piston to drain therefrom and thereby create a vacuum beneath the piston to cause the piston to forcibly descend.

12. In a pump, the combination with a vertically arranged cylinder having a priming chamber arranged beneath the same, of a piston operating in said cylinder, an operating handle for said piston, means for auto-  
65 matically disconnecting said piston from said handle when the operator ceases pumping, an outlet valve in said piston, an inlet valve arranged between said cylinder and priming chamber, said outlet and inlet valves  
70 being arranged to be opened by the descent of said piston, a by-pass in said inlet valve leading from said priming chamber to said cylinder to permit the fluid remaining in said cylinder beneath said piston when the  
75 operator ceases pumping to drain into said priming chamber and create a vacuum beneath the piston to cause the piston to forcibly descend.

In witness whereof, I have hereunto sub-  
85 scribed my name in the presence of two witnesses.

HERMAN C. FUHRMAN.

Witnesses:

THOS. B. POWELL,  
WILLIAM H. DUTTON.