

June 19, 1923.

1,459,676

F. KIRSTEN

GRINDING OR SHARPENING DEVICE FOR RAZOR BLADES

Filed Aug. 11, 1920

3 Sheets-Sheet 1

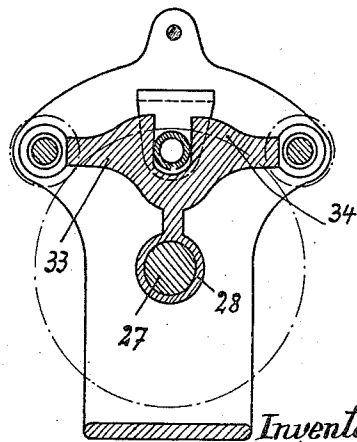
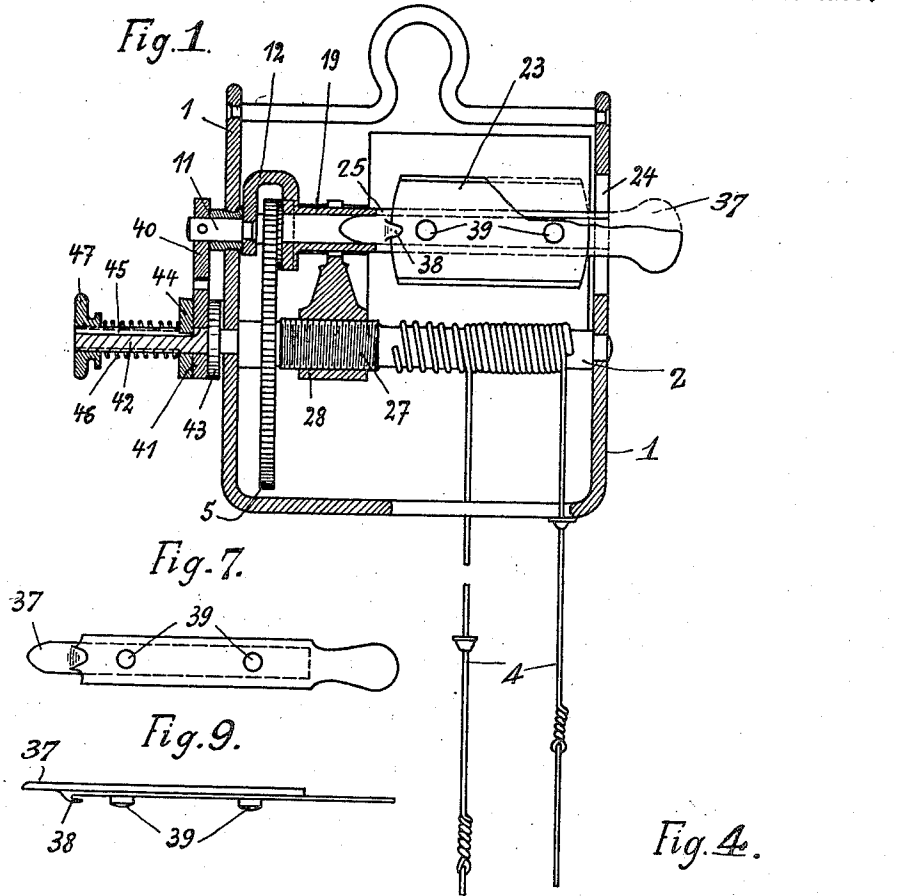

Inventor
F. Kirsten
by Wilkinson & Niusta
Attorneys

June 19, 1923.

1,459,676

F. KIRSTEN

GRINDING OR SHARPENING DEVICE FOR RAZOR BLADES

Filed Aug. 11, 1920

3 Sheets-Sheet 2

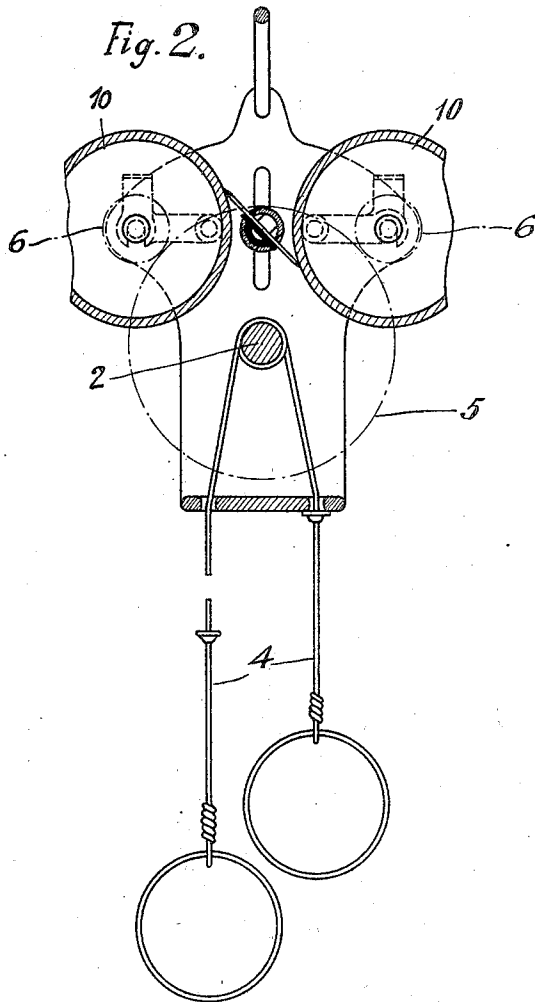

Inventor
F. Kirsten
by Wilkinson & Husta
Attorneys

June 19, 1923.

1,459,676

F. KIRSTEN

GRINDING OR SHARPENING DEVICE FOR RAZOR BLADES

Filed Aug. 11, 1920

3 Sheets-Sheet 3

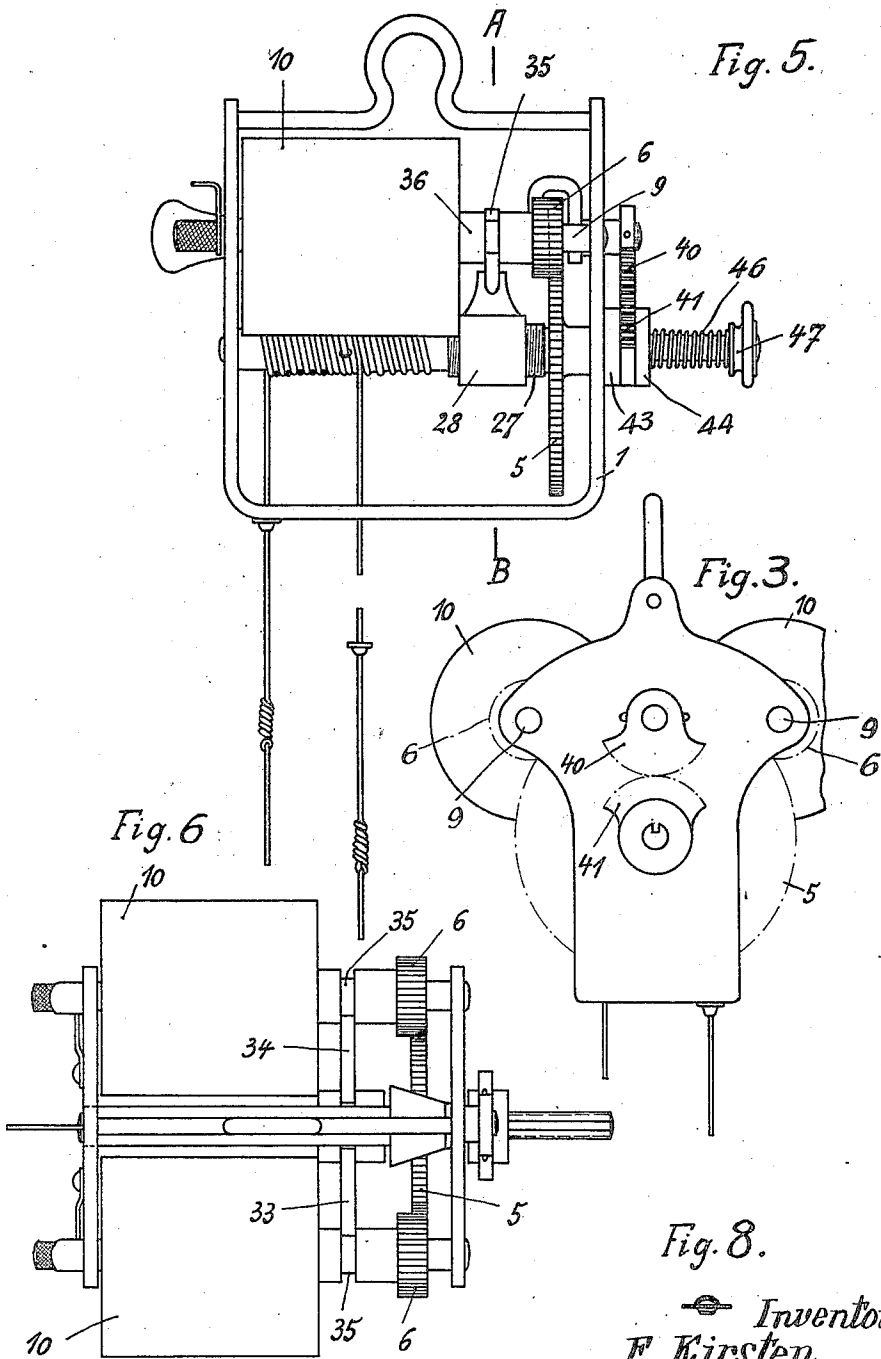

 Inventor
F. Kirsten
by Wilkinson & Gustaf
Attorneys.

UNITED STATES PATENT OFFICE.

FRIEDRICH KIRSTEN, OF CELLE IN HANOVER, GERMANY.

GRINDING OR SHARPENING DEVICE FOR RAZOR BLADES.

Application filed August 11, 1920. Serial No. 402,931.

To all whom it may concern:

Be it known that FRIEDRICH KIRSTEN, a subject of the German Republic, residing Bahnhofstrasse 16, Celle in Hanover, Germany, has invented certain new and useful Improvement in Grinding or Sharpening Devices for Razor Blades, of which the following is a specification.

The present invention relates to razor blade sharpeners, and more particularly to that type embodying grinding rollers.

An object of the present invention is to generally improve the construction of such devices and to provide means for insuring a more complete and rapid grinding between the blade and roller for more quickly and evenly grinding the edge of the blade.

Briefly stated, this invention embodies the provision of an intermediate gear between the driving and driven parts of the device thereby enabling the drive of the grinding rollers to be accelerated, and the grinding rollers to be reciprocated in the direction of their longitudinal axis by the action of a travelling nut arranged on a stub shaft or roller for lateral displacement alternately in opposite directions, and moreover the blade holder to be oscillated by a friction crank or strap which acts with regulable pressure upon one of the transmission elements of the intermediate gear.

As a result of this arrangement of the device the grinding rollers which are rapidly rotated are caused during the operation to act on the edges of the blades with their whole circumference and length so that they are uniformly worn on their circumference and, in view of the regulability of the pressure of the crank, an efficient and rapid engagement thereof by the gear element is attained and the blade with its edges is forced against the circumference of the grinding rollers immediately after the commencement of the rotation. In consequence of this co-operation of the parts of the device the blades sharpened thereby receive an extremely uniform fine grinding.

The accompanying drawings illustrate a constructional form of the invention,

Figure 1 representing a vertical section,

Figure 2 a transverse section,

Figure 3 a front elevation.

Figure 4 a cross section of the latter on the line A—B of Figure 5.

Figure 5 a lateral view.

Figure 6 is a plan view and Figures 7 to 9

the blade holder in plan view, section and lateral elevation.

In a U-shaped frame 1 is journaled an axle 2 over which is wound an actuating member 4. On alternately pulling the ends of said member 4, the axle 2 is caused to rotate rapidly in the one or the other direction. Connected with the axle 2 is the large gear wheel 5 which latter engages with two gear wheels 6 mounted on hollow shafts 36 adapted to be displaceable on axles 9 journaled in the frame 1. The gear wheels 6 have the double breadth of the gear wheel 5. The hollow shafts 36 are also provided with grinding rolls 10 consisting of suitable material such as leather, wood, stone or the like, and adapted to be interchangeable.

The travelling nut 28 on the threaded portion 27 of the axle 2 is provided with two lateral arms 33, 34 adapted to engage with grooves 35 in the hollow shafts 36. Instead of said grooves the hollow shafts may be provided with discs adapted to engage in slots at the ends of the arms 33, 34.

The blade holder (Figs. 7 to 9) consists of a strip 37 having a projection 38 and two pins 39. The razor blade is secured by sliding its one end beneath the projection 38 and placing its holes over the pins 39. A slot 24 provided in the frame 1 enables the insertion of the blade holder and blade into the device.

A tube 19 provided with a longitudinal slot 25 is situated between the rolls 10 and journaled at one end in the frame 1, the other end extends into a strap 12 having a trunnion 11 journaled in the frame 1, and carrying a toothed sector 40 which engages with another toothed sector 41. The sector 41 is loosely mounted between a disc 43, on the free end 42 of the axle 2, and a disc 44. The disc 44 is slidable upon 42 by means of a lug engaging with a groove 45 and under the influence of a spring 46 controlled by the nut 47 in order to adjust the friction between the sector 41 and the discs 43, 44.

The method of working is as follows:—

The blade holder 37 with the razor blade 23 is inserted through slot 24 into the slot 25 of the tube 19, by pulling the actuating members 4 the axle 2, as well as the gear wheels 5, 6 are alternately rotated, the grinding rolls 10 are thereby rotated and axially displaced, by means of the arms 33, 34 which engage with the hollow shafts 36, the sectors 40, 41 cause thereby an oscillatory movement

2
of the strap 12, and thus an alternate contact of the razor blade 23 with the two grinding rolls 10.

5 What I claim and desire to protect by Letters Patent is:—

10 A razor blade sharpener, comprising a frame, a shaft in the frame, a gear on the shaft, a pair of hollow shafts mounted for axial movement in the frame, pinions on the hollow shafts meshing with said gear for rotating hollow shafts, means for turning said first shaft in opposite directions, said first shaft having a threaded portion, a sleeve mounted on the threaded portion and

having arms engaging said hollow shafts, 15 said sleeve being adapted to be reciprocated axially upon the turning of the first shaft in opposite directions to shift the hollow shafts during rotation, grinding rollers carried by the hollow shafts, and a blade holder, 20 arranged between said rollers, substantially as described.

In testimony whereof I have affixed my signature in presence of two witnesses.

FRIEDRICH KIRSTEN.

Witnesses:

ALBERT KROLIKOWSKI,
JOHANNA HUPPERTZ.