



(11) **EP 1 392 913 B1**

(12) **EUROPEAN PATENT SPECIFICATION**

(45) Date of publication and mention of the grant of the patent:
01.07.2009 Bulletin 2009/27

(51) Int Cl.:
D21C 5/00 ^(2006.01) **D21F 1/66** ^(2006.01)

(21) Application number: **02722318.9**

(86) International application number:
PCT/FI2002/000391

(22) Date of filing: **07.05.2002**

(87) International publication number:
WO 2002/090647 (14.11.2002 Gazette 2002/46)

(54) **METHOD AND APPARATUS FOR RECOVERING FIBRE AND FIBRE-BASED SOLIDS FROM A FILTRATE OF THE MECHANICAL OR CHEMI-MECHANICAL WOOD PULP INDUSTRY, SAID FILTRATE CONTAINING BOTH SOLIDS AND LIPOPHILIC EXTRACTIVE MATERIAL**

VERFAHREN UND VORRICHTUNG ZUR RÜCKGEWINNUNG VON FASERN UND FASERBASIERENDEN FESTSTOFFEN AUS EINEM FILTRAT DER MECHANISCHEN ODER CHEMOMECHANISCHEN HOLZSTOFFINDUSTRIE, WELCHES FILTRAT SOWOHL FESTSTOFFE ALS AUCH LIPOPHILES EXTRAKTMATERIAL ENTHÄLT

PROCEDE ET APPAREIL PERMETTANT DE RECUPERER DES FIBRES ET DES SOLIDES A BASE DE FIBRES A PARTIR D'UN FILTRAT DE L'INDUSTRIE MECANIQUE OU CHIMIO-MECANIQUE DES PATES, LEDIT FILTRAT CONTENANT A LA FOIS DES SOLIDES ET DES MATERIAUX D'EXTRACTION LIPOPHILES

(84) Designated Contracting States:
AT BE CH CY DE DK ES FI FR GB GR IE IT LI LU MC NL PT SE TR

(30) Priority: **09.05.2001 FI 20010967**

(43) Date of publication of application:
03.03.2004 Bulletin 2004/10

(73) Proprietor: **Andritz AG**
8045 Graz (AT)

(72) Inventors:
• **KOTONEN, Petteri**
FIN-53300 Lappeenranta (FI)
• **VÄKIPARTA, Toni**
FIN-53810 Lappeenranta (FI)

(74) Representative: **Schweitzer, Friedrich**
Stattegger Strasse 18
8045 Graz (AT)

(56) References cited:
DD-A1- 223 479 **US-A- 5 022 962**
US-A- 5 321 898 **US-A- 5 468 396**

EP 1 392 913 B1

Note: Within nine months of the publication of the mention of the grant of the European patent in the European Patent Bulletin, any person may give notice to the European Patent Office of opposition to that patent, in accordance with the Implementing Regulations. Notice of opposition shall not be deemed to have been filed until the opposition fee has been paid. (Art. 99(1) European Patent Convention).

Description

[0001] The present invention relates to a method and apparatus for recovering fibre and fibre-based solids from filtrates containing both solids and lipophilic extractive agents, i.e. extractives of the mechanical or chemi-mechanical pulp industry.

[0002] Lipophilic extractives, i.e. mainly resin from wood, cause various problems particularly in the production of pulp and paper from mechanical or chemi-mechanical pulp. The most common problems are fouling of wires and showers, and deposits at the paper machine. Lipophilic extractives and their deposits also decrease the strength and brightness properties of the paper and cause holes in the paper. Mechanical and chemi-mechanical pulp production processes mentioned are for example TMP (ThermoMechanical Pulping), CTMP (ChemiThermoMechanical Pulping), GW (Ground-Wood), PGW (Pressure GroundWood), APMP (Alkaline Peroxide Mechanical Pulping), CMP (ChemiMechanical Pulping) and other corresponding processes which at least partly are based on mechanical detachment of fibres.

[0003] Many paper mills, which have tried to reduce the use of water, have faced the problems described above. Thus, it is clear that in the future the more stringent discharge limits and the reductions in the use of water will increase the problems caused by detrimental substances in the paper manufacture. Based on studies on the subject, accumulation of lipophilic extractives in the water circulations causes one of the biggest problems in view of the reduction of water consumption. On the other hand, the interest to use wood species with higher extractives concentrations, such as pine from first felling and aspen, has been increasing all the time which further increases the need to have more efficient extractives removal methods.

[0004] In the processes used to date, the amount of extractives in the paper machine is limited by washing the pulp and using various chemicals. Both performed studies and practical experience have shown that the methods used to date are not sufficient to prevent extractives from accumulating in the circulations when water circulations are closing. This is due to the fact that the dispersion of the extractives into water is reduced when the water consumption is reduced and the extractive retention in the washers increases. Results obtained from both mill-scale measurement and various simulations indicate that the accumulation of extractives could be prevented in the future by the following methods:

1. by changing the water circulations of the pulp mill so that filtrates containing higher extractives contents can be removed from the process;
2. by replacing the present washing equipment with more efficient ones (for example screw presses);
3. by using various internal cleaning methods.

[0005] Modifying the water circulations and the use of more efficient washing equipment means in practice increasing the loss of solids multifold compared with the present situation. Modifying the water circulations alone would increase the solids loss to be even 4-5 fold compared with the present. More efficient presses in the wash of lipophilic extractives would increase the solids loss even from this up to 3-6 fold. Further, more efficient presses separate from the pulp to the water fine solids, which would have a clearly improving influence on the optic properties in the paper to be produced. Thus, if the filtrate from this press was removed from the process, the optic properties of the pulp would deteriorate. Changing the water circulations and employing more efficient presses presuppose development of more efficient fibre recovering equipment and introducing them into use.

[0006] In the following, a conventional prior art process, a PGW (Pressure Ground Wood) process, Fig. 1, is described as an example, in which the wood is introduced into the process as logs which are then ground at 2 at a high pressure to a fibre suspension. Because of the high pressure, the temperature of the fibre suspension is high, which is why the following element in the process, the thickening device 4, is called a hot loop thickener. In the thickener 4, the consistency of the fibre suspension is raised by removing from it filtrate, which is introduced into a hot water tank 6. Part of the filtrate in question is pumped from the hot water tank 6 to serve as shower water in refining while the rest flows into a channel 8 and further to the water cleaning system of the mill.

[0007] The fibre suspension thickened in the hot loop thickener 4 is then introduced into sorting 10, however, before that the suspension is diluted, 12, with liquid obtained at least partly from the process itself. From the sorting 10 the fibre suspension continues to a disc filter 14, which again removes liquid/filtrate from the suspension. Filtrates of two types are obtained from the disc filter 14 by conventional methods, i. e. a clear filtrate and a cloudy filtrate, each into its own filtrate tank 16 and 18. Sometimes also a so-called super clear filtrate is separated which practically does not contain fines at all. Usually also paper machine white water containing some fibres, fillers and other material filtered through the paper machine wire, is introduced into the cloudy filtrate tank 16, and also some filtrate from the clear filtrate tank 18 while the rest of the clear filtrate flows into the channel 8 and from there further to the water purification system of the mill. Liquid from the cloudy filtrate tank 16 is used in the dilution 12 preceding the sorting 10 as already mentioned.

[0008] From the disc filter 14 the thickened fibre suspension flows to a bleach press 20 with which the consistency of the suspension is raised to the level required by the bleaching process. Filtrate from the bleach press 20 is collected to a bleach press filtrate tank 22 and from there in most cases all of it is used in the dilution 24 preceding the disc filter 14.

EP 1 392 913 B1

The thickened fibre suspension from the bleach press 20 flows to a bleaching 26 (peroxide bleaching in the figure), which is followed by a washing press 28, which aims at removing reaction products of the bleaching from the fibre suspension. After the washing press 28 the suspension travels to the paper mill while the filtrate from the washing press 28 flows to a washing press filtrate tank 30. The filtrate collected there is used with filtrate from the bleach press 20 in the dilution 24 preceding the disc filter 14 and with fresh water in a dilution 32 preceding the washing press 28. It should be noted from the above description that the several dilution and the following pressing and thickening stages mentioned above mean in practice washing the fibre suspension whereby extractives or other substances detached from the fibres during the process and intended to be removed, are washed from the suspension.

[0009] Table I presents extractive and solids contents of various filtrates in a prior art process (Fig. 1) and Table II illustrates solids contents and extractives retentions of various filtrates from prior art presses

Table I.

Pulp mill filtrate	Extractives concentration, mg/l	Solids contents, mg/l
PGW hot loop	40-80	100 - 200
Disc filter		
cloudy filtrate	75-150	100 - 200
clear filtrate	50-120	50 - 150
super clear filtrate	40 - 100	<50
Filtrate from press	200 - 600	cf. Table II.

Table II.

Press	Extractives retention, %	Filtrate solids content, mg/l
Roll press	20-50	200-1000
Wire press	10-40	350-1000
Multi-press	*	1500 - 3000
Screw press	~ 0	2000 - 4000
* Extractives retention of the press in question is not known. Based on the operation of the apparatus it may be concluded that the retention is smaller than with a wire press.		

[0010] Based on both practical experience and performed studies, solids in the filtrate are known to deteriorate the operation of evaporation and filtration used as internal purification. It is a known fact that in evaporation the solids of the filtrate decrease the consistency of the concentrate. In membrane filtering the fibres are known to break the membrane.

[0011] In the present mechanical and chemi-mechanical pulp production, fibre recovery is usually not employed, or if it is, the fibre recovery is based on screening and filtering methods or flotation. Problems with these methods are for example: the low consistency of the recovered solids, the retention of lipophilic extractives into the solids to be recovered and/or the poor solids recovery degree. The problems in the separation are mostly due to the high fines content in the filtrate, the size of the lipophilic extractives is approx. 0.1 - 2 μm and the size of the fibre material $>5 \mu\text{m}$ which means that the filtering must employ a small hole size. Thus, the result achievable with the present fibre recovery methods is a compromise between the volume of the recovered fibres and the extractives load recycled to the process. Table III presents results obtained with various fibre recovery apparatus.

Table III.

Method	Solids recovery degree %	Extractives returned %	Discharge consistency %	Operation principle of separation method
Disc thickener	90-95	20-50	10-20	filtering through pulp cake
Flotation	85-98	30-55	1 - 15	20 - 80 μm air bubble
Micro screen	30-60	10-15	<1	screen plate with hole size 20-150 μm

EP 1 392 913 B1

(continued)

Method	Solids recovery degree %	Extractives returned %	Discharge consistency %	Operation principle of separation method
Certus microfilter	~100	93-99	*	ceramic filter with hole size 1 μm
Decanter centrifuge	>85	~0	25-30	settling based on centrifugal force
*discharge consistency not given				

[0012] The most common fibre recovering apparatus are disc and drum thickeners in which the fibre and the fines are filtered through a solids cake as completely as possible. This method gives a fairly high solids recovery degree but at the same time the solids cake filters efficiently also colloidal substances off from the water. If the thickness of the solids cake is decreased the retention of colloids decreases but also the solids recovery efficiency decreases.

[0013] In screening methods, for example Microscreen and curved screen, where the flow or a doctor wipes the screen surface preventing the formation of a solids cake, the retention of colloidal material into the fibre material to be recovered is smaller or there is no retention, but also the solids recovery is poor. Screening methods are mostly used to remove long fibres. Also the final consistency of the recovered solids remains low and therefore the recovered solids cannot be recycled to the high consistency pulp without adversely influencing its consistency. If the recovered solids must be recycled to the feed pulp of the press or the filtrate tank, the fines fraction of the solids starts to concentrate in the circulation and impair the operation of the press itself. If the speed of the flow or the movement of the doctor is slowed down, a solids cake begins to form, which increases the retention of colloidal material.

[0014] The flotation method gives a high degree of solids recovery. In a flotator air bubbles remove also colloidal material with the solids. A drawback of a flotator is the low consistency of the recovered material and the large share of the colloidal detrimental material returning to the process.

[0015] US-A- 5,468,396 discusses the treating of the process liquids of pulp and paper industry by means of a conventional centrifuge to remove from the liquids contaminants less dense than water, like resins. The document teaches how the filtrates of kraft pulping, for instance, are divided into three fractions in an ordinary centrifuge, the fractions being the light contaminants, purified liquid, and heavier contaminants, like fibers and fines. The specification teaches further that it would be advantageous to reduce the amount of fibers and fines in the liquid entering the centrifuge by means of a filter upstream of the centrifuge. And finally the specification teaches how the heavier contaminants are discharged from the apparatus intermittently via valves, which are opened for a short period. Thus, the apparatus of the US document is not purposed to continuous recovery of fibers from filtrates but rather to remove contaminants less dense than water from the, preferably, prefiltered filtrate.

[0016] The drawbacks of the prior art methods described above may be avoided by using in the solids recovery the centrifuge method and apparatus according to the invention according to which the solid material is removed mechanically. By selecting a suitable centrifugal force a situation is created where colloids containing lipophilic extractives do not settle but fibre and fibre-based solids do settle due to a higher density. In this way the solid material can be separated clean without lipophilic extractives attached to it.

[0017] According to a first aspect of the present invention, there is provided a method of continuously recovering both fibre and fibre-based solids from a filtrate, said filtrate of the mechanical or chemi-mechanical wood pulp processing industry containing both solids and colloidal lipophilic extractive material, the method comprising the steps of a. transporting said filtrate to a centrifuge developing a strong central acceleration, said centrifuge being either a decanter centrifuge or a screen bowl centrifuge; b. in said centrifuge separating the filtrate into two fractions, namely a liquid fraction containing the colloidal lipophilic extractives and a further fraction containing said fibre and fibre-based solids, the strong central acceleration generated in said centrifuge being such that, said further fraction containing said fibre and fibre-based solids settles onto an inner surface of said centrifuge; c. mechanically discharging said separated further fraction containing fibre and fibre-based solids from said centrifuge with the help of a screw conveyor arranged within said centrifuge; and d. removing the liquid fraction from said centrifuge as a separate flow.

[0018] According to a second aspect of the present invention, there is provided an apparatus for use in the mechanical and chemi-mechanical wood pulp processing industry, said apparatus comprising a device for separating a filtrate from mechanical or chemi-mechanical pulp, the filtrate containing both solids and colloidal lipophilic extractives, and a centrifuge for continuously recovering said fibre and fibre-based solids from the filtrate, wherein the centrifuge is either a decanter centrifuge or a screen bowl centrifuge, said centrifuge separating the filtrate into two fractions, namely a liquid fraction containing the colloidal lipophilic extractives and a further fraction containing said fibre and fibre-based solids, by generating a strong central acceleration in such a way that said further fraction containing said fibre and fibre-based

solids settles onto an inner surface of said centrifuge, and wherein said further fraction containing said fibre and fibre-based solids is mechanically discharged from said centrifuge with the help of a screw conveyor arranged within said centrifuge and said liquid fraction is removed from said centrifuge as a separate flow.

[0019] By using the method and apparatus of the invention, both a high consistency of the recovered solids and a high degree of recovery of fibres without the retention of lipophilic extractives are achieved. Thus there is no need to accept the aforementioned compromises. With the method and apparatus of the present invention, the consumption of water in paper mills can be more easily reduced than with prior art methods, and wood species having a higher content of extractives can be used in mechanical and chemi-mechanical pulp production.

[0020] Other characteristic features of the method and apparatus of the invention for recovering fibre-based solids and separating lipophilic extractives are disclosed in the dependent claims.

[0021] To enable a better understanding of the present invention, and to show how the same may be carried into effect, reference will now be made, by way of example only, to the accompanying drawings, in which:-

Fig. 1 illustrates a prior art process of manufacturing mechanical pulp ;

Figs. 2a and 2b illustrate schematically the operation principle of two different centrifuges;

Fig. 3 illustrates a so-called decanter centrifuge;

Fig. 4 illustrates a so-called screen bowl centrifuge;

Fig. 5 illustrates the results of a mill-scale test run of the method of the invention;

Fig. 6 illustrates a flow sheet used in the simulation of the method of the invention;

Fig. 7 illustrates the solids losses of the process obtained from the simulation according to Fig. 6 with different solids recovering methods, as a function of the volume of the filtrate taken to the solids recovery;

Fig. 8 illustrates the solids losses of the process obtained from the simulation according to Fig. 6 with various process filtrates, as a function of the volume of the filtrate discharged from the process;

Fig. 9 illustrates the separation efficiencies of lipophilic extractives obtained from the simulation according to Fig. 6 with various process filtrates, as a function of the volume of the filtrate discharged from the process;

Fig. 10 illustrates the separation efficiencies of lipophilic extractives obtained from the simulation according to Fig. 6 with various solids recovery methods, as a function of the volume of the filtrate taken to the solids recovery;

Fig. 11 illustrates the consistencies of the discharged pulp obtained from the simulation according to Fig. 6 with various solids recovery methods, as a function of the volume of the filtrate taken to the solids recovery;

Fig. 12 illustrates a preferred process application of the method and the apparatus of the invention;

Fig. 13 illustrates another preferred process application of the method and the apparatus of the invention;

Fig. 14 illustrates a third preferred process application of the method and the apparatus of the invention;

Fig. 15 illustrates a fourth preferred process application of the method and the apparatus of the invention;

Fig. 16 illustrates a fifth preferred process application of the method and the apparatus of the invention;

Fig. 17 illustrates a sixth preferred process application of the method and the apparatus of the invention;

Fig. 18 illustrates a seventh preferred process application of the method and the apparatus of the invention; and

Fig. 19 illustrates an eighth preferred process application of the method and the apparatus of the invention.

[0022] At first the separation method used in the method of the invention and the apparatus used in connection with it are described in more detail. Centrifuging means a sorting or a separation process based on the centrifugal force. The centrifugal force created in the centrifuging has the same kind of an effect on material as the gravitational force in settling. However, the centrifugal force created in the centrifuging is hundreds or thousands of times stronger than the gravitational force; therefore centrifuging

- gives a higher speed of settling of the particles,
- produces a denser layer of solids, and
- separates smaller particles than settling.

[0023] Centrifuges are divided into sedimentation and filtering centrifuges and into combinations of these. The sedimentation centrifuges mean apparatus in which the separation takes place by means of the centrifugal force, only (Fig. 2a). Apparatus of this kind are for example disc and decanter centrifuges, and tube and bottle centrifuges used in laboratories. Fig. 2a is a schematic illustration of a centrifuge which is composed of a cylinder 40 to be rotated at a high speed and having a closed wall. The centrifugal force separates from the material supplied into the cylinder 40 the heavy fraction against the wall of the cylinder to a dense layer 42 while the liquid and the lighter material remain as layers 44 of their own on top of the solid material layer.

[0024] Filtering centrifuges in turn are, in a way, combinations of filtering devices and centrifuges (Fig. 2b). In filtering centrifuges the separation of particles itself takes place by filtering. The starting point of the filtering centrifuges as well is a rotating cylinder 50, but unlike a sedimentation centrifuge, it has a porous surface provided with holes, slots or other

apertures suitable for the purpose. The driving force in the filtering is, however, the hydrostatic pressure created by the centrifugal force, which is why the methods are classified in separation methods based on centrifuging. Like in Fig. 2a, also in this embodiment the heavy material is accumulated onto the surface, in this case the perforated surface, of the cylinder and the lighter material closer to the axis of the cylinder. In this case, however, the liquid is removed via the apertures in the cylinder 50 and the extractives retain into the solid material layer. In the combinations of sedimentation and filtering centrifuges, particles are separated by means of the centrifugal force as in the sedimentation centrifuging. The combination apparatus additionally comprise a washing/thickening zone which functions according to the same principle as a filtering centrifuge.

[0025] Among other things the following properties are required from the centrifuge method used in the recovery of fibre and in the separation of fibre and extractives. The method must be continuous as the processes of the industry in this field are continuous and the liquid volumes to be treated are large. Batchtype operation is out of the question. The capacity must be high, at least ten litres per second. The method must be applicable in the treatment of sludges and suspensions. Also long-fibre suspensions are treated which further raises the requirements set on the apparatus. The fibre recovery degree must be high as the fibre is valuable paper manufacture raw material, which cannot be wasted. Naturally, significant extractives retention is not acceptable, either, as expressly a solution is sought by means of which the problems caused by extractives could be avoided in the manufacture of both pulp and paper. Further, the apparatus should be able to reach a high final consistency so as not to have to recycle the fibre returned from the apparatus for reuse back to the process via a thickener.

[0026] Experience with a filtering centrifuge indicates that filtering centrifuges have the same kind of problems as the present screening and filtering methods. In other words, compromises have to be made between the extractives retention and the degree of fibre recovery. Continuous sedimentation centrifuges, from which the solid material is removed through nozzles or slots (these devices are known by commercial names nozzle bowl, solid-ejecting bowl and nozzle-valve bowl centrifuges) do not work, either, in the fibre recovery or the separation of extractives because of the risk of clogging on the solids side. Naturally, the danger of clogging can be reduced by diluting the fibre fraction but this results in a much too low discharge consistency.

[0027] Based both on literature and practical experience the only possible apparatus for the applications in question would today be decanter centrifuges (Fig. 3) and the so-called screen bowl centrifuges (Fig. 4) (a combination apparatus). The advantage provided by the separation methods applied in these devices is that they are capable of separating solids of very different lengths (5-5000, μm) and using them, the solids can be removed at a high consistency.

[0028] The decanter centrifuge 60 illustrated in Fig. 3 and discussed for example in patent publication EP-A1-447742 comprises an outer casing 62, which surrounds the rotating parts of the device and comprises discharge outlets 64 and 66 for the thickened material and the filtrate. Inside the outer shell, there is a rotating bowl 68, one end 70 of which is in this structure conical and the other end 72 cylindrical. Each end of the bowl has been provided with discharge openings 74 and 76. These are located at the end 72 of the bowl 68 having a larger diameter in the end plate 78 of the bowl 68, and at the narrower end 70 directly along the periphery of the casing of the bowl 68. The bowl 68 has been supported with bearings 80 at both the ends. A screw conveyor 82 has been placed inside the bowl 68, the screw thread of which extends close to the inner wall of the bowl 68. The screw conveyor 82 and the bowl 68 have been connected to each other via gears 86 so that a small difference is created between the rotation speed of the screw conveyor 82 and that of the bowl 68. The purpose of this difference is to force the screw conveyor 82 to feed the solids separated by the centrifugal force onto the inner surface of the bowl 68 towards the outlet 74 at the narrower end 70 of the bowl 68. Further, in the embodiment of the figure, there is a pipe 88 extending from the narrower end 70 of the bowl 68 into the hollow inner space of the screw conveyor 82 and at the same time of the bowl 68; via this pipe the liquid to be treated is introduced into the screw conveyor 82. There is one or are several holes 92 in the casing 90 of the screw conveyor 82 approximately at the bending point between the conical portion 70 and the cylindrical portion 72 of the bowl 68, or a little towards the end on the conical portion side 70 from the bending point.

[0029] The decanter centrifuge illustrated in the figure works so that the suspension to be treated is supplied via the pipe 88 to the screw conveyor 82, which rotates at a high speed. From there the liquid shoots out due to the centrifugal force created by the high rotational speed via holes 92 into the bowl 68 and there, further due to the centrifugal force, the heavy solids are separated from the liquid onto the surface of the bowl 68 while the liquid, being lighter, remains further inside. The screw conveyor 82 rotating inside the bowl 68 scrapes with it solid material from the surface of the bowl 68 towards the narrower end 70 of the bowl and from there towards the outlet 74 while the liquid flows to the opposite direction, in other words to a direction where the liquid gets further away from the center line of the rotating bowl 68. The thickness of the liquid layer in the bowl 68 is determined by the liquid outlets 76, or rather their distance from the inner surface of the bowl 68. Thus, the liquid is discharged from the bowl via the opposite end compared with the solids. Of course, also other clearly lighter solid material, such as in the case of the invention the extractive material particles, are removed with the liquid. In this way the separated fractions are discharged from the apparatus each via their own outlets 64 and 66.

[0030] Decanter centrifuges have been disclosed also in Swedish patent publications 509400 and 501213. The basic

operation principles of the solutions disclosed in these are of course the same as that of the centrifuge illustrated in Fig. 3. Only for example the feed point of the liquid to be treated may vary which results in a little different flow directions of the fractions in the apparatus.

5 **[0031]** In a series of tests we performed it was found that the consistency of the solids accumulated on the surface of the centrifuge bowl 68 (i.e. in the layer between the liquid layer and the surface of the bowl) varied depending on the situation (among other things on the fibre-containing material and its volume) from a few percents even up to the level of about ten percent, sometimes even a little more than that. However, after the fibre layer had been scraped off by the screw conveyor 82 towards the narrower end of the bowl by "lifting" the solids layer from the liquid, the consistency rose in most cases to exceed twenty percent, in some cases even up to more than thirty percent.

10 **[0032]** The screen bowl centrifuge illustrated in Fig. 4 and disclosed in US patent no. 5,321,898 works in principle in the same way. In other words the division of the liquid into fractions is performed with a uniform, non-perforated rotating surface. The only more significant difference is that in the separation portion 96, into which in practise flows only solids separated from the liquid, there is a screen surface 97 through which the finer fraction of the solids is removed from the apparatus to a discharge hopper 98. The coarser fraction of the solids is discharged via the end of the apparatus to a discharge chute 99. This portion may also be called a solids washing portion.

15 **[0033]** Thus, the solving of the problems the invention addresses can be started with an apparatus, the characteristic features of which are both that the liquid is divided into fractions by a revolving unbroken surface, and that the revolving speed of the apparatus, more precisely that of the bowl or the cylinder of the apparatus, is high. As in fact a more important factor than the revolving speed is the central acceleration the apparatus develops, we have determined it in our experiments. Based on the tests we have performed, the central acceleration should be more than 200 * g, preferably more than 700 * g, most preferably more than 1000 * g.

20 **[0034]** In the following, a mill-scale test run is described, in which the function of a decanter centrifuge was tested in the separation of extractive material. A test run was performed with a solids recovery method and a method for separating solids and extractives in a productions scale PGW pulp production plant in connection with a paper mill. The wood species were spruce and the filtrate was filtrate from a washing press. The bleaching process was ditionite bleaching and the pulp was brought to the washing press directly from a disc filter. A bleaching press was not in use. The solids recovery apparatus was a decanter centrifuge; the capacity of the decanter centrifuge was informed by the producer of the apparatus to be 20 m³/h. The length of the centrifuge was 3975 mm, the width 1140 mm and the height 1570 mm. Figure 5 illustrates the different degrees of solids recovery at different feed rates as a function of the rotating speed of the decanted cylinder.

25 **[0035]** From the test results it is worth mentioning that, as is clear also in theory, the separation efficiency of the centrifuge increased when the number of revolutions was raised. An increase in the revolution speed from 2260 rpm to 2640 rpm at a capacity of 20 m³/h raised the recovery degree from 82 % to 88 %. It should also be noted that at the maximum capacity the recovery degree at 2640 rpm was still of the order of 82 %.

30 **[0036]** The test apparatus was adjusted to give as high a discharge consistency of the solids as possible. This kind of an adjustment is as such better suited in the concentration of the biological sludge of waste water treatment plants than in the treatment of pulp production waters. By optimising the apparatus the solids recovery degree and the capacity can be improved further.

35 **[0037]** The application of the method of the invention in a conventional mechanical pulp production process is described in the following (Fig. 6). In the figure, the reference number 100 refers to the wood material brought to the process, the material being diluted to a suitable consistency at 102. Filtrate from the circulation water tank 104 of the process is used in the dilution. The pulp obtained from the dilution is brought to screening 106 and the accepted fraction obtained from the screening is thickened for example with a disc filter 108. The purpose of the thickening is both, as is natural, to raise the consistency of the pulp and to remove extractives from the pulp. The thickened pulp is reintroduced to dilution 110 where the consistency is adjusted to be suitable for further processing. Subsequently, the pulp is brought to a washer 112, which is preferably a press, either a screw or a wire press. After the wash the pulp 114 is transported either directly to the paper mill or to bleaching.

40 **[0038]** Figure 6 illustrates also, how the filtrate from the thickener 108, which in this example is disc filter, and the wash filtrate from the washer 112, however, via a filtrate tank 116 of its own, are brought to a circulation water tank 104, where filtrates from different sources are mixed with each other.

45 **[0039]** Up to this point only a prior art method of mechanical pulp production has been described. Now, in order to test the method of the invention, a decanter centrifuge 60 has been connected to the process and filtrate obtained from the washer 112 is brought from the filtrate tank 116 to the decanter centrifuge via a valve 118. The task of the centrifuge 60 is to recover from the filtrate fibre material suitable for paper production, the material being guided in a flow 120 to pulp 114, which is forwarded to further processing, and to separate from the filtrate lipophilic extractives to a separate flow 122.

50 **[0040]** Figure 6 further illustrates with the reference number 124 clean fresh water brought to the process to replace the water volume discharged from the process. Water is removed for example with the pulp 114 discharged from the

EP 1 392 913 B1

process and both from the circulation water tank 104 in the flow 126 and from the filtrate tank 116 with the extractives in the flow 122.

[0041] In the study of the process described above, a simulation model was used with which results were obtained which correspond very well to the reality. The simulation was carried out with the version 2.4.08 of the Balas simulation program. The flow sheet presented in Figure 6 has been drawn with the version 4.45 of the FloSheet program delivered with the Balas simulation program. In the simulation model the arrows indicate the direction of the flow in question. The following mathematical methods and parameters have been used in the simulation model:

- The simulation takes place in a balanced situation when the operation of the process is stable.
- In the simulation, a 'softwood' component is treated as the solid material, lipophilic extractive material both in a water phase and in a solids phase as the 'org' component, and water as the 'water' component.
- The consistency has been determined by dividing the 'softwood' flow by the total flow, in other words the lipophilic extractives have not been calculated as solids.
- Lipophilic extractives only in the water phase can be separated with the water in a press/thickener, the lipophilic extractives in the solid phase move with the solid material. Thus, the retention of the lipophilic extractives relates to the behaviour of lipophilic extractives in the water phase, only.
- The retained lipophilic extractives remain in the water phase.

[0042] The flows and apparatus of the simulation model:

100 Wood into the process. The solids flow is chosen to be 1 kg/s. The total volume of lipophilic extractives is known to be 8 mg/g and their share in the water phase is 60 %. The water flow is 0.992 kg/s. Thus, the consistency is 50 % and the total flow rate 2 kg/s.

102 Dilution to a consistency of 0.65 % for screening 106 (not used in the simulation). The dilution is performed with filtrate from the circulation water tank 7. The module used is CONSYS.

108 Thickening, the typical values of the disc filter are used in the simulation. The final consistency 13 %, the retention of lipophilic extractives 30 %, the solids recovery degree 99 %, the calculation module used FLOTA2. Because of its simplicity, this thickener, which corresponds to a disc, produces only one filtrate. The solids content of the filtrate is 68.4 mg/l.

110 Dilution with the filtrate from the circulation water tank 44 to a consistency of 6 %. The module used CONSYS.

112 A press serving as a washer. In the simulation, typical readings of both a wire press and a screw press have been used for comparison.

- the values of a wire press: final consistency 40 %, retention of lipophilic extractives 30 %, recovery degree of solids 99 %, the module used FLOTA2. The solids content of the filtrate of this press is 704,6 mg/l.

- the values of a screw press: final consistency 40 %, retention of lipophilic extractives 0 %, recovery degree of solids 97 %, the module used FLOTA2. The solids content of the filtrate of this press is 2106,5 mg/l.

114 The pulp discharged from the process directly to the paper mill or to bleaching. Also the solids 120 obtained from the solids recovery is introduced into this pulp.

104 A circulation water tank where the incoming waters are completely mixed with each other. The module used MIXDIV.

116 The filtrate tank of the press. The module used MIXDIV.

(continued)

60 Recovery of solids. The decanter centrifuge parameters measured earlier or otherwise known, and typical
 5 parameters of a disc filter and a screening method were used. In some simulations, solids were not recovered,
 in these cases the filtrate was guided unchanged past the solids recovery to the discharging filtrate 122 of the
 press 112. - The values of the decanter centrifuge: final consistency 27 %, retention of lipophilic extractives
 0 %, recovery degree of solids 90 %, the module used FLOTA2. - The values of the screening method: final
 10 consistency 1%, retention of lipophilic extractives 0 %, recovery degree of solids 60 %, the module used
 FLOTA2. - The values of the disc filter: final consistency 15 %, retention of lipophilic extractives 30 %, recovery
 degree of solids 95 %, the module used FLOTA2.

124 Fresh water to be fed into the process, which replaces the water discharged. Water is discharged for the
 process with the discharged pulp 114 and in the circulation water discharge 126 and filtrate discharged, 122,
 15 of the press 116 if they are used. This replacing fresh water is perfectly clean water.

122 Water fraction from the solids recovery, which is discharged from the process.

126 Water fraction from the circulation water tank 104, which is discharged from the process.

20 118 Valve for regulating the solids flow to the solids recovery. The module used FSET.

128 Valve for regulating the water fraction 126 discharged from the process from the circulation water tank 104.
 The module used FSET.

25 **[0043]** Figure 7 illustrates the solids losses (%) of the process obtained from a simulation according to Figure 6 as a
 function of the filtrate volume flowing to the solids recovery (l/kg abs. dry matter) with different solids recovery methods.
 The recovery methods were a decanter centrifuge, a screening method and a disc filter. For comparison, also a case
 30 was taken up where solids were not recovered. The results indicate that the solids losses with a decanter centrifuge
 and a disc filter are essentially the same, i. e. less than 10 % compared with a situation where solids were not recovered.
 In the screening method on the other hand, the solids losses were a little more than one third compared with the situation
 with no fibre recovery.

[0044] Figure 8 illustrates solids losses (%) of the process obtained from a simulation according to Figure 6 as a
 function of the filtrate volume (l/kg abs. dry pulp) discharged from the process with different process filtrates. The process
 35 filtrates treated were filtrates from a screw press and a wire press and for comparison so-called clear filtrate of the
 present technology. The amount of solids removed with the filtrate from a screw press is about three times the amount
 removed by a wire press, and roughly expressed about twenty times the amount removed with a clear filtrate.

[0045] Figure 9 illustrates separation efficiencies of lipophilic extractives (%) as a function of the filtrate volume dis-
 40 charged from the process (l/kg abs. dry pulp) obtained from a simulation according to Figure 6 with different process
 filtrates. In the separation of lipophilic extractives a screw press reaches a level of its own. Its separation efficiency very
 quickly rises over thirty percent and ends up at over fifty percent. The separation efficiency of a wire press rises more
 slowly, however, reaching in the end a level of close to forty percent.

[0046] Figure 10 illustrates separation efficiencies of lipophilic extractives (%) as a function of the filtrate volume flowing
 45 to the solids recovery (l/kg abs. dry pulp) obtained from a simulation according to Figure 6 with different solids recovery
 methods. The recovery methods were the same as in Figure 6. The best separation efficiency was reached with a
 decanter centrifuge or, when solids were not recovered, the screening method was a little worse and the disc filter even
 a little worse than the screening method.

[0047] Figure 11 illustrates consistencies (%) of the discharged pulp as a function of the filtrate volume flowing to the
 fibre recovery (l/kg abs. dry pulp) obtained from a simulation according to Figure 6 with different solids recovery methods.
 50 An interesting feature is that the consistency of the discharging pulp remains practically constant irrespective of the
 volume of filtrate with all other recovery methods except with the screening method with which the consistency decreased
 from forty percent to less than 25 percent.

[0048] Thinking more broadly, the results clearly indicate that removing filtrate from the circulation water tank gives a
 remarkably weaker separation efficiency than separating filtrate from a wire press serving as the press. The separation
 55 efficiency can still be improved by replacing the wire press with a screw press, which does not retain lipophilic extractives.
 Improving the separation efficiency also strongly increases fibre losses. Solids losses of this magnitude are not accept-
 able.

[0049] The use of a decanter centrifuge does not impair the separation efficiency whereas other recovery methods

do (Fig. 10). The use of a screening method brings about the additional problems of great solids losses (Fig. 7) and a decrease in the consistency of the discharged pulp (Fig. 11). The decrease in the consistency of the discharged pulp prevents the recycling of the recovered solids to the high-consistency pulp of the press at a point of the process where high consistency is important (for example the operation of a high consistency bleaching).

5 **[0050]** The results indicate that by using a decanter centrifuge in the recovery of solids and an efficient press (for example a screw press) the water consumption of the process can be reduced remarkably from the present situation. Despite the reduction of water consumption to one fifth, the separation efficiency of lipophilic extractives is almost doubled.

10 **[0051]** A process application according to a preferred embodiment of the invention is illustrated in Figure 12. The application is a PGW plant (also GW and other processes based on grinding), into which the wood material 140 is brought in the form of logs, which are ground under high pressure. The fibre suspension produced as a result of the grinding 142 is transported to a so-called hot loop thickening 144 where filtrate is removed from the suspension. The suspension itself continues thickened to a sorting 146 and the filtrate to a hot water tank 148. A part of the liquid from the hot water tank 148 is returned to the grinding 142 and a part is taken to a decanter centrifuge 60 where the solids S are recovered from the liquid in the manner described above and can be recycled to the process. The extractives E remaining in the liquid phase are discharged from the process separate from the solids S.

15 **[0052]** Figure 13 illustrates a process application according to another preferred embodiment of the invention. Also this application relates to a PGW plant (also GW and other processes based on grinding) and resembles closely the application in Figure 12; in the version of Figure 13, only a press 150 has been added after the hot loop thickener 144. In this embodiment the filtrate from the press 150 is taken to a filtrate tank 152 from which at least a portion of the filtrate is further taken to decanter centrifuge 60 where the extractive material and the solids to be recovered and to be recycled to the process are separated to form separate flows.

20 **[0053]** The process applications illustrated in the following Figures 14 - 16 are applicable in any mechanical or chemi-mechanical pulp production process. Figure 14 illustrates a process application according to a third preferred embodiment of the invention. This application relates to a pulp manufacturing process portion following a sorting 160. After the sorting 160 the pulp suspension is guided to a thickening 162 where the filtrate is separated and transported to a circulation water tank 164. A portion of the filtrate is returned to the pulp suspension prior to the sorting 160 to dilute the suspension and a portion is guided to the decanter centrifuge 60 where the usable solid material S is separated from the filtrate for recycling to the process, and the extractive material E for removal from the process.

25 **[0054]** Figure 15 illustrates a process application according to a fourth preferred embodiment of the invention. This application relates to a thickening and pressing process preceding the bleaching of mechanical or chemi-mechanical pulp. Before the bleaching itself the pulp is fed into a thickening 170, in which filtrate is removed to a circulation water tank 172 in order to raise the consistency. The thickened fibre suspension is introduced further to a bleaching press 174, where filtrate is further removed from the suspension. The fibre suspension travels from the bleaching press 174 to bleaching 176 and the filtrate from the press 174 to a filtrate tank 178. A portion of the filtrate collected to the filtrate tank 178 is transported to dilute the pulp before the thickening 170 and a portion to the decanter centrifuge 60, where the filtrate is divided in the way described above into a fraction containing solids S to be recycled into the process, and into a fraction containing extractives E to be removed from the process.

30 **[0055]** Figure 16 illustrates a process application according to a fifth preferred embodiment of the invention suitable for use in connection with any of the processes covered by this invention. In this application the decanter centrifuge has been arranged to treat filtrate from a washing press 182 following a bleaching 180. In the figure, a portion of the filtrate of the washing press 182 is guided from the filtrate tank 184 back to the process to be used prior to the press 182 in the dilution of the fibre suspension while a portion flows to the decanter centrifuge 60. In the decanter centrifuge 60, the solid material S is separated from the filtrate for recycling to the process and the extractives E for removal from the process.

35 **[0056]** Figure 17 illustrates a process application according to a sixth preferred embodiment of the invention. It describes a refining process (CTMP or APMP); the fibre suspension obtained after a refining phase 190 of the process is transported to a press 192 in which filtrate is pressed out from the suspension by a known method. The filtrate is guided to a filtrate tank 194 from which at least a portion of the filtrate is guided to a decanter centrifuge 60, which separates from the filtrate the recoverable solids S to a flow of its own to be returned to the process and the extractive material E to a flow to be discharged from the process.

40 **[0057]** Figure 18 illustrates a process application according to a seventh preferred embodiment of the invention. Also that describes for example a refining process (TMP, CTMP, CMP, APMP and other processes in which the wood raw material is chopped into chips prior to at least a partial mechanical defiberizing), in which a first press 200 is arranged to treat the chips. It has been found advantageous to recover already at this stage at least part of the filtrate via a filtrate tank 202 to the decanter centrifuge 60 in order to separate from each other the extractives E, and the solids S to be returned to the process.

45 **[0058]** Figure 19 illustrates a process application according to an eighth preferred embodiment of the invention, suitable for use in connection with any mechanical or chemi-mechanical process. The figure illustrates how an apparatus 212

has been disposed after a filtrate tank 210 and prior to a decanter centrifuge 60; the apparatus 212 can be for example a screen, a separator, a fractionator, a thickener or a corresponding device, which is intended to have an appropriate influence on the filtrate to be introduced into the decanter centrifuge 60. One possibility is for example a thickener with which water is separated from the filtrate flowing to the decanter centrifuge whereby the size of the centrifuge required can be reduced as the liquid flow to be treated decreases. In addition to the rise in the consistency, the process described also creates a situation where, when the apparatus 212 is for example a disc filter (the consistency of the incoming pulp for example 0.3%) whereby the extractives readily remain in the suspension thickened by the disc filter, there are in the filtrate of the disc filter (consistency 0 %) relatively small amounts of extractives as they accumulate into the cake (consistency 0,6 %) of the disc filter which is transported further to the centrifuge. Then, although the centrifuge can be fairly small in size the liquid flow it treats contains remarkable amounts of extractives. Another alternative is an apparatus separating fibre fractions with which a portion of the fibre can be removed before the centrifuge.

[0059] It should also be noted that, as was already stated in connection with the prior art, the dilution and the subsequent thickening/pressing in fact corresponds to a washing of the pulp. Thus, it is clear that as far as this invention is concerned the processed described above can include also washers, which in this context are devices in which the consistency of the pulp fed into the device and that of the pulp discharged from the devices are essentially the same. Thus, it is also clear that the filtrate of the washer is analogous with the filtrate of a thickener or a press or a corresponding device, which removes liquid from the pulp, and thus it can be treated in a decanter centrifuge or a corresponding device for separating extractives from the usable solids.

[0060] It should be noted from the above description, that although the whole description speaks about a decanter centrifuge the method may employ a screen bowl centrifuge as described above.

[0061] Further, it should be understood that although in the example above the decanter centrifuge or the corresponding device 60 is always preceded by a filtrate tank, in suitable conditions this can be omitted altogether, in which case there is a pipeline extending from a press or a corresponding device to the decanted centrifuge or a corresponding device. In the same way, the filtrate tank can be replaced by two or even three filtrate tanks if the preceding liquid removing devices allows separating several types of filtrates (for example cloudy, clear, super clear). Thus it is further clear that each portion of the above filtrates can be used in the way desired (for example as dilution liquid, as liquid to be treated in a decanter centrifuge, as waste water to be transferred to a channel, etc.)

[0062] As can be understood from the above description, a new type of a method has been developed for treating the filtrates of the mechanical and chemimechanical wood processing industry and in particular for removing lipophilic extractives from the filtrates in question. It should be kept in mind that the several examples of the invention described above are only illustrative examples of the many variations of the invention that is defined in the appended claims.

Claims

1. A method of continuously recovering both fibre and fibre-based solids from a filtrate of the mechanical or chemi-mechanical pulp wood processing industry, said filtrate containing both solids and colloidal lipophilic extractive material, the method comprising the steps of
 - a. transporting said filtrate to a centrifuge (60) developing a strong central acceleration, said centrifuge (60) being either a decanter centrifuge or a screen bowl centrifuge;
 - b. in said centrifuge (60) separating the filtrate into two fractions, namely a liquid fraction (E) containing the colloidal lipophilic extractives and as further fraction (S) containing said fibre and fibre-based solids, the strong central acceleration generated in said centrifuge (60) being such that said further fraction containing said fibre and fibre-based solids settles onto an inner surface of said centrifuge (60) ;
 - c. mechanically discharging said separated further fraction (s) containing fibre and fibre-based solids from said centrifuge (60) with the help of a screw conveyor (82) arranged within said centrifuge (60); and
 - d. removing the liquid fraction (E) from said centrifuge (60) as a separate flow.
2. A method according to claim 1, wherein said filtrate is the filtrates of a washer (112), a press or a thickener.
3. A method according to claim 1, wherein said further fraction (S) containing the fibre and the fibre-based solids is discharged from said centrifuge (60) at a consistency of more than 20 percent so that it can be recycled straight to the main pulp flow of either a paper mill or a bleaching process.
4. A method according to claim 3, wherein said filtrate is:
 - the filtrate from a hot loop thickening step (144) of a pulp producing plant, or

- the filtrate from a press (150) following a hot loop thickening step (144) of a pulp producing plant, or
 - the filtrate from a thickening step (162) following a sorting step (160) in a pulp producing plant, or
 - the filtrate from a bleaching press (174) preceding a bleaching step (176) in a pulp producing plant, or
 - the filtrate from a washing press (182) following a bleaching step (180) in a pulp producing plant, or
 - the filtrate from a press (192) following a refining step (190) in a pulp producing plant, or
 - the filtrate from a chip press (200) in a pulp producing plant.
- 5
5. A method according to claim 1, wherein prior to step a), said filtrate is treated at least in one of a fractionator, a thickener, a screen or a separator.
- 10
6. A method according to claim 1, wherein the central acceleration is greater than 200*g.
7. An apparatus for use in the mechanical and chemi-mechanical wood pulp processing industry, said apparatus comprising a device (112, 144, 150, 162, 174, 182, 192, 200) for separating a filtrate from mechanical or chemi-mechanical pulp, the filtrate containing both solids and colloidal lipophilic extractives, and a centrifuge (60) for continuously recovering said fibre and fibre-based solids from the filtrate, wherein the centrifuge (60) is either a decanter centrifuge or a screen, bowl centrifuge, said centrifuge (60) separating the filtrate into two fractions, namely a liquid fraction (E) containing the colloidal lipophilic extractives and a further fraction (S) containing said fibre and fibre-based solids, by generating a strong central acceleration in such a way that said further fraction (S) containing said fibre and fibre-based solids settles onto an inner surface of said centrifuge (60), and wherein said further fraction (S) containing said fibre and fibre-based solids is mechanically discharged from said centrifuge (60) with the help of a screw conveyor (82) arranged within said centrifuge (60) and said liquid fraction (E) is removed from said centrifuge (60) as a separate flow.
- 15
- 20
8. An apparatus according to claim 7, wherein a device, (212) for pre-treating the filtrate is provided between said filtrate separating device and said centrifuges
- 25
9. An apparatus according to claim 8, wherein the pre-treating device (212) is a screen, a thickener, a fractionator and/or a separator.
- 30
10. An apparatus according to claim 7, wherein said inner surface of said centrifuge (60) on which said further material fraction (S) containing said fibre and fibre-based solids settles during separation is unbroken.
- 35
11. An apparatus according to claim 10, wherein the filtrate separating device (112, 144, 150, 162, 174, 182, 192, 200) is a thickener, a press or a washer.

Patentansprüche

- 40
1. Verfahren zum kontinuierlichen Rückgewinnen von sowohl Faser-, als auch faserbasierten Feststoffen aus einem Filtrat einer mechanischen oder chemomechanischen Zellstoff verarbeitenden Industrie, wobei die Feststoffe sowohl festes, als auch kolloidales lipophiles extrahiertes Material enthalten, das Verfahren umfasst die Schritte
- 45
- a) Transportieren des Filtrats zu einer Zentrifuge (60), die eine starke Zentralbeschleunigung entwickelt, wobei die Zentrifuge (60) entweder eine Dekanterzentrifuge oder eine Filterkugelnzentrifuge ist;
 - b) wobei in der Zentrifuge (60) das Filtrat in zwei Anteile getrennt wird, nämlich in einen flüssigen Anteil (E), der das kolloidale, lipophile extrahierte Material enthält und einen weiteren Anteil (S), der die Faser- und faserbasierten Feststoffe enthält, wobei die starke Zentralbeschleunigung, die in der Zentrifuge (60) erzeugt wird, derart gestaltet ist, dass der weitere Anteil, der die Faser- und faserbasierten Feststoffe enthält, sich an einer inneren Oberfläche der Zentrifuge (60) absetzt;
 - c) mechanisches Entladen des getrennten weiteren Anteils (S), der die Faser- und faserbasierten Feststoffe enthält, aus der Zentrifuge (60) mit der Hilfe eines Schraubenförderers (82), der innerhalb der Zentrifuge (60) angeordnet ist; und
 - d) Entfernen des flüssigen Anteils (E) aus der Zentrifuge (60), als getrennten Fluss.
- 50
- 55
2. Verfahren nach Anspruch 1, bei dem das Filtrat ein Filtrat eines Waschapparats (112), einer Presse oder eines Eindickers ist.

EP 1 392 913 B1

3. Verfahren nach Anspruch 1, bei dem der weitere Anteil (S), der die Faser- und faserbasierten Feststoffe enthält, aus der Zentrifuge (60) in einer Stoffdichte von mehr als 20 Prozent abgeführt wird, so dass er direkt in dem Hauptfluss entweder einer Papierfabrik oder eines Bleichverfahrens wiederverwertet werden kann.
- 5 4. Verfahren nach Anspruch 3, bei dem das Filtrat ist:
- das Filtrat aus einem Heisssschlaufeneindickungsschritt (144) einer feststoff erzeugenden Anlage, oder
 - das Filtrat aus einer Presse, (150) die einem einem Heisssschlaufeneindickungsschritt (144) einer feststoff erzeugenden Anlage folgt, oder
 - 10 - das Filtrat aus einem Eindickungsschritt (162), der einem Sortierschritt (160) in einer feststoff erzeugenden Anlage folgt, oder
 - das Filtrat aus einer Bleichpresse (174) die in einer feststoff erzeugenden Anlage einen Bleichschritt (176) voranstellt, oder
 - das Filtrat aus einer Waschpresse (182) die einem Bleichschritt (180) in einer feststoff erzeugenden Anlage
 - 15 folgt, oder
 - das Filtrat aus einer Presse (192), die einem Verfeinerungsschritt (190) in einer feststoff erzeugenden Anlage folgt, oder
 - das Filtrat aus einer Chip-Presse in einer feststoff erzeugenden Anlage.
- 20 5. Verfahren nach Anspruch 1, bei dem vor Schritt a) das Filtrat zumindest in einem Zerkleinerer, einem Eindicker, einem Filter oder einem Trenner behandelt wird.
6. Verfahren nach Anspruch 1, bei dem die Zentralbeschleunigung größer als 200g ist.
- 25 7. Vorrichtung für die Verwendung in einer mechanischen und chemomechanischen Zellstoff verarbeitenden Industrie, wobei die Vorrichtung eine Einrichtung (112, 144, 150, 162, 174, 182, 192, 200) zum Trennen eines Filtrats von einem mechanischen oder chemomechanischen Stoff umfasst, wobei das Filtrat sowohl festes, als auch kolloidales lipophiles extrahiertes Material enthält, und eine Zentrifuge (60) zum kontinuierlichen Rückgewinnen der Faser-, als auch faserbasierten Feststoffe aus dem Filtrat umfasst, bei der die Zentrifuge (60) entweder eine Dekanterzentrifuge oder eine Filterkugelnzentrifuge ist, wobei die Zentrifuge (60) das Filtrat in zwei Anteile trennt, nämlich einen
- 30 flüssigen Anteil (E), der das kolloidale, lipophile extrahierte Material enthält und einen weiteren Anteil (S), der die Faser- und faserbasierten Feststoffe enthält, durch Erzeugen einer starken Zentralbeschleunigung in einer solchen Weise, dass der weitere Anteil, (S) der die Faser- und faserbasierten Feststoffe enthält, sich an einer inneren Oberfläche der Zentrifuge (60) absetzt, und bei der der weitere Anteil (S), der die Faser- und faserbasierten Feststoffe
- 35 enthält, mechanisch von der Zentrifuge (60) abgeführt wird, mit Hilfe eines Schraubenförderers (82), der innerhalb der Zentrifuge (60) angeordnet ist, und der flüssige Anteil (E) von der Zentrifuge als getrennter Fluss entfernt wird.
8. Vorrichtung nach Anspruch 7, bei der eine Einrichtung (212) für das Vorbehandeln des Filtrats zwischen der Filtrattrenneinrichtung und der Zentrifuge angeordnet ist.
- 40 9. Vorrichtung nach Anspruch 8, bei der die vorbehandelnde Einrichtung (212) ein Filter, ein Eindicker, ein Zerkleinerer und/oder ein Trenner ist.
10. Vorrichtung nach Anspruch 7, bei der die innere Oberfläche der Zentrifuge (60), auf der sich der weitere, die Faser- und faserbasierten Feststoffe enthaltende Anteil (S) während der Trennung absetzt, ungebrochen ist.
- 45 11. Vorrichtung nach Anspruch 10, bei der die Filtrattrenneinrichtung (112, 144, 150, 162, 174, 182, 192, 200) ein Eindicker, eine Presse oder ein Waschapparat ist.

50

Revendications

1. Procédé destiné à récupérer en continu à la fois des fibres et des solides à base de fibres à partir d'un filtrat de l'industrie de traitement de la pâte de bois mécanique ou chimio-mécanique, ledit filtrat contenant à la fois des solides et du matériau d'extraction lipophile colloïdal, le procédé comprenant les étapes consistant à :
- 55 a. transporter ledit filtrat à une centrifugeuse (60) développant une forte accélération centrale, ladite centrifugeuse (60) étant soit une centrifugeuse à décantation soit une centrifugeuse à bol percé,

EP 1 392 913 B1

- b. dans ladite centrifugeuse (60) séparer le filtrat en deux fractions, à savoir une fraction liquide (E) contenant les extraits lipophiles colloïdaux et une autre fraction (S) contenant lesdites fibres et lesdits solides à base de fibre, la forte accélération centrale générée dans ladite centrifugeuse (60) étant telle que ladite autre fraction contenant lesdites fibres et lesdits solides à base de fibre se dépose sur une surface interne de ladite centrifugeuse (60),
- c. décharger mécaniquement ladite autre fraction séparée (S) contenant lesdites fibres et lesdits solides à base de fibre à partir de ladite centrifugeuse (60) à l'aide d'un transporteur à vis sans fin (82) agencé dans ladite centrifugeuse (60), et
- d. retirer la fraction liquide (E) de ladite centrifugeuse (60) en tant que flux séparé.
2. Procédé selon la revendication 1, dans lequel ledit filtrat est le filtrat d'une pile laveuse (112), d'une presse ou d'un épaisseur.
3. Procédé selon la revendication 1, dans lequel ladite autre fraction (S) contenant les fibres et les solides à base de fibre est déchargée à partir de ladite centrifugeuse (60) à une concentration de plus de 20 pourcents de manière à ce qu'elle puisse être recyclée directement au flux de pâte principal soit d'un broyeur de papier soit d'un procédé de blanchiment.
4. Procédé selon la revendication 3, dans lequel ledit filtrat est :
- le filtrat d'une étape d'épaississement en boucle active (144) d'une installation de production de pâte, ou
 - le filtrat d'une presse (150) suivant une étape d'épaississement en boucle active (144) d'une installation de production de pâte, ou
 - le filtrat d'une étape d'épaississement (162) suivant une étape de triage (160) dans une installation de production de pâte, ou
 - le filtrat d'une presse de blanchiment (174) précédant une étape de blanchiment (176) dans une installation de production de pâte, ou
 - le filtrat d'une presse de lavement (182) suivant une étape de blanchiment (180) dans une installation de production de pâte, ou
 - le filtrat d'une presse (192) suivant une étape de raffinage (190) dans une installation de production de pâte, ou
 - le filtrat presse à copeaux (200) dans une installation de production de pâte.
5. Procédé selon la revendication 1, dans lequel avant l'étape a), ledit filtrat est traité au moins dans l'un d'un fractionneur, d'un épaisseur, d'un tamis ou d'un séparateur.
6. Procédé selon la revendication 1, dans lequel l'accélération centrale est supérieure à 200*g.
7. Appareil pour une utilisation dans l'industrie de traitement de la pâte de bois mécanique ou chimiomécanique, ledit appareil comprenant un dispositif (112, 144, 150, 162, 174, 182, 192, 200) pour séparer un filtrat de la pâte mécanique ou chimiomécanique, le filtrat contenant à la fois des solides et des extraits lipophiles colloïdaux, et une centrifugeuse (60) pour récupérer en continu lesdites fibres et lesdits solides à base de fibre à partir du filtrat, dans lequel la centrifugeuse (60) est soit une centrifugeuse à décantation soit une centrifugeuse à bol percé, ladite centrifugeuse (60) séparant le filtrat en deux fractions, à savoir une fraction liquide (E) contenant les extraits lipophiles colloïdaux et une autre fraction (S) contenant lesdites fibres et lesdits solides à base de fibre, en générant une forte accélération centrale de telle sorte que ladite autre fraction (S) contenant lesdites fibres et lesdits solides à base de fibre se dépose sur une surface interne de ladite centrifugeuse (60), et dans lequel ladite autre fraction (S) contenant lesdites fibres et lesdits solides à base de fibre est mécaniquement déchargée à partir de ladite centrifugeuse (60) à l'aide d'un transporteur à vis sans fin (82) agencé dans ladite centrifugeuse (60) et ladite fraction liquide (E) est retirée de ladite centrifugeuse (60) en tant que flux séparé.
8. Appareil selon la revendication 7, dans lequel un dispositif (212) pour prétraiter le filtrat est prévu entre ledit dispositif de séparation de filtrat et ladite centrifugeuse.
9. Appareil selon la revendication 8, dans lequel le dispositif de prétraitement (212) est un tamis, un épaisseur, un fractionneur et/ou un séparateur.
10. Appareil selon la revendication 7, dans lequel ladite surface interne de ladite centrifugeuse (60) sur laquelle ladite autre fraction de matériau (S) contenant lesdites fibres et lesdits solides à base de fibre se dépose pendant la

séparation est intact.

11. Appareil selon la revendication 10, dans lequel le dispositif de séparation de filtrat (112, 144, 150, 162, 174, 182, 192, 200) est un épaisseur, une presse ou une pile laveuse.

5

10

15

20

25

30

35

40

45

50

55

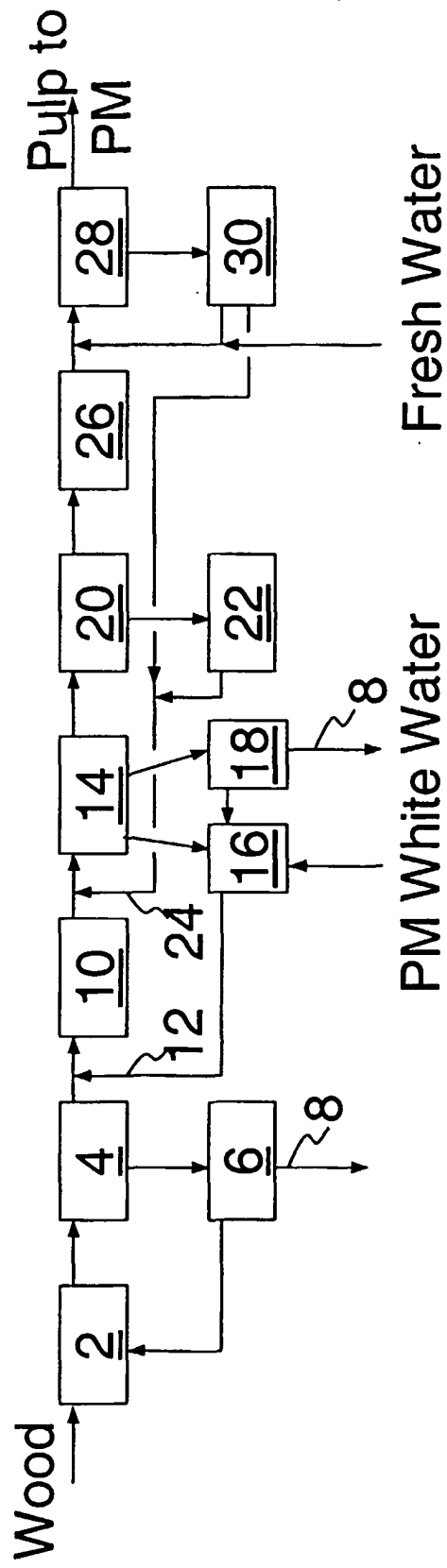

Fig. 1

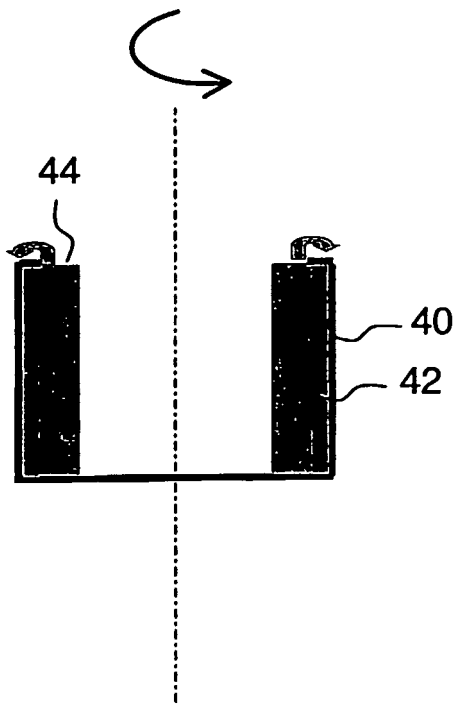

Fig. 2a

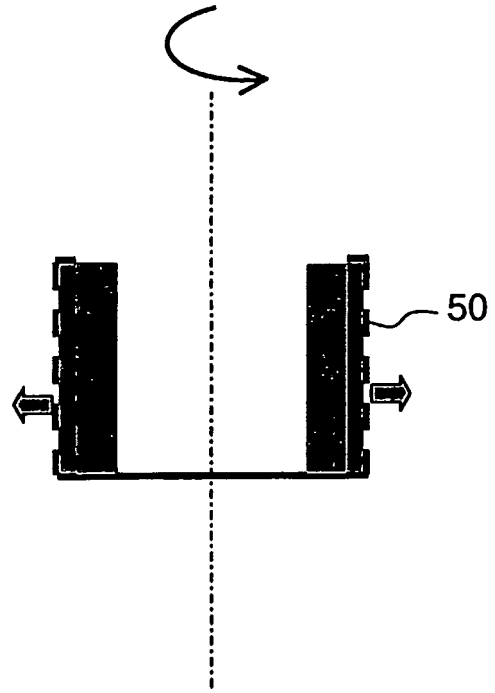

Fig. 2b

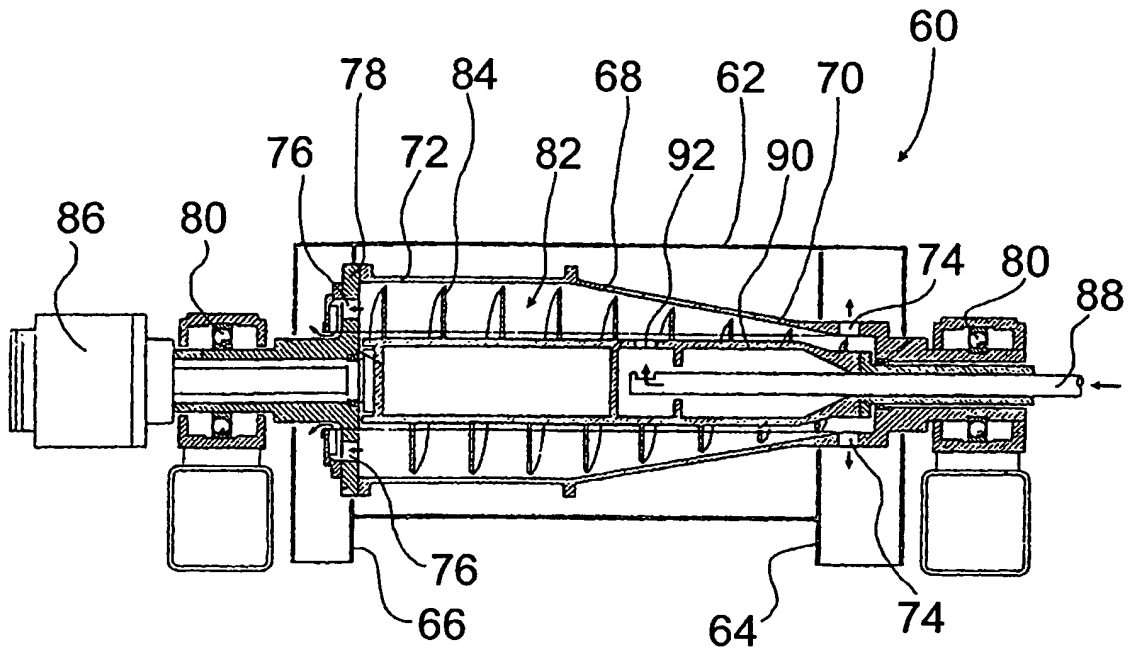

Fig. 3

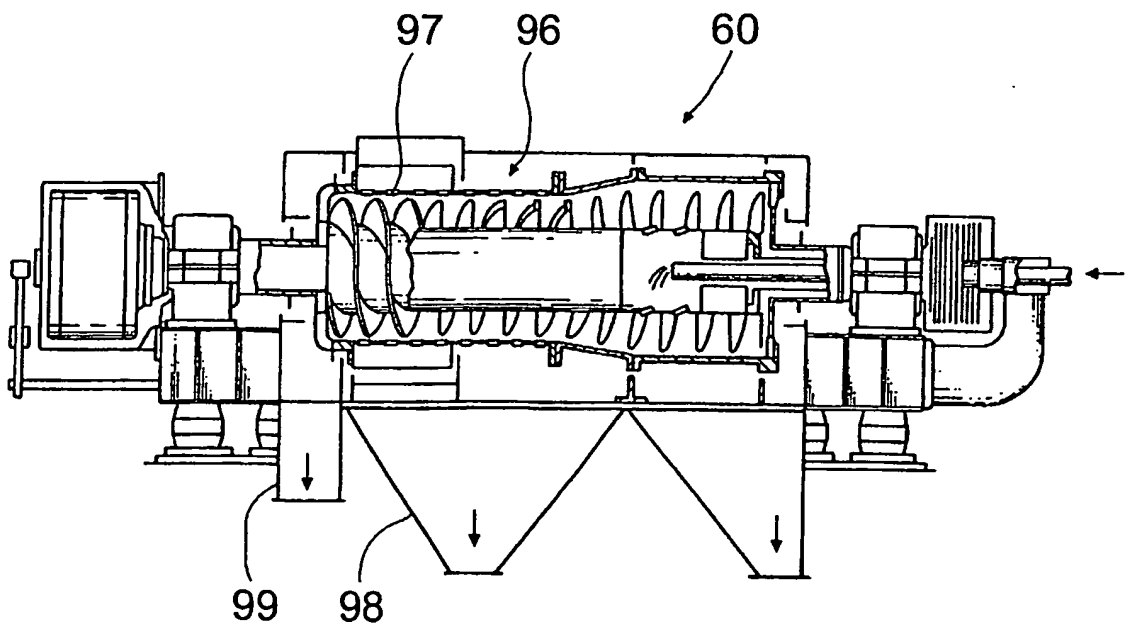

Fig. 4

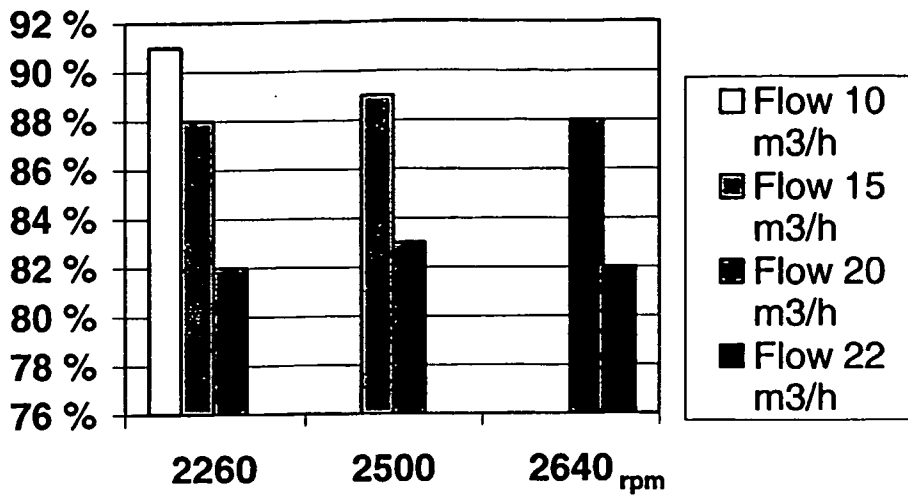

Fig. 5

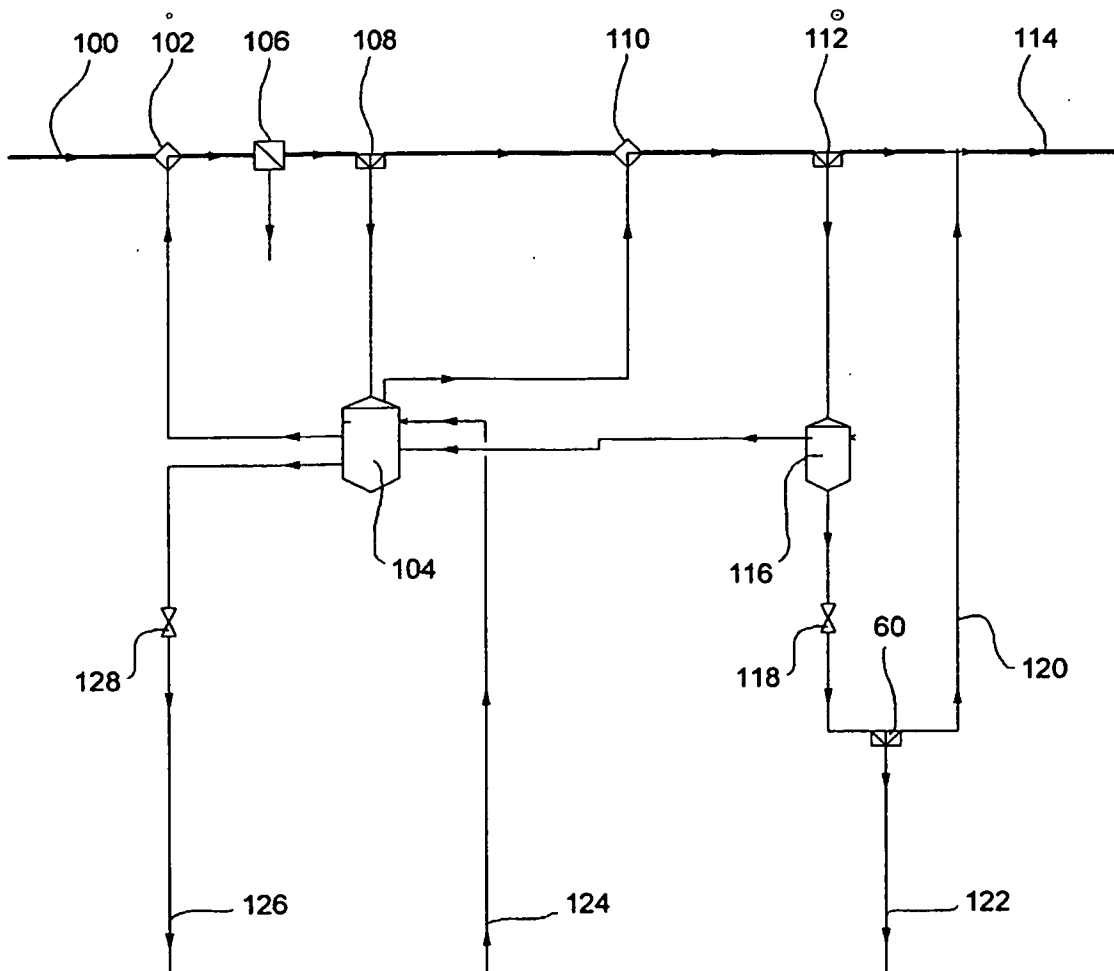

Fig. 6

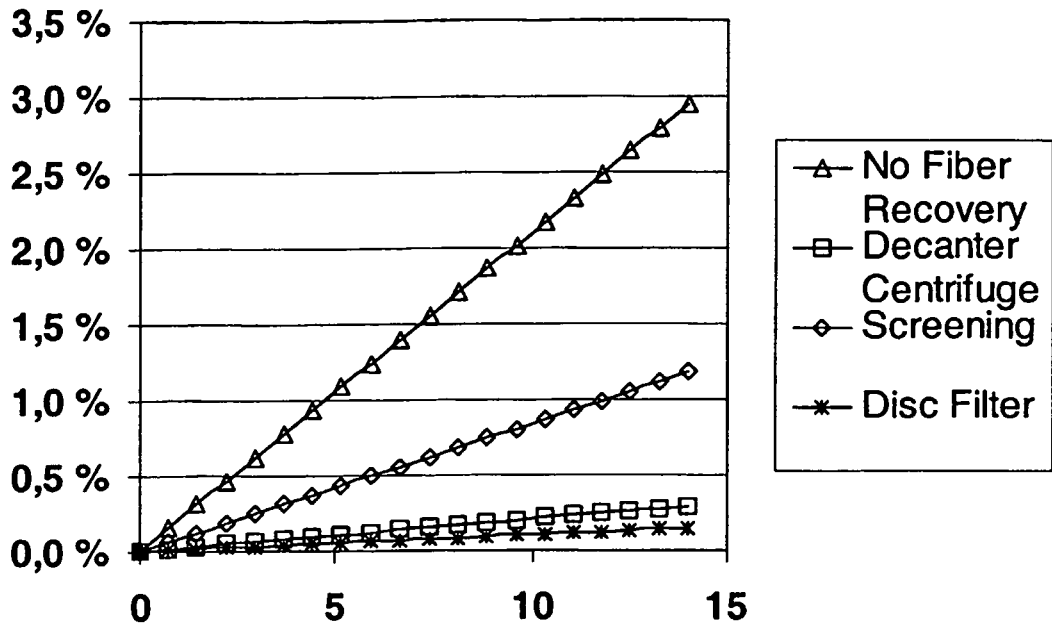

Fig. 7

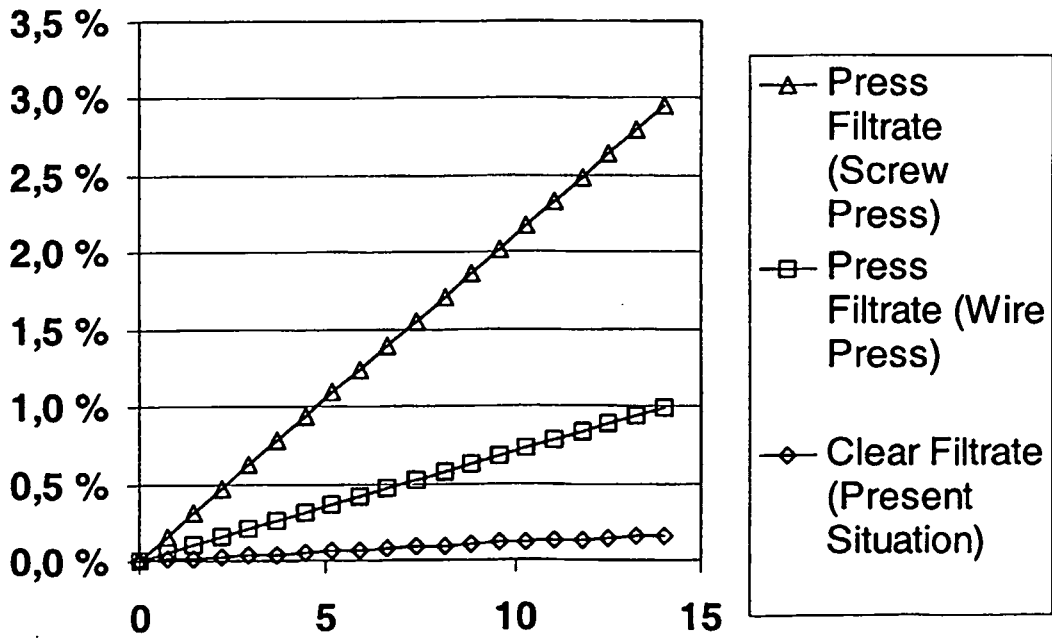

Fig. 8

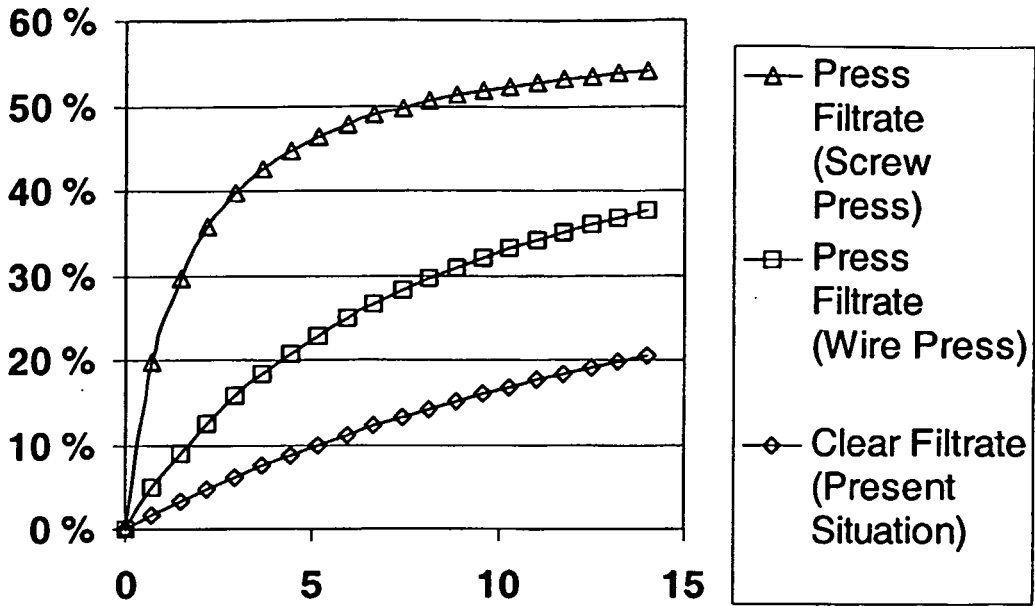

Fig. 9

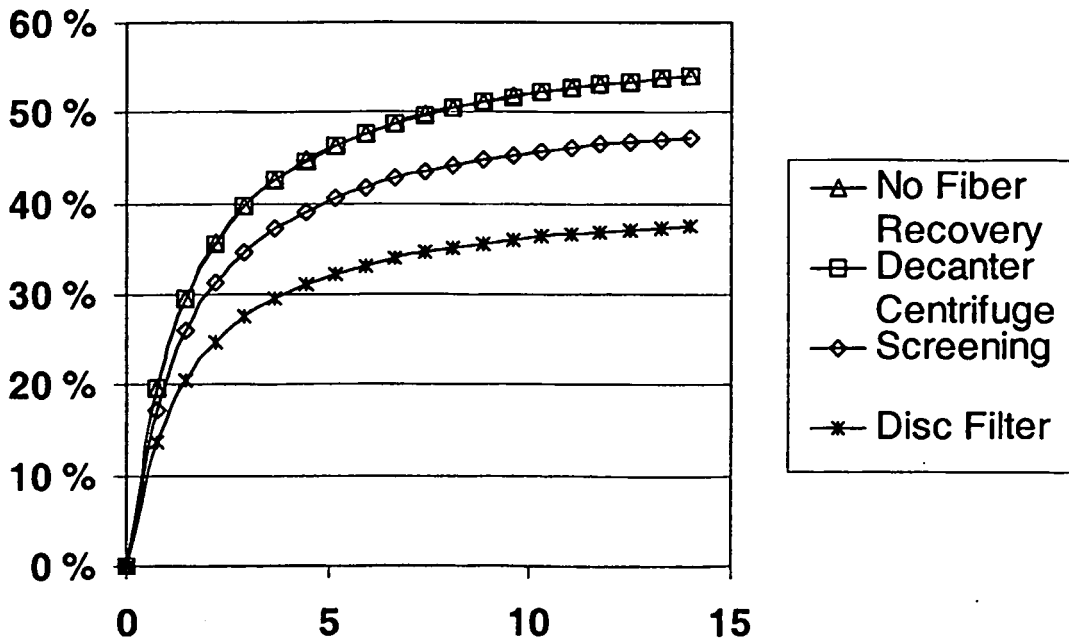

Fig. 10

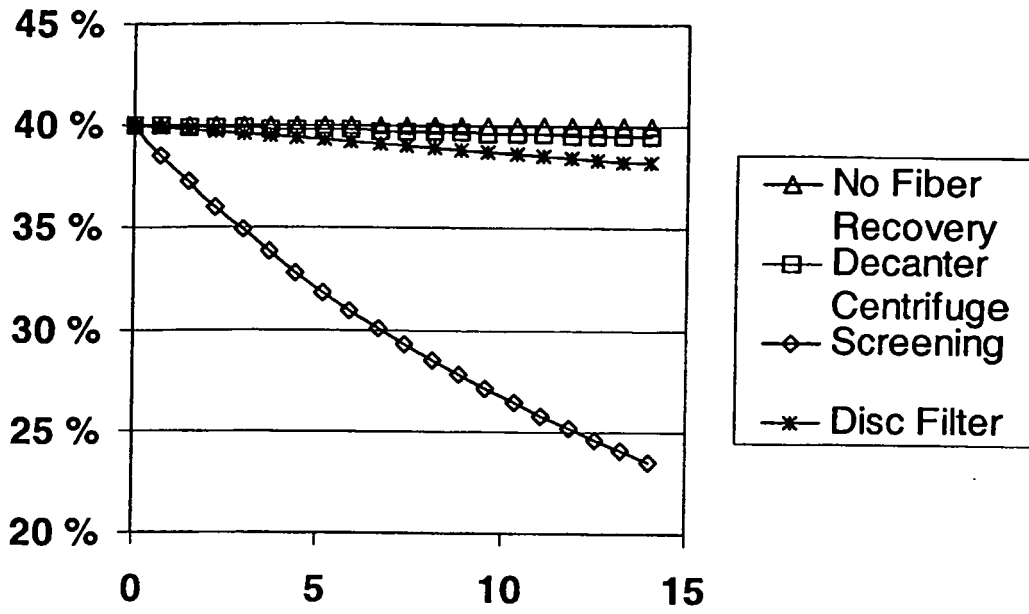

Fig. 11

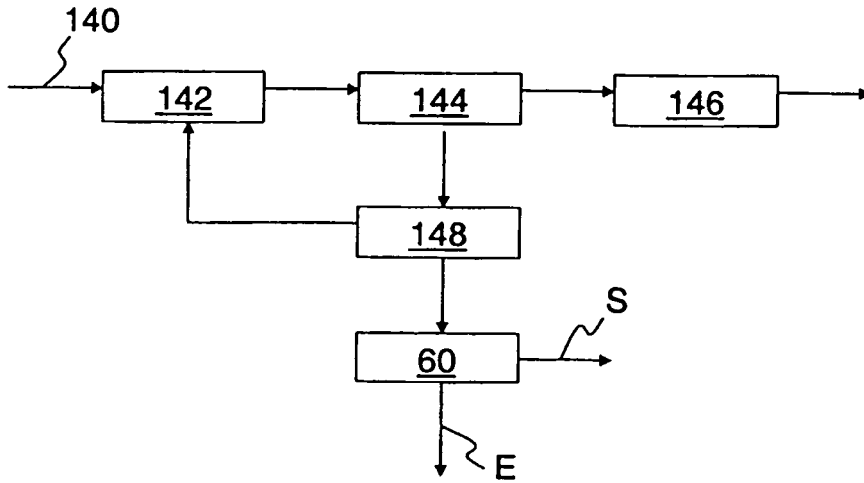

Fig. 12

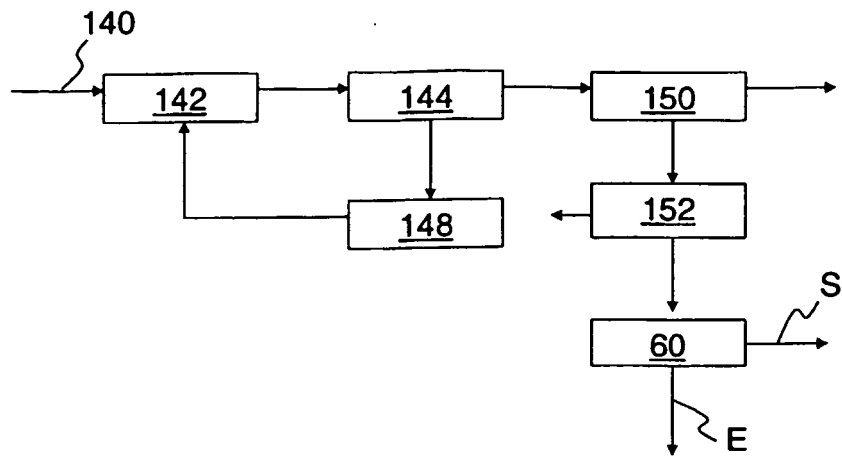

Fig. 13

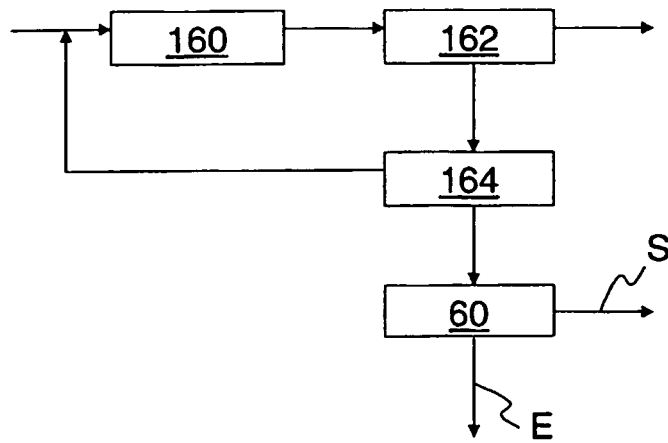

Fig. 14

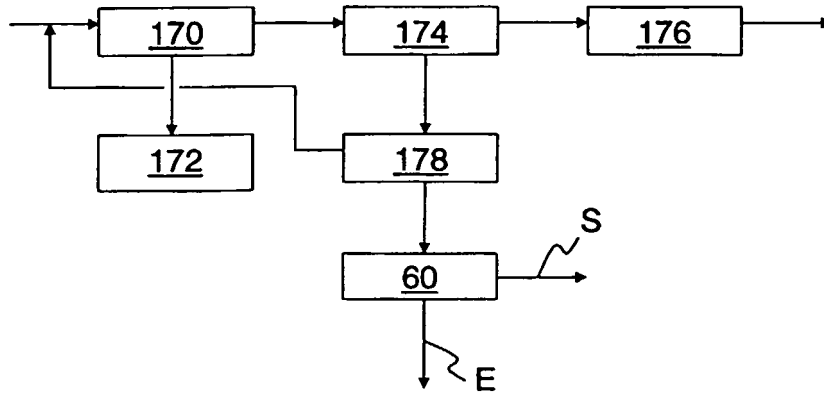

Fig. 15

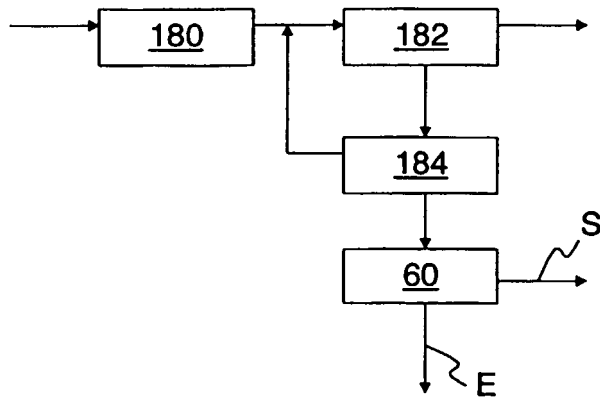

Fig. 16

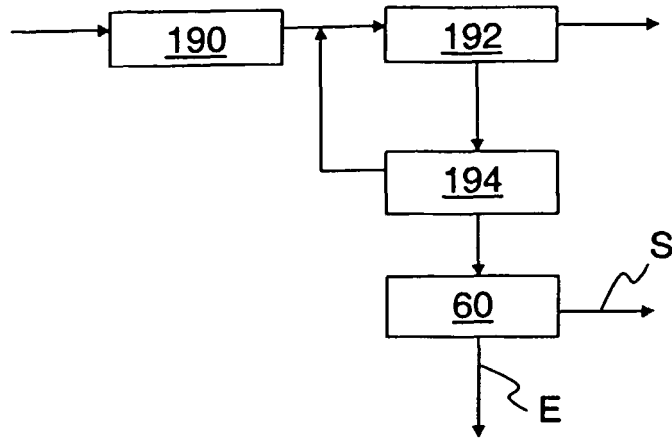

Fig. 17

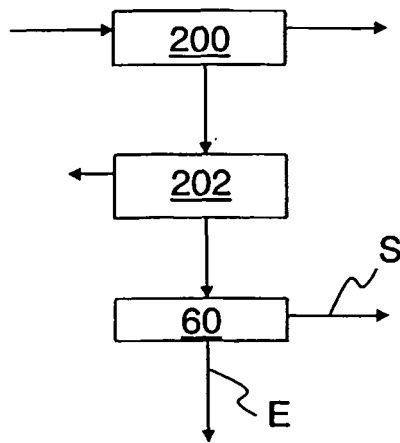

Fig. 18

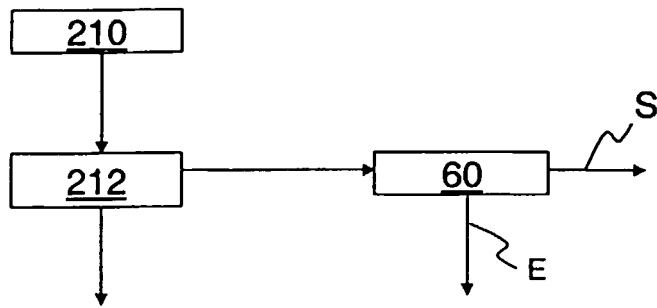

Fig. 19

REFERENCES CITED IN THE DESCRIPTION

This list of references cited by the applicant is for the reader's convenience only. It does not form part of the European patent document. Even though great care has been taken in compiling the references, errors or omissions cannot be excluded and the EPO disclaims all liability in this regard.

Patent documents cited in the description

- US 5468396 A [0015]
- EP 447742 A1 [0028]
- SE 509400 [0030]
- SE 501213 [0030]
- US 5321898 A [0032]