

W. T. BEEKMAN.

Hand Car.

No. 112,008.

Patented Feb. 21, 1871.

Fig. 1

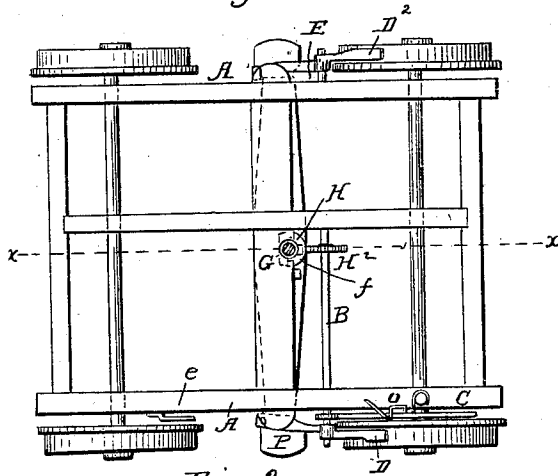

Fig. 2

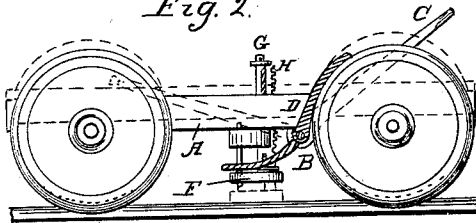

Fig. 3

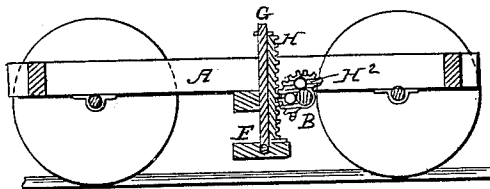
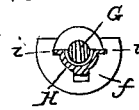

Fig. 4



Witnesses:

W. C. Sherburne
E. H. Frost

Inventor:

William T. Beekman

UNITED STATES PATENT OFFICE.

WILLIAM T. BEEKMAN, OF PETERSBURG, ILLINOIS.

IMPROVEMENT IN HAND-CARS.

Specification forming part of Letters Patent No. **112,008**, dated February 21, 1871.

To all whom it may concern:

Be it known that I, WILLIAM T. BEEKMAN, of Petersburg, in the county of Menard and State of Illinois, have invented a new and useful Improvement in Hand-Cars; and I do hereby declare the following to be a full, clear, and exact description thereof, reference being had to the accompanying drawing, making a part of this specification, in which—

Figure 1 is a top view or plan of a car with my improvement attached thereto. Fig. 2 is a side elevation of the same. Fig. 3 is a vertical longitudinal section of the same, taken in line *xx*, Fig. 1; and Fig. 4 is a detached cross-section of the shaft and rack employed in adjusting the car.

Similar letters of reference, where they occur, indicate like parts in the several figures of the drawing.

My invention has for its object to provide an improved device by which the labor of moving hand-cars to and from the track may be rendered much less; whereby the time employed in removing a car from the track on the approach of an express or other fast train is much less. Thus the safety of the men operating the same is greatly increased. And the nature of my improvement consists, first, in attaching to the frame-work of a car an adjustable bolster, so arranged that, through the medium of a rack and pinion, by the movement of a lever, the car may be raised from and turned at right angles with the track, whereby the same may be readily removed; second, in so combining or connecting the brake to the parts operating the bolster that by a forward movement of the lever the brake is brought in contact with the truck-wheels. Thus the momentum of the car is stopped, and by a backward movement of said lever the car is raised preparatory to being removed from the track.

To enable others skilled in the art to construct and use my invention, I will proceed to describe the same with reference to the drawing.

A represents the frame-work of the truck, which may be constructed in the usual manner, having its proper mechanism (not shown) for propelling the same upon the track. B is a transverse horizontal shaft, which is secured to the lower side of the frame, and so arranged

as to be capable of a reciprocal rocking movement. C is a lever, which is firmly fixed to said shaft near its outer end, and so arranged as to admit of being tilted forward or backward, and secured in position by means of hooks *e e*, attached to the sides of the frame. Said shaft has also on its outer ends a curved lever and brake, D, so attached as to freely oscillate thereon. Fixed to the opposite side of the frame is a stud or pivot, E, upon which oscillates a like curved lever and brake, D². Said levers, D and D², have their upper ends bent or curved forward, approximating to the shape of the periphery of the truck-wheel. The lower ends of said levers are bent or curved backward, the lower side of which comes in contact with the upper side, and at the outer ends of bolster F, which extends across from side to side of the track. Attached to the center of said bolster is a vertical shaft, G, extending upward through rack H, which is so arranged as to revolve thereon. Said shaft is provided with a pin passing through its upper end, which comes in contact with a washer resting upon the upper end of said rack, thus securing the same. Said rack is provided on its side with flanges *i i*, which move in guides or ways secured to the cross-piece of the frame, and at its lower end with a semi-annular flange, *f*, which comes in contact with or rests upon the upper side of bolster F, thus preventing the car from a rocking movement laterally when raised from the track.

The lower end of shaft G is constructed as shown in the drawing at L, and hinged to bolster F by means of stirrups passing over the same, the bolster being cut away to receive the foot of the shaft, thus allowing the same a rocking movement, whereby the forward end of the car may be tilted upward as the same is raised from the track. Said rack H gears with or takes into a geared sector-wheel, H², fixed upon the inner end of shaft B, whereby said rack may be moved upward or downward by a rocking movement of shaft B.

The operation of my invention is as follows: The car being in motion upon the track, power is applied to the lever C, tilting the same forward, which communicates with bolster F by means of shaft B, gear-wheel H², and rack H, thus raising the same, bringing it into contact

with the lower ends of levers D and D², and giving the same an oscillating movement, whereby the upper ends of said levers are brought in contact with the rim of the truck-wheel. Thus the motion of the car is stopped. The lever C is then reversed, as shown by dotted lines, Fig. 2, which brings the bolster F in contact with the track, and the car is raised sufficiently to admit of its being turned upon the shaft G to a right-angled position with the track. The lever C is then tilted forward, the bolster F raised, and the car is removed from the track in the shortest space of time.

I have described my invention as being applied only to hand-cars. It may also be attached to any car where a like brake and turn-table can be used.

Having thus described the nature and object of my invention and its construction and operation, what I claim as new, and desire to secure by Letters Patent, is—

1. The bolster F, provided with shaft G and rack H, in combination with the sector H², shaft B, and lever C, substantially as and for the purpose specified.

2. The levers D and D², in combination with bolster F, rack H, sector H², shaft B, and lever C, substantially as and for the purpose described.

WILLIAM T. BEEKMAN.

Witnesses:

G. H. FROST,

N. H. SHERBURNE.