

(19) **DANMARK**

(10) **DK/EP 2822876 T3**



(12)

Oversættelse af  
europæisk patentskrift

Patent- og  
Varemærkestyrelsen

- 
- (51) Int.Cl.: **B 65 D 85/804 (2006.01)**
- (45) Oversættelsen bekendtgjort den: **2016-08-22**
- (80) Dato for Den Europæiske Patentmyndigheds bekendtgørelse om meddelelse af patentet: **2016-05-18**
- (86) Europæisk ansøgning nr.: **13720557.1**
- (86) Europæisk indleveringsdag: **2013-03-05**
- (87) Den europæiske ansøgnings publiceringsdag: **2015-01-14**
- (86) International ansøgning nr.: **IB2013051747**
- (87) Internationalt publikationsnr.: **WO2013132435**
- (30) Prioritet: **2012-03-05 IT BO20120103**
- (84) Designerede stater: **AL AT BE BG CH CY CZ DE DK EE ES FI FR GB GR HR HU IE IS IT LI LT LU LV MC MK MT NL NO PL PT RO RS SE SI SK SM TR**
- (73) Patenthaver: **Macchiavelli S.r.l., Via della Fisica, 15, San Lazzaro di Savena (BO), Italien**
- (72) Opfinder: **RONDELLI, Raffaele, Via Mascagni 17, I-40050 Argelato, Italien**
- (74) Fuldmægtig i Danmark: **Holme Patent A/S, Valbygårdsvej 33, 2500 Valby, Danmark**
- (54) Benævnelse: **Kapsel til infusionsprodukter**
- (56) Fremdragne publikationer:  
**EP-A1- 1 792 850**  
**WO-A1-93/17932**



# **DESCRIPTION**

## **TECHNICAL FIELD**

**[0001]** The present invention concerns a capsule for the infusion of granular products, powdered or in leaves, such as e.g. coffee, barley, powdered milk, tea, chamomile tea, etc.

## **BACKGROUND ART**

**[0002]** Generally, the capsules for infusion products comprise a cup made of a plastic material, within which the infusion product is arranged, and a lid, also made of plastic material and arranged so that it closes the cup. The peripheral edge of the lid is welded to the upper edge of the cup by means of an apparatus of a known type, e.g. for generating ultrasounds, which carries out the welding by means of vibrations. When the capsule is inserted inside a percolation chamber of a machine dispensing drinks, hot water is injected under pressure and passes through at least one hole pierced in the lid to be mixed with the infusion product inside the cup. Then the drink comes out of the cup through at least one hole pierced in the bottom wall of the cup. In some percolator machines the capsule is arranged so that the hot water enters through the hole pierced in the bottom wall of the cup and leaves through the hole pierced in the lid.

**[0003]** The aforesaid capsules have a plurality of drawbacks.

**[0004]** In particular, during the percolation step, the upper edge of the cup is pressed between an upper body and a lower body defining the percolation chamber. In spite of this pressure, the percolation chamber does not guarantee a perfect hydraulic seal and therefore a portion of the injected water leaks out of the percolation chamber, exactly through the space defined between the two bodies of the percolation chamber pressing the upper edge of the cup between them. In order to improve the hydraulic seal, some producers use layers made of different materials to be glued on the upper and/or the lower face of the edge of the cup.

**[0005]** EP-A1-1 792 850 (TCHIBO GMBH) illustrates the preamble portion of claim 1.

## **DISCLOSURE OF INVENTION**

**[0006]** The aim of the present invention is providing a capsule for the infusion of granular products, powdered or in leaves, which lacks the aforesaid drawbacks and has a lid and an upper edge of the cup having a particular shape allowing a correct and effective hydraulic seal of the percolation chamber during the percolation step.

**[0007]** According to the present invention, there is provided a capsule for infusion products comprising:

a cup-shaped body made of a plastic material defined by a bottom wall and by a first side wall;

a lid made of plastic material arranged so that it closes said cup-shaped body;

an annular shoulder defined on the inner face of said first side wall and on which the peripheral edge of said lid is fixed;

wherein said first side wall has an upper annular edge comprising:

a first annular portion extending upwards in one piece with said first side wall;

a second annular portion extending from said first portion and defined on a substantially horizontal plane;

a third annular portion extending from said second portion and defined on a substantially horizontal plane;

an annular projection extending downwards from the lower face of said second portion so as to define, with the outer face of said first portion, an annular seat which is suited to be engaged by the upper end of a second side wall of a percolation chamber; and

a connection ring connecting said second and third portions and which, in a section view, is arched and has a concavity facing downwards.

**BRIEF DESCRIPTION OF THE INVENTION**

**[0008]** For a better understanding of the present invention it is described hereinafter an embodiment given for mere illustrative and not limitative purposes, with a reference to the annexed figures, wherein:

- figure 1 is a plant view of a cup-shaped body of a capsule produced according to the principles of the present invention;
- figure 2 is a view according to section II-II of figure 1;
- figure 3 is an enlarged view of a portion of the cup-shaped body shown in figure 2 and showing the elements of a percolation chamber; and
- figure 4 is a view of the portion shown in figure 3 undergoing a pressure by means of the elements of the percolation chamber.

**BEST MODE FOR CARRYING OUT THE INVENTION**

**[0009]** In the enclosed figures 1 and 2 a preferred embodiment of the capsule for infusion products according to the present invention is shown as a whole with reference number 1; capsule 1 is suited to be inserted in a percolation chamber and is suited to contain an infusion product. Capsule 1 comprises a cup-shaped body 2 made in one piece of a plastic material, having a slightly truncated-cone shape and defined by a side wall 3 and by a bottom wall 4. Capsule 1 further comprises a lid 5 (shown in dashed lines in figure 2) made of plastic material and fixed by interlocking or welding on the upper part of the cup-shaped body 2. In the shown example both the lid 5 and the bottom wall 4 have respective holes 6 and 7 through which the hot water enters and the drink leaves the cup-shaped body 2. It is evident that lid 5 and bottom wall 4 could have, rather than holes 6 and 7, some valves suited to open respective holes by means of water pressure, or lid 5 and bottom wall 4 could be pierced by suitable means present in the percolation chamber for creating the aforesaid holes.

**[0010]** Side wall 3 has, in correspondence of its own upper end, an inner shoulder 8 on which the peripheral edge of lid 5 abuts. Furthermore, some projections 11 extend upwards from shoulder 8. In use, lid 5 is welded on shoulder 8 by means of a device of a known type suited to generate ultrasounds for fluidizing the material undergoing these ultrasounds and in particular for fluidizing the material forming the projection 11; as known, these vibrations induce a temperature increase in the underlying areas and therefore a fusion of the plastic material. As a consequence lid 5 is welded on shoulder 8.

**[0011]** With a reference to figures 3 and 4, above shoulder 8 the cup-shaped body 2 has an annular edge 12 made of an elastically deformable plastic material and sequentially showing a first annular portion 13 extending upwards in one piece with side wall 3, a second annular portion 14 defined on a substantially horizontal plane and a third annular portion 15 defined on a substantially horizontal plane. The inner face of portion 13 together with the shoulder defines the annular seat wherein the peripheral edge of lid 5 is then fixed. An annular projection 16 extends downwards from the lower face of portion 14, said projection 16 defining together with the outer face of portion 13 an annular seat 17 open downwards; projection 16 showing in section a thickness decreasing downwards. A connection ring 18 is arranged between portion 14 and portion 15, said ring being arched in section and having a concavity facing downwards. Moreover, the upper face of ring 18 is arranged at a higher level if compared to the upper face of portion 14. The portion 15 has its own upper face at an intermediate level between the upper face of portion 14 and the upper face of ring 18. Furthermore, portion 15 has an increasing thickness starting from ring 18. Finally, as shown in figure 1, a plurality of radial indentations 21 evenly distributed along portion 15 is provided on the upper face of said portion 15.

**[0012]** Referring now to figures 3 and 4 the percolation chamber not shown in its totality has a seat 22 defined by a not shown basis wall (suitably pierced) and by a side wall 23 whose upper end has a flat and horizontal face and engages seat 17 abutting with the aforesaid end face against the lower face of portion 14. The percolation chamber has an upper plate 24 (suitably pierced) mobile between a rest position, shown in figure 3, and a working position, shown in figure 4. Plate 24 passing from the rest position to the working position presses edge 12 of cup-shaped body 2 against the upper end of wall 23. In use, plate 24 touches first the upper face of ring 18 and then the upper face of portion 14. During the downward translation of plate 24 the ring 18 is deformed and its upper face becomes substantially flat and on the same plane of the upper face of portion 14. Ring 18 substantially acts as a hinge determining the rotation of projection 16 towards wall 23 until the lower end of projection 16 abuts against the outer surface of wall 23. In the working position plate 24 abuts against the upper surface of portion 14 and of ring 18, whereas portion 15 also rotates towards wall 23. With a reference to figure 4 it can be noticed that it is provided a tight stop of

plate 24 on the upper face of portion 14 and of ring 18, a tight stop of the lower face of portion 14 on the upper end of wall 23 and a tight stop of the lower end of projection 16 on the outer face of wall 23. Now, it is clear that the pressure exerted by plate 24 on edge 12 towards wall 23 creates an effective hydraulic sealing which avoids any leakage of fluid from the inside of capsule 1 to the inside and the outside of the percolation chamber.

[0013] Finally, with a reference to figures 1 and 2, ribs 25 are formed in one piece on the inner face of wall 3, said ribs extending up to bottom wall 4 and substantially strengthening wall 3 so that this latter is not deformed during the translation of plate 24 to its working position. Preferably, cup-shaped body 2 and/or lid 5 are made of PET and/or PP which, as known, are plastic materials belonging to the family of polyolefins. Moreover, the whole capsule 1 is preferably made of a biodegradable plastic material which, as known, is defined by a plastic material suitably additivated with known substances or, as an alternative, is made using biopolymers which make capsules 1 biodegradable.

[0014] The aforesaid capsule 1 has a plurality of advantages.

[0015] In particular, the upper edge of the side wall of the cup-shaped body is shaped so that it avoids any leakage of liquid to the outside of the percolation chamber. This effective hydraulic seal was obtained by making this edge in one piece with the cup-shaped body, unlike other known capsules wherein layers of different materials are glued to the edge, with all the resulting costs.

[0016] Moreover, this particular shape allows the optimal maintenance of the hydraulic seal even when the percolation chamber of the dispensing machine is worn out, maintaining the supply and safety performances of the products capsules.

## REFERENCES CITED IN THE DESCRIPTION

This list of references cited by the applicant is for the reader's convenience only. It does not form part of the European patent document. Even though great care has been taken in compiling the references, errors or omissions cannot be excluded and the EPO disclaims all liability in this regard.

### Patent documents cited in the description

- [EP1792850A1 \[0005\]](#)

## Krav

## 1. Kapsel (1) til infusionsprodukter omfattende:

- 5 - et kop-formet legeme (2) fremstillet af et plastmateriale, defineret af en bundvæg (4) og af en første sidevæg (3); nævnte første sidevæg (3) har en øvre ringformet kant (12) tilvejebringende en første ringformet del (13) strækkende sig opad i ét stykke med nævnte første sidevæg (3) og en anden ringformet del (14) strækkende sig fra nævnte første del (13) og defineret på et i det væsentlige vandret plan;
- 10 - et låg (5) fremstillet af et plastmateriale og arrangeret for at lukke nævnte kopformede legeme (2);
- en ringformet skulder (8) defineret på den første sidevægs (3) indre flade og på hvilken nævnte lågs (5) perifere kant er fastgjort;

**kendetegnet** ved, at den yderligere omfatter:

- 15 - en tredje ringformet del (15) strækkende sig fra nævnte anden del (14) og defineret på et i det væsentlige vandret plan;
- et ringformet fremspring (16) strækkende sig nedad fra nævnte anden dels (14) nedre flade, med nævnte første dels (13) ydre flade for at definere et ringformet sæde (17), som er egnet til at være i indgreb med en øvre ende af et nedsivningkammers anden sidevæg (23); og
- 20 - en forbindelsesring (18) forbindende nævnte anden (14) og tredje (15) dele, og som, i snit, er buet og har en konkavitet vendende nedad.

2. Kapsel ifølge krav 1, **kendetegnet** ved, at nævnte rings (18) øvre flade, i en hvileposition er arrangeret på et højere niveau i forhold til nævnte anden dels (14) øvre flade, og ved anvendelse, når nævnte nedsivningskammer, efter et tryk på en plade (24), i det væsentlige det samme niveau som nævnte anden dels (14) øvre flade.3. Kapsel ifølge krav 1 og/eller 2, **kendetegnet** ved, at i snit har nævnte fremspring (16) en tykkelse, som aftager i nedadgående retning.4. Kapsel ifølge ethvert af de foregående krav, **kendetegnet** ved, at nævnte tredje del (15) i en hvileposition har sin egen øvre flade arrangeret ved et mellemliggende

niveau mellem nævnte anden dels (14) øvre flade og nævnte rings (18) øvre flade; nævnte tredje del (15) har fortrinsvis en tiltagende tykkelse med start fra nævnte ring (18).

- 5 5. Kapsel ifølge krav 4, **kendetegnet** ved, at et antal radiale fordybninger (21) er tilvejebragte på den tredje dels (15) øvre flade.
6. Kapsel ifølge mindst et af de foregående krav, **kendetegnet** ved, at nævnte øvre ringformede kant (12) er fremstillet i ét stykke sammen med nævnte kopformede legeme (2).
- 10
7. Kapsel ifølge krav 6, **kendetegnet** ved, at nævnte øvre ringformede kant (12) er fremstillet af et elastisk deformerbart plastmateriale.
- 15 8. Kapsel ifølge mindst et af de foregående krav, **kendetegnet** ved, at forstærkningsribber (25), der er fremstillede i ét stykke, er tilvejebragt på nævnte første sidevægs (3) indre flade; nævnte forstærkningsribber (25) strækkende sig op til nævnte bundvæg (4).

DRAWINGS

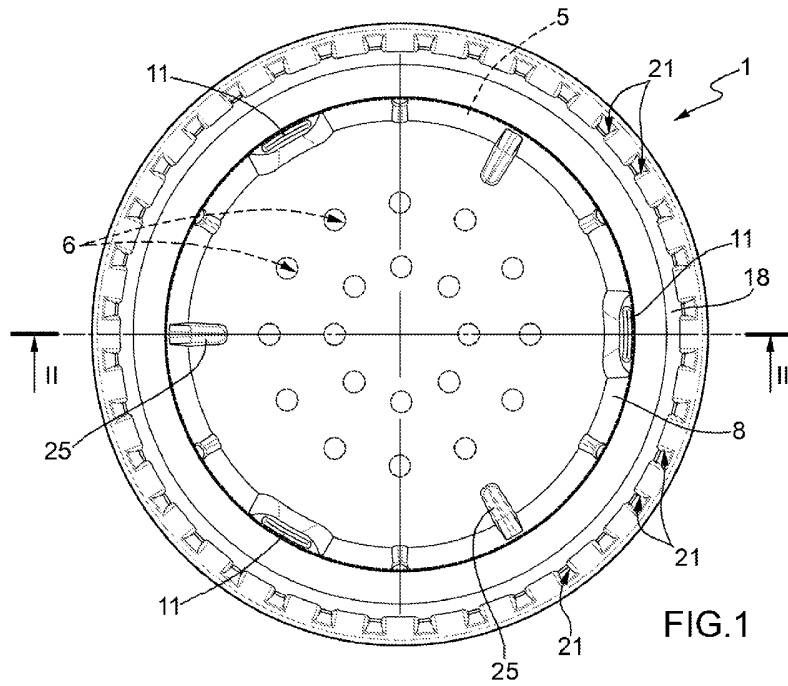
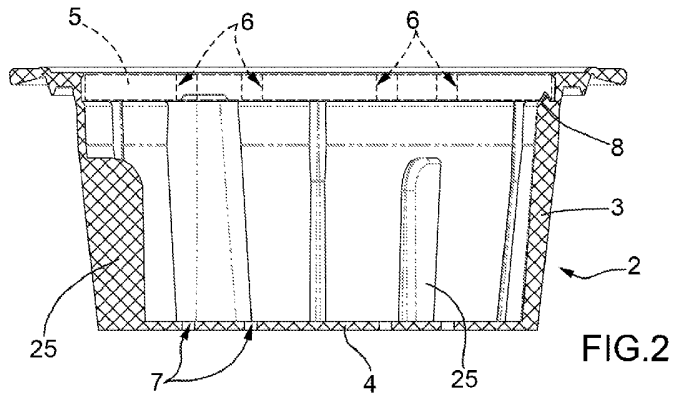

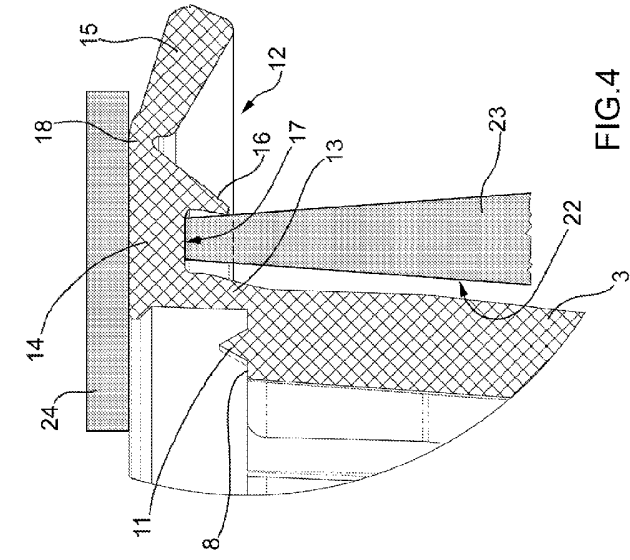

FIG. 3

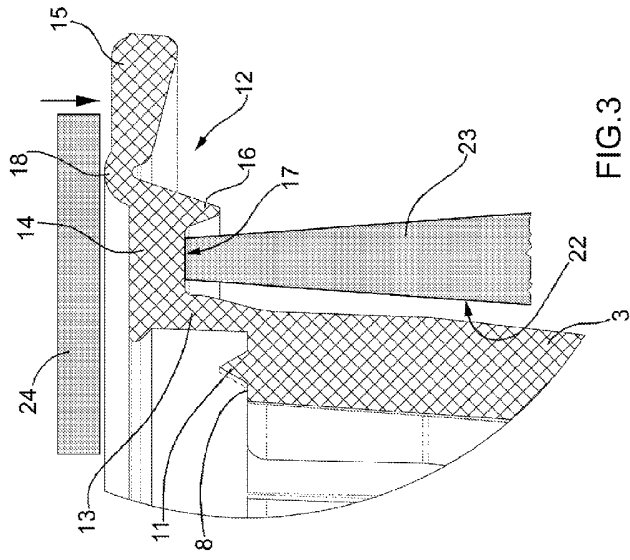

FIG. 4