

(12) STANDARD PATENT
(19) AUSTRALIAN PATENT OFFICE

(11) Application No. **AU 2004308020 B2**

(54) Title
Jack with modular mounting sleeve

(51) International Patent Classification(s)
H01P 1/04 (2006.01) **H01R 13/646** (2006.01)
H01R 13/428 (2006.01) **H04Q 1/14** (2006.01)
H01R 13/514 (2006.01)

(21) Application No: **2004308020** (22) Date of Filing: **2004.10.29**

(87) WIPO No: **WO05/046009**

(30) Priority Data

(31) Number	(32) Date	(33) Country
10/700,366	2003.11.03	US

(43) Publication Date: **2005.05.19**

(44) Accepted Journal Date: **2010.02.11**

(71) Applicant(s)
ADC Telecommunications, Inc.

(72) Inventor(s)
Skruzacek, Kenneth Allen;Khemakhem, M'hamed Anis

(74) Agent / Attorney
Davies Collison Cave, 1 Nicholson Street, Melbourne, VIC, 3000

(56) Related Art
US 2003/0134541 A1
US 5,348,491 A
US 5,876,253 A
US 2,925,577
US 6,045,378 A

(19) World Intellectual Property
Organization
International Bureau



(43) International Publication Date
19 May 2005 (19.05.2005)

PCT

(10) International Publication Number
WO 2005/046009 A1

(51) International Patent Classification⁷: **H01R 13/646**,
13/428

(74) Agent: **BRUESS, Steven, C.**; Merchant & Gould P.C.,
P.O. Box 2903, Minneapolis, MN 55402-0903 (US).

(21) International Application Number:
PCT/US2004/036016

(81) Designated States (unless otherwise indicated, for every
kind of national protection available): AE, AG, AL, AM,
AT, AU, AZ, BA, BB, BG, BR, BW, BY, BZ, CA, CH, CN,
CO, CR, CU, CZ, DE, DK, DM, DZ, EC, EE, EG, ES, FI,
GB, GD, GE, GH, GM, HR, HU, ID, IL, IN, IS, JP, KE,
KG, KP, KR, KZ, LC, LK, LR, LS, LT, LU, LV, MA, MD,
MG, MK, MN, MW, MX, MZ, NA, NI, NO, NZ, OM, PG,
PH, PL, PT, RO, RU, SC, SD, SE, SG, SK, SL, SY, TJ, TM,
TN, TR, TT, TZ, UA, UG, US, UZ, VC, VN, YU, ZA, ZM,
ZW.

(22) International Filing Date: 29 October 2004 (29.10.2004)

(25) Filing Language: English

(26) Publication Language: English

(30) Priority Data:
10/700,366 3 November 2003 (03.11.2003) US

(84) Designated States (unless otherwise indicated, for every
kind of regional protection available): ARIPO (BW, GH,
GM, KE, LS, MW, MZ, NA, SD, SL, SZ, TZ, UG, ZM,
ZW), Eurasian (AM, AZ, BY, KG, KZ, MD, RU, TJ, TM),
European (AT, BE, BG, CH, CY, CZ, DE, DK, EE, ES, FI,
FR, GB, GR, HU, IE, IT, LU, MC, NL, PL, PT, RO, SE, SI,
SK, TR), OAPI (BF, BJ, CF, CG, CI, CM, GA, GN, GQ,
GW, ML, MR, NE, SN, TD, TG).

(71) Applicant (for all designated States except US): **ADC
TELECOMMUNICATIONS, INC.** [US/US]; 13625
Technology Drive, Eden Prairie, MN 55344-2252 (US).

(72) Inventors; and

(75) Inventors/Applicants (for US only): **KHEMAKHEM,
M'hamed, Anis** [TN/US]; 5970 Chasewood Parkway,
#202, Minnetonka, MN 55343 (US). **SKLUZACEK, Ken-
neth, Allen** [US/US]; 644 Page Avenue, North Mankato,
MN 56003 (US).

Published:

— with international search report

[Continued on next page]

(54) Title: JACK WITH MODULAR MOUNTING SLEEVE

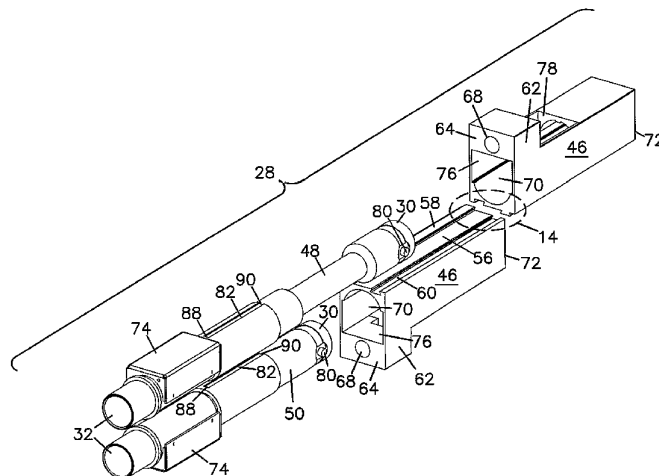

(57) Abstract: A coaxial connection assembly including a coaxial jack with a conductive outer shell with a first end and a second opposite end. The first end defines a front coaxial jack including an insulator mounted within an axial opening of the outer shell and a center conductor mounted within the insulator. The second end defines a rear coaxial jack including an insulator mounted within an axial opening of the outer shell and a center conductor mounted within the insulator. The center conductors of the front and rear jacks are electrically connected. The jack assembly is positioned within a longitudinal opening of a housing. The first end of the jack assembly extends through a first end of the housing and the second end of the jack assembly extends through a second end of the housing. The jack assembly may only be inserted within and removed from the housing through the first end. Rotation of the jack assembly within the opening is prevented. The housing includes a mounting flange extending away from the longitudinal opening adjacent the first end of the housing, with the mounting flange including an opening for receiving a fastener.



WO 2005/046009 A1



For two-letter codes and other abbreviations, refer to the "Guidance Notes on Codes and Abbreviations" appearing at the beginning of each regular issue of the PCT Gazette.

2004308020 07 Jan 2010

- 1 -

JACK WITH MODULAR MOUNTING SLEEVE

Field of the Invention

5 The present invention relates to a coaxial connection assembly; a jack pair; a method of assembling a jack pair; and a housing for a coaxial jack. For example, the present invention generally relates to mounting connector jacks to facilitate connection of communications circuits.

10 Background of the Invention

In broadcast communications equipment installations, such as in a studio or production facility, it is common to have patch panels to interconnect a variety of signal sources with a variety of downstream processing, recording and broadcast equipment. These patch panels may mount
15 jacks in paired combinations to provide input and output circuits to each piece of equipment. Also, these paired arrangements may include a single jack connected to a monitor circuit mounted adjacent to the jack pairs. Depending on the size and complexity of the installation, these patch panels may have a single paired set of jacks or may include many paired sets in a dense configuration. Other installation may include a single jack when patching with jack pairs
20 is not required or for connecting to monitor circuits in a location separate from the patching jack pairs.

Some of the paired jacks may be combined into a switching jack pair while other pairs may be two straight through jacks mounted adjacent each other. The jack pairs in a switching jack may
25 have a rigid housing about them to contain both of the jacks of the pair as well as the switching circuitry between the jacks. U. S. Patent No. 5,885, 096 shows an example switching jack. This rigid housing also provides support to the jacks themselves and helps to prevent deflection of the jacks. Individual straight through jacks mounted adjacent one another in pairs do not share such a housing. Strain from the cables attached to the jacks may cause the jacks to deflect. In
30 some cases, the jacks deflect enough to come into contact with each other or other adjacently mounted jacks.

Improvements to the jacks are desirable.

2004308020 07 Jan 2010

- 2 -

It is generally desirable to overcome or ameliorate one or more of the above described difficulties, or to at least provide a useful alternative.

5 **Summary of the Invention**

In accordance with one aspect of the present invention, there is provided a coaxial connection assembly comprising:

10 a coaxial jack assembly with a conductive outer shell with a first end and a second opposite end, the first end defining a first coaxial jack including an insulator and a center conductor, the second end defining a second coaxial jack including an insulator and a center conductor, the center conductors of the first and second jacks electrically connected;

15 a non-conductive housing including a longitudinal opening, the jack assembly slidably received within the longitudinal opening with the first end of the jack assembly adjacent a first end of the housing and the second end of the jack assembly adjacent a second end of the housing;

20 the longitudinal opening of the housing and the jack assembly each including a longitudinal guide, the guides cooperating to prevent rotation of the jack assembly within the opening;

the longitudinal opening of the housing including a stop to longitudinally limit sliding of the jack assembly within the opening;

25 the housing including a mounting flange extending away from the longitudinal opening adjacent the first end of the housing, the mounting flange including an opening for receiving a fastener.

In accordance with another aspect of the present invention, there is provided a jack pair comprising:

30 first and second jack assemblies, each jack assembly including a first coaxial connector end and a second coaxial connector end, each of the connector ends adapted to receive and electrically mate with a coaxial connector;

first and second housings, each housing defining a longitudinal opening configured to position one of the jack assemblies within the opening with the first coaxial

2004308020 07 Jan 2010

- 3 -

connector adjacent a first end of the housing and the second coaxial connector end adjacent a second end of the housing, the housings being identically configured; the opening of each housing slidably receiving one of the jack assemblies through the first end;

5 the opening of each housing and the jack assembly within the opening each including a longitudinal guide, the guides cooperating to prevent rotation of the jack assembly;

the opening of each housing including a stop to longitudinally limit sliding of the jack assembly within the opening through the first end of the housing and prevent
10 removal of the jack assembly through the second end of the housing;

each housing including an outer face including a longitudinal ridge and a longitudinal groove, the ridge and the groove of the first housing slidably received within the groove and ridge, respectively, of the second housing to releasably hold the outer faces of the first and second housings together;

15 each of the housings including a mounting flange opposite the outer face adjacent the first end of each housing, the mounting flange including an opening for receiving a fastener.

In accordance with another aspect of the present invention, there is provided a coaxial
20 connection assembly comprising:

a coaxial jack assembly with a conductive outer shell with a first end and a second opposite end, the first end defining a first coaxial jack including an insulator and a center conductor, the second end defining a second coaxial jack including an insulator and a center conductor, the center conductors of the first and second jacks
25 electrically connected;

a non-conductive housing including a longitudinal opening, the jack assembly slidably received within the longitudinal opening with the first end of the jack assembly adjacent a first end of the housing and the second end of the jack assembly adjacent a second end of the housing;

30 means for preventing rotation of the jack assembly within the opening of the housing;

2004308020 07 Jan 2010

- 4 -

means for retaining the jack assembly within the opening of the housing, the retaining means permitting insertion of the jack assembly through the first end of the housing and preventing removal of the jack assembly through the second end of the housing;

5 the housing including a mounting flange extending away from the longitudinal opening adjacent the first end of the housing, the mounting flange including an opening for receiving a fastener.

10 In accordance with another aspect of the present invention, there is provided a jack pair comprising:

first and second jack assemblies, each jack assembly including a first coaxial connector end and a second coaxial connector end, each of the connector ends adapted to receive and electrically mate with a coaxial connector;

15 first and second housings, each housing defining a longitudinal opening configured to position one of the jack assemblies within the opening with the first coaxial connector adjacent a first end of the housing and the second coaxial connector end adjacent a second end of the housing, the housings being identically configured;

the opening of each housing slidably receiving one of the jack assemblies through the first end;

20 means for preventing rotation of the jack assembly within the opening of each housing;

means for retaining the jack assembly within the opening of each housing, the retaining means permitting insertion of the jack assembly through the first end of the housing into the opening and preventing removal of the jack assembly from the opening through the second end of the housing;

25 each housing including an outer face including a longitudinal ridge and a longitudinal groove, the ridge and the groove of the first housing slidably received within the groove and ridge, respectively, of the second housing to releasably hold the outer faces of the first and second housings together;

2004308020 07 Jan 2010

- 5 -

each of the housings including a mounting flange opposite the outer face adjacent the first end of each housing, the mounting flange including an opening for receiving a fastener.

- 5 In accordance with another aspect of the present invention, there is provided a method of assembling a jack pair comprising:

providing first and second coaxial jack assemblies, each jack assembly including a first coaxial connector end, a second coaxial connector end and a first guide in an outer shell of the jack assembly, and first and second housings, each housing
10 including a longitudinal opening with a first end and a second end, the opening of each housing including a mating guide, each housing also including a first face including a ridge and a groove, the housings being identically configured;
inserting the second coaxial connector end of the first jack assembly into the opening of the first housing through the first end of the housing;
15 engaging the mating guide within the opening of the first housing with the first guide of the first jack assembly;
positioning the first jack assembly within the opening with the first connector end adjacent the first end of the first housing and the second connector end adjacent the second end of the first housing;
20 inserting the second coaxial connector end of the second jack assembly into the opening of the second housing through the first end of the housing;
engaging the mating guide within the opening of the second housing with the first guide of the second jack assembly;
positioning the second jack assembly within the opening with the first connector
25 end adjacent the first end of the second housing and the second connector end adjacent the second end of the second housing;
slidably mounting the first housing to the second housing along the first face of each housing, the ridge and the groove of the first housing cooperating with the groove and ridge, respectively, of the second housing to hold the housing together.

30

2004308020 07 Jan 2010

- 6 -

In accordance with another aspect of the present invention, there is provided a jack pair comprising:

- 5 first and second jack assemblies, each jack assembly including a first coaxial connector end and a second coaxial connector end, each of the connector ends adapted to receive and electrically mate with a coaxial connector;
- 10 a housing defining a pair of longitudinal openings, each longitudinal opening configured to position one of the jack assemblies within the housing with the first coaxial connector adjacent a first end of the housing and the second coaxial connector end adjacent a second end of the housing, the housing defining a first housing portion and a second housing portion, the first and the second housing portions of the housing being identically configured;
- 15 the openings of the housing slidably receiving one of the jack assemblies through the first end;
- each opening of the housing including a first longitudinal guide and the jack assembly including a second longitudinal guide, the guides cooperating to prevent rotation of the jack assembly;
- 20 each opening of the housing including a stop to longitudinally limit sliding of the jack assembly within the opening through the first end of the housing and prevent removal of the jack assembly through the second end of the housing;
- the housing including a pair of opposing mounting flanges, each mounting flange being adjacent the first end of each housing portion, each mounting flange including an opening for receiving a fastener.

25 In accordance with another aspect of the present invention, there is provided a housing for a coaxial jack, the housing comprising:

- 30 a body extending from a first end to a second end;
- a longitudinal opening extending from the first end of the body to the second end of the body, the longitudinal opening sized to receive the coaxial jack through the first end;
- the opening including a longitudinally extending guide to prevent rotation of the coaxial jack within the opening;
- the opening including a stop to limit sliding of the coaxial jack within the opening;

2004308020 07 Jan 2010

- 6a -

the body including a flange extending from an outer surface of the body and extending generally perpendicular to the longitudinal opening, the flange including an opening to receive a fastener;

5 the body including an outer face opposite the flange with a parallel ridge and groove extending longitudinally from adjacent the first end to adjacent the second end, the ridge and groove configured to be slidably received by within a groove and ridge, respectively, of a body of an identically configured second housing to hold the bodies together with the first ends adjacent each other and the flanges extending generally oppositely.

10

The present invention relates generally to jacks for receiving plugs to electrically connect communications circuits. A modular housing provides support to jack assemblies mounted within the housings.

15 More specifically, preferred embodiments of the present invention relate to a coaxial connection assembly including a coaxial jack with a conductive outer shell with a first end and a second opposite end. The first end defines a front coaxial jack including an insulator mounted within an axial opening of the outer shell and a center conductor mounted within the insulator. The second end defines a rear coaxial jack including an insulator mounted within an axial opening of the outer shell and a center conductor mounted within the insulator.

20 The center conductors of the front and rear jacks are electrically connected. The jack assembly is positioned within a longitudinal opening of a housing. The first end of the jack assembly extends through a first end of the housing and the second end of the jack assembly extends through a second end of the housing. The longitudinal opening of the housing includes a key which cooperates with the outer shell of the jack to prevent rotation of the jack assembly

25 within the opening. The opening also includes a stop which positions the jack assembly within the opening. The housing includes a mounting flange extending away from the longitudinal opening adjacent the first end of the housing, with the mounting flange including an opening for receiving a fastener.

30

Preferred embodiments of the present invention further relate to a jack pair comprising first and second jack assemblies, each jack assembly including a first coaxial connector end and a second coaxial connector end, each of the connector ends adapted to receive and electrically

2004308020 07 Jan 2010

- 6b -

mate with a coaxial connector. First and second housings each define a longitudinal opening configured to position one of the jack assemblies within the opening. The housings are identically configured. The opening of each housing slidably receives one of the jack assemblies through the first end. The opening of each housing cooperates with the jack assembly within the opening to prevent rotation of the jack assembly. The opening of each housing also limits the extent of insertion of the jack assembly through the first end of the housing and removal of the jack assembly through the second end of the housing is prevented. Each housing further includes an outer face with a longitudinal ridge and a longitudinal groove. The ridge and the groove of the first housing are slidably received within the groove and ridge of the second housing. Each of the housings further include a mounting flange with an opening for receiving a fastener opposite the outer face adjacent the first end of each housing.

Still further preferred embodiments of the present invention relate to a method of assembling a jack pair. The method includes providing first and second coaxial jack assemblies and first and second housings. Each housing includes a longitudinal opening with a first end and a second end. Each housing also includes a first face including a ridge and a groove, and the housings are identically configured. The first jack assembly is slidably inserted within the opening of the first housing and a guide slot of the jack assembly engages a guide within the opening. The first jack assembly is positioned within the first housing with a first connector end extending from a first end of the housing and a second connector end extending from a second end of the housing. The second jack assembly is similarly positioned within the opening of the second housing. The first housing is mounted to the second housing along the first face with the ridge of each housing slidably received within the groove of the other housing.

25

Brief Description of the Drawings

Preferred embodiments of the present invention are hereafter described, by way of non-limiting example only, with reference to the accompanying drawings, in which:

30

FIG. 1 is a front perspective view of a broadcast communications patch panel in accordance with preferred embodiments of the present application with some jacks shown in exploded view.

2004308020 07 Jan 2010

- 6c -

FIG. 2 is an upper rear perspective view of a second embodiment of a broadcast communications patch panel in accordance with preferred embodiments of the present invention, including monitor ports.

5

FIG. 2A is an enlarged rear perspective view of a group of jacks mounted to the patch panel of FIG. 2.

FIG. 3 is a lower rear perspective view of the patch panel of FIG. 2.

10

FIG. 3A is an enlarged rear perspective view of the group of jacks shown in FIG. 4.

FIG. 4 is a perspective view of a third embodiment of a broadcast communications patch panel in accordance with preferred embodiments of the present invention, with a single row of openings.

15

FIG. 5 is an exploded perspective view of the panel of FIG. 4.

FIG. 6 is a front perspective view of a block of three jack pairs according to preferred embodiments of the present invention.

20

FIG. 7 is a front perspective exploded view of the block of jack pairs of FIG. 6.

FIG. 8 is a rear perspective exploded view of the block of jack pairs of FIG. 6.

25

FIG. 9 is a front perspective view of a jack pair in accordance with preferred embodiments of the present invention.

FIG. 10 is a front perspective exploded view of the jack pair of FIG. 9.

30

FIG. 11 is a side view of the jack pair of FIG. 9.

FIG. 12 is an end view of the jack pair of FIG. 9.

2004308020 07 Jan 2010

- 6d -

FIG. 13 is a bottom view of the jack pair of FIG. 9.

5 FIG. 14 is an enlarged view of the portion labeled 14 in FIG. 10, showing mating ridges and grooves of the housings of the jacks of the jack pair in greater detail.

FIG. 15 is a front perspective view of one of the jacks of the jack pair of FIG. 9.

10 FIG. 16 is a rear perspective view of the jack of FIG. 15.

FIG. 17 is a front perspective view of the jack of FIG. 15 with the jack assembly partially removed from the housing.

15 FIG. 18 is a rear perspective view of the jack of FIG. 16 with the jack assembly partially removed from the housing.

FIG. 19 is a front perspective view of a second embodiment of a jack pair in accordance with preferred embodiments of the present invention.

20 FIG. 20 is a front perspective partially exploded view of the jack pair of FIG. 19.

FIG. 21 is a front perspective exploded view of the jack pair of FIG. 19.

25 FIG. 22 is a front perspective view of a third embodiment of a jack pair in accordance with preferred embodiments of the present invention.

FIG. 23 is a front perspective partially exploded view of the jack pair of FIG. 22.

30 FIG. 24 is a front perspective exploded view of the jack pair of FIG. 22.

FIG. 25 is a side view of the jack pair of FIG. 22.

FIG. 26 is an end view of the jack pair of FIG. 22.

2004308020 07 Jan 2010

FIG. 27 is a bottom view of the jack pair of FIG. 22.

FIG. 28 is a switching jack as shown mounted to the patch panel of FIGS. 1, 2, and 3.

5

FIG. 29 is a front perspective view of one of the housings of the jack pair of FIGS. 9, 19 and 22.

FIG. 30 is a top view of the housing of FIG. 29.

10

FIG. 31 is an end view of the housing of FIG. 29.

FIG. 32 is a side cross-sectional view of the housing of FIG. 29 taken along line 32-32 in FIG. 31.

15

FIG. 33 is an enlarged view of the portion labeled 33 in FIG. 31 showing the groove in greater detail.

FIG. 34 is an enlarged view of the portion labeled 34 in FIG. 31 showing the ridge in greater detail.

20

FIG. 35 is a perspective view of a jack assembly in accordance with preferred embodiments of the present invention.

25 FIG. 36 is an exploded perspective view of the jack assembly of FIG. 35.

FIG. 37 is a side cross-sectional view of the jack assembly of FIG. 35 positioned within the housing of FIG. 29.

30 FIG. 38 is a perspective view of a second embodiment of a jack assembly in accordance with preferred embodiments of the present invention.

FIG. 39 is an exploded perspective view of the jack assembly of FIG. 38.

2004308020 07 Jan 2010

- 6f -

FIG. 40 is a side cross-sectional view of the jack assembly of FIG. 38 positioned within the housing of FIG. 29.

- 5 FIG. 41 is a perspective view of a third embodiment of a jack assembly in accordance with preferred embodiments of the present invention.

FIG. 42 is an exploded perspective view of the jack assembly of FIG. 41.

- 10 FIG. 43 is a side cross-sectional view of the jack assembly of FIG. 41.

FIG. 44 is a perspective view of a fourth embodiment of a jack assembly in accordance with preferred embodiments of the present invention.

- 15 FIG. 45 is an exploded perspective view of the jack assembly of FIG. 44.

FIG. 46 is a side cross-sectional view of the jack assembly of FIG. 44.

- 20 FIG. 47 is a perspective view of an alternative embodiment of a jack pair according to preferred embodiments of the present invention with a unitary housing.

Detailed Description of Preferred Embodiments of the Invention

Reference will now be made in detail to exemplary aspects of the present invention which are
25 illustrated in the accompanying drawings. Wherever possible, the same reference numbers will be used throughout the drawings to refer to the same or like parts.

Patch panels such as a panel 10 in FIG. 1, might be installed in broadcast communications production facilities. Patch panels 10 include a chassis 16 including a mounting frame 17 and a
30 panel front 18 with a plurality of pairs of openings 20. As shown, panel front 18 may be removed from frame 17 to allow different configurations of openings 20 to be included in panel 10. As shown, frame 17 is made of a durable material such as aluminum or steel to provide structural support to chassis 16. Other similar structural materials may be used for

2004308020 07 Jan 2010

- 6g -

frame 17 such as other durable or rigid metals or composite materials. Panel front 18 is molded or formed from plastic or other similar non-conductive material to facilitate the creation of the more complex features of panel front 18 for mounting a variety of devices to chassis 16. A pair of opposing mounting flanges 22 are on either side of frame 17 to facilitate mounting panel 10 to a communications equipment rack or other mounting structure in broadcast facility. Flanges 22 include openings 24 for receiving fasteners to secure panel 10 to the rack or mounting structure.

Jacks pairs 26, 28, 128 and 228 for connecting communication circuits are mounted to a rear of panel front 18. Each of these jack pairs include a front set of connectors accessible through one of the openings 20 in panel front 18 and a rear set of connectors accessible from the rear of panel 10.

The jack pairs as shown include prior art switching jack pairs 26 and straight through jack pairs 28, 128 and 228. All of these jack pairs include a pair of rear connectors 30 for linking to communications cables extending behind panel 10 and a pair of front connectors 32 for connecting to communications cables extending in front of panel 10. Switching pair 26 provides internal circuitry so that without a plug inserted within either front connector 32, an electrical path is defined between the pair of rear connectors 30. No such circuitry is provided in straight through pairs 28, 128 and 228. U.S. Patent No. 5,885,096, the disclosure of which is incorporated herein by reference, discloses a switching jack pair similar to switching jack pairs 26.

Jack pairs 28, 128 and 228 include a pair of housings 46, a long jack assembly or jack 48 or 148 and a short jack assembly or jack 50 or 150. Within each housing 46 is mounted one of the jack assemblies 48 or 148 and one of the jack assemblies 50 or 150. Jack pairs 28, 128 and 228, housing 46 and jacks 48, 148, 50 and 150 will be described in further detail below.

Referring now to FIGS. 2 and 3, an alternative embodiment patch panel 110 is shown. Panel 110 is similar to panel 10 in construction but includes a third row of openings 20 in a panel front 118 to which may be mounted monitor jacks 34. Panel front 118 is mounted in a frame 117. Monitor jack 34 also includes rear connector 30 and front connector 32 and these connectors 30 and 32 may be the same format as those of the adjacently mounted pairs 26 and 28. On a rear face 119 of panel front 118, a pair of fastener openings 36 are positioned adjacent each of the openings 20 in the monitor row and adjacent each pair of openings 20 for mounting pairs 26 and 28. Openings 36 each receive a fastener of a jack pair 26, 28, 128 or 228 or a monitor jack 34 to mount these devices to panel front 118. Similar openings 36 are also positioned on the rear of panel front 18 of panel 10. Panel front 118 is removably mounted to frame 117 to permit the configuration of openings 20 and 36 of panel 110 to be changed.

Extending rearward from frame 117 adjacent panel front 118 and mounting flanges 22 are a pair of sides 38. A tie-off bar 40 extends between the two sides 38 and provides a convenient location to tie-off cables extending to the rear connectors 30 of each of the jack pairs or monitor jacks. A similar structure of sides 38 and rear tie-off bar 40 may be added to panel 10.

As shown in FIGS. 1 to 3, rear connectors 30 are coaxial cable connectors for receiving standard coaxial BNC connectors. Other sizes and styles of coaxial connectors may be used as well. Front connectors 32 are coaxial cable connectors for connecting to standard size or mid size video-plugs. Other sizes and styles of coaxial connectors adapted to receive video plugs may be used as well. It is also anticipated that panels 10 and 110 are not limited to use in a broadcast communications environment but may also be adapted for use in other telecommunications installations where coaxial cable connections are required.

As can be seen in FIGS. 1 to 3, rear connectors 30 may be staggered either horizontally or vertically to improve access to adjacent connectors. This staggering also permits a greater density of jack pairs 26 and 28 and monitor jacks 34 to be mounted to panel 10 or 110. Alternatively, rear connectors 30 could be non-staggered where access and density of installation are not as great a concern.

Referring now to FIGS. 4 and 5, a grouping of jack pairs 26 and 28 and monitor jacks 34 mounted to rear 19 of panel front 18 of panel 110 is shown. Monitor jacks 34 are mounted to openings 20 in a monitor row 42. Jack pairs 26 and 28 are mounted in pairs of openings 20 in a row 44. Monitor 34 includes a housing 46 and either a long jack 48 or a short jack 50 mounted within an opening in housing 46.

FIGS. 5A and 5B show a third panel 210 with a single row of openings 20 with a single adjacent row of mounting openings 36. Individual jacks 234 including jack assemblies 50 mounted within a single housing 46, similar to monitor jack 34, may be mounted to panel 210. Panel 210 may provide a separate row of monitor circuits to match up with patching circuits such as shown in panel 10 of FIG. 1. Alternatively, jacks and housings may be mounted to panel 210 to provide patching or circuit connections where the number of circuits is relatively smaller and fewer jack assemblies are needed. Frame 217 includes mounting flanges 22 with openings 24 for mounting panel 210. Mounted to panel front 218 is a plurality of single jacks 234, which may be monitor jacks 34 but may also be individual patching jacks.

Referring now to FIG. 6, a module 54 including three jack pairs 28 mounted to a mounting block 52 is shown. Such a module might be used when a smaller number of patching jacks are required for a particular installation. Alternatively, module 54 might be used with a patch panel including a front face

adapted to receive and mount a plurality of modules 54 in a density similar to that of panels 10 and 110, above.

FIGS. 7 and 8 show module 54 of FIG. 6 is an exploded view. Also shown in FIG. 8 is the interconnection between housings 46 of each jack pair 28.

5 Housings 46 are identical housings which mate with each other along a face 56. Face 56 includes a ridge 58 and groove 60. Housing 46 also includes a mounting flange 62 positioned adjacent a first end 64. Ridge 58 and groove 60 are positioned and configured so that the ridge and groove of a first housing 46 cooperate with the groove and ridge, respectively, of a second housing 46 when the first and second
10 housings 46 are positioned with faces 56 and first ends 64 adjacent each other. Ridge 58 and groove 60, and the nature of their cooperation are described in further detail below.

Within an opening in mounting flange 62 of housing 46 is a captive fastener such as a screw 66. Screw 66 engages opening 36 of mounting block 52
15 and of panel front 18 to removably mount a housing 46, a monitor jack 34 or a jack pair 28. As shown in the FIGS., screw 66 is a captive screw and remains with housing 46 when disengaged from opening 36. It is anticipated that other captive fasteners may be used with housing 46, such as quarter-turn fasteners and similar fasteners.

20 FIGS. 9 to 14 illustrate jack pair 28. Referring now specifically to FIG. 10, housing 46 includes an opening 68 for receiving captive screw 66 in flange 62. Screw 66 includes threads which extend through first end 64, as shown in FIGS. 7 and 8, above. Housing 46 also defines a longitudinal opening 70 extending from first end 64 to a second end 72. Jacks 48 and 50 are received within opening 70
25 through first end 64 so that rear connectors 30 extend through and beyond second end 72. Adjacent front connector 32 of both jacks 48 and 50 is a grounding housing 74. Within grounding housing 74 is circuitry to permit a center conductor 84 (see FIG. 12) of jack 48 or 50 to make electrical contact with and ground to an outer conductive shell 86 (see FIG. 12). An insulator 85 electrical isolates center
30 conductor 84 from outer shell 86 except as the circuitry may ground the two to each other. Opening 70 includes an enlarged portion 76 adjacent first end 64 for receiving housing 74. Enlarged portion 76 does not extend through opening 70 to second end 72 and ends at an intermediate bulkhead 78.

Adjacent rear connectors 30 of jacks 48 and 50 are a pair of opposed bayonets 80 for releasably securing a BNC cable connector to rear connector 30. Each jack 48 and 50 also includes a pair of opposed guide or key slots 82. Each slot 82 includes a closed end 88 and an open end 90. Key slots 82 are oriented parallel
5 to the main axis of jacks 48 and 50 with closed end 88 toward the front connector 32 and open end 90 toward rear connector 30. Key slots 82 are located between grounding housing 74 and rear connector 30.

FIG. 14 shows the cooperating shapes of ridge 58 and groove 60. Ridge 58 includes a dovetail shape when viewed from first end 64 or from second
10 end 72. Groove 60 includes a mating shape for receiving the dovetail shape of ridge 58. Further details of these shapes are described below with regard to FIGS. 33 and 34.

Referring now to FIGS. 15 to 18, one half of jack pair 28 is shown, including shorter jack 50. As enlarged portion 76 of opening 70 of housing 46
15 extends beyond mounting flange 62 toward bulkhead 78, an open top 96 is formed, through which grounding housing 74 is visible. This open top allows maximum room for housing 74 without impeding access to screw 66. Between bulkhead 78 and second end 72 of housing 46, a pair of opposing guides or keys 92 are formed in the top and bottom of opening 70 to engage key slots 82 of jack 50 (and also of jack
20 48). Keys 92 and key slots 82 cooperate to orient jack 50 (and also jack 48) within housing 46. Bayonets 80 and key slots 82 are offset from each other about jack 50 and with keys 92 engaged in key slots 82, bayonets 80 are oriented horizontally.

Also within opening 70 are opposing bayonet slots 94. Opening 70 is smaller in dimension than the width of bayonets 80. Bayonet slots 94 allow rear
25 connector 30 to be inserted through first end 64 and extend through opening 70 beyond second end 72. Bayonet slots 94 also orient jack 50 so that key slots 82 are correctly oriented to engage keys 92 through open ends 90. When jack 50 is fully inserted and correctly positioned within housing 46, keys 92 adjacent bulkhead 78 engage closed ends 88 of key slots 82, and prevent further insertion of jack 50.

30 As shown in FIGS. 15 to 18, jacks 48 and 50 each include grounding housing 74. An alternative embodiment jack pair 128 includes jacks 148 and 150, which do not include grounding housing 74, is shown in FIGS. 19 to 21. In other respects, jack pair 128 is similar to jack pair 28. For jacks 48, 50, 148 and 150, key 92 engaging closed end 88 of key slot 82 defines the limit of insertion within

housings 46. While jacks 148 and 150 do not require enlarged portion 76 of opening 70, housing 46 is configured to be compatible with multiple types and styles of jacks 48, 50, 148 and 150, as well as other types and styles which may or may not include a grounding housing or another enlarged portion adjacent front connector 32.

5 FIGS. 22 to 27 illustrate a further alternative embodiment jack pair 228, with front connectors 32 configured to receive a mid-size video coaxial plug. In other respects, jack pair 228 is similar to jack pair 128 of FIGS. 19 to 21 and to jack pair 28 of FIGS. 9 to 14.

10 FIG. 28 shows prior art switching jack pair 26, including front connectors 32 configured to receive standard size video plugs and rear connectors 30 configured to receive BNC plugs. A pair of mounting flanges 162 extend from opposing sides of a housing 146. Flanges 162 including openings 68 for receiving a captive fastener such as screw 66, shown in FIGS. 16 to 19, above. Openings 68 are positioned so that fasteners within openings 68 may engage openings 36 of panel
15 front 18 or mounting block 52. As shown in FIGS. 1 to 5, above, jack pairs 26, 28, 128 and 128, may all be mounted to panel front 18 as part of patch panel 10 or 110, or as shown in FIGS. 6 to 8, to mounting block 52 as part of module 54.

 FIGS. 29 to 34 show housing 46 in further detail. A ledge 100 extends within opening 70 from bulkhead 78 to first end 64 and defines the
20 transition from opening 70 to enlarged portion 76. Ledge 100 also cooperates with bayonet slot 94 to permit bayonets 80 of rear connector 30 to extend through opening 70 in an appropriate orientation for key slot 82 to engage key 92. Keys 92 extend from second end 72 to bulkhead 78 and define an end wall 98 at bulkhead 78. End wall 98 engages closed end 88 of key slot 82 to define a stop. This stop sets the
25 maximum extent that a jack assembly may be inserted within housing 46.

 FIGS. 33 and 34 show groove 60 and ridge 58, respectively, in further detail. Ridge 58 includes an outer face 114 defining a maximum width 102 at an offset distance 112 from face 56 of housing 46. Ridge 58 narrows as it approaches face 56 to a minimum width of 104 adjacent face 56. Groove 60
30 includes an inner face 118 defining a maximum width 106 at inset distance 116 from face 56. Groove 60 narrows as it approaches face 56 to a minimum width 108 adjacent face 56. Ridge 58 and groove 60 are sized so that width 102 fits within width 106 with face 114 adjacent face 118, and width 104 fits within width 108. Distances 112 and 116 are generally equal so that when faces 56 of a pair of

cooperating housings 46 are adjacent, face 114 is adjacent face 118. Other similar cooperating shapes may be used for ridge 58 and groove 60 provided they join two identical housing to each other as shown for a jack pair 28, 128 or 228. This joining is accomplished by sliding the housing together longitudinally while preventing the housings from being pulled apart transversely.

The cooperation of the dovetail shape of the cooperating ridge 58 and groove 60 provide several advantages. First, these shapes tie together two housings 46 to form a housing for two jacks in a jack pair, such as jacks 48, 50, 148 and 150. The same housing 46 may be used to hold a single jack, such as shown in monitor jack 34. This reduces the number of different housings that must be produced and maintained in inventory. Secondly, the dovetail configuration locks two housings together while allowing sliding movement in a longitudinal direction. No additional fasteners for connecting the two housings 46 are required. Screws 66 of each housing 46 may then be used to mount housings 46 in a module 54 or a panel 10 or 110.

Housings 46 provide an electrically insulative sleeve about a tubular jack such as jacks 48, 50, 148 and 150 and also provide mechanical support to the jack to resist deflection due to strain from cables attached to rear connectors 30, when the cable exerts a force an angle to the jacks. Panel 110 provides a tie off bar 40 to help reduce the strain that a cable might exert on a jack. Panel 10 does not include such a feature and thus cables attached to a rear connector 30 and hanging directly downward from rear connector 30 may exert an angled force on the jack. Cables may also be pulled toward the side or top. Housing 46 is attached to panel front 18 by fastener 66 with first end 64 against rear face 19, as shown in FIGS. 1 to 5. For either jack pair 28 or for monitor jack 34, this arrangement allows housing 46 to provide additional support to resist such transverse forces. The resistance of transverse forces and the insulative sleeve of housing 46 reduce the likelihood that jacks 48 and 50 or 148 and 150 of a jack pair can be deflected enough to electrically contact each other and cause a short circuit between the two outer insulative shells 86. Housing 46 also provides support against the jacks being deflected enough to permanently deform or break the jacks.

Referring now to FIGS. 35 to 37, jack assembly 48 is shown in greater detail. A first outer housing 134 includes conductive outer shell 86 of front connector 32 as well as slot 82. Mounted within first housing 134 is insulator 85

within which center conductor 84 is mounted. Insulator 85 supports and isolates center conductor 84 from shell 86. As shown, insulator 85 is made from two identical halves or, alternatively, may be made as a single piece insulator. A second outer housing 132 includes a conductive outer shell 186 of rear connector 30.

5 Second outer housing 132 includes a knurled end 133 to aid insertion and retention within first outer housing 134. Mounted within second housing 132 is an insulator 185 within which a center conductor 184 is mounted. Insulator 185 supports and isolates center conductor 184 from shell 186. As shown, insulator 185 is made from two identical halves or, alternatively, may be made as a single piece insulator. A
10 conductive shaft 130 links center conductors 84 and 184.

Referring now to FIGS. 38 to 40, jack assembly 50 is shown in greater detail. A first outer housing 134 includes conductive outer shell 86 of front connector 32 as well as slot 82. Mounted within first housing 134 is insulator 85
15 within which center conductor 84 is mounted. Insulator 85 supports and isolates center conductor 84 from shell 86. As shown, insulator 85 includes two identical halves. Alternatively, insulator 85 may be a single piece insulator. A second outer housing 232 includes a conductive outer shell 186 of rear connector 30. Mounted within second housing 132 is an insulator 185 within which a center conductor 184 is mounted. Insulator 185 supports and isolates center conductor 184 from shell
20 186. As shown, insulator 185 includes two identical halves. Alternatively, insulator 85 may be a single piece insulator. A conductive shaft 130 links center conductors 84 and 184.

In both jack assemblies 48 and 50, grounding housing 74 combines with a flexible conductive contact member 136, a resistor 140, a pad 141 and a block
25 142 to define a selective termination device 147, as shown in FIGS. 36 and 39. Termination device 147 is mounted to first housing 134 with a first end 135 of member 136 extending through an opening 138 to contact center conductor 84. A second end 137 of member 136 is mounted to block 142 and is in contact with one end of resistor 140. The other end of resistor 140 is in electrical contact with first
30 outer housing 134 and conductive outer shell 86. When a mating plug is inserted within front connector 32, first end 135 of member 136 is displaced and is no longer in contact with center conductor 84, breaking the termination between center conductor 84 and shell 86. Termination device 147 is attached to first outer housing

132 by depressions 144 of grounding housing 74 engaging depressions 146 of housing 132.

FIGS. 41 to 43 show jack assembly 148 in greater detail. Jack assembly 148 does not include a selective termination device. Thus, a first outer housing 234 differs from first outer housing 134 in that there is no opening providing access to center conductor 84. Other aspects of jack assembly 148 are similar to those of jack assembly 48 shown in FIGS. 35 to 37.

FIGS. 44 to 46 show jack assembly 150 in greater detail. Jack assembly 150 does not include a selective termination device. Thus, a first outer housing 234 differs from first outer housing 134 in that there is no opening providing access to center conductor 84. Other aspects of jack assembly 150 are similar to those of jack assembly 50 shown in FIGS. 38 to 40.

FIG. 47 shows an alternative jack pair 328 with jack 48 and jack 50 inserted within a pair of openings 70 in a unitary housing 346. Housing 346 is similar to and includes the elements described above with regard to housing 46 with the exception of first face 56, ridge 58 and groove 60. Housing 346 is a single piece housing including both openings 70. Housing 346 provides support and strength to jacks 48, 50, 148 and 150 in a manner similar to housings 46, described above. Housing 346 is also constructed of a non-conductive material to prevent jacks 48 and 50, or 148 and 159, from deflected into contact with each other and creating a short circuit.

The embodiments of the inventions disclosed herein have been discussed for the purpose of familiarizing the reader with novel aspects of the present invention. Although preferred embodiments have been shown and described, many changes, modifications, and substitutions may be made by one having skill in the art without unnecessarily departing from the spirit and scope of the present invention. Having described preferred aspects and embodiments of the present invention, modifications and equivalents of the disclosed concepts may readily occur to one skilled in the art. However, it is intended that such modifications and equivalents be included within the scope of the claims which are appended hereto.

Throughout this specification and the claims which follow, unless the context requires otherwise, the word "comprise", and variations such as "comprises" and "comprising", will be understood to imply the inclusion of a stated integer or step or group of integers or steps but not the exclusion of any other integer or step or group of integers or steps.

The reference in this specification to any prior publication (or information derived from it), or to any matter which is known, is not, and should not be taken as an acknowledgment or admission or any form of suggestion that that prior publication (or information derived from it) or known matter forms part of the common general knowledge in the field of endeavour to which this specification relates.

2004308020 07 Jan 2010

THE CLAIMS DEFINING THE INVENTION ARE AS FOLLOWS:

1. A coaxial connection assembly comprising:
- 5 a coaxial jack assembly with a conductive outer shell with a first end and a second opposite end, the first end defining a first coaxial jack including an insulator and a center conductor, the second end defining a second coaxial jack including an insulator and a center conductor, the center conductors of the first and second jacks electrically connected;
- 10 a non-conductive housing including a longitudinal opening, the jack assembly slidably received within the longitudinal opening with the first end of the jack assembly adjacent a first end of the housing and the second end of the jack assembly adjacent a second end of the housing;
- the longitudinal opening of the housing and the jack assembly each including a longitudinal guide, the guides cooperating to prevent rotation of the jack assembly within the opening;
- 15 the longitudinal opening of the housing including a stop to longitudinally limit sliding of the jack assembly within the opening;
- the housing including a mounting flange extending away from the longitudinal opening adjacent the first end of the housing, the mounting flange including an opening for receiving a fastener.
- 20
2. The coaxial connection assembly of claim 1, wherein the longitudinal guide of the jack assembly includes a slot and the longitudinal guide of the opening includes a key, the key of the opening engaging the slot of the jack assembly to prevent rotation of the jack assembly within the opening.
- 25
3. The coaxial connection assembly of claim 1, wherein the interlocking longitudinal guides define the stop.
4. The coaxial connection assembly of claim 1, wherein the housing includes an outer face opposite the mounting flange, the face including a longitudinally extending ridge and a longitudinally extending groove, the ridge and groove may be slidably received within a groove and ridge, respectively, of an identically configured housing to hold the two housings together.
- 30

5. The coaxial connection assembly of claim 3, wherein the ridge has a dovetail shape and the groove has a mating shape for slidably receiving the ridge.

6. A jack pair comprising:

first and second jack assemblies, each jack assembly including a first coaxial connector end and a second coaxial connector end, each of the connector ends adapted to receive and electrically mate with a coaxial connector;

first and second housings, each housing defining a longitudinal opening configured to position one of the jack assemblies within the opening with the first coaxial connector adjacent a first end of the housing and the second coaxial connector end adjacent a second end of the housing, the housings being identically configured;

the opening of each housing slidably receiving one of the jack assemblies through the first end;

the opening of each housing and the jack assembly within the opening each including a longitudinal guide, the guides cooperating to prevent rotation of the jack assembly;

the opening of each housing including a stop to longitudinally limit sliding of the jack assembly within the opening through the first end of the housing and prevent removal of the jack assembly through the second end of the housing;

each housing including an outer face including a longitudinal ridge and a longitudinal groove, the ridge and the groove of the first housing slidably received within the groove and ridge, respectively, of the second housing to releasably hold the outer faces of the first and second housings together;

each of the housings including a mounting flange opposite the outer face adjacent the first end of each housing, the mounting flange including an opening for receiving a fastener.

7. The jack pair of claim 6, wherein the interlocking longitudinal guides for preventing rotation of the jack assembly within the opening includes a longitudinally extending key within the opening which engages a longitudinally extending key slot of the jack assembly.

8. The jack pair of claim 7, wherein the housing includes a pair of keys within the opening and the jack assembly includes a pair of key slots for engaging the keys.
9. The jack pair of claim 7, wherein the stop to limit the extent of insertion and prevent removal through the second end of the jack assembly includes a closed end within the key slot which engages an end of the key.
10. The jack pair of claim 6, wherein the ridge has a dovetail shape and the groove has a mating shape for slidably receiving the dovetail shape of the ridge.
11. The jack pair of claim 7, wherein the second connector end of each jack assembly is a BNC connector including a pair of opposing bayonets extending transversely from the connector and the opening includes a pair of bayonet slots for receiving the bayonets and orienting the key slot of the jack assembly with the key of the opening.
12. A coaxial connection assembly comprising:
 - a coaxial jack assembly with a conductive outer shell with a first end and a second opposite end, the first end defining a first coaxial jack including an insulator and a center conductor, the second end defining a second coaxial jack including an insulator and a center conductor, the center conductors of the first and second jacks electrically connected;
 - a non-conductive housing including a longitudinal opening, the jack assembly slidably received within the longitudinal opening with the first end of the jack assembly adjacent a first end of the housing and the second end of the jack assembly adjacent a second end of the housing;
 - means for preventing rotation of the jack assembly within the opening of the housing;
 - means for retaining the jack assembly within the opening of the housing, the retaining means permitting insertion of the jack assembly through the first end of the housing and preventing removal of the jack assembly through the second end of the housing;

the housing including a mounting flange extending away from the longitudinal opening adjacent the first end of the housing, the mounting flange including an opening for receiving a fastener.

13. The coaxial connection assembly of claim 12, wherein a captive fastener is positioned in the opening in the mounting flange.

14. The coaxial connection assembly of claim 13, wherein the fastener includes a screw.

15. The coaxial connection assembly of claim 12, wherein the means preventing rotation of the jack assembly within the longitudinal opening includes a first longitudinal guide within the opening and a mating first guide slot in the outer shell of the jack.

16. The coaxial connection assembly of claim 15, wherein the second end of the jack assembly includes a pair of opposing bayonets extending outward from the outer shell to a width greater than a width of the longitudinal opening, and the longitudinal opening of the housing including a pair of slots to permit the passage of the second end of the jack assembly through the longitudinal opening, and the first longitudinal guide within the longitudinal opening is positioned generally equidistant between the pair of slots within the longitudinal opening.

17. The coaxial connection assembly of claim 15, wherein the means for preventing rotation of the jack assembly includes a second guide opposite the first guide within the opening and the outer shell of the jack assembly includes a mating second guide slot opposite the first guide slot.

18. The coaxial connection assembly of claim 12, wherein the retaining means within the longitudinal opening includes a stop within the opening which engages a closed end of a mating slot in the outer shell of the jack, and the stop within the longitudinal opening is positioned generally equidistant between the pair of slots.

19. The coaxial connection assembly of claim 12, wherein the jack assembly includes means for selectively electrically terminate the center conductor of the front coaxial jack with outer shell.

20. The coaxial connection assembly of claim 19, wherein the center conductor of the front coaxial jack is electrically terminated to the outer shell as a normal condition and the electrical termination is broken by the insertion of a coaxial plug within the front coaxial jack.

21. The coaxial connection assembly of claim 20, wherein the means for selectively electrically connecting the center conductor of the front coaxial jack with the outer shell extends beyond the outer shell and the longitudinal opening of the housing is enlarged adjacent the first end of the housing to receive the means.

22. The coaxial connection assembly of claim 21, wherein the means for selectively electrically connecting the center conductor of the front coaxial jack with the outer shell includes a flexible conductive member in electrical contact with the center conductor when no plug is inserted within the front coaxial jack and a resistor electrically connecting the member to the outer shell.

23. The coaxial connection assembly of claim 12, wherein the housing includes a longitudinal ridge and a parallel longitudinal groove sized to receive the ridge extending from a face opposite the mounting flange, the ridge configured to be received in a groove of a second identical housing, when the housing is positioned with the first end and the face adjacent to a first end and a face of the second identical housing, respectively, so that the mounting flange of the housing extends opposite the mounting flange of the second identical housing.

24. The coaxial connection assembly of claim 23, wherein the ridges of the housing and the second identical housing have a dovetail shape and the grooves of the housing and the second identical housing have a cooperating shape to slidably receive the ridges.

25. A jack pair comprising:

first and second jack assemblies, each jack assembly including a first coaxial connector end and a second coaxial connector end, each of the connector ends adapted to receive and electrically mate with a coaxial connector;

first and second housings, each housing defining a longitudinal opening configured to position one of the jack assemblies within the opening with the first coaxial connector adjacent a first end of the housing and the second coaxial connector end adjacent a second end of the housing, the housings being identically configured;

the opening of each housing slidably receiving one of the jack assemblies through the first end;

means for preventing rotation of the jack assembly within the opening of each housing;

means for retaining the jack assembly within the opening of each housing, the retaining means permitting insertion of the jack assembly through the first end of the housing into the opening and preventing removal of the jack assembly from the opening through the second end of the housing;

each housing including an outer face including a longitudinal ridge and a longitudinal groove, the ridge and the groove of the first housing slidably received within the groove and ridge, respectively, of the second housing to releasably hold the outer faces of the first and second housings together;

each of the housings including a mounting flange opposite the outer face adjacent the first end of each housing, the mounting flange including an opening for receiving a fastener.

26. The jack pair of claim 25, wherein the means for preventing rotation of the jack assembly within the opening includes a longitudinally extending key within the opening and a longitudinally extending key slot of the jack assembly.

27. The jack pair of claim 26, wherein the housing includes a pair of keys within the opening and the jack assembly includes a pair of key slots for engaging the keys.

28. The jack pair of claim 26, wherein the means to limit the extent of insertion and prevent removal through the second end of the jack assembly includes a stop within the key slot which engages an end of the key.

29. The jack pair of claim 25, wherein the ridge has a dovetail shape and the groove has a mating shape for slidably receiving the dovetail shape of the ridge.

30. The jack pair of claim 25, wherein the second connector end of each jack assembly is a BNC connector including a pair of opposing bayonets extending transversely from the connector and the opening includes a pair of bayonet slots for receiving the bayonets and orienting the key slot of the jack assembly with the key of the opening.

31. A method of assembling a jack pair comprising:

providing first and second coaxial jack assemblies, each jack assembly including a first coaxial connector end, a second coaxial connector end and a first guide in an outer shell of the jack assembly, and first and second housings, each housing including a longitudinal opening with a first end and a second end, the opening of each housing including a mating guide, each housing also including a first face including a ridge and a groove, the housings being identically configured;

inserting the second coaxial connector end of the first jack assembly into the opening of the first housing through the first end of the housing;

engaging the mating guide within the opening of the first housing with the first guide of the first jack assembly;

positioning the first jack assembly within the opening with the first connector end adjacent the first end of the first housing and the second connector end adjacent the second end of the first housing;

inserting the second coaxial connector end of the second jack assembly into the opening of the second housing through the first end of the housing;

engaging the mating guide within the opening of the second housing with the first guide of the second jack assembly;

positioning the second jack assembly within the opening with the first connector end adjacent the first end of the second housing and the second connector end adjacent the second end of the second housing;

slidably mounting the first housing to the second housing along the first face of each housing, the ridge and the groove of the first housing cooperating with the groove and ridge, respectively, of the second housing to hold the housing together.

32. The method of claim 31, wherein the second coaxial connector end of each jack assembly is a BNC connector including a pair of opposing bayonets extending transversely from the connector and the opening includes a pair of bayonet slots for receiving the bayonets, and further comprising positioning the bayonets of the second coaxial connector end within the bayonet slots and orienting the guide slot of the jack assembly with the guide of the opening.

33. The method of claim 31, wherein the housings each include a mounting flange extending opposite the first face with an opening holding a fastener, and further comprising positioning one of the first or second housing adjacent a panel with the first connector of the jack assembly extending through an opening in the panel; and,

fastening the housing to the panel by engaging a fastener opening of the panel with the fastener held by the mounting flange.

34. The method of claim 33, wherein the fastener held by the mounting flange is a captive fastener.

35. The method of claim 31, further comprising engaging a stop within the opening of the first housing to limit the extent of insertion of the first jack assembly.

36. The method of claim 35, wherein the stop within the first opening is engaged by a closed end of the first guide of the first jack assembly.

2004308020 07 Jan 2010

- 23 -

37. A jack pair comprising:
first and second jack assemblies, each jack assembly including a first coaxial connector end and a second coaxial connector end, each of the connector ends adapted to receive and electrically mate with a coaxial connector;
- 5 a housing defining a pair of longitudinal openings, each longitudinal opening configured to position one of the jack assemblies within the housing with the first coaxial connector adjacent a first end of the housing and the second coaxial connector end adjacent a second end of the housing, the housing defining a first housing portion and a second housing portion, the first and the second housing portions of the housing
- 10 being identically configured;
the openings of the housing slidably receiving one of the jack assemblies through the first end;
- each opening of the housing including a first longitudinal guide and the jack assembly including a second longitudinal guide, the guides cooperating to prevent rotation of the
- 15 jack assembly;
each opening of the housing including a stop to longitudinally limit sliding of the jack assembly within the opening through the first end of the housing and prevent removal of the jack assembly through the second end of the housing;
- the housing including a pair of opposing mounting flanges, each mounting flange being
- 20 adjacent the first end of each housing portion, each mounting flange including an opening for receiving a fastener.
38. A housing for a coaxial jack, the housing comprising:
a body extending from a first end to a second end;
- 25 a longitudinal opening extending from the first end of the body to the second end of the body, the longitudinal opening sized to receive the coaxial jack through the first end;
- the opening including a longitudinally extending guide to prevent rotation of the coaxial jack within the opening;
- the opening including a stop to limit sliding of the coaxial jack within the opening;
- 30 the body including a flange extending from an outer surface of the body and extending generally perpendicular to the longitudinal opening, the flange including an opening to receive a fastener;

2004308020 07 Jan 2010

- 24 -

the body including an outer face opposite the flange with a parallel ridge and groove extending longitudinally from adjacent the first end to adjacent the second end, the ridge and groove configured to be slidably received by within a groove and ridge, respectively, of a body of an identically configured second housing to hold the bodies together with the first ends adjacent each other and the flanges extending generally oppositely.

5

39. The housing of claim 38, wherein the flange extends from the body adjacent the first end.

10

40. The housing of claim 38, wherein the longitudinally extending guide of the opening is a key extending into the opening.

15

41. A coaxial connection assembly substantially as hereinbefore described, with reference to the accompanying drawings.

42. A jack pair substantially as hereinbefore described, with reference to the accompanying drawings.

20

43. A method of assembling a jack pair substantially as hereinbefore described, with reference to the accompanying drawings.

44. A housing for a coaxial jack substantially as hereinbefore described, with reference to the accompanying drawings.

FIG.1

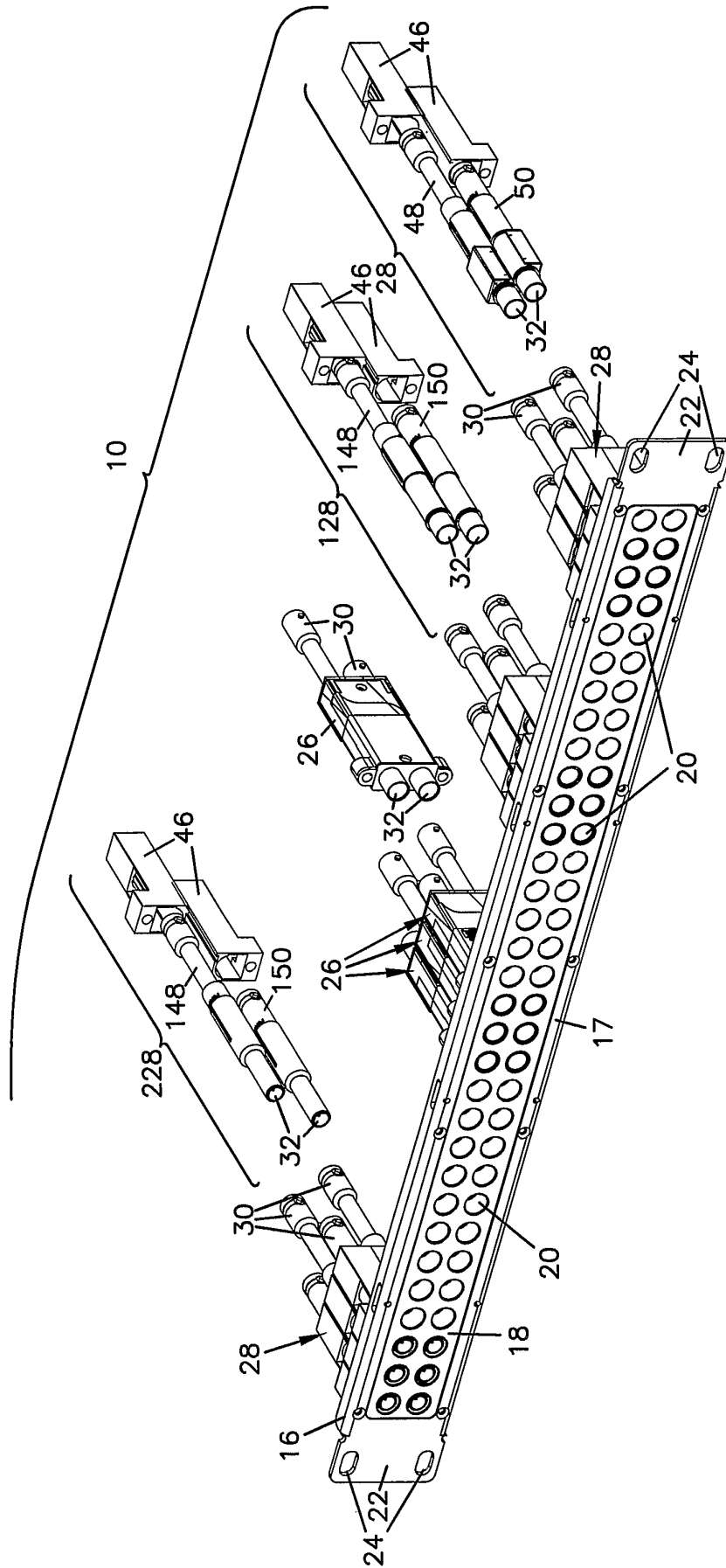

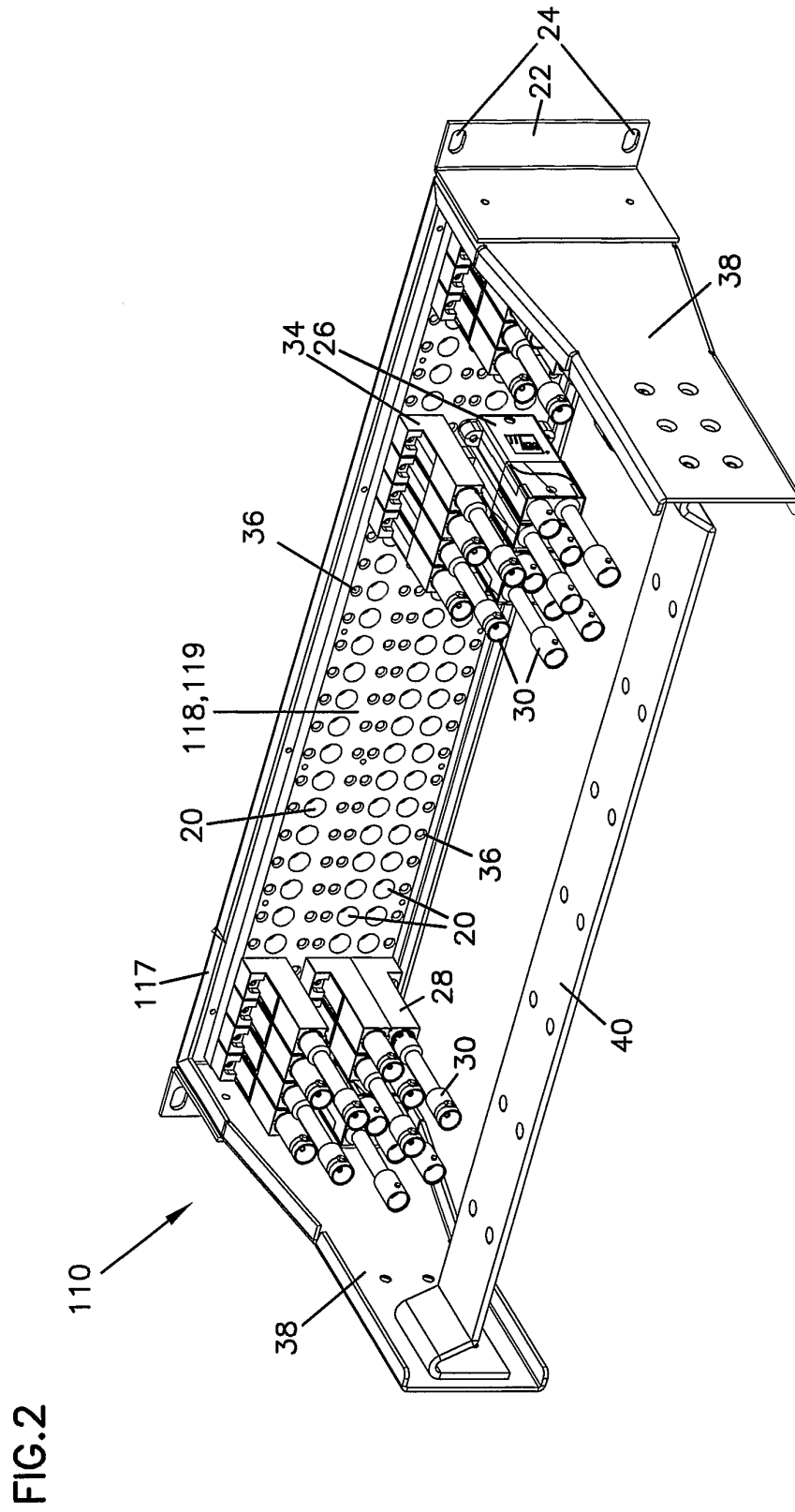

FIG.2A

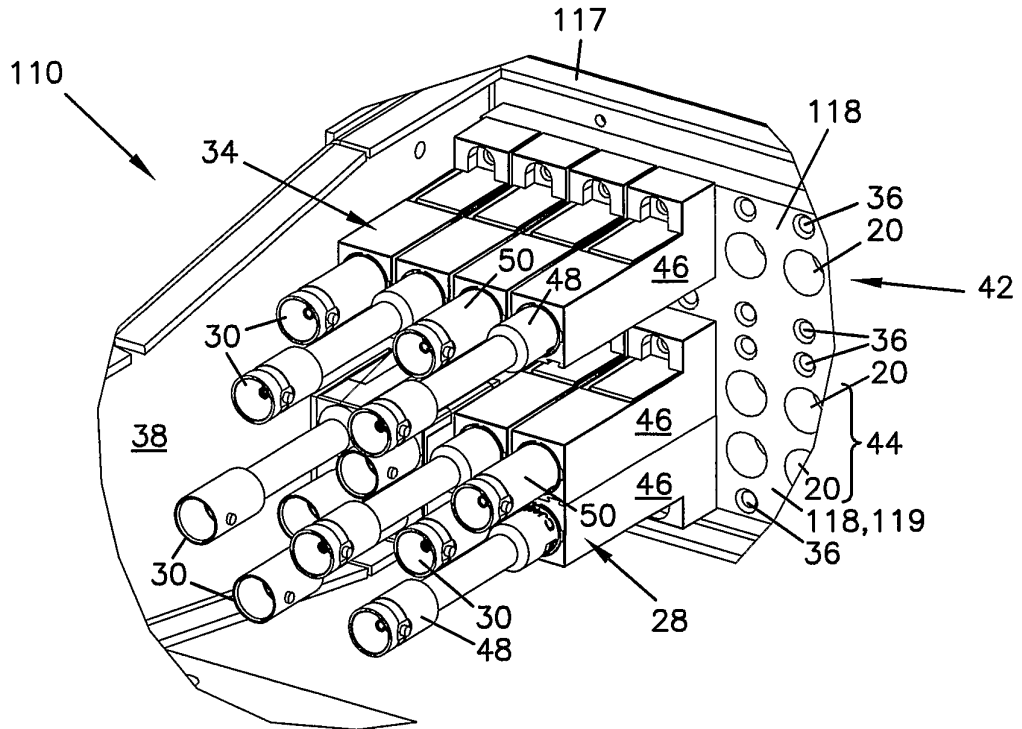
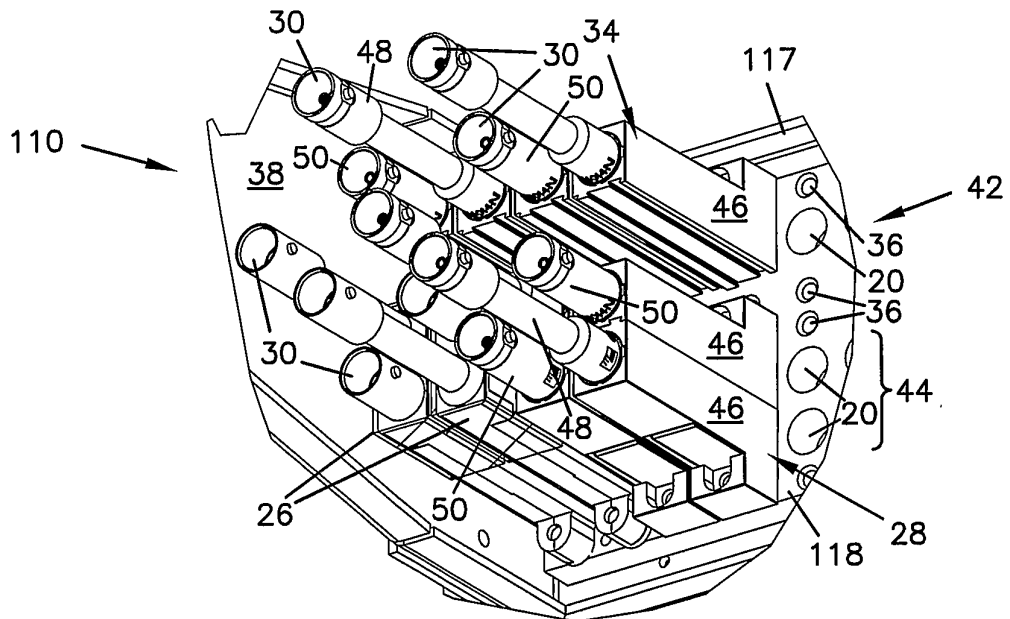
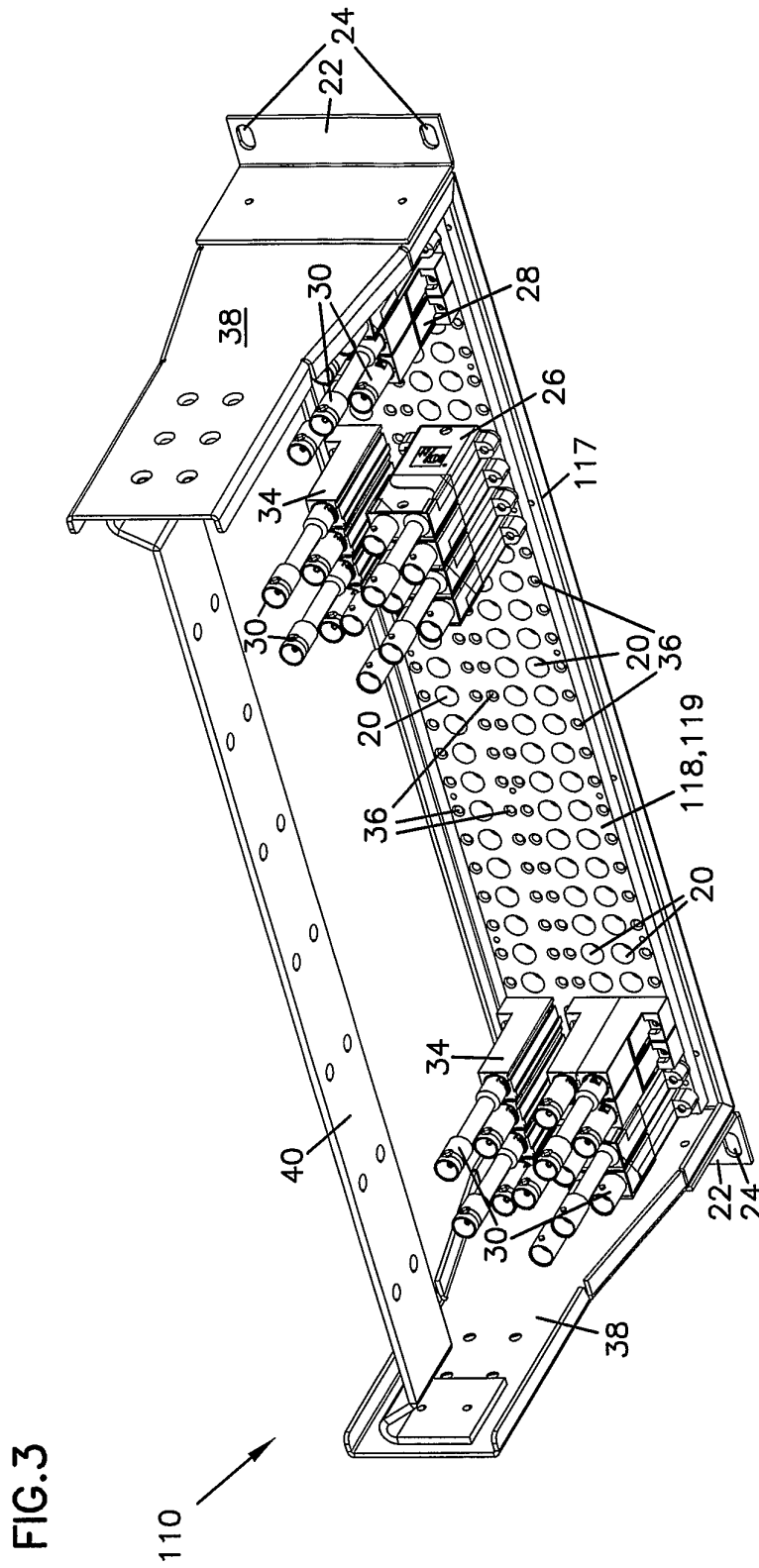

FIG.3A





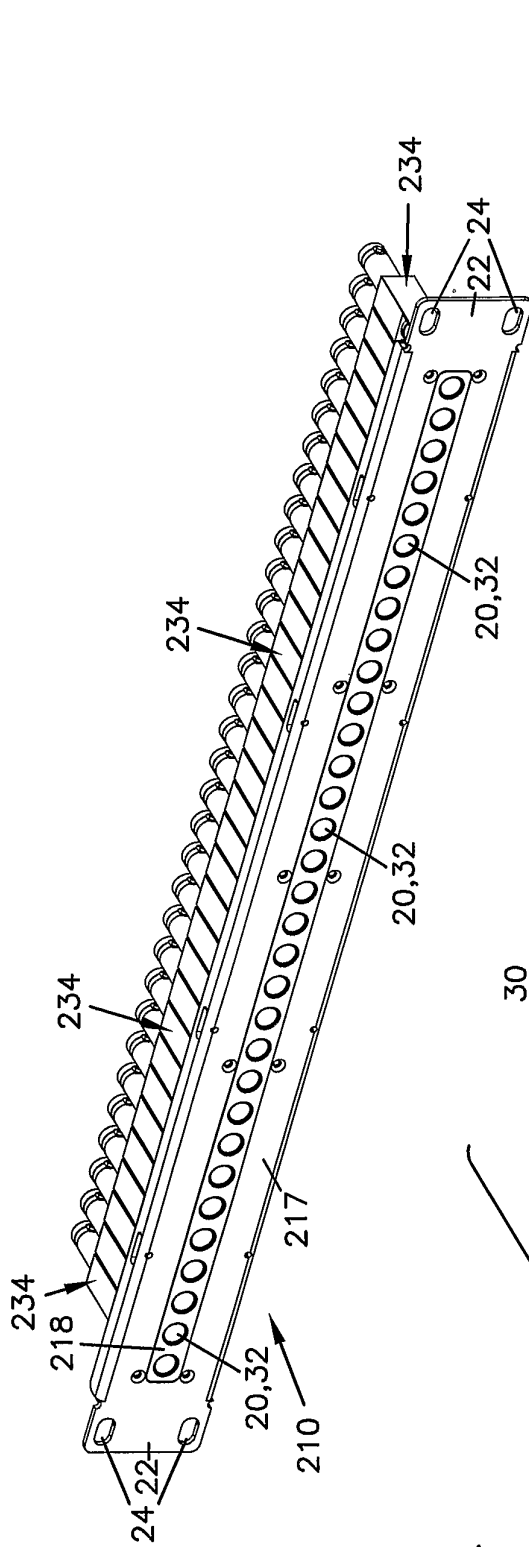

FIG. 5

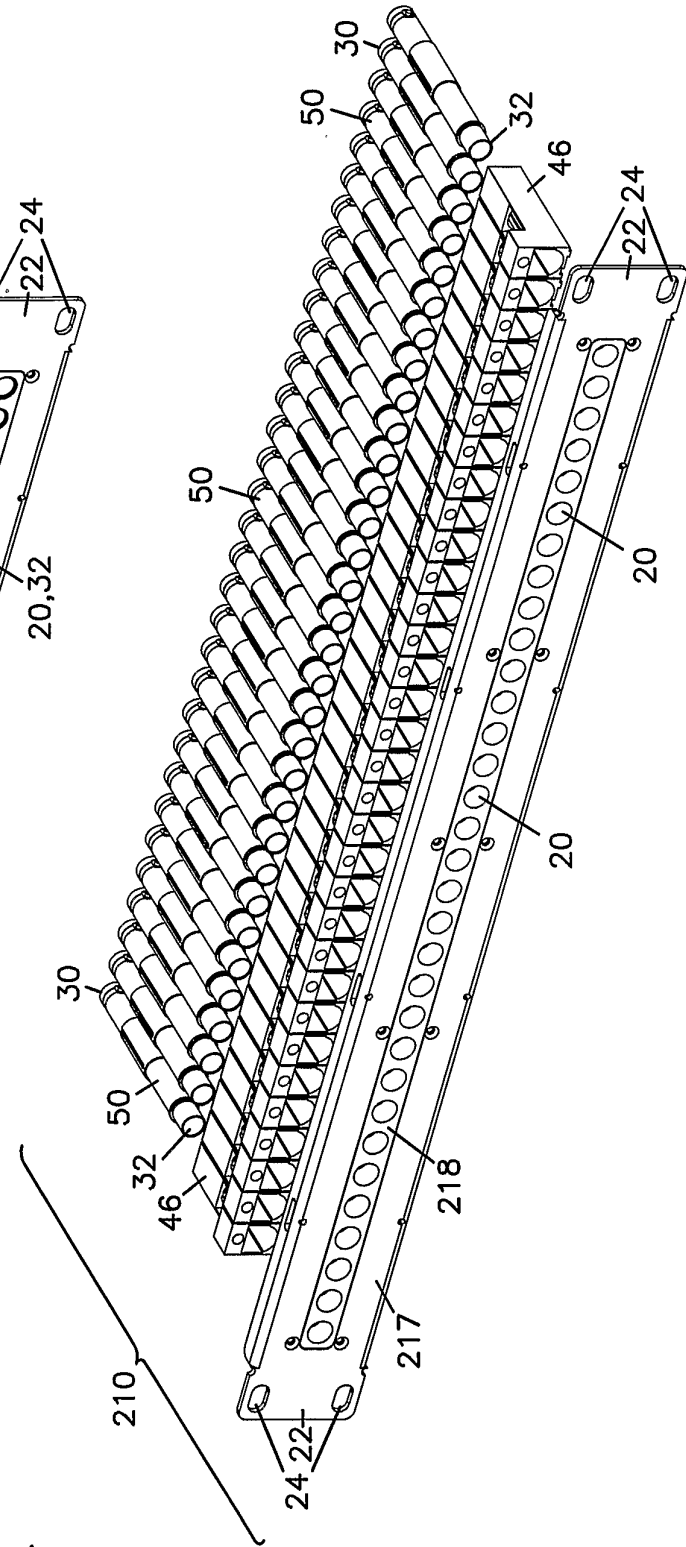

FIG. 4

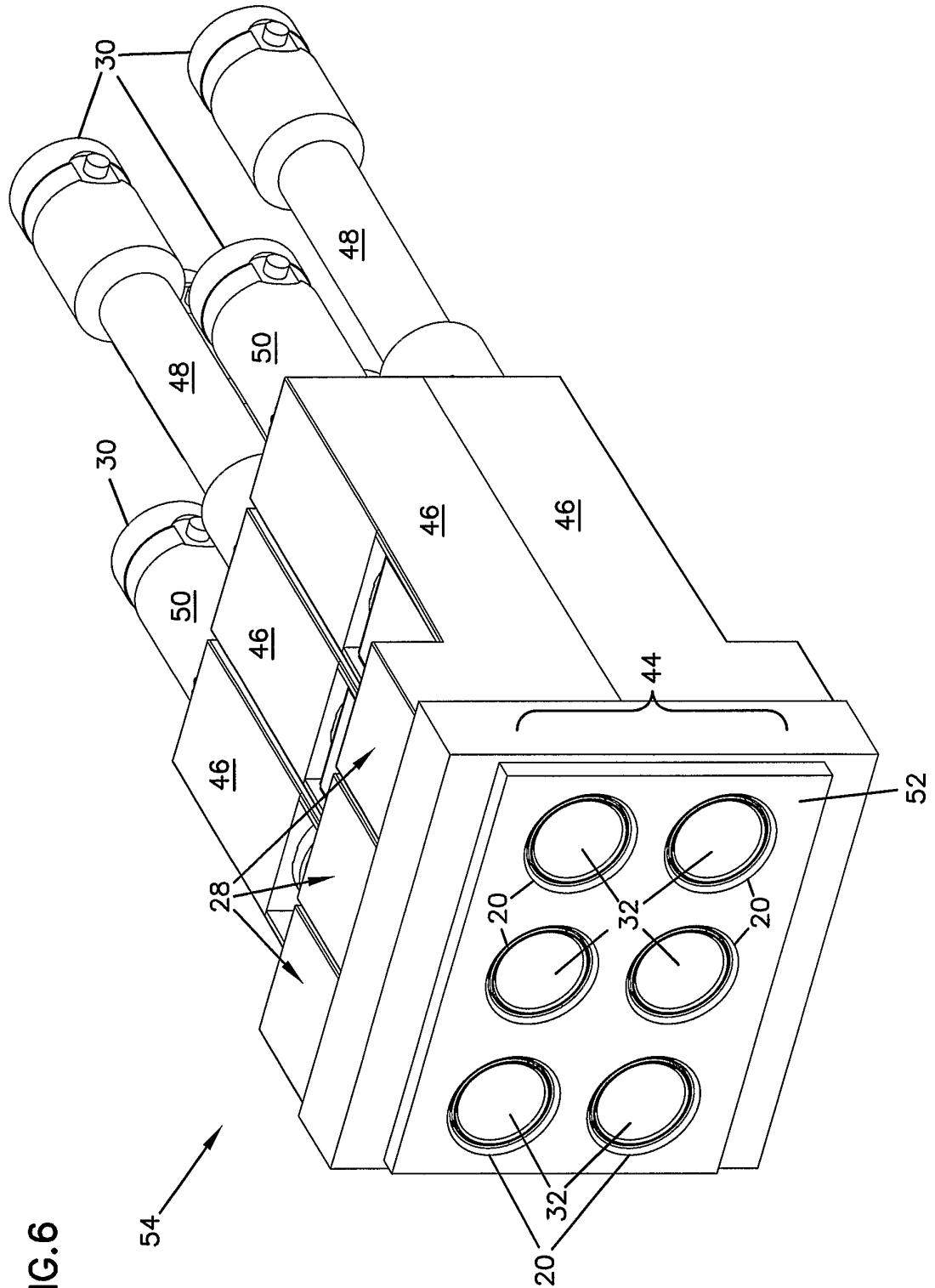
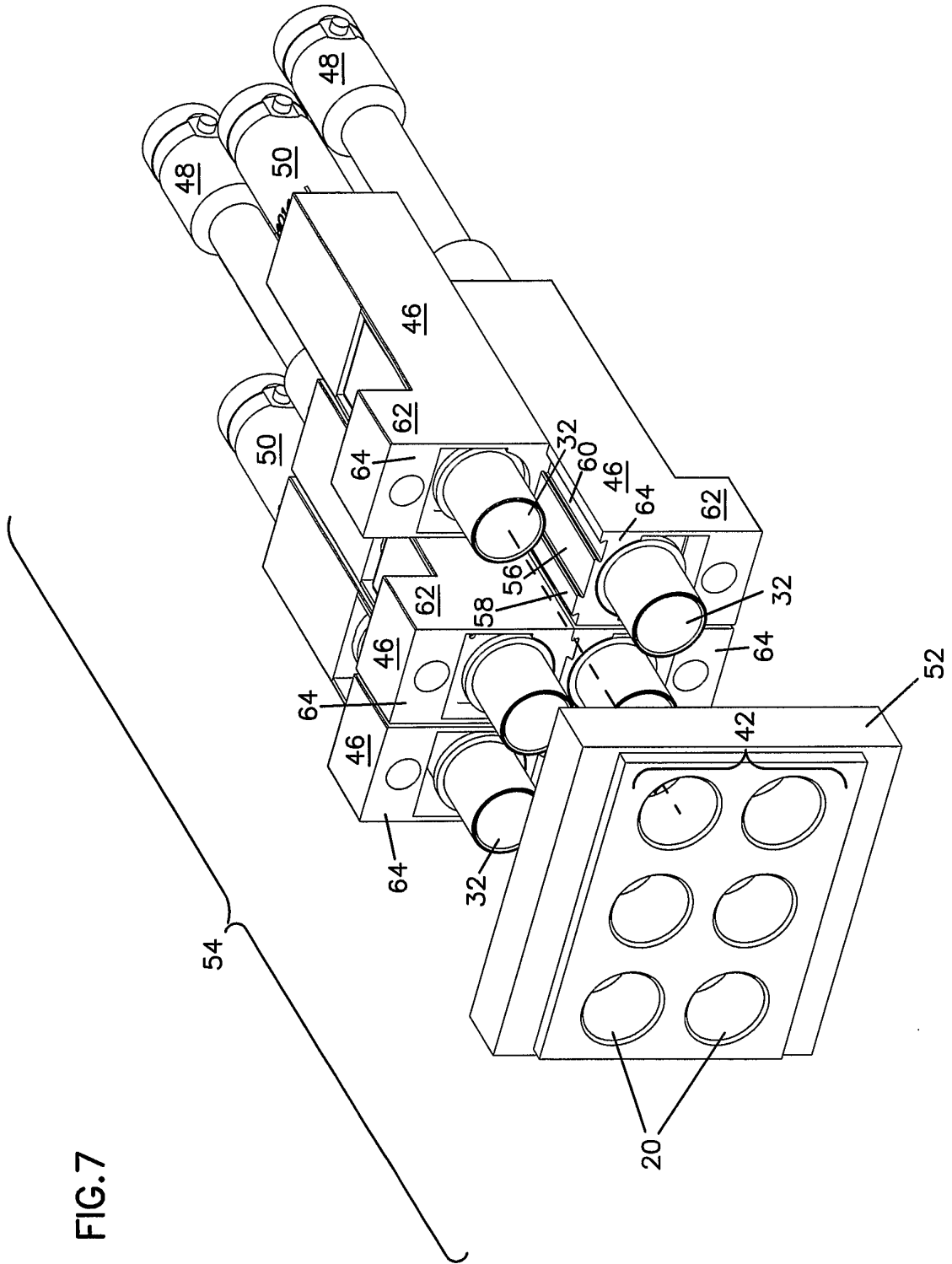

FIG. 6



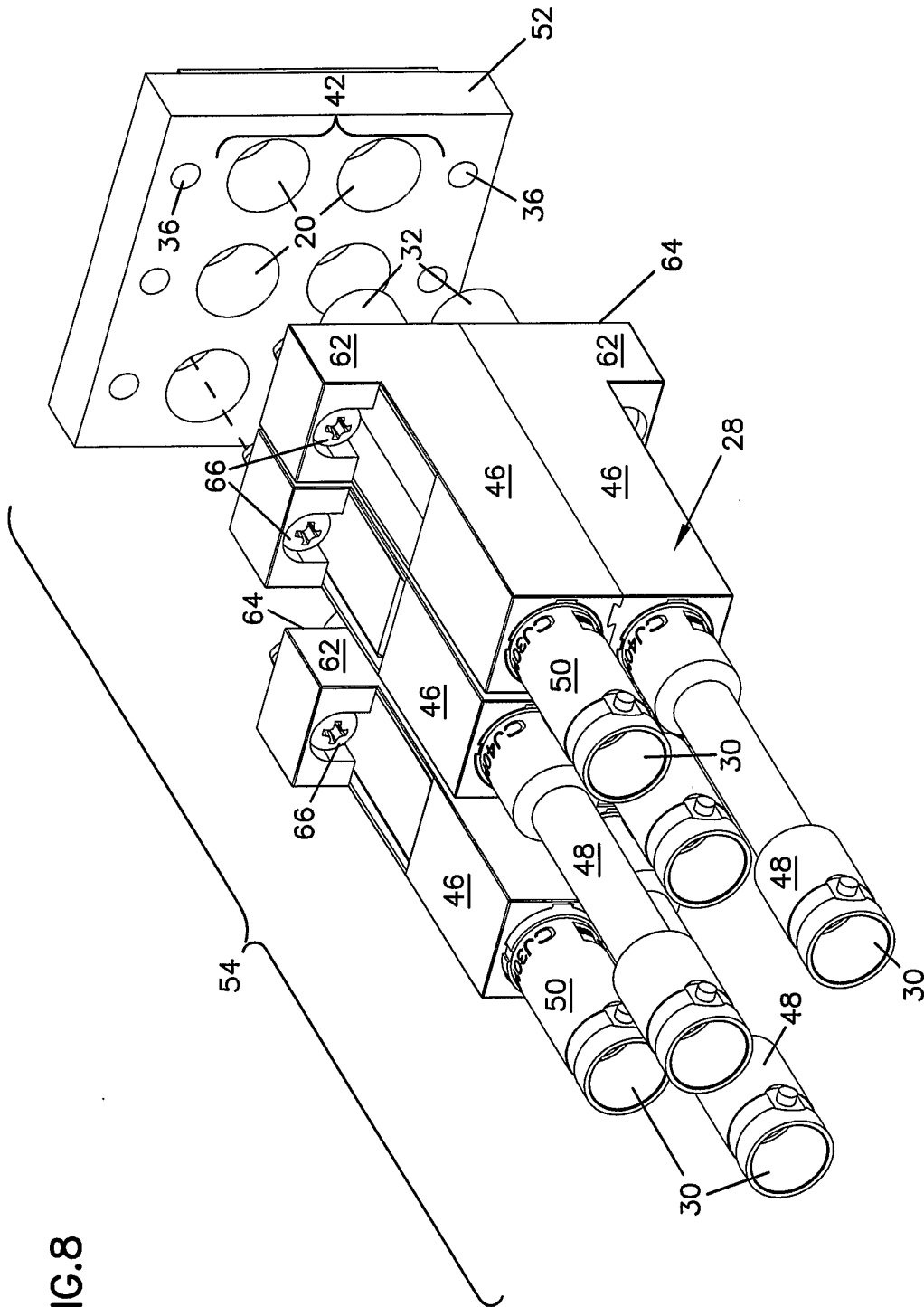

FIG.8

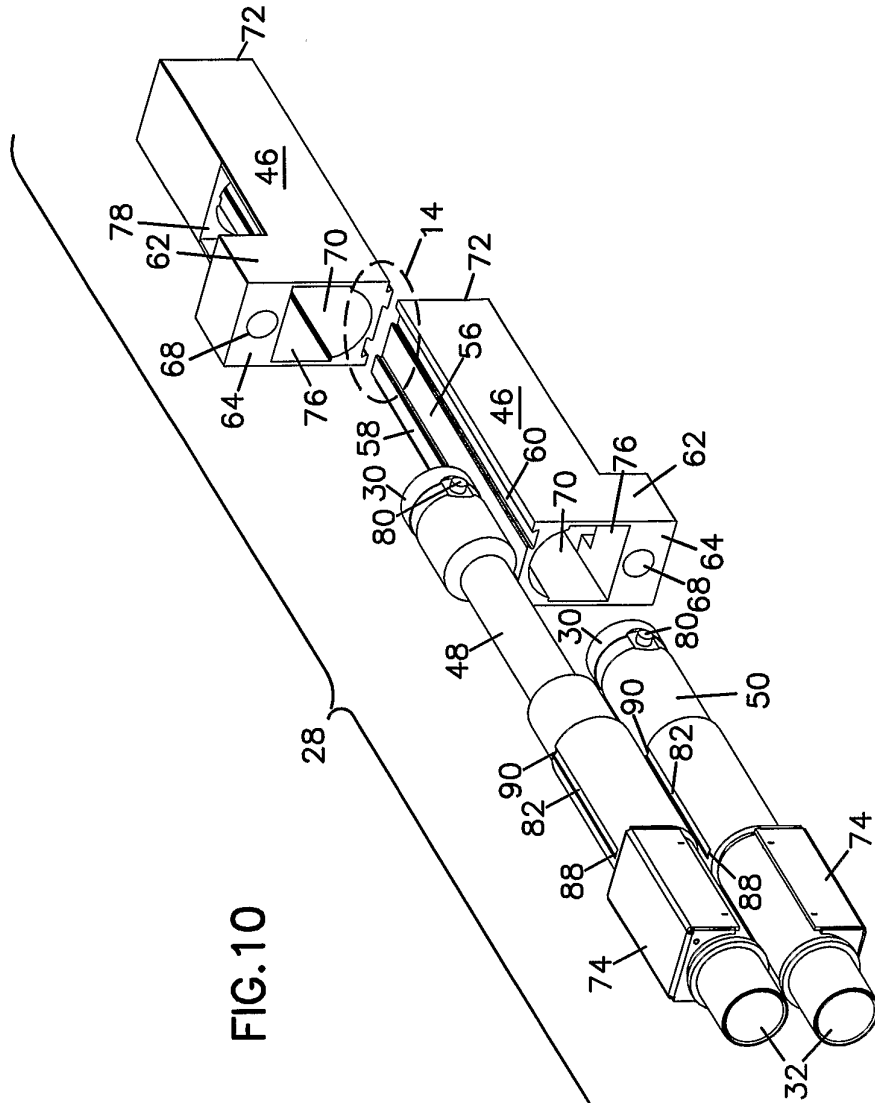

FIG. 10

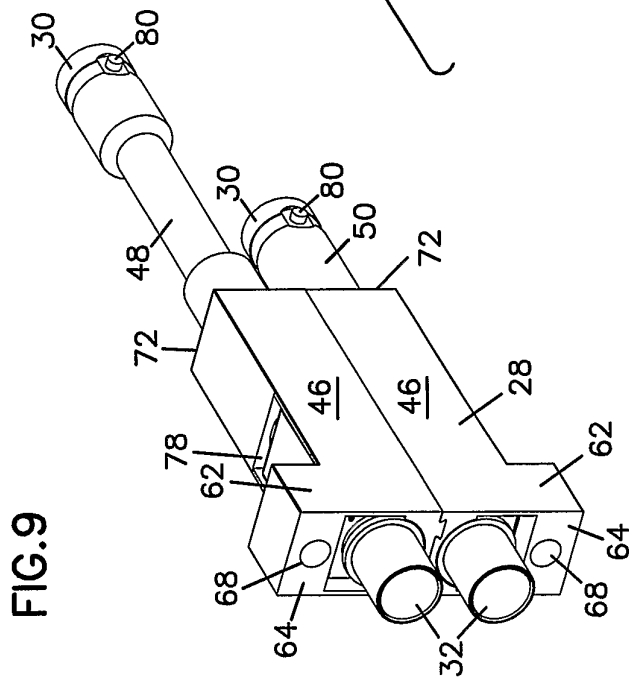
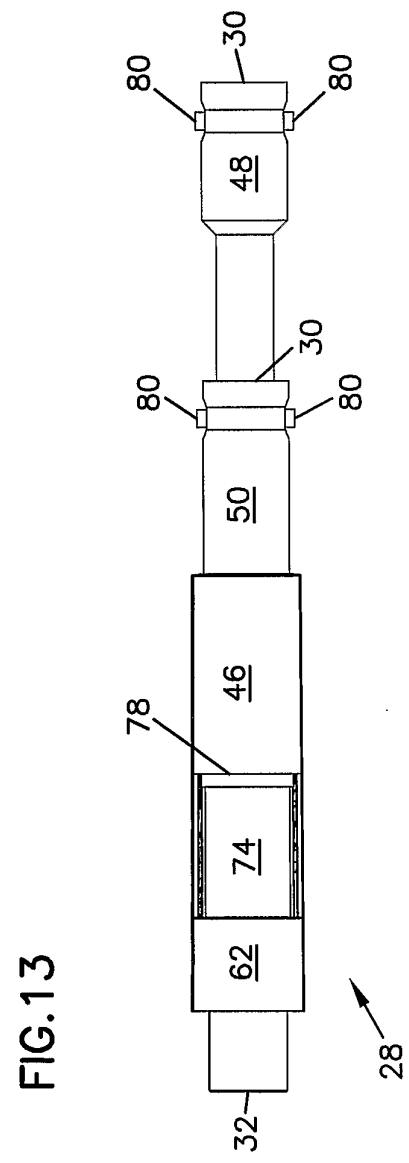
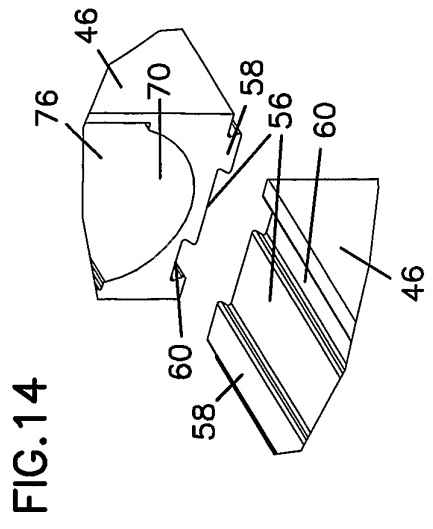
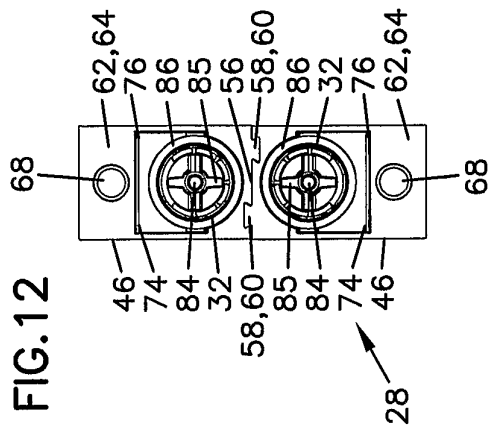
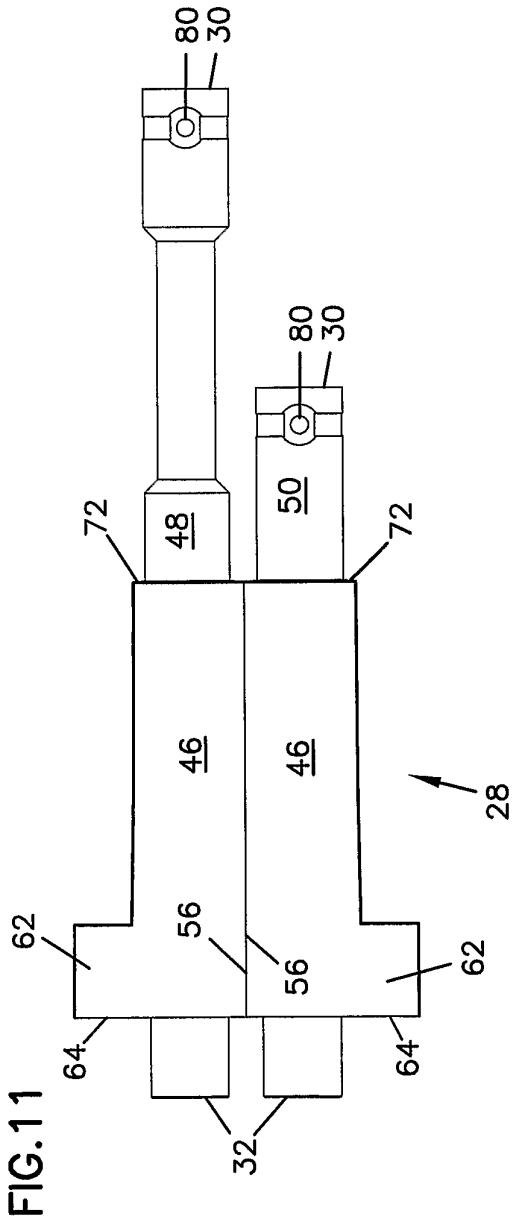

FIG. 9



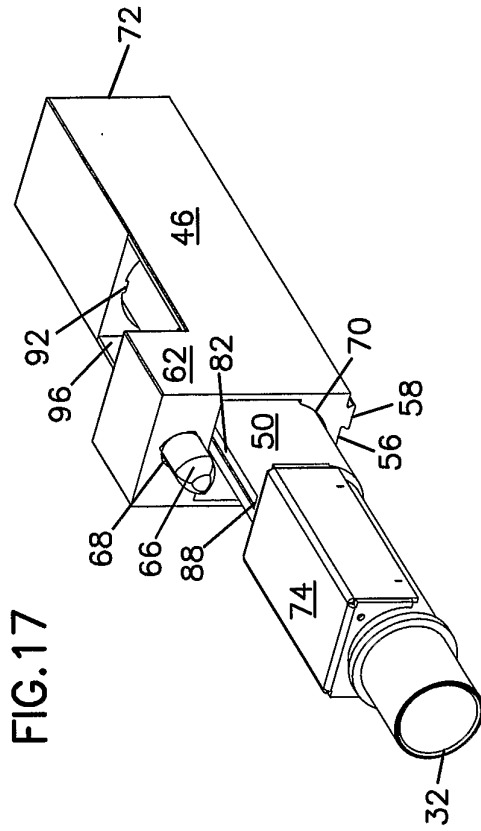

FIG. 17

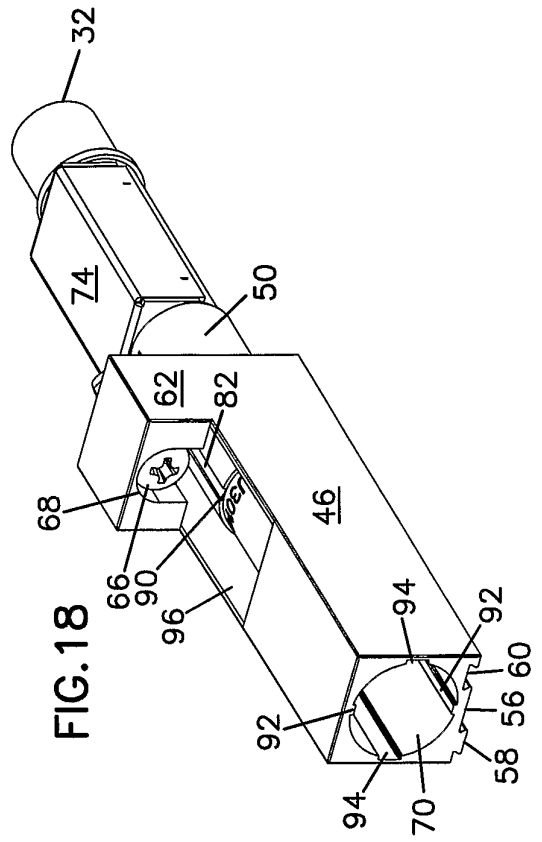

FIG. 18

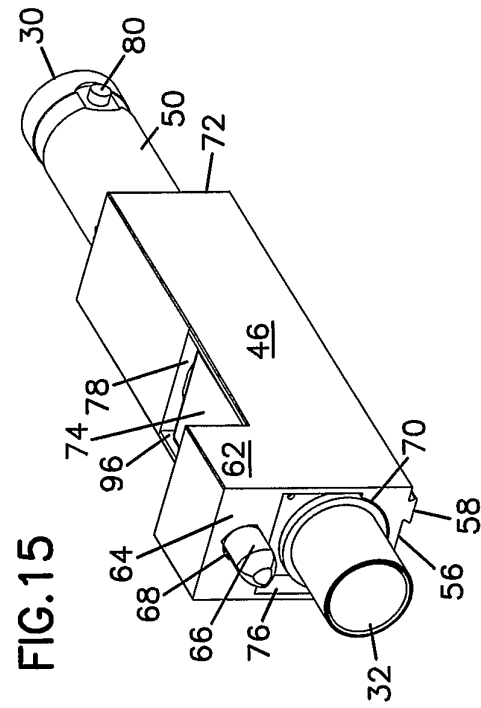

FIG. 15

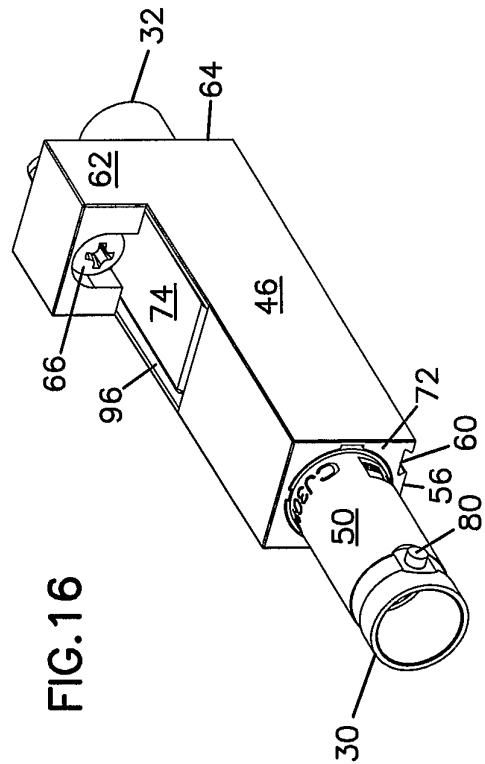

FIG. 16

FIG.19

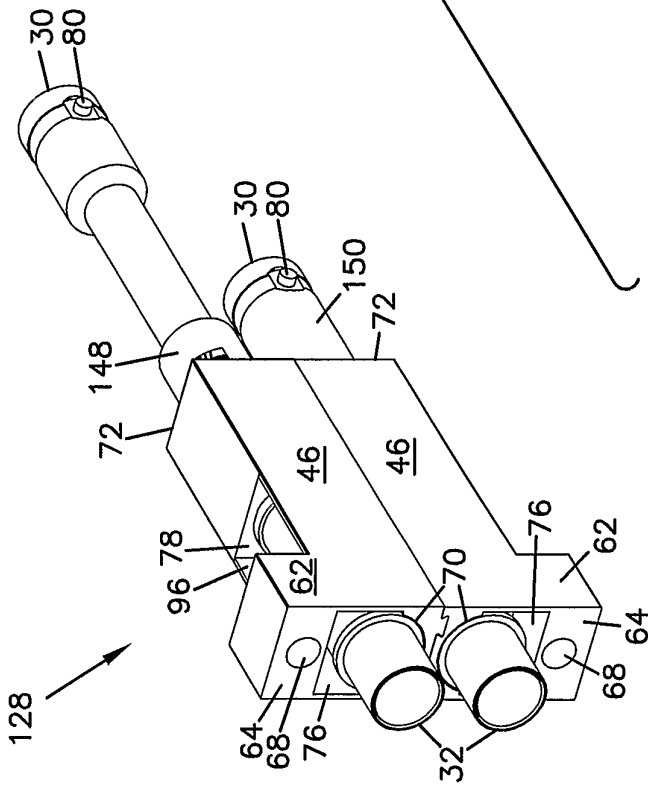
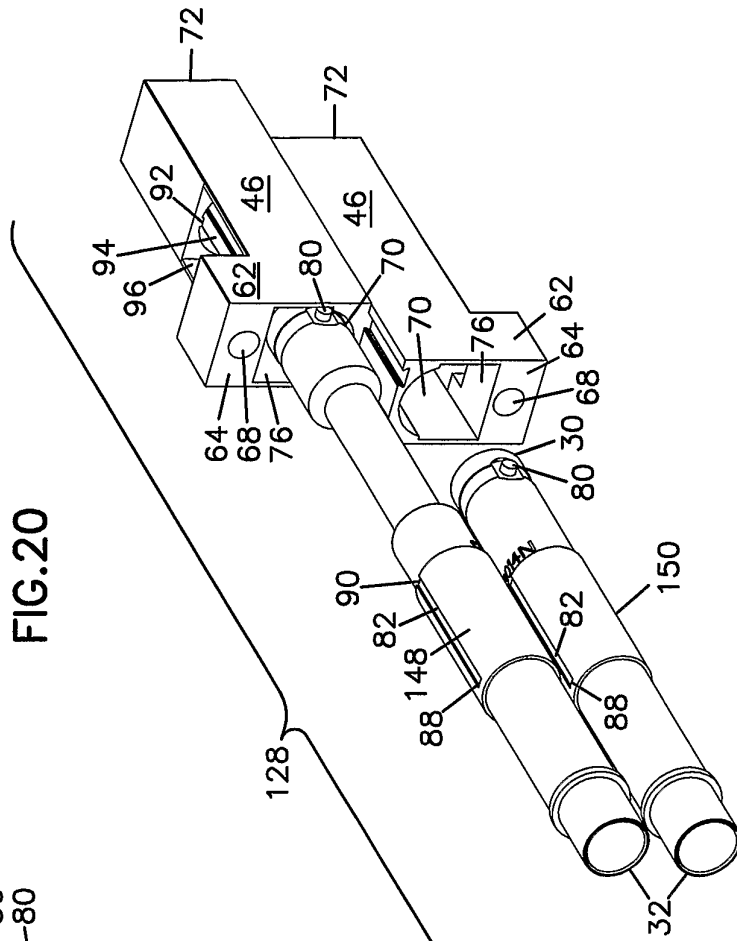

FIG.20



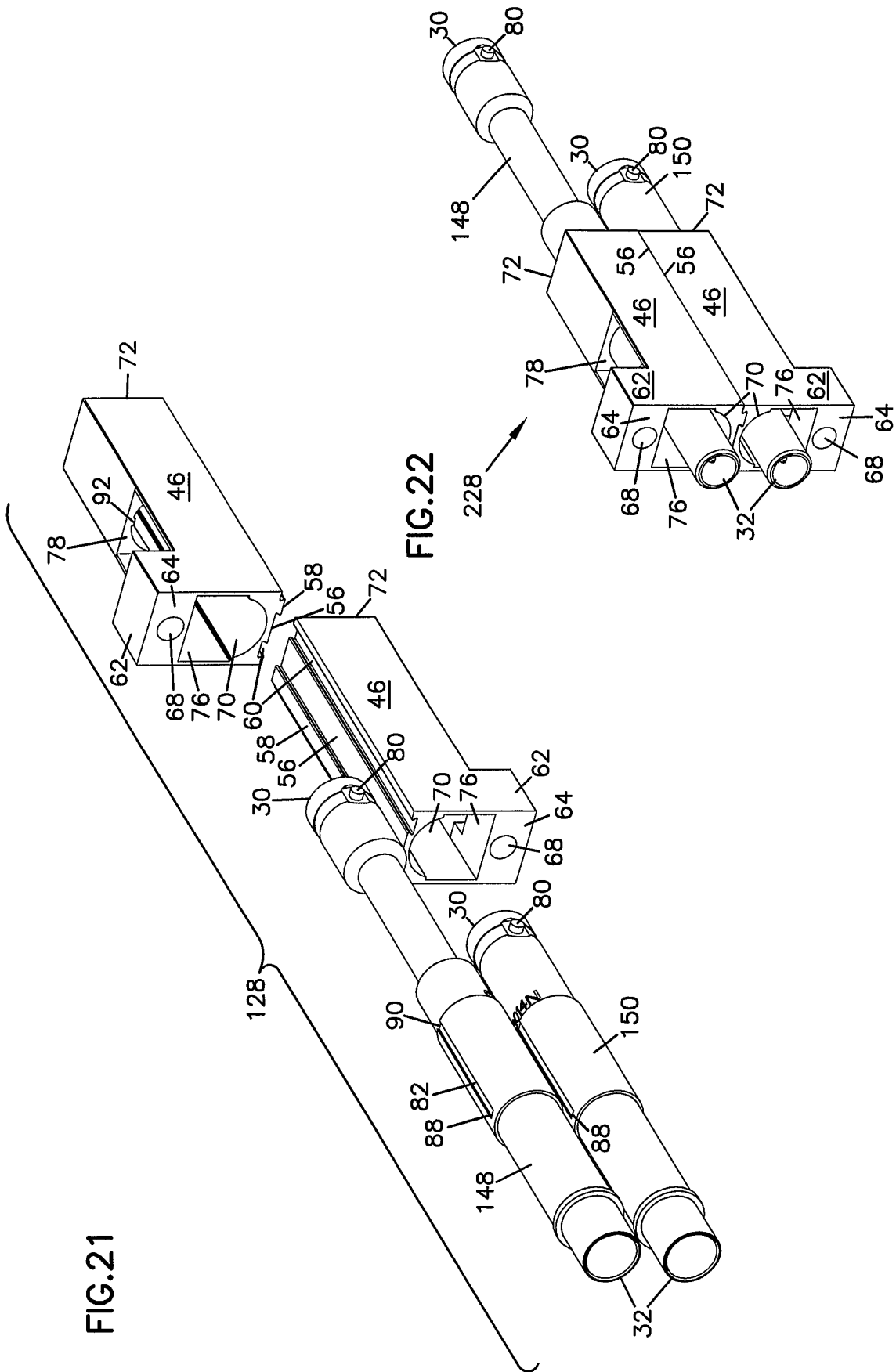
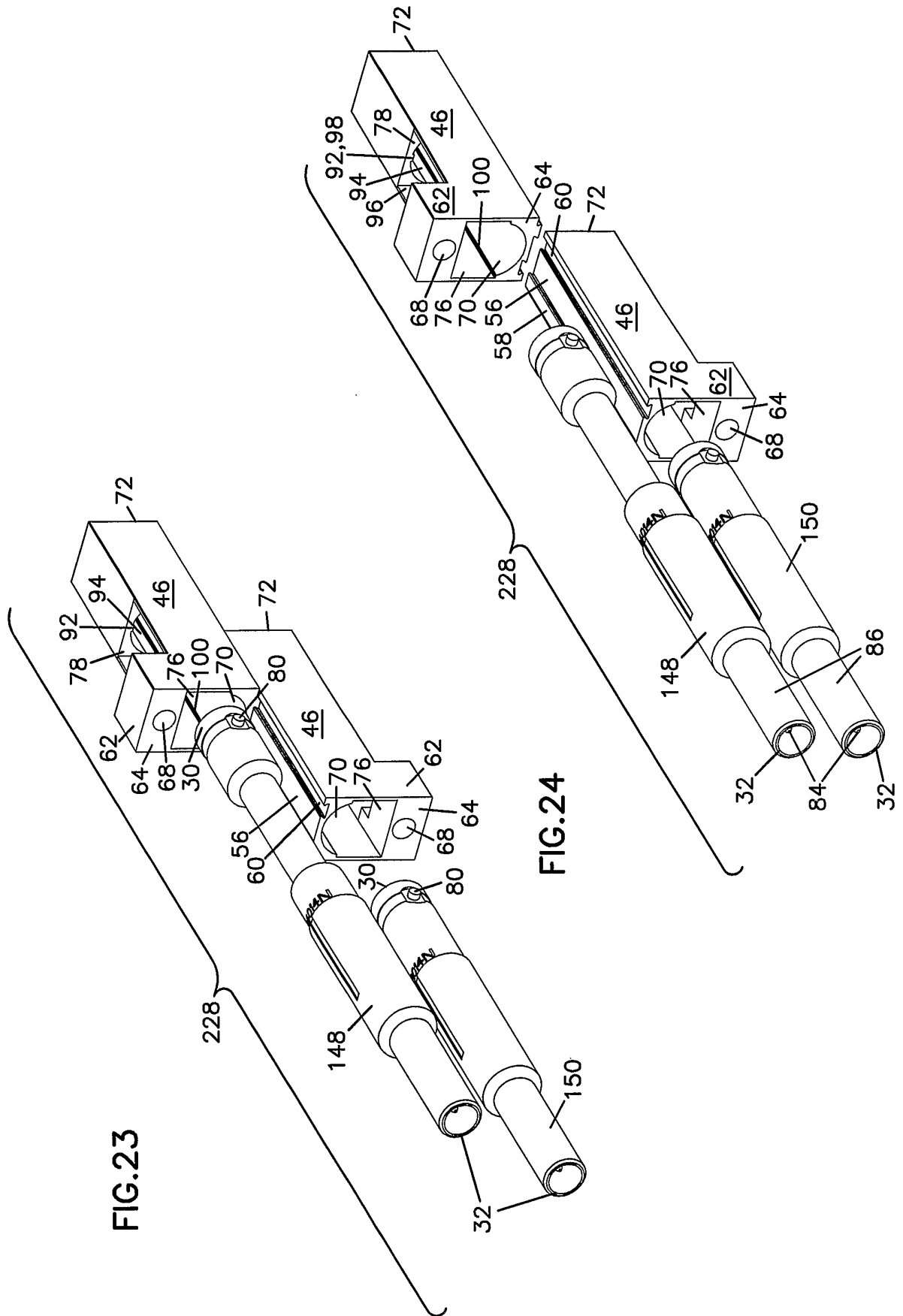

FIG. 21

FIG. 22



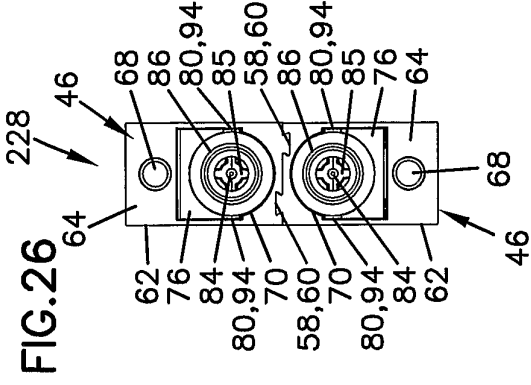

FIG. 26

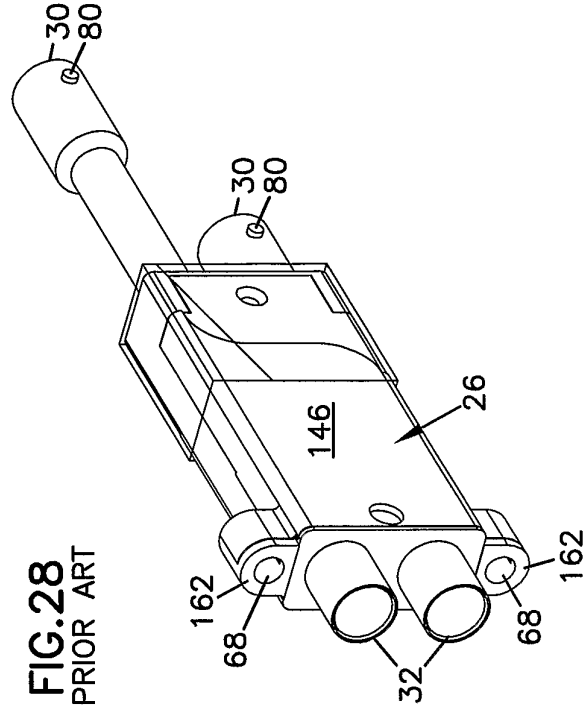

FIG. 28
PRIOR ART

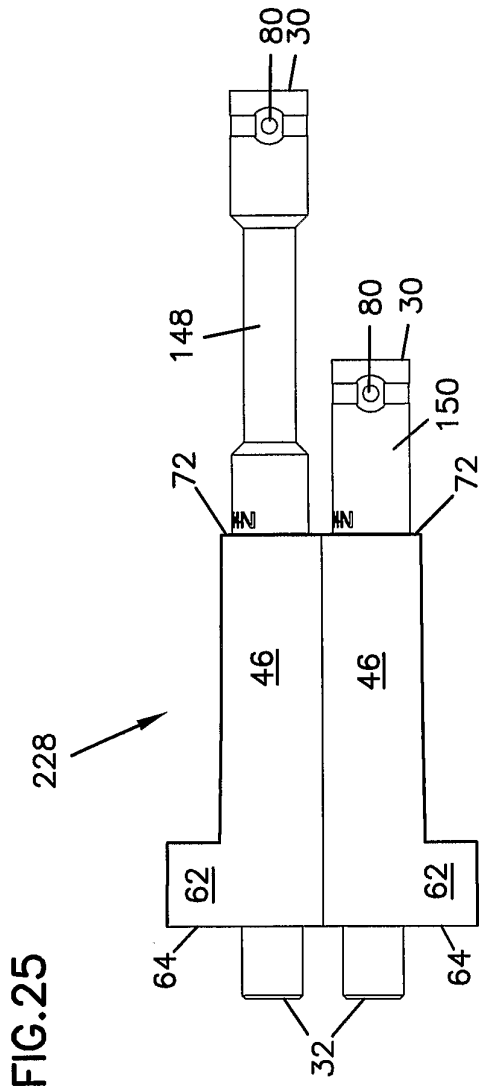

FIG. 25

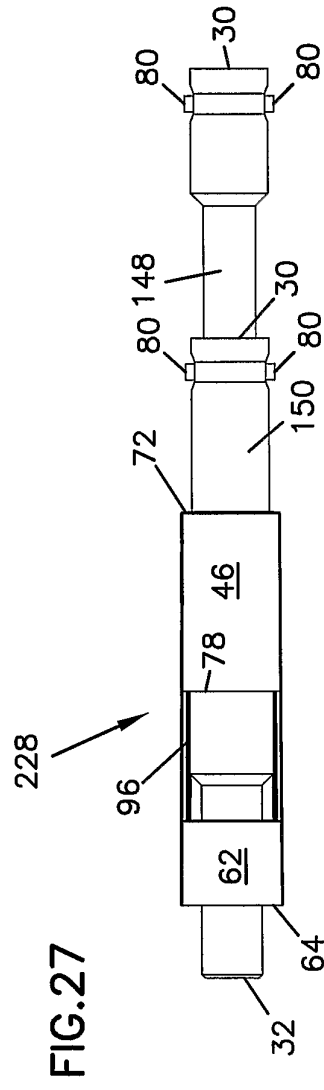

FIG. 27

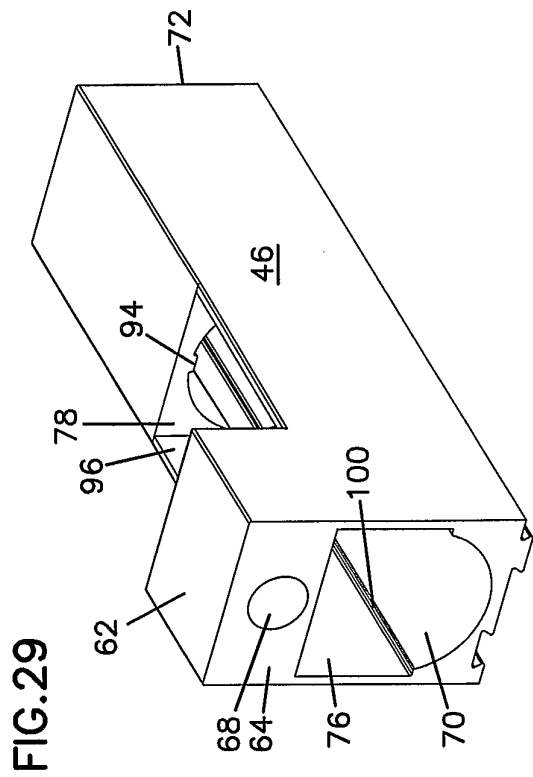

FIG. 29

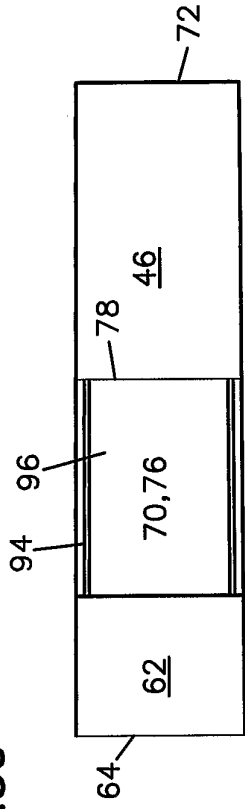

FIG. 30

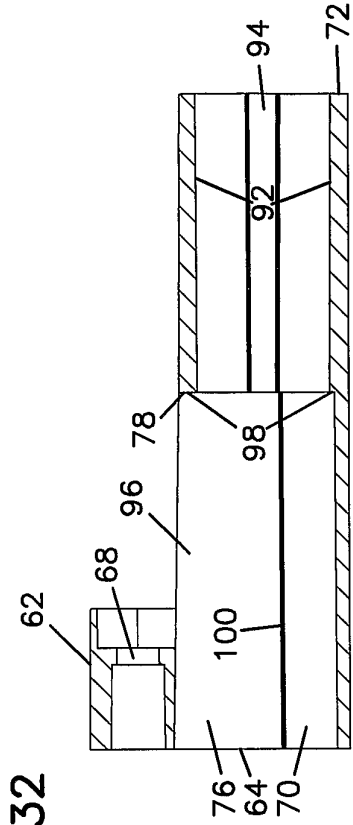

FIG. 32

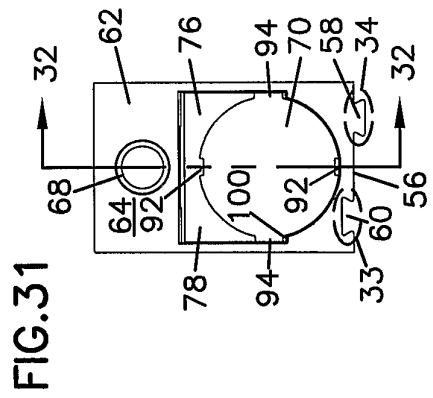

FIG. 31

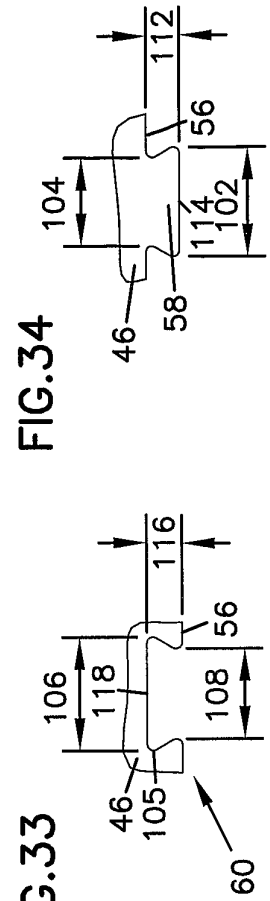

FIG. 33

FIG. 34

FIG.37

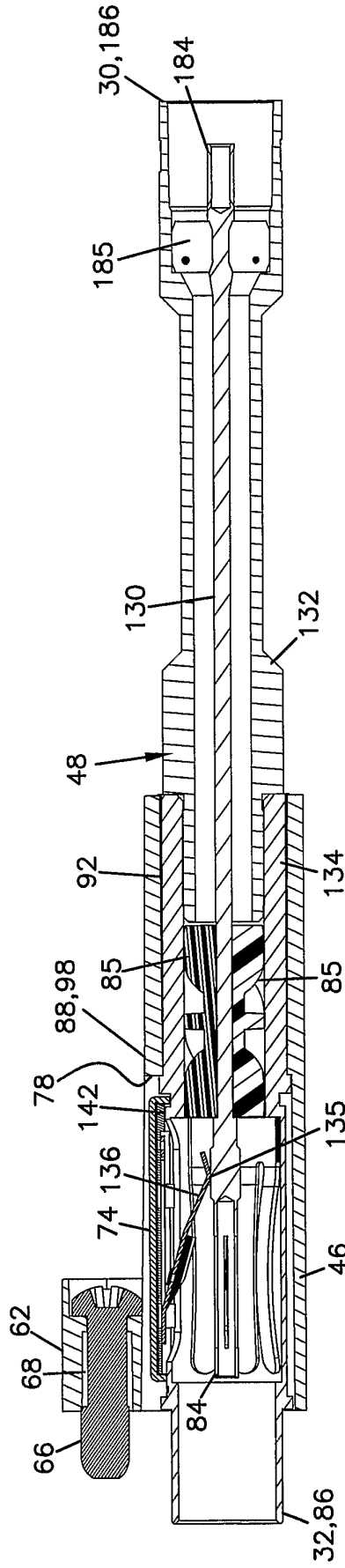

FIG.40

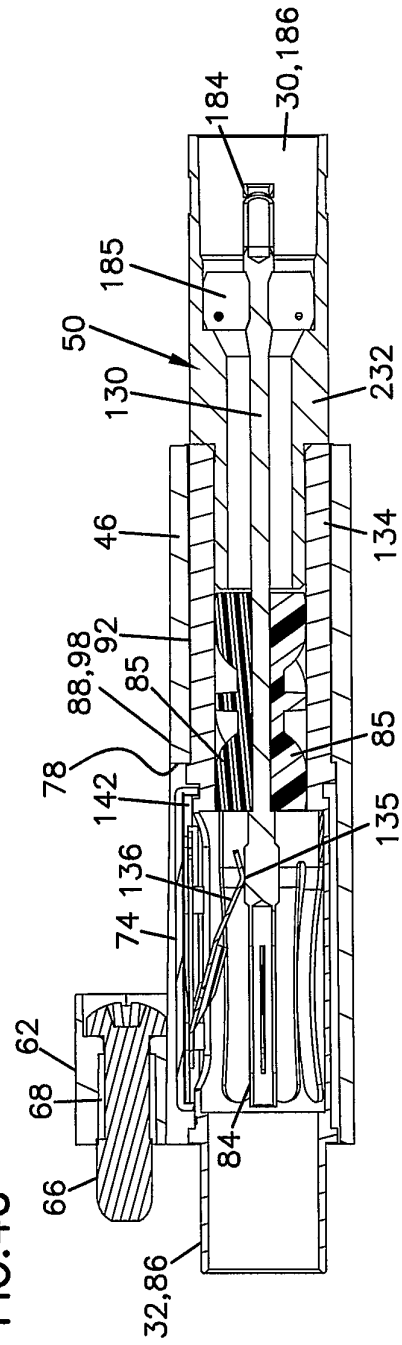

FIG. 38

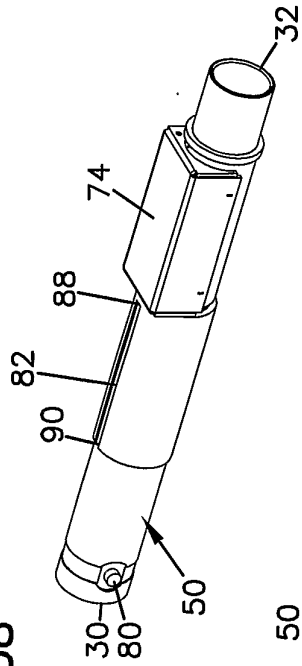

FIG. 39

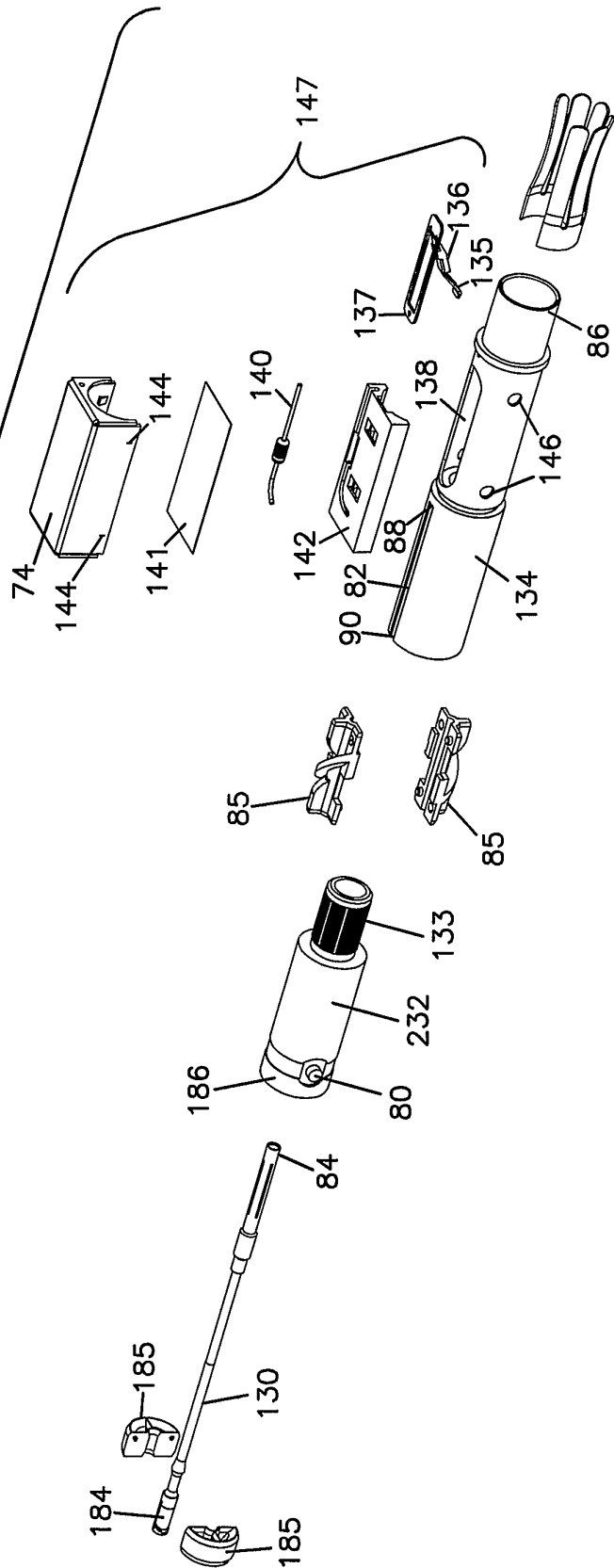

FIG. 41

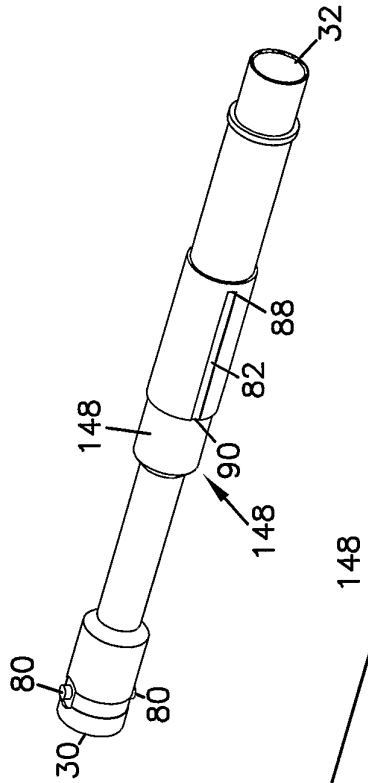

FIG. 42

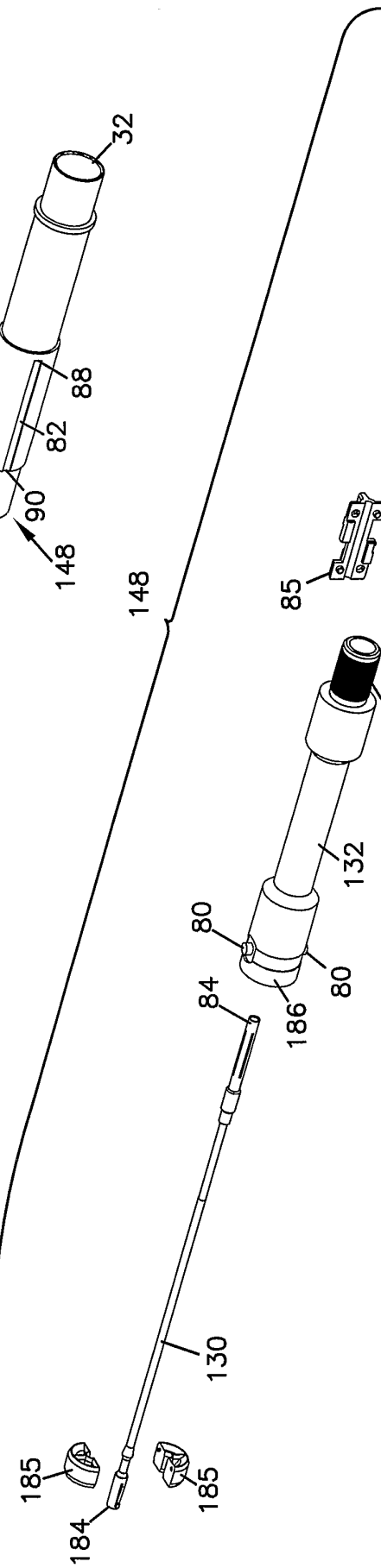

FIG. 43

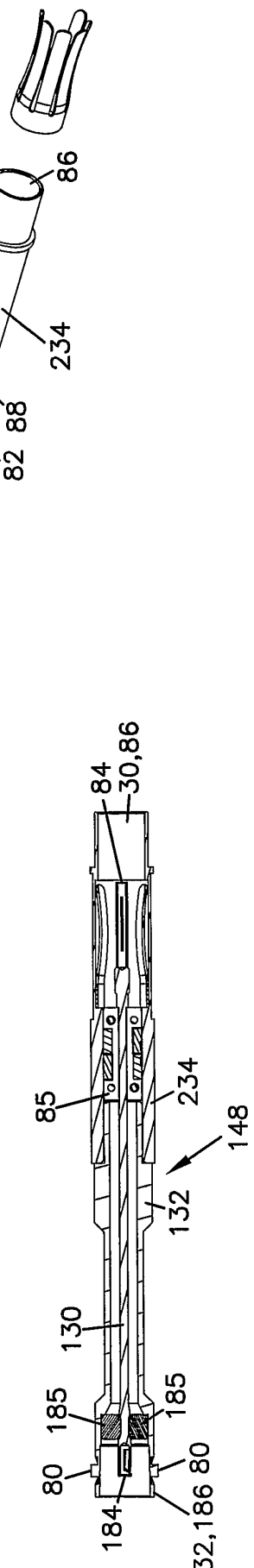

FIG. 44

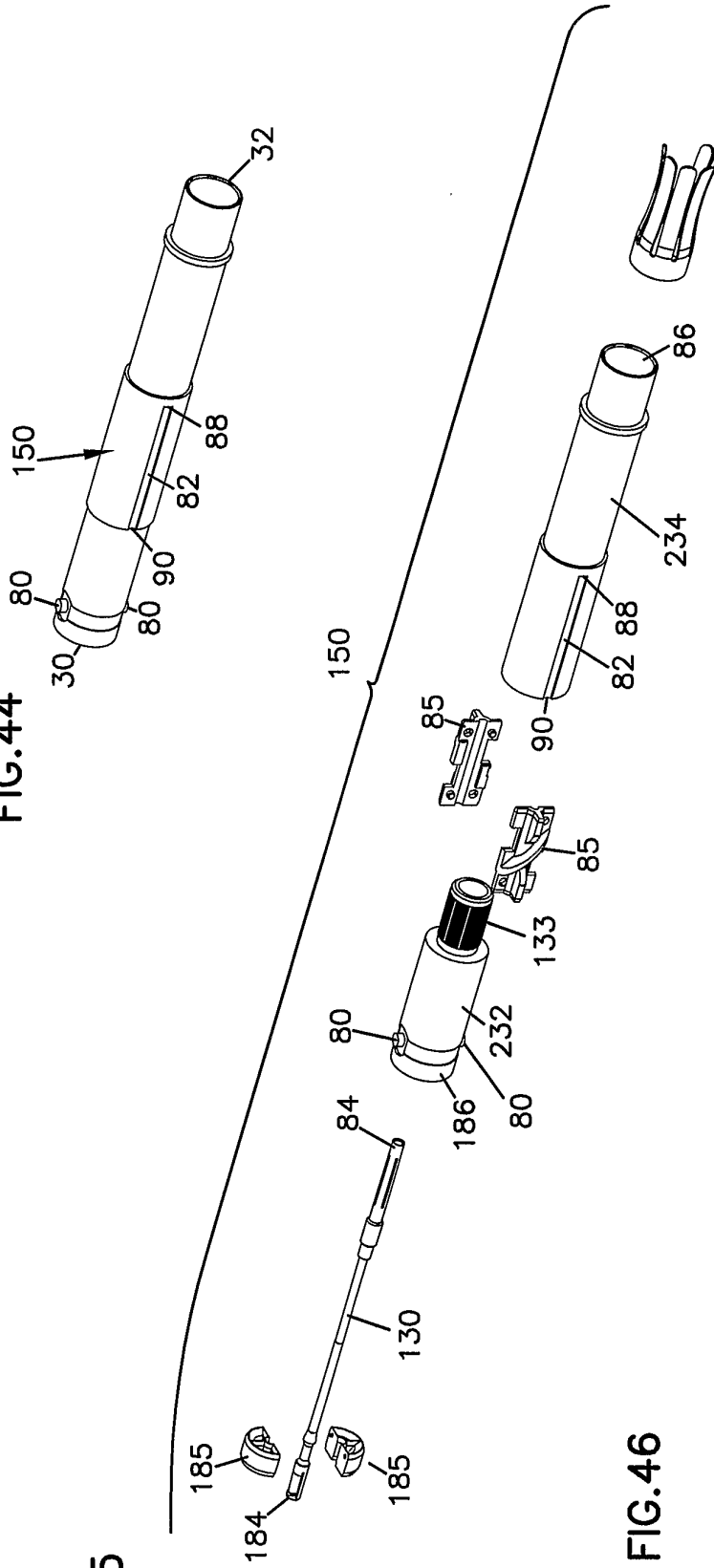

FIG. 45

FIG. 46

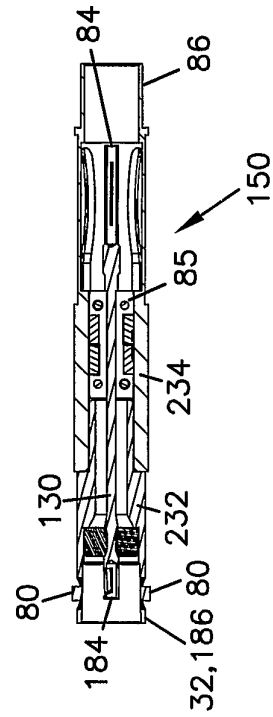

FIG. 47

