



US 20150087204A1

(19) **United States**  
(12) **Patent Application Publication**  
**Conde**

(10) **Pub. No.: US 2015/0087204 A1**  
(43) **Pub. Date: Mar. 26, 2015**

(54) **SHAPE SUPPORT SYSTEM FOR GARMENTS**

(52) **U.S. Cl.**

(71) Applicant: **Frances Conde**, Miramar, FL (US)

CPC ..... *A41C 3/12* (2013.01)

USPC ..... **450/93**

(72) Inventor: **Frances Conde**, Miramar, FL (US)

(57) **ABSTRACT**

(21) Appl. No.: **14/495,426**

(22) Filed: **Sep. 24, 2014**

**Related U.S. Application Data**

(60) Provisional application No. 61/960,718, filed on Sep. 24, 2013.

**Publication Classification**

(51) **Int. Cl.**  
*A41C 3/12* (2006.01)

The present disclosure provides a garment including a shape memory material, wherein upon the shape memory material reaching a transition temperature, the shape memory material transforms from a first shape to a second shape, wherein the second shape imparts a greater force to a body part with which the garment is in contact as compared to the force imparted to the body part by the first shape, wherein the transition temperature is between, and including, 90° F. and 105° F. The garments of the present disclosure may include bras, foundation garments, athletic/sports bras, swimwear, among others.

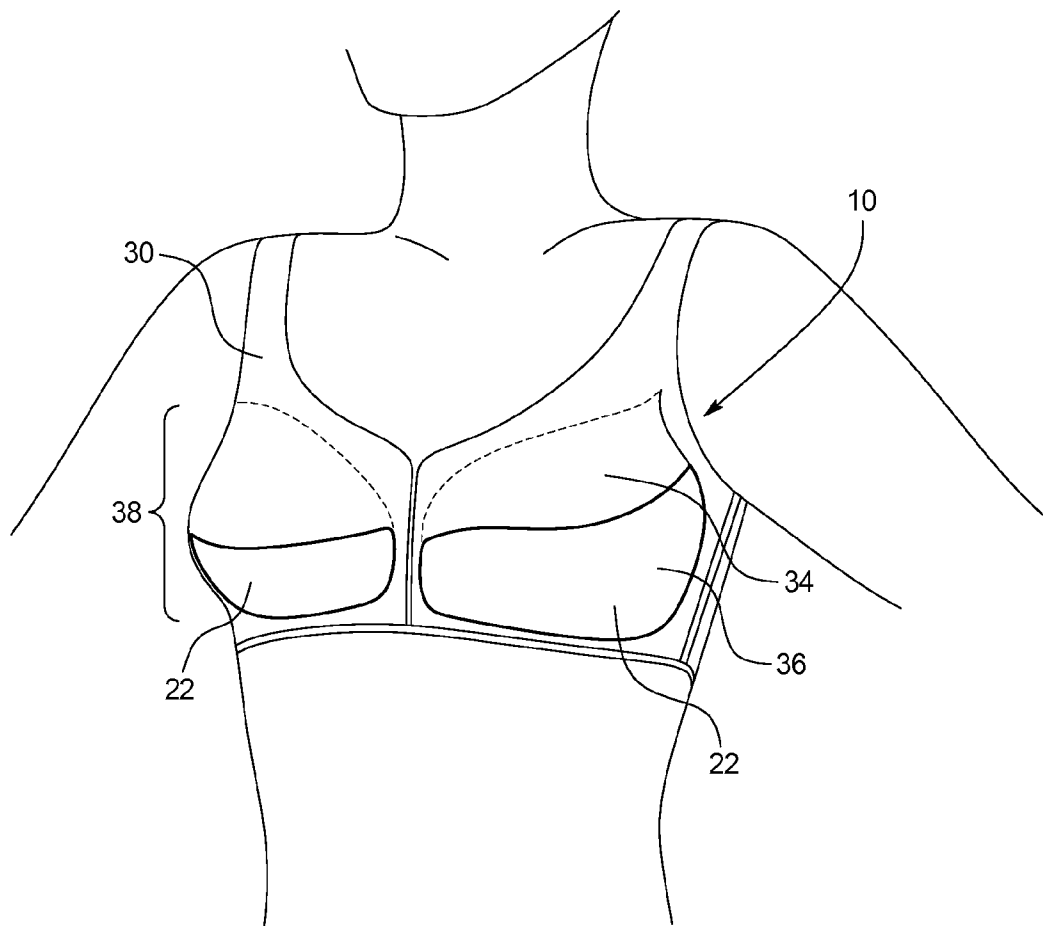

FIG. 1

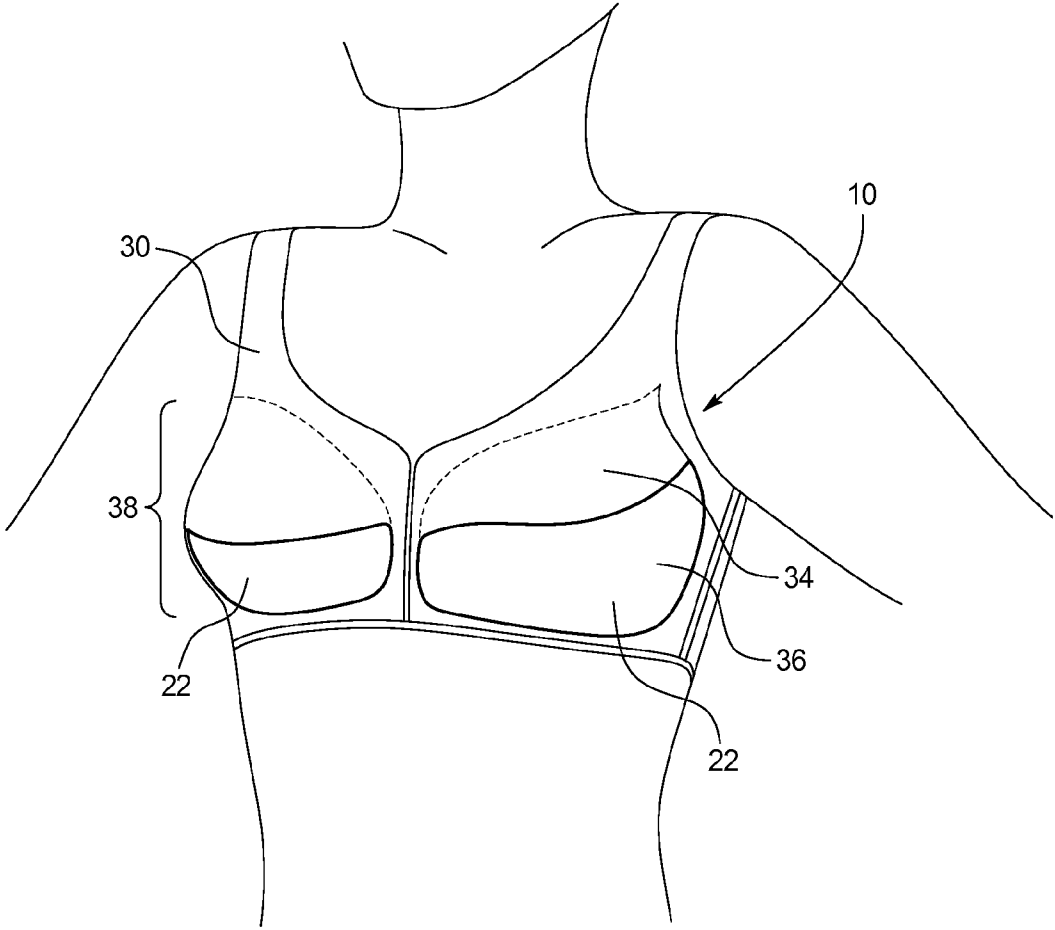

FIG. 2

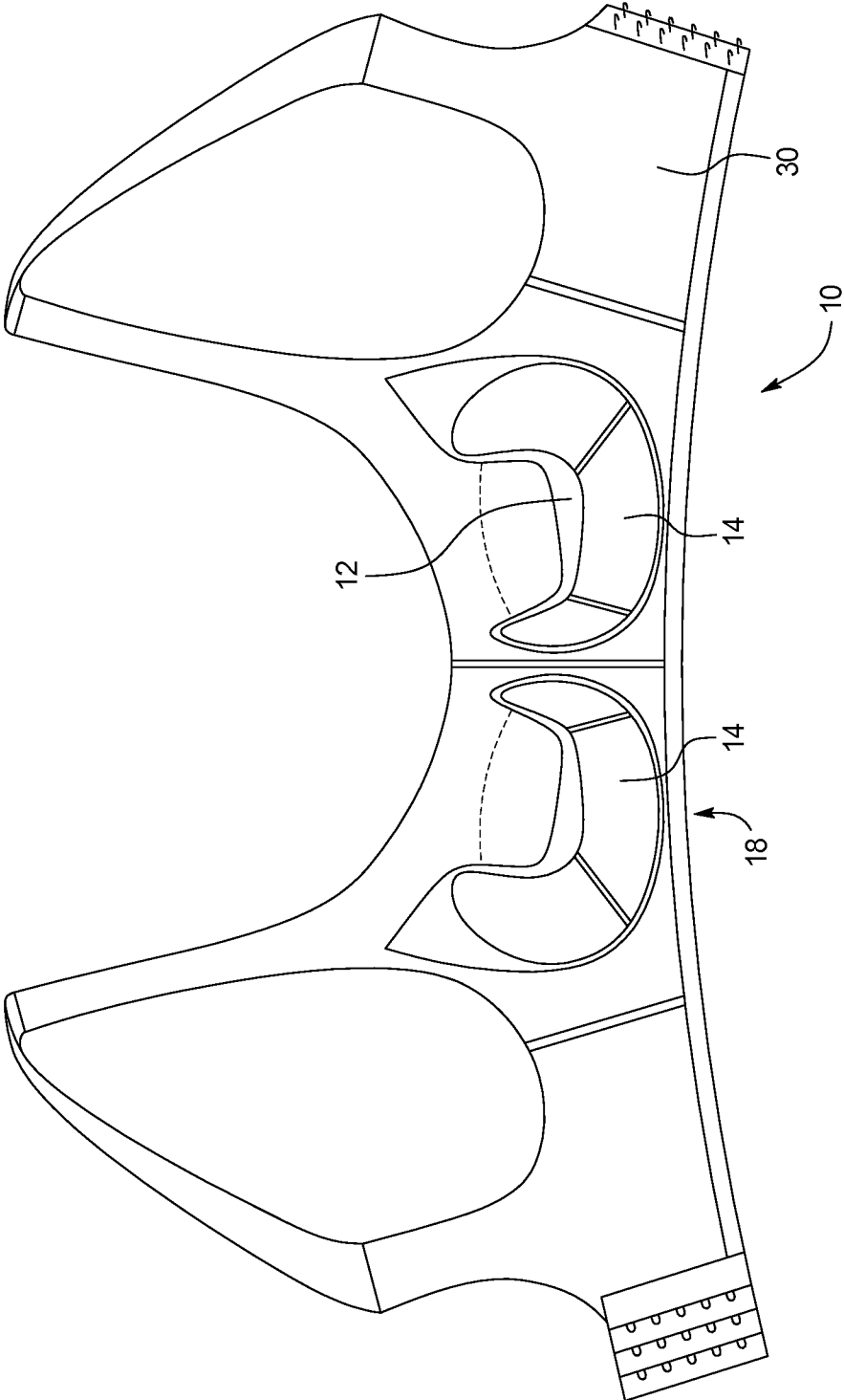

FIG. 3

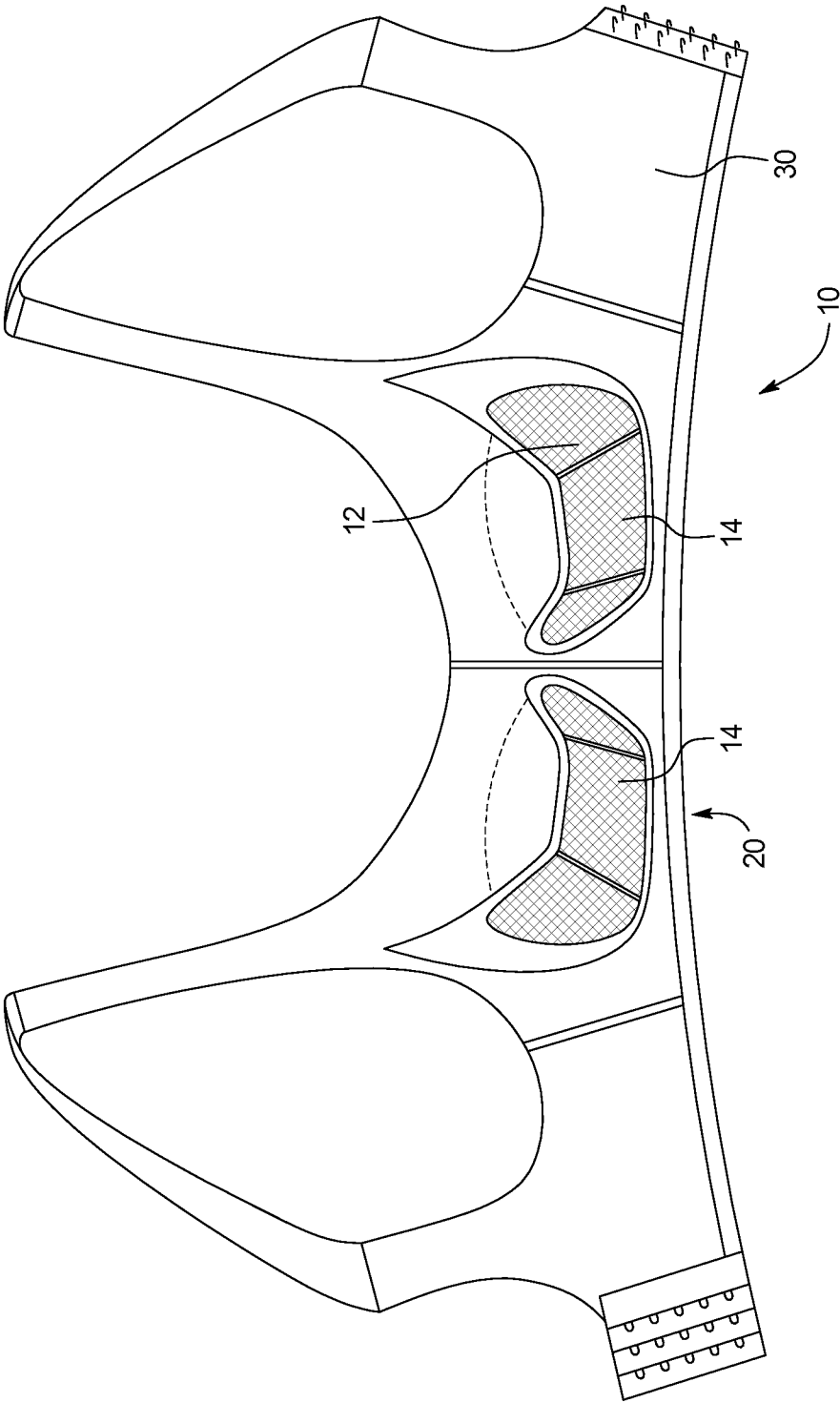

FIG. 4

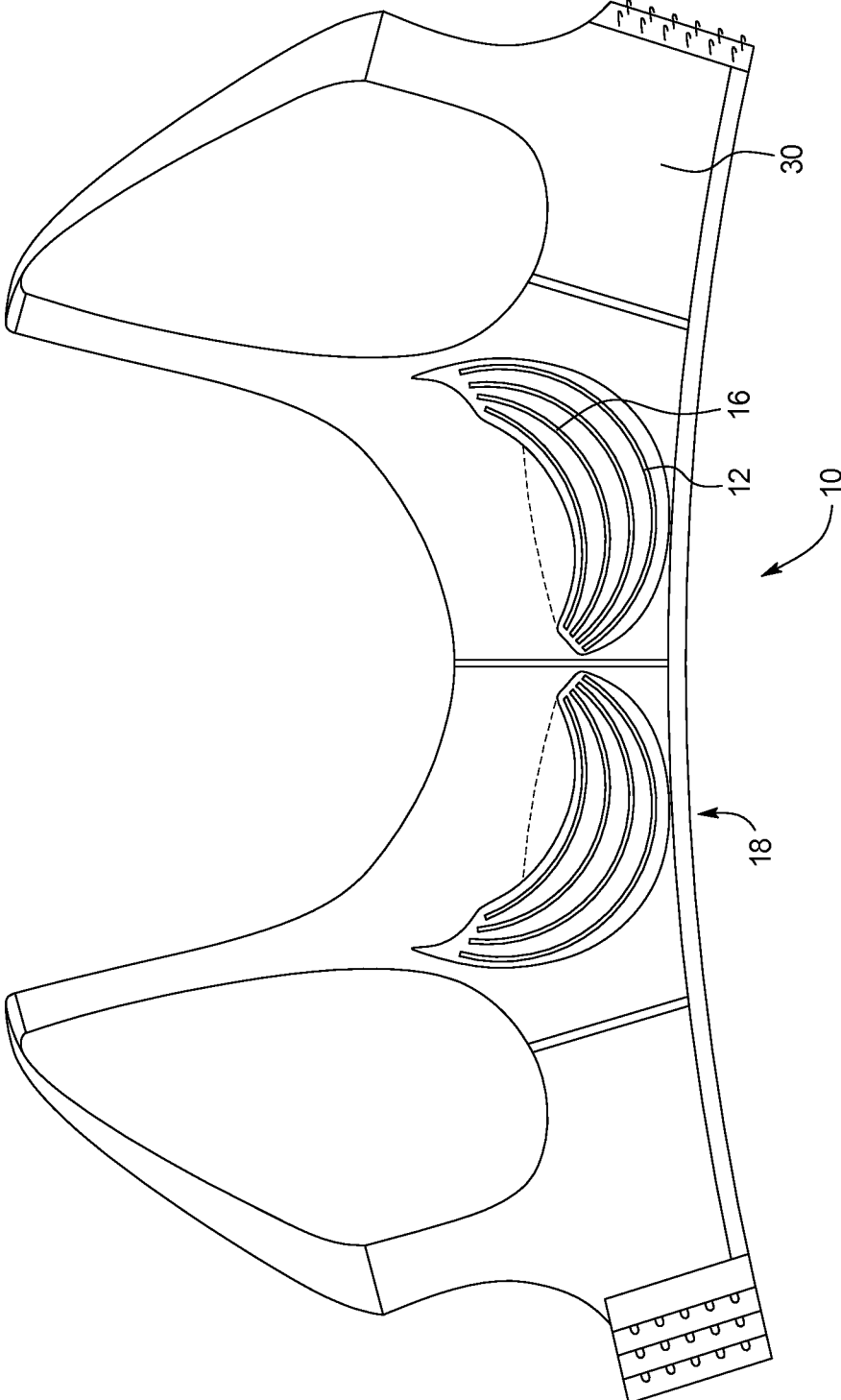

FIG. 5

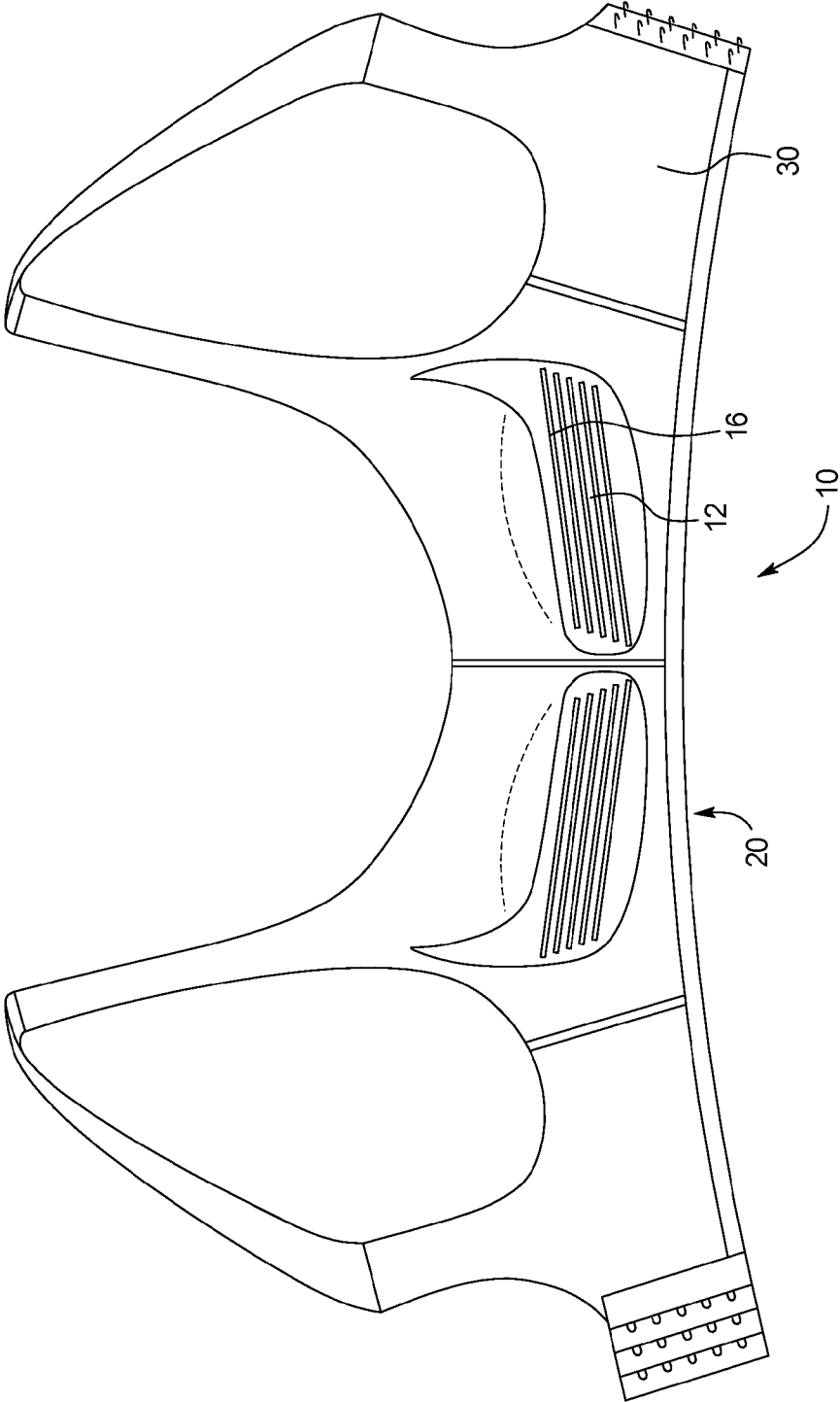

FIG. 6B

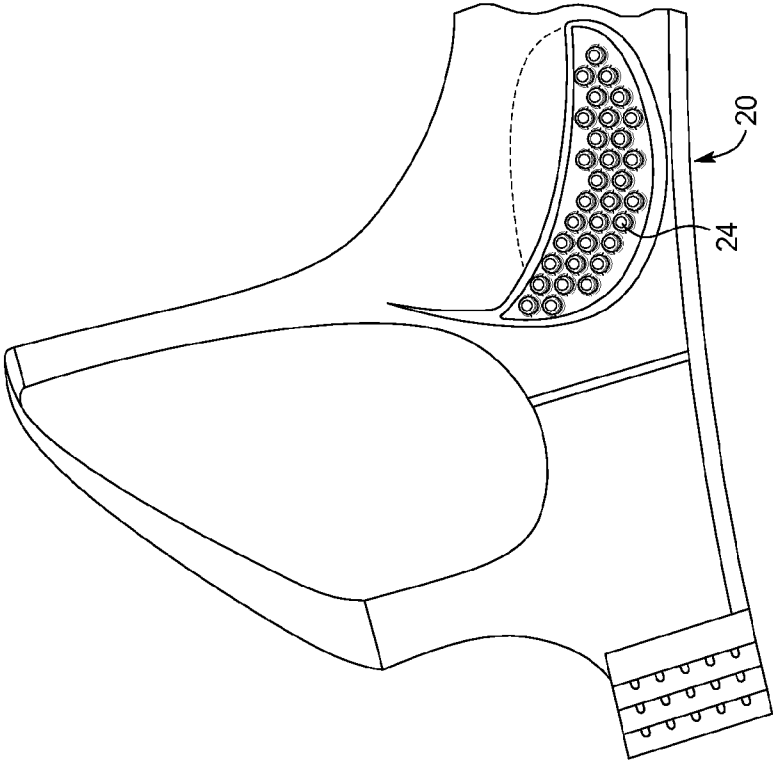

FIG. 6A

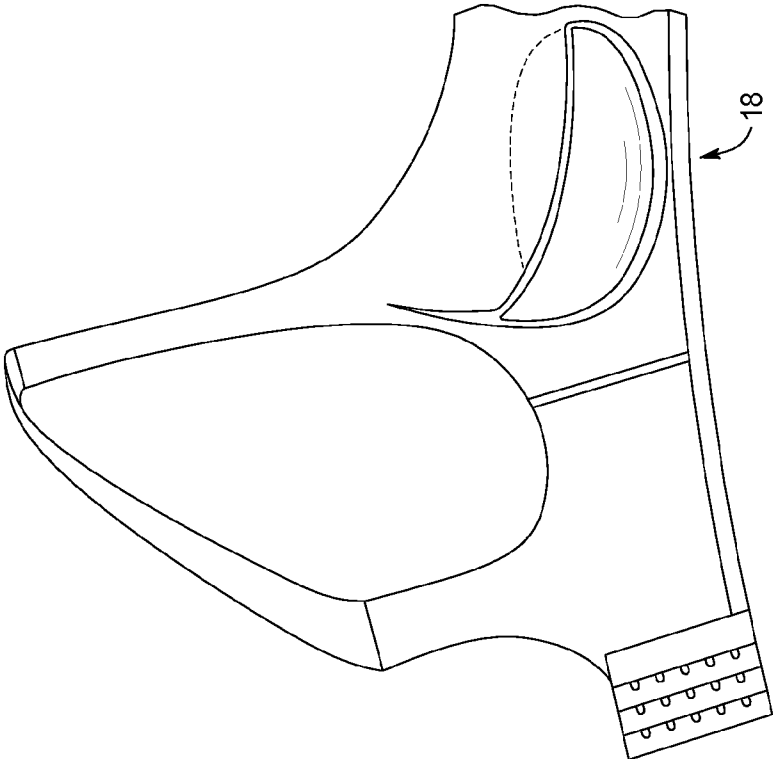

FIG. 7B

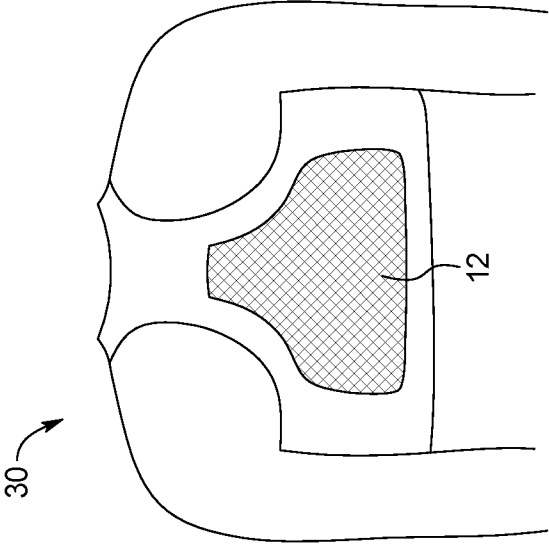
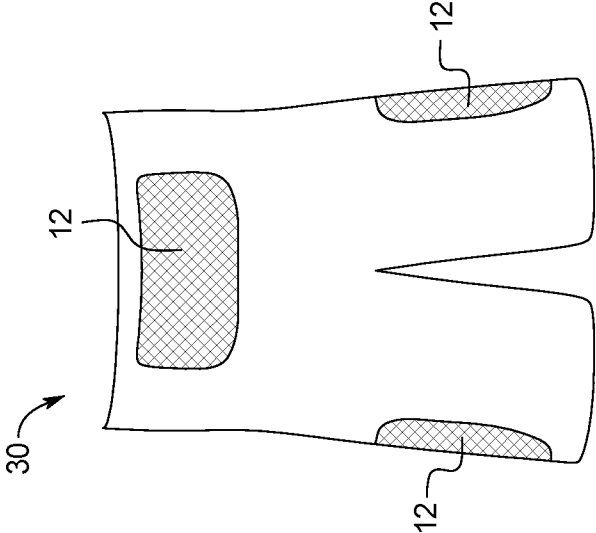
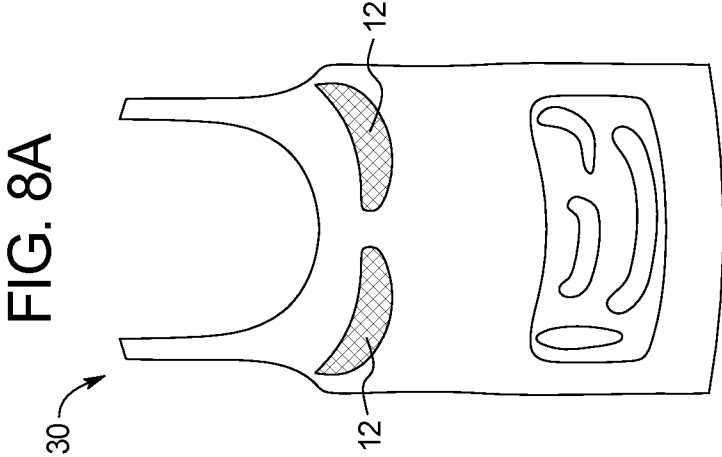
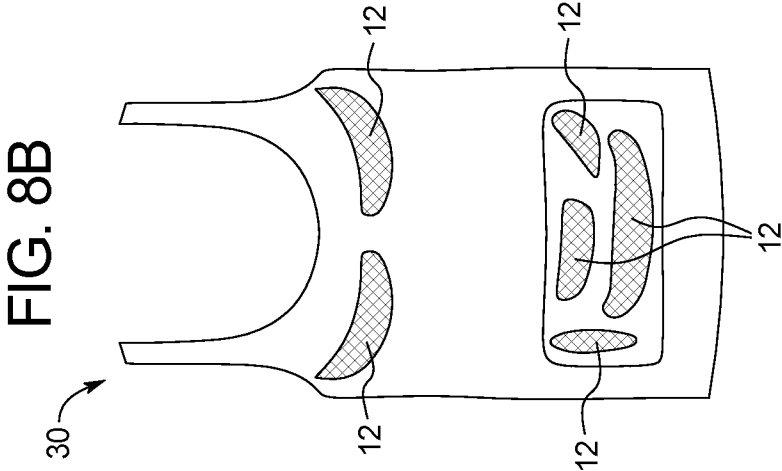

FIG. 7A







**SHAPE SUPPORT SYSTEM FOR GARMENTS**

**CROSS-REFERENCE TO RELATED APPLICATIONS**

[0001] This application incorporates by reference and claims the benefit of priority to U.S. Provisional Application 61/960,718 filed on Sep. 24, 2013.

**BACKGROUND OF THE INVENTION**

[0002] The present subject matter relates generally to shape support garments that use shape memory materials activated by body heat to provide targeted additional support. More specifically, in a primary embodiment, the present subject matter provides a bra including at least one bra cup portion that, in response to body heat, actively transitions from a traditional bra cup shape into a second shape that provides additional localized support in the form of compressive force applied into the breast.

[0003] Shapewear generally refers to undergarments designed to alter/control the wearer's body shape into a desired form. Typical materials used in shapewear include elastane, polyamide, latex, etc. These materials are used for to take advantage of their elasticity to provide a compressive effect. In other words, because these materials are elastic (i.e., springy and flexible), shapewear garments can be made to be tight fitting and restrictively hold the wearer's body into the desired shape. Common garments used as shapewear include bodysuits, brassieres, corsets, control underwear, etc.

[0004] One drawback with traditional shapewear is that the garments are intentionally made to be tight fitting, by providing over all compression to accomplish the shaping goal. However, this makes the garments difficult to put on. It can be a struggle to even get into the garment itself.

[0005] In the realm of shapewear bras, various structures and materials, including pads, foams, gels, plastics, elastic fabrics, among others, have been used to provide a controlled shape to the wearer's breasts. Metal and plastic underwires further help maintain a desired shape to the bra. In addition, in some instances, shape memory alloys and shape memory polymers have been used in an intermediate layer of a bra to help maintain a desired shape of the bra. As a result of the combination of stiff, rigid, and tight materials, on top of being uncomfortably tight to put on, athletic/sports and foundation bras may be even more uncomfortable to wear.

[0006] Specifically with respect to underwires, traditional underwires provide only limited support and are used to maintain the shape of the bra. The underwires are typically rigid and tend to "dig into" the body of the wearer, and as a result, may be very uncomfortable for a wearer. Often times, the underwire may break through the material of the bra and cause further irritation to the wearer and damage to the wearer's clothing. Further, the rigidity of conventional underwires do not accommodate for the discrepancies in body shapes. Underwires have also been associated with burns when a defibrillator is used on a wearer.

[0007] These materials and designs have left much room for improvement in the shapewear space. As a result, there is a need for garments that are easier to put on and provide localized and personalized support to the wearer's body.

**BRIEF SUMMARY OF THE INVENTION**

[0008] The present disclosure provides a garment including a body heat activated memory shape material based support

system that provides localized shape and support to specific areas of the body. For example, in contrast to conventional shapewear and support garments that merely attempt to maintain the shape of the garment and/or provide consistent overall compressive forces to the body, the present system is directed to a garment that is body heat activated to provide support, shape, and enhancement to a wearer's breasts, for example. Various examples of the systems are provided herein. In addition, notwithstanding the illustrated examples in the description of a garment to support the breasts of a wearer, the present subject matter may apply to any number of garments for providing shape and support to the body.

[0009] The present disclosure provides a support system that includes a shape memory material that may include a shape memory alloy (SMA), such as nitinol, and/or shape memory polymers (SMP) technology. The shape memory material may be biocompatible, biodegradable, and/or recyclable. The shape memory material includes shape memory properties to retain spring-like qualities, which aids in the lifting and supporting of breasts, as well as other targeted areas of the body. In addition, the shape memory material materials have the ability to restore from a deformed state back to the preformed shape when induced by an external stimulant, such as a specific temperature or pressure. For example, the stimulus may be the body temperature and/or pressure applied by the breast of the wearer. As a result, the shape memory material in the present system has a localized effect on a specific targeting area of the body.

[0010] The shape memory material of the present support system is designed to have a first shape that transitions to a second shape upon an activation temperature that is approximately the body temperature of the user. For example, the first shape may be concave and the second shape may be more planar. In such example, the support system may include a support panel in a lower half of a breast cup of a bra. The support panel may include the shape memory material such that support panel may transition between a first shape that is concave and a second shape that is more planar, wherein the transition is dependent on a transition temperature that is approximately the body temperature of a wearer. As such, when a wearer puts on the bra, the support panel transitions from a concave shape to a planar shape, which pushes or lifts the breast within the cup of the bra. In other words, once worn, the bra is heat activated to increase the pressure into selected portions of the breast within which it is in contact.

[0011] The shape memory materials may be used individually or in combination with other materials such as synthetic textiles, organic textiles, foam, pads, plastics, gels, silicone, among others. The shape memory materials may be included in several configuration such as simple or complex geometries in the form of a mesh, single wire, multiple wires, fibers, knitted fibers, mesostructures, or combinations thereof. Of course, other compatible materials may be included to aid in comfort, shape, or improved appearance of the wearer.

[0012] In an embodiment, the support system includes the shape memory materials in a casing, which is derived from fabric or other material. The casing may attach to the garment, such as a bra. Alternatively, or in addition to, the shape memory materials may be embodied as a panel or interface that is integrated within a garment. The support system is typically positioned on the lower half and outer part of a breast cup of a bra. In yet another example, the support system

may include a complex mesostructure geometry that conforms to the area of the body and transitions in specified locations.

**[0013]** The support system may also be incorporated into active wear, such as athletic sport bras, and into foundation garments, such as shapewear garments, for improved shape and support.

**[0014]** In an embodiment, the support system includes a garment including a shape memory material, wherein upon the shape memory material reaching a transition temperature, the shape memory material transforms from a first shape to a second shape, wherein the transition temperature is between, and including, 90° F. and 105° F. In an example, the shape memory material includes polyurethane.

**[0015]** The first shape may be concave and the second shape may be more planar/less concave. In another example, the first shape may be concave and the second shape may be convex. In yet another example the first shape includes a concave smooth surface and the second shape includes convex projections extending from the concave smooth surface.

**[0016]** In an embodiment, the system includes a brassiere including a pair of breast cups each including an upper portion and lower portion, wherein the lower portion includes a shape memory material, wherein upon the shape memory material reaching a transition temperature, the shape memory material transforms from a first shape to a second shape, wherein the second shape imparts a greater localized compressive force to a body part with which the garment is in contact as compared to the compressive force imparted to the body part by the first shape, wherein the transition temperature is between, and including, 90° F. and 105° F.

**[0017]** An advantage of the present system is providing localized support to areas of a body that a wearer feels they need more shape or support. As a result of the individualized interface, the system provides a comfortably support solution.

**[0018]** An advantage of the present system is providing a specific and targeted support within garments, unlike conventional compression garments that create a uniform compressive nature.

**[0019]** A further advantage of the present system is providing a garment that can transform shape based on the wearer's body temperature to provide support or shape change to a wearer's body in a customizable manner.

**[0020]** Yet another advantage of the present system is that it enables shapewear to be designed to fit in a looser configuration as it is being put on and then the warming of the shapewear by the person's body tightens the shapewear into a more supportive configuration.

**[0021]** Additional objects, advantages and novel features of the examples will be set forth in part in the description which follows, and in part will become apparent to those skilled in the art upon examination of the following description and the accompanying drawings or may be learned by production or operation of the examples. The objects and advantages of the concepts may be realized and attained by means of the methodologies, instrumentalities and combinations particularly pointed out in the appended claims.

#### BRIEF DESCRIPTION OF THE DRAWINGS

**[0022]** The drawing figures depict one or more implementations in accord with the present concepts, by way of example only, not by way of limitations. In the figures, like reference numerals refer to the same or similar elements.

**[0023]** FIG. 1 is a perspective view of an embodiment of the support system including a support panel that is connected to a lower half of a breast cup of a bra.

**[0024]** FIG. 2 is a perspective view of an example of a shape memory material in the form of a mesh in a first shape.

**[0025]** FIG. 3 is a perspective view of an example of a shape memory material in the form of a mesh in a second shape.

**[0026]** FIG. 4 is a perspective view of an example of a shape memory material in the form of a plurality of wires in a first shape.

**[0027]** FIG. 5 is a perspective view of an example of a shape memory material in the form of a plurality of wires in a second shape.

**[0028]** FIG. 6A is a perspective view on an example of a shape memory material in a first shape.

**[0029]** FIG. 6B is a perspective view on an example of a shape memory material in a second shape.

**[0030]** FIG. 7A-7B are front views of systems including various garments including the shape memory material.

**[0031]** FIG. 8A-8B are front views of systems including a garment including the shape memory material in a plurality of sections.

#### DETAILED DESCRIPTION OF THE INVENTION

**[0032]** The present support system **10** includes a shape memory material **12** for use in garments **30**. The garment **30** may be any suitable garment. For example, the garment **30** may be a brassieres (bra), including athletic/sports bras, lingerie, specialty bras for mastectomy or body impairments. The garment **30** may also be any of foundation garments, underwear, camisoles, shirts, pants, socks, swim wear, hats, among other clothing and accessories. The garment **30** may be any garment **30** in which it is desirable to start in a first configuration/shape and transition to a second more constraining or supportive position after the application of body heat.

**[0033]** The shape memory material **12** may be attached to already existing garments **30**, or maybe be integrally formed with a garment **30**. For example, the support system **10** may include shape memory material **12** in the form of a support panel **22** that may be an insert or attachment to a cup of a bra, as shown in FIGS. 1-5. However, it is contemplated that the support panel **22** may be integrated within any number of garments to provide support and shape in the areas of the abdomen, torso, thighs, buttocks, back, legs, and combinations thereof.

**[0034]** As shown in FIGS. 1-5, the shape memory material **12** forms a surface that may extend over a lower half of a bra cup. Alternatively, the shape memory material **12** may for a surface that extends over the entirety of each bra cup. Of course it is contemplated that the shape memory material **12** may extend over any proportion of the surface of a bra including a bra cup, the body of the bra, and/or straps of the bra. For example, the shape memory material **12** may extend over a percentage of the surface of a bra cup including, but not limited to, 40%, 50%, 60%, 70%, or 80%.

**[0035]** The shape memory material **12** may be a shape memory alloy (SMA), which is also referred to as a smart metal, memory metal, memory alloy, or smart alloy. The SMA remembers its original shape and that when deformed returns to its pre-deformed shape when the material is heated. The SMA may be a copper-aluminum-nickel alloy and/or nickel-titanium (NiTi) alloy. Of course, the SMA may include any suitable alloy including zinc, copper, gold, and iron.

**[0036]** Alternatively, or in addition to, the shape memory material **12** maybe a shape memory polymer (SMP). SMP materials are polymeric smart materials that have the ability to return from a deformed state to their pre-deformed shape included by an external stimulus, such as temperature change. In addition to temperature change, the shape change of the SMP may be triggered by electric or magnetic field, light, pressure, chemical, or solution. The SMP may include thermoplastic and thermoset, including covalently cross-linked, polymeric materials. For example, the SMP may include polyethers, polyacrylates, polyamides, polysiloxanes, polyether amides, polyvinyl ethers, polyether esters, urethane/butadiene copolymers, polyurethanes, polyethylene terephthalate, polyethyleneoxide, styrenebutadiene polymers, norbornane polymers, block copolymers of polystyrene and poly(1,4-butadiene, a copolymer of poly(2-methyl-2-oxazoline) and polytetrahydrofuran, polynorbornene, polyethylene/nylon-6 copolymer, styrene-1,4-butadiene block copolymer, ethylene oxide-ethylene terephthalate block copolymer, poly(methylene-1,3-cyclopentane) polyethylene block copolymer, or combinations thereof.

**[0037]** The shape memory material **12** may be in any suitable form, including, but not limited to, a solid support as shown in FIG. 1, a mesh support **14** (FIGS. 2-3), and a wire support **16** (FIGS. 4-5). In addition, the shape memory material **12** may be provided in different configurations including, but not limited to, fabrics, fibers, filaments, shape memory textiles, strips, gels, microbeads, and simple or complex geometries, such as mesostructures. The support panel **22** may be formed by machining, spinning, molding, extruding, or additive manufacturing.

**[0038]** The support system **10** may be integral within the cup of a bra. For example, the support system **10** may replace or be in addition to an intermediate foam layer within a bra. The shape memory material **12** may be incorporated or attached to breast cups **38** of a garment **30**. For example, the breast cups **38** may include an upper portion **34** and a lower portion **36**. In an example, the shape memory material **12** may be included in the lower portion **36**. For example, the support system **10** may include a support panel **22** including the shape memory material **12** that is positioned on or in the lower portion **36** of the breast cup **38**.

**[0039]** The support system **10** includes a shape memory material **12** that transforms from a first shape **18** to a second shape **20**. As shown in FIGS. 2-3 and 4-5, the shape memory material **12** may change from a first shape **18** that is concave to a second shape **20** that is more planar, upon the shape memory material **12** being approximately the shape of the body temperature of the user. In the case of the garment **30** being a bra, the transformation from the first shape **18** to a second shape **20** may result in lifting and pushing the breast of a wearer upward. In another example, the first shape **18** may be concave and the second shape **20** may be convex in order to lift up the breast of the wearer. The shape memory material **12** may be one continuous piece of material that in the first shape **18** is concave. Alternatively, the shape memory material **12** may be included in consecutive sections, as shown in FIGS. 2-3. For example, the breast cup may include three different panels of shape memory material **12**, wherein each panel includes a concave first shape **18** and a generally planar second shape **20**.

**[0040]** In yet another example, the shape memory material **12** may transform/transition from a first shape **18** that includes a smooth surface to a second shape **20** in which a

plurality of projections rise from the previously smooth surface, as shown in FIGS. 6A-6B. For example, the projections may be convex projections extending from the previously smooth surface. In such example, the shape memory material **12** may be used in a garment **30**, such as a bra or girdle. In the case of a bra, the first shape **18** may include a concave smooth surface and the second shape **20** may include convex projections **24** from the concave surface, which results in compressing/supporting the portion of the breast in contact with the projections **24**, which lifts up the breast of the wearer.

**[0041]** In another example, the shape memory material **12** may be incorporated into other garments, such as a foundation garment. As the shape memory material **12** reaches the transition temperature equivalent to the wearer's body temperature, the shape memory material **12** may transform from a first shape **18** that is smooth to a second shape **20** that increases the supporting force of the garment against the user's body. The increased supporting force may be provided, for example, by a plurality of projections that rise from the previously smooth surface. As such, the projections provide the desired localized support. Because the pressure garment includes the shape memory material **12** that transforms from a first shape **18** to a second shape **20**, the garment does not suffer the disadvantage of most conventional garments that loosen after wearing several times or after several washes. Nor is it as difficult to put on as traditional shapewear may be.

**[0042]** As shown in FIG. 7A, the system may include a garment **30** embodied in foundation garments that includes shape memory material **12** at the abdomen and thigh areas. As shown in FIG. 7B, the system may include a garment **30** embodied in a sports bra including the shape memory material **12** in the back of the sports bra.

**[0043]** FIG. 8A depicts a garment **30** embodied in a tank top wherein the shape memory material **12** is included in the chest area, such as in a built in bra, and the abdomen area. As shown, the abdomen area may include a plurality of shape memory material **12** sections wherein the first shape **18** may be curved (as shown in FIG. 8A) and the second shape **20** may be more planar/less curved (as shown in FIG. 8B).

**[0044]** The transition temperature for the shape memory material **12** to transform from a first shape **18** to a second shape **20** may be in the range of 70° F. to 120° F., for example, 80° F. to 110° F., 90° F. to 105° F., 95° F. to 100° F., or any combination thereof. The transition temperature may be the body temperature of the wearer of the garment. In another example, the transition temperature may be achieved by an external heat source such as a heated dryer, such as a clothes dryer or hair dryer.

**[0045]** It should be noted that various changes and modifications to the embodiments described herein will be apparent to those skilled in the art. Such changes and modifications may be made without departing from the spirit and scope of the present invention and without diminishing its attendant advantages. For example, various embodiments of the method and portable electronic device may be provided based on various combinations of the features and functions from the subject matter provided herein.

We claim:

1. A garment comprising:

a shape memory material, wherein upon the shape memory material reaching a transition temperature, the shape memory material transforms from a first shape to a second shape,

- wherein the second shape imparts a greater localized supportive force to a body part with which the garment is in contact as compared to the force imparted to the body part by the first shape,  
wherein the transition temperature is between, and including, 90° F. and 105° F.
2. The garment of claim 1 wherein the shape memory material includes polyurethane.
3. The garment of claim 1 wherein the first shape is concave and the second shape is less concave.
4. The garment of claim 1 wherein the first shape includes a smooth surface and the second shape includes projections extending from the previously smooth surface.
5. A brassiere comprising:  
a pair of breast cups each including an upper portion and lower portion, wherein the lower portion includes a shape memory material,

- wherein upon the shape memory material reaching a transition temperature, the shape memory material transforms from a first shape to a second shape,  
wherein the second shape imparts a greater localized supportive force to a body part with which the garment is in contact as compared to the force imparted to the body part by the first shape,  
wherein the transition temperature is between, and including, 90° F. and 105° F.
6. The brassiere of claim 5 wherein the shape memory material includes polyurethane.
7. The brassiere of claim 5 wherein the first shape is concave and the second shape is less concave.
8. The brassiere of claim 5 wherein the first shape includes a smooth surface and the second shape includes projections extending from the previously smooth surface.

\* \* \* \* \*