



(11) **EP 3 127 624 B1**

(12) **EUROPEAN PATENT SPECIFICATION**

(45) Date of publication and mention of the grant of the patent:
30.11.2022 Bulletin 2022/48

(21) Application number: **1572740.5**

(22) Date of filing: **30.03.2015**

(51) International Patent Classification (IPC):
B21D 5/01 (2006.01)

(52) Cooperative Patent Classification (CPC):
B21D 5/015

(86) International application number:
PCT/JP2015/059833

(87) International publication number:
WO 2015/152107 (08.10.2015 Gazette 2015/40)

(54) **BENDING-PRESS FORMING TOOL**

BIEGEPRESS FORMWERKZEUG

OUTIL DE FORMATION PAR PLIAGE-PRESSE

(84) Designated Contracting States:
AL AT BE BG CH CY CZ DE DK EE ES FI FR GB GR HR HU IE IS IT LI LT LU LV MC MK MT NL NO PL PT RO RS SE SI SK SM TR

(30) Priority: **31.03.2014 JP 2014072523**
09.03.2015 JP 2015046163

(43) Date of publication of application:
08.02.2017 Bulletin 2017/06

(73) Proprietor: **JFE Steel Corporation**
Tokyo, 100-0011 (JP)

(72) Inventors:
• **HORIE Masayuki**
Tokyo 100-0011 (JP)
• **YASUHARA Isamu**
Tokyo 100-0011 (JP)

• **TAMURA Yukuya**
Tokyo 100-0011 (JP)
• **TANIICHI Kenji**
Akashi-shi
Hyogo 674-0093 (JP)

(74) Representative: **Grünecker Patent- und Rechtsanwälte**
PartG mbB
Leopoldstraße 4
80802 München (DE)

(56) References cited:
DE-A1- 19 504 736 DE-A1- 19 504 736
JP-A- S5 650 722 JP-A- S59 209 425
JP-A- 2004 082 219 JP-A- 2004 261 845
JP-A- 2005 324 255 JP-A- 2008 246 533
JP-A- 2012 250 285

EP 3 127 624 B1

Note: Within nine months of the publication of the mention of the grant of the European patent in the European Patent Bulletin, any person may give notice to the European Patent Office of opposition to that patent, in accordance with the Implementing Regulations. Notice of opposition shall not be deemed to have been filed until the opposition fee has been paid. (Art. 99(1) European Patent Convention).

Description

TECHNICAL FIELD

5 **[0001]** The present invention relates to a bending-press forming tool which is suitable for efficiently producing a thick steel pipe of a large diameter, for example, used for a line pipe or the like, by successively pressing and bending a plate material along its feeding direction through a three-point bending-press.

BACKGROUND ART

10 **[0002]** As a technique of producing a thick steel pipe of a large diameter used for a line pipe or the like is widely used a so-called UOE forming technique of press-working a steel plate having a predetermined length, width and plate thickness into a U-shape, press-forming the steel plate into an O-shape, butt-jointing the end portions thereof by welding to form a steel pipe, and further expanding its diameter (so-called tube expansion) so as to enhance the roundness.

15 **[0003]** However, in the above UOE forming technique, a high press pressure is required in the process of forming the steel plate into a U-shape and an O-shape by press-working the steel plate, so that it has no choice but to use a large-scale press machine.

[0004] For this reason, studies have been made on the technique for reducing the pressing pressure in the production of this type of steel pipe.

20 **[0005]** As a prior art in this regard, a bending-press forming technique has been put into practical use which performs the bending (edge bending) of the end portions in a widthwise direction of the steel plate in advance, then, forms the steel plate into a substantially circular shape by performing three-point bending-press a plurality of times, and further corrects the shape to form a steel pipe.

25 **[0006]** FIG. 9 is a view illustrating an embodiment of performing such a bending-press forming. The reference number 101 in FIG. 9 indicates a die disposed within a conveying pathway of a plate material S. The die 101 includes a pair of left and right rod-shaped members 101a and 101b which support the plate material S at two points along the conveying direction, and a distance e between the left and right rod-shaped members can be changed depending on the size of the steel pipe to be formed. However, in the course of producing an open pipe by press-forming the plate material S, the distance e is not changed.

30 **[0007]** A punch 102 is movable in a direction which gets close to and away from the die 101. The punch 102 includes a punch head 102a having a downward convex working surface K which comes into direct contact with the plate material S to press the plate material S into a concave shape, and a punch supporter 102b which leads to the back of the punch head 102a and supports the punch head 102a. The maximum width of the punch head 102a is generally equal to the width (thickness) of the punch supporter 102b. Also, a roller 103 forms a conveying pathway of the plate material S.

35 **[0008]** In the bending applied with the three-point bending-press, it is common to empirically determine the number of times of bending and a punch to be used (in particular, a shape), in consideration of load and product shape during bending (for example, a working width of the punch is about 120 mm, and the number of times of bending is about 50 to 60).

40 **[0009]** In the bending method, it is difficult to perform the efficient production as the number of times of bending is increased. As a countermeasure for this problem, for example, Patent Document 1 discloses a method wherein press-forming of a steel plate is conducted in the widthwise direction by performing the bending on both end portions and a specific intermediate portion in the widthwise direction of the steel plate such that each of the straight portions of desired lengths remain and a portion between the straight portions is a circular arc portion, simultaneously welding a joint portion to form a semi-forming round steel pipe, and after heating the entire semi-forming round steel pipe, performing the hot-forming throughout the plurality of forming rolls in which the forming surface has a semicircular shape corresponding to the final radius to thereby adjust a shape.

45 **[0010]** However, according to the disclosure of Patent Document 1, a formed body after the press-forming has a shape close to a square, and it is essential to separately provide a process (hot) for correcting the shape, so that there is a problem of causing a significant increase in the production cost when including the consumption of thermal energy applied to the heating.

50 **[0011]** Also, in this method, when a plate material produced via a thermo-mechanical heat-treatment process is used as an original plate to combine strength, toughness and weldability, there is a risk of deteriorating its characteristics.

[0012] Meanwhile, Patent document 2 discloses a method of reducing the number of times of bending in three-point bending-press, while diminishing the stress acting on a connecting portion between a punch head and a bending board for supporting the punch head (corresponding to the punch supporter).

55 **[0013]** According to Patent document 2, since the working width of the punch head is wider than the width of the bending board, it is possible to reduce the number of times of bending in the three-point bending-press as compared to the case of the punch head as shown in FIG. 9. Moreover, since the punch head is rotatably attached to the bending board, only a small bending moment caused by the friction of the rotating part acts on the bending board, and thus, there

is an advantage that the load applied to the equipment is reduced. However, since the rotating support portion has a smaller width than that of the bending board, there is a concern that a large surface pressure acts on the site to cause wear and deformation of the rotating support portion, and there is a possibility that the rotation function cannot be maintained at an early stage.

5 A further bending-press forming punch is disclosed in JP S56 50722 A.

PRIOR ART DOCUMENTS

PATENT DOCUMENTS

10

[0014]

Patent Document 1: JP-A-2005-324255

Patent Literature 2: JP-A-2004-82219

15

SUMMARY OF THE INVENTION

PROBLEM TO BE SOLVED BY THE INVENTION

20 **[0015]** As described above, in the conventional techniques, it is not easy to simply expand the working width of the punch head used in the bending-press forming, and in order to prevent the excessive load from being applied to the connecting portion between the punch head and the punch supporter while expanding the working width of the punch head, it is useful to sufficiently increase the width (thickness) of the punch supporter.

25 **[0016]** However, from the viewpoint of improving the accuracy in the process after the bending-press forming in recent years, it is required to reduce the width (thickness) of the punch supporter of the punch used in the bending-press forming.

[0017] Also, in the case of forming the plate material into a cylindrical shape by the bending-press forming to make a tubular body, even if the tubular body is removed along a longitudinal direction when the tubular body as a material to be formed is extracted from the punch, it is not theoretically possible to provide a gap between the plate width end portions facing each other in the tubular body which has a smaller width than the width (thickness) of the punch supporter.

30 **[0018]** In the tubular body (hereinafter, such a pipe is also referred to as open pipe) in the form of having a gap in which the plate material is formed into a cylindrical shape and the plate width end portions facing each other are not welded, when welding the plate width end portions facing each other (hereinafter, such a site is also referred to as a seam portion), it is necessary to deform the tubular body by applying force from the outside of the tubular body and to eliminate the gap by mutually butting the plate width end portions facing each other. Here, in the bending-press forming, as the gap between the plate width end portions is small, force required to butt the plate width end portions each other is small, and a bad shape such as roundness drop is also hard to occur. In this way, there has been an increasing demand for the technique of suppressing an increase in the width (thickness) of the punch supporter as much as possible while expanding the working width of the punch head in the bending-press forming.

35 **[0019]** Thus, an object of the present invention is to provide a bending-press forming tool capable of efficiently performing the bending, without causing wear and deformation of a punch or without impairing the product quality, in the production of the steel pipe from the plate material by the three-point bending-press.

40

MEANS FOR SOLVING PROBLEMS

45 **[0020]** The present invention provides a bending-press forming tool according to claim 1.

[0021] In the bending-press forming tool having the above-described configuration, it is preferable as a specific means for solving the problems of the present invention that:

50

- 1) The non-uniform circular arc comprises a continuous circular arc or a discontinuous circular arc,
- 2) The non-uniform circular arc comprises an involute curve,
- 3) When the non-uniform circular arc comprises the continuous circular arc or the discontinuous circular arc, the continuous circular arc and the discontinuous circular arc are constituted of a main circular arc having a radius corresponding to an inner diameter of a cylindrical body to be worked and laterally equivalent working widths (contact length) with respect to the working surface center, and a sub circular arc connecting with a width edge of the main circular arc and having a radius smaller than the radius,
- 4) Among the non-uniform circular arc, a circular arc primarily contributing to the bending has a working width of less than 0.90 times a feed pitch of the plate material, and
- 5) In the continuous circular arc and the discontinuous circular arc, the main circular arc has a working width of less

55

than 0.90 times the feed pitch of the plate material.

EFFECTS OF THE INVENTION

5 **[0022]** According to the bending-press forming tool of the invention having the above-described configuration, the punch head is provided with a working surface having a working surface center which matches an axis of the punch supporter and being formed by a non-uniform circular arc having a radius in a central region in the widthwise direction as a maximum radius. Thus, even if a bending range of the plate material is increased, the width end of the working surface does not strongly come into contact with the plate material, and it is possible to suppress an occurrence of excessive bending moment which may cause deformation or damage to the punch. Moreover, since it is possible to bend the plate materials having the width wider than that of the conventional technique at a time, a steel pipe having good roundness can be obtained with the small number of times of bending. Furthermore, a process such as heating the plate material is not necessary, whereby it is possible to maintain the characteristics such as strength, toughness and weldability or the like obtained in the producing process of the plate material (original plate).

10 **[0023]** Furthermore, according to the bending-press forming tool of the invention, the non-uniform circular arc is the continuous circular arc or the discontinuous circular arc obtained by combining at least two arcs with different radii, so that the width end of the working surface of the punch head does not strongly come into contact with the plate material at the time of bending. Therefore, it is possible to avoid an excessive bending moment which causes the deformation and damage to the punch. Also, it is relatively easy to form a working surface.

15 **[0024]** According to the bending-press forming tool having the above configuration, the working surface of the punch head can be easily formed by making the non-uniform circular arc of an involute curve.

20 **[0025]** Further, according to the bending-press forming tool of the invention, the continuous circular arc and the discontinuous circular arc are constituted of a main circular arc having a radius corresponding to an inner diameter of a steel pipe to be worked and laterally equivalent working widths with respect to the working surface center, and a sub circular arc connecting with a width edge of the main circular arc and having a radius smaller than the radius of the main circular arc. Thus, it is possible to reduce unbalance of forces acting on the punch by decreasing a difference in the distances from a contact starting point between the plate material and the punch head to the punch head center through the unformed side and the formed side portion of the plate material, which can avoid an extreme load being applied to the connecting portion between the punch head and the punch supporter while ensuring a wide working width of the punch head.

25 **[0026]** According to the bending-press forming tool of the present invention having the above configuration, in the working surface formed with the non-uniform circular arc, the working width of a region in which a circular arc primarily contributing to bending is formed is set to less than 0.90 times the feed pitch of the plate material, whereby an excessive bending moment does not occur in the punch. Accordingly, the life of the punch is extended to enable the stable bending over the long period of time, and the roundness of the steel pipe can be enhanced. In particular, when the non-uniform circular arc is a continuous circular arc or a discontinuous circular arc and the continuous circular arc or the discontinuous circular arc is constituted of the main circular arc and the sub circular arc, since the main circular arc primarily contributes to the bending, it is possible to suppress an occurrence of excessive bending moment by setting the working width of the region formed with the main circular arc to be less than 0.90 times the feed pitch of the plate material.

30

BRIEF DESCRIPTION OF DRAWINGS

[0027]

35 **[0027]** FIG. 1 is a schematic view illustrating an embodiment of a bending-press forming tool according to the present invention.

FIG. 2 is a schematic view illustrating a deformed state of a plate material when being pressed using the bending-press forming tool illustrated in FIG. 1.

FIGs. 3(a) to 3(c) are schematic views illustrating another embodiment of the bending-press forming tool.

40 FIG. 4 is a schematic view illustrating a bending way using the bending-press forming.

FIG. 5 is a schematic view illustrating a deformation situation of the plate material when performing the bending-press forming using a punch head having a uniform circular arc.

FIG. 6 is an explanation drawing of a working width n_1 which contributes to the bending of the punch.

FIG. 7 is a schematic view illustrating a specific dimension of the punch head used in the example.

45 FIG. 8(a) is a schematic view illustrating a dial gauge used when evaluating the local roundness of the steel pipe, and FIG. 8(b) is a schematic view illustrating how to measure the local roundness.

50 FIG. 9 is a schematic view illustrating an example of the embodiment when performing a bending-press forming according to the conventional method.

EMBODIMENTS FOR CARRYING OUT THE INVENTION

[0028] Hereinafter, the present invention will be described more specifically with reference to the accompanying drawings.

[0029] FIG. 1 is a schematic view illustrating an embodiment of a bending-press forming tool according to the present invention.

[0030] In the drawings, a die 1 is disposed within a conveying pathway of a plate material S. The die 1 includes a pair of left and right rod-shaped members 1a and 1b which support the plate material S at two locations along the feeding direction, and its distance e can be changed depending on the size of the steel pipe to be formed. However, in the course of producing a single open pipe by press-forming a plate material S, the distance e is not changed.

[0031] Also, a punch 2 is movable in a direction which gets come to and away from the die 1. The punch 2 includes a punch head 2a which has a downward convex working surface K coming into direct contact with the plate material S to press the plate material into a concave shape, and a punch supporter 2b which leads to the back of the punch head 2a and supports the punch head 2a. Also, rollers 3 form a conveying pathway of the plate material S.

[0032] A specific structure of the punch supporter 2b of the punch 2 is not illustrated, but its upper end portion is connected to a driving means such as a hydraulic cylinder so as to be able to apply the pressing force to the punch head 2a by the driving means.

[0033] A width (thickness) of the punch supporter 2b is appropriately designed by thickness and strength of the plate material S as a material to be formed and a shape of a tubular body to be formed. Also, since the punch supporter 2b may come into contact with the end portion of the plate material S, it is possible to provide a replaceable wearing plate on the surface of the punch supporter 2b. The wearing plate is preferable since it can be used for a long period of time without wearing the punch supporter 2b by appropriately exchanging it.

[0034] Moreover, as the main portions are illustrated in FIG. 2, the punch head 2a of the punch 2 has a working surface center O which matches an axis q of the punch supporter 2b, and a working surface K provided at its head is formed with a non-uniform circular arc which has a radius r_1 as a maximum radius in the central region in the widthwise direction (other regions have a radius r_2 which is smaller than the radius r_1).

[0035] Here, the non-uniform circular arc defined in the present invention refers to a circular arc provided by a combination as illustrated in FIGs. 3(a) to 3(c) in which at least two arcs having the different radii are combined with each other, that is, a circular arc which includes a circular arc of the radius r_1 positioned at the working surface center O (hereinafter, this circular arc is called a main circular arc K_1) and a circular arc having a smaller radius r_2 than that of the main circular arc K_1 (hereinafter, this circular arc is called a sub circular arc K_2). In FIGs. 3(a) to 3(c), (a) is a circular arc which has a common tangent at a connecting point between the main circular arc K_1 and the sub circular arc K_2 (when an angle formed by the tangent of the main circular arc K_1 and the tangent of the sub circular arc K_2 is 0°), and (b) is a circular arc in which the tangent of the main circular arc K_1 and the tangent of the sub circular arc K_2 are connected to each other while forming an angle (the angle is not 0°), and (c) is a circular arc in which an angle formed by the tangent of the main circular arc K_1 and the tangent of the sub circular arc K_2 is 0° but they are connected to each other via a step d. Hereinafter, the circular arc as illustrated in (a) will be referred to as a continuous circular arc (including a circular arc such as an involute curve or the like, in which a radius gradually is changed while having a common tangent), and the circular arcs as illustrated in (b) and (c) will be referred to as a discontinuous circular arc. The discontinuous circular arc also includes one in which the radius of the circular arc gradually is changed.

[0036] As described above, the punch 2 is basically configured to include the punch head 2a and the punch supporter 2b, but it is possible to interpose a spacer (not illustrated) between the punch head 2a and the punch supporter 2b. By interposing the spacer therebetween, for example, when finely adjusting a mounting angle of the punch head 2a to the punch supporter 2b, the mounting angle can be adjusted to an appropriate angle only by adjusting the shape of the spacer rather than the punch supporter 2b itself. Also, when the punch head 2a is divided in the longitudinal direction of the die 1, it is possible to improve the handling efficiency when storing the punch heads 2a or when mounting the punch heads 2a to the punch supporter 2b by holding the plurality of divided punch heads 2a with a single spacer. Since there are advantages as described above, it is preferable to interpose a spacer (not illustrated) between the punch head 2a and the punch supporter 2b.

[0037] To perform the bending of the plate material S by the bending press using a punch having the above-described configuration, the plate material S is placed on the die 1, and in such a manner as illustrated in FIG. 4, the plate material S may be successively subjected to the three-point bending both on the left and right sides from the edge in the widthwise direction towards the center by the punch 2 while intermittently feeding the plate material S by a predetermined feed pitch. In addition, FIG. 4 is a schematic view illustrating a process of forming an open pipe as illustrated in the right lowest view, by performing the bending of the plate material S which has been subjected to edge bending (to be described below) in advance, from the top to the bottom of the left column, then, from the top to the bottom of the center column, and further from the top to the bottom of the right column, and by performing the feeding of the plate material S. In FIG. 4, open arrows assigned to the plate material S or the punch 2 indicate the directions of movement of the plate material

S or the punch 2 in each process.

[0038] When performing the bending of the plate material S in the above-described manner (during pressing), the plate material S comes into contact with the die 1 in the state of being entirely inclined, and the plate material S is deformed in the state of left-right asymmetrical with respect to the working surface center O of the punch head 2a.

[0039] When the bending of the plate material S gradually progresses in this state, in order to maintain the state of contact between the punch 2 and the dies 1, the plate material S is greatly inclined on the unformed side rather than the center (working surface center O) in the widthwise direction of the punch head 2a (an bent angle of the plate material S with respect to the punch increases), and as illustrated in FIG. 5, a contact range (bending range) in which the punch head 2a comes into contact with the plate material S becomes wider on the unformed side than on the formed side.

[0040] Since the punch 2 receives the forming reaction force at both ends of the contact range, when there is a difference in distances (L_3, L_4) from the center (working surface center O) in the widthwise direction of the punch head 2a to both ends of the contact range, bending moment $M (= P (L_3 - L_4))$ acts on the connecting portion between the punch head 2a and the punch supporter 2b. In particular, in the three-point bending using a punch head with a working surface comprising a single circular arc, excessive bending moment acts. Accordingly, there is a concern that the punch head 2a or the punch supporter 2b may be deformed or damaged.

[0041] In the bending-press forming tool of the present invention, since the working surface K has the non-uniform circular arc and the radius of the sub circular arc K_2 is smaller than the radius of the main circular arc K_1 as illustrated in FIG. 2, it is possible to narrow the asymmetric range compared to a punch having a single working surface, and therefore, even when the bending of the plate material S progresses, the load in the width end region of the punch head 2a is not extremely increased, and as a result, an occurrence of the excessive bending moment can be suppressed.

[0042] In the present invention, in order to obtain a steel pipe with good roundness by the bending-press forming, the main circular arc K_1 formed on the working surface K has laterally equivalent contact lengths with respect to the working surface center O as a starting point.

[0043] Further, although the main circular arc K_1 and the sub circular arc K_2 are constituted of a continuous circular arc or a discontinuous circular arc, the number of circular arcs is not particularly limited.

[0044] Although the length (circumferential length) of the working surface K is determined by the size of the steel pipe to be manufactured and the number of times of pressing, the working width of the working surface K in the region formed by a circular arc primarily contributing to the bending is preferably less than 0.90 times the feed pitch of the plate material so as to diminish the bending moment occurring in the punch 2 and decrease the number of times of pressing to achieve the efficient bending (when the working width of the region formed with a circular arc primarily contributing to the bending is set to n_i and the feed pitch of the plate material S is set to δ , a ratio (n_i/δ) of the working width n_i and the feed pitch δ of the plate material S is less than 0.90 times). In the punch head 2a where the working surface K is formed with the main circular arc K_1 and the sub circular arc K_2 , the main circular arc K_1 primarily contributes to the bending, so that the working width of the region formed by the main circular arc K_1 is set to less than 0.90 times the feed pitch δ of the plate material.

[0045] Here, when a target bending formation amount θ_i (a bending angle per time) is set around the working surface center O on the working surface K of the punch head 2a, the working width n_i of the region formed with the circular arc primarily contributing to the bending refers to a length (length of a circular arc) on the working surface K corresponding to a range of the target bending formation amount θ_i as illustrated in FIG. 6. Also, when the number of times of bending is assumed to be N, since the plate material is bent into a pipe shape of 360° together with the edge bending, the target bending formation amount θ_i is $(360^\circ - 2 \times \text{edge bending angle})/N$ is a measure of the amount of the bending formation per time.

[0046] In the bending press using the punch 2 of the present invention, the number of times of bending N is normally not less than 3, so that 120° which is the value calculated when the edge bending angle is assumed to be 0° is sufficient as the target value of the amount of the bending formation per time. Accordingly, the bending formation amount on the working surface K of the punch 2 being set not more than 120° (corresponding to not more than 60° on each side from the working surface center O of the punch 2), or may be further decreased to not more than 90° (corresponding to not more than 45° on each side from the working surface center O of the punch 2).

[0047] In general, when forming the plate material into a tubular shape by the bending-press forming, the edge bending (also referred to as crimping) is performed on the plate width end portions of the plate material prior to the bending-press forming. This is implemented in order to ensure good roundness of the plate width end portions which are relatively hard to bend as compared to the case of performing the bending of the plate width central portion in the bending-press forming. Further, since the plate material has a pipe shape by performing the bending of 360° together with the subsequent bending-press forming, in the bending-press forming, the bending is applied except for the amount given by the edge bending. The bending formation amount (angle) θ_i per time in the bending press is $(360^\circ - 2 \times \text{edge bending angle})/N$, and the range applied with the bending per time is the feed amount (feed pitch). In other words, the plate material is formed into a pipe shape by giving the bending formation amount θ_i every feed pitch.

[0048] At this time, when the plate material goes along the working surface K of the punch head 2a, the shape of the

range of the bending formation amount (central angle) θ_i is transferred onto the punch head 2a to obtain the shape after the bending press. As the length (peripheral length (or circular arc length)) along the working surface K of the section of the bending formation amount θ_i approaches the feed pitch of the plate material, the portion to which the radius of curvature is given is widened, and the good roundness can be secured. However, when the bending range is widened,

the position receiving the forming reaction force (bending reaction force) becomes remote from the working surface center O of the working surface K of the punch head 2a, and there is a problem of increasing the bending moment at the connecting portion between the punch supporter 2b and the punch head 2a. In order to reduce such problems, in the present invention, the working width n_i of the region formed with the circular arc primarily contributing to the bending is set to less than 0.90 times the feed amount (length) of the plate material.

[0049] Also, when bending the plate material S with the punch head 2a having a smaller radius than the radius of the product, the radius of curvature of the bent portion of the plate material S is also decreased. In this case, a bending forming portion having a radius of curvature locally smaller than that of other portions is also formed in the tubular body which is made of the plate, so that the shape is degraded if the portion remains in the product as it is. Since the radius of the sub circular arc K_2 of the working surface K is smaller than the radius of the main circular arc K_1 , it is necessary to pay attention to the occurrence of such a failure. For that reason, the bending range of the sub circular arc K_2 is preferably set to not more than 15° at the central angle of the sub circular arc K_2 .

[0050] When the length of the working surface coming into contact with the plate material is shortened, since the portion to which the curvature is not given (that is, flat portion) is increased and there is a risk of degradation of roundness, it is preferable to appropriately set the working width (distance) n_i of the region where the circular arc primarily contributing to the bending is formed, depending on the specifications (strength, thickness, size and shape) of the target product.

EXAMPLES

[0051] Nine steel plates (steel type: API grade. X80) having dimensions along the feeding direction of the plate material S of 3713 mm, a plate thickness of 25.4 mm and a tensile strength of 745 to 757 MPa are prepared, and the edge bending is performed so that both end portions of each steel plate has an angle of 16.9 degrees over the range of 215 mm by a punch having a radius of curvature of 380 mm.

[0052] Subsequently, the three-point bending is performed from each of both the left and right sides toward the center of the steel plate based on the conditions of a feed pitch 298 mm/time, a bending formation amount 29.6° /time and five times of press by using a position of one side 1492 mm from the center of the steel plate (the center of the dimension along the feeding direction) as the bending start point.

[0053] Then, one three-point bending is conducted on the steel plate subjected to the three-point bending at the center (11 times of bending in total), and the gap of the butted part of both ends of the steel plate is set to 125 mm, which is welded to form a steel pipe having an outer diameter of 1219 mm, and the quality of the obtained steel pipe and the stress acting on the punch supporter for supporting the punch head is investigated. The results are shown in Table 1 together with the results of the case of performing the bending using the punch head 2a provided with a working surface of a single circular arc.

[0054] Here, the bending is performed using a die where a radius of the head is set to 75 mm and a distance e (distance between centers) between the rod-shaped members 1a and 1b is set to 550 mm. Also, the punch head having the width of 400 mm is used, and the punch supporter having a width (thickness) of the body portion of 100 mm and a receiving portion of the width 400 mm to fix and hold the punch head to the tip is used for supporting it as illustrated in FIG. 7. A strain gauge is attached to an end portion (start site of R) of R having the radius of 50 mm provided in the connecting portion between the body portion and the receiving portion, thereby measuring the stress acting on the punch supporter 2b by the gauge.

[0055] In addition, the form of the working surface is a continuous circular arc in the item of Table 1 when performing the bending by the use of a punch head having a working surface in which the main circular arc and the sub circular arc are connected to each other with an angle of 0° formed between the tangent of the main circular arc and the tangent of the sub circular arc, at the position of the angle of 15° from the working surface center O of the punch head. The form of the working surface is an involute when performing the bending by the use of a punch head having a working surface in which the radius is gradually decreased as being remote from the working surface center O of the punch head by the involute curve. In the case of the involute, the radius of the main circular arc indicates the value of the radius in the working surface center O (that is, the maximum value of the radius), and the radius of the sub circular arc indicates the position which is remote from the working surface center O by 1/2 of the bending formation amount θ_i : 29.6° , that is, the minimum value of the radius of the range primarily contributing to the bending, respectively. Moreover, the form of the working surface is a discontinuous circular arc when performing the bending by the use of a punch head having a working surface in which the main circular arc and the sub circular arc are connected to each other with a difference of 6° of the angles formed between the tangent of the main circular arc and the tangent of the sub circular arc at the positions of 15° from the working surface center O of the punch head 2a.

EP 3 127 624 B1

[0056] Also, in the ratio of the stress acting on the punch supporter to the fatigue limit stress in Table 1, the stress acting on the punch supporter indicates the largest value in the 11 times of bending. However, it is required to consider in the execution how much the stress acting on the punch supporter with respect to the fatigue limit stress is. Therefore, in Table 1 are shown values obtained by dividing the stress acting on the punch supporter by a basic allowable stress range in 2×10^6 times of stress repetition based on "Fatigue design guideline and commentary of steel structure (Hagane-Kouzou no Hirou Sekkei Shishin · Dou Kaisetsu)" edited by Japanese Society of Steel Construction, regarding the punch supporter, that is, the ratio of stress acting on the punch supporter to the basic allowable stress range.

[0057] In the evaluation of punch head, a case where the stress acting on the punch supporter is lower than the fatigue limit stress, that is, a case where the ratio of the stress acting on the punch supporter to the fatigue limit stress is less than 1, is indicated by ◎ (excellent), a case where the ratio of stress is not more than 1.25 is indicated by ○ (allowable), and a case where the ratio is more than that value is indicated by × (unallowable). Here, the ratio 1.25 of the stress in which the number of times of stress repetition is not less than 1×10^6 is a threshold value. In the case of not more than the threshold value, since the repeated stress acts 10 times on the one pipe (the substantially symmetrical formation is obtained in the last 11-th time, and the stress due to the bending hardly acts and does not affect the fatigue life), it is possible to withstand the producing of 1×10^5 pipes (equivalent to 1219 km in the case the standard 40ft length), and there is no practical problem.

[0058] Further, the evaluation of the steel pipe in Table 1 is carried out for local roundness. The local roundness is measured by, for example, using a dial gauge 4 having a pair of leg portions 4a and 4b with an inter-leg distance of D as illustrated in FIG. 8(a), by contacting leg ends 4c, 4d of the leg portions 4a, 4b with the peripheral surface of the resultant steel pipe and simultaneously contacting a probe (not illustrated) provided at the tip of a spindle 4e with the peripheral surface of the steel pipe, and by reading a radial displacement from a virtual perfect circle as a target shape of the steel pipe. It means that the circle gets close to a perfect circle as the value is smaller. In this embodiment, it is an evaluation index of the variation of the shape between the portion which contacts with the punch head and the die and the portion which does not with the punch head and the die. Here, a dial gauge having an inter-leg distance D of 150 mm is used to measure the local roundness as illustrated in FIG. 8(b) along the circumferential direction of the peripheral surface of the steel pipe and obtain the maximum value of the measured local roundness. A case where the value is not more than the tolerance 2.0 mm of API-2B of the API standard as a typical standard of the steel pipe is indicated by ◎ (excellent), a case where the value is not more than the tolerance 3.2 mm of API-5L is indicated by ○ (good), and a case where the value exceeds that is indicated by × (unallowable) in Table 1.

[Table 1]

Punch No.	Punch						Steel Pipe		Remarks
	Radius of main circular arc (mm)	Radius of sub circular arc (mm)	Ratio of stress acting on punch supporter to fatigue limit stress	Evaluation	Form of machining surface	n/δ	Maximum value of local roundness (mm)	Evaluation	
A	480	290	0.87	◎	continuous circular arc	0.84	2.0	◎	Present invention
B	480	350	1.10	○	continuous circular arc	0.84	1.9	◎	Present invention
C	480	400	1.25	○	continuous circular arc	0.84	1.8	◎	Present invention
D	480	417	0.94	◎	involute	0.78	2.3	○	Present invention
E	480	433	1.02	○	involute	0.80	20	◎	Present invention
F	500	425	1.25	○	involute	0.81	1.7	◎	Present invention
G	480	340	0.97	◎	discontinuous circular arc	0.84	2.2	○	Present invention
H	480	360	1.02	○	discontinuous circular arc	0.84	2.1	○	Present invention
I	510	340	1.30	×	discontinuous circular arc	0.90	2.1	○	Comparative example
J	480	-	1.37	×	single circular arc	0.84	2.3	○	Comparative example
K	455	-	1.16	○	single circular arc	0.80	3.1	×	Comparative example
L	420	-	0.97	◎	single circular arc	0.74	3.5	×	Comparative example

[0059] As is apparent from Table 1, in the punch Nos. A to H suitable for the present invention, the ratio of stress applied to the punch supporter during bending is not more than 1.25, and the deformation and damage of the punch is not observed. In addition, it is confirmed that the local roundness of the steel pipe formed by the punch Nos. A to H is not more than 2.3 mm and sufficiently satisfies the standard API.

[0060] In particular, in a case where the working surface of the punch head is formed by a continuous circular arcs (Nos. A, B, C, E and F), the local roundness of the steel pipe is not more than 2.0 mm and satisfied the strict 2B standard in the API standard, and it is found clear that a steel pipe of high quality can be formed without adding extra processes.

[0061] When applying the continuous circular arc to the working surface of the punch head, in punch No. A having the smallest radius of the sub circular arc, the ratio of the stress in the connecting portion is the smallest as 0.87, and it is found that this is permanently usable for such a punch supporter.

[0062] In contrast, in punch No. I in which the ratio (n_i/δ) of the working width (n_i) of the region primarily contributing to the bending and the feed pitch (δ) of the plate material is 0.90, even in the case of the non-uniform circular arc, the ratio of stress applied to the punch supporter is large as 1.30, and there is a risk of deformation and damage of the punch.

[0063] Furthermore, in the bending using a punch having a punch head with a working surface of a single circular arc, in the case of applying punch No. J having the working surface with the radius of 480 mm, the ratio of the stress applied to the punch supporter is increased, and there is a risk of deformation or damage of the punch. Meanwhile, in the case of applying punch Nos. K and L having a working surface with a radius of 455 mm, or 420 mm, it is found that there is a tendency of deterioration of the local roundness of the steel pipe.

INDUSTRIAL APPLICABILITY

[0064] According to the present invention, it is possible to provide a bending-press forming tool in which impact on deformation and damage of the punch due to an occurrence of excessive bending moment is suppressed to stably and efficiently form the steel pipe with good roundness over long period of time.

DESCRIPTION OF REFERENCE SYMBOLS

[0065]

- 1, 101 die
- 1a, 101a rod-shaped member
- 1b, 101b rod-shaped member
- 2, 102 punch
- 2a, 102a punch head
- 2b, 102b punch supporter
- 3, 103 roller
- 4 dial gauge
- 4a leg portion
- 4b leg portion
- 4c leg end
- 4d leg end
- 4e spindle
- S plate material
- e distance
- K working surface
- K_1 main circular arc
- K_2 sub circular arc
- r_1 radius
- r_2 radius
- O working surface center
- q pressing axis

Claims

1. A bending-press forming tool comprising: dies (1) that are disposed at intervals along a feeding direction of a plate material (S) to support the plate material (S) at two locations and a punch (2) that is movable in a direction of getting close to or away from the dies (1) and sequentially presses the plate material (S) supported by the dies (1) along

the feeding direction to perform bending,

wherein the punch (2) has a punch head (2a) that directly contacts with the plate material (S) to press the plate material (S), and a punch supporter (2b) that is connected to the back of the punch head (2a) and supports the punch head (2a), and

the punch head (2a) is provided with a working surface (K) having a working surface center (O) which matches an axis of the punch supporter (2b), being formed by a non-uniform circular arc,

characterized in that a radius in a central region in the widthwise direction of the non-uniform circular arc is a maximum radius (r_1) and being set not more than 120° as a bending angle and having a working width (n_i) being set not more than 60° on each side from the working surface center (O) of the punch (2).

2. The bending-press forming tool according to claim 1, wherein the non-uniform circular arc is a continuous circular arc or a discontinuous circular arc obtained by combining at least two arcs having different radii.
3. The bending-press forming tool according to claim 1, wherein the non-uniform circular arc includes an involute curve.
4. The bending-press forming tool according to claim 2, wherein the continuous circular arc or the discontinuous circular arc includes a main circular arc (K_1) which has a radius corresponding to an inner diameter of a steel pipe to be manufactured and has laterally identical working widths with respect to the working surface center (O), and a sub circular arc (K_2) which leads to a width edge of the main circular arc (K_1) and has a radius (r_2) smaller than the radius (r_1).
5. The bending-press forming tool according to any one of claims 1 to 3, wherein a region of the non-uniform circular arc, in which a circular arc primarily contributing to the bending is formed, has a working width of less than 0.90 times a feed pitch of the plate material (S).
6. The bending-press forming tool according to claim 4, wherein a region of the continuous circular arc or the discontinuous circular arc, in which the main circular arc (K_1) is formed, has a working width of less than 0.90 times the feed pitch of the plate material (S).

Patentansprüche

1. Biege-Press-Formwerkzeug, das umfasst:

Unterwerkzeuge (1), die in Abständen entlang einer Vorschubrichtung eines Plattenmaterials (S) angeordnet sind und das Plattenmaterial (S) an zwei Positionen tragen, sowie einen Stempel (2), der in einer Richtung bewegt werden kann, in der er sich den Unterwerkzeugen (1) nähert oder sich von ihnen entfernt, und das von den Unterwerkzeugen (1) getragene Plattenmaterial (S) entlang der Vorschubrichtung sequentiell presst, um Biegen durchzuführen, wobei der Stempel (2) einen Stempel-Kopf (2a), der direkt mit dem Plattenmaterial (S) in Kontakt kommt, um das Plattenmaterial (S) zu pressen, sowie einen Stempel-Träger (2b) aufweist, der mit der Rückseite des Stempel-Kopfes (2a) verbunden ist und den Stempel-Kopf (2a) trägt, und der Stempel-Kopf (2a) mit einer Arbeitsfläche (K) versehen ist, die eine Arbeitsflächen-Mitte (O) hat, die mit einer Achse des Stempel-Trägers (2b) übereinstimmt, die durch einen ungleichmäßigen Kreisbogen gebildet wird,

dadurch gekennzeichnet, dass ein Radius in einem mittleren Bereich in der Breitenrichtung des ungleichmäßigen Kreisbogens ein maximaler Radius (r_1) ist und auf nicht mehr als 120° als ein Biegewinkel eingestellt ist und eine Arbeitsbreite (n_i) hat, die auf nicht mehr als 60° an jeder Seite von der Arbeitsflächen-Mitte (O) des Stempels aus eingestellt ist.

2. Biege-Press-Formwerkzeug nach Anspruch 1, wobei der ungleichmäßige Kreisbogen ein kontinuierlicher Kreisbogen oder ein diskontinuierlicher Kreisbogen ist, der sich durch Kombination wenigstens zweier Bögen mit unterschiedlichen Radien ergibt.
3. Biege-Press-Formwerkzeug nach Anspruch 1, wobei der ungleichmäßige Kreisbogen eine Abwicklungskurve einschließt.

4. Biege-Press-Formwerkzeug nach Anspruch 2, wobei der kontinuierliche Kreisbogen oder der diskontinuierliche Kreisbogen einen Haupt-Kreisbogen (K_1), der einen Radius hat, der einem Innendurchmesser eines herzustellenden Stahlrohres entspricht und seitlich identische Arbeitsbreiten in Bezug auf die Arbeitsflächen-Mitte (O) hat, sowie einen Neben-Kreisbogen (K_2) aufweist, der zu einer Breiten-Kante des Haupt-Kreisbogens (K_1) führt und einen Radius (r_2) hat, der kleiner ist als der Radius (r_1).
5. Biege-Press-Formwerkzeug nach einem der Ansprüche 1 bis 3, wobei ein Bereich des ungleichmäßigen Kreisbogens, in dem ein hauptsächlich zu dem Biegen beitragender Kreisbogen ausgebildet ist, eine Arbeitsbreite von weniger als dem 0,90-fachen eines Vorschubschrittes des Plattenmaterials (S) hat.
6. Biege-Press-Formwerkzeug nach Anspruch 4, wobei ein Bereich des kontinuierlichen Kreisbogens oder des diskontinuierlichen Kreisbogens, in dem der Haupt-Kreisbogen (K_1) ausgebildet ist, eine Arbeitsbreite von weniger als dem 0,90-fachen des Vorschubschrittes des Plattenmaterials (S) hat.

Revendications

1. Outil de formation par pliage-presse comprenant : des matrices (1) qui sont disposées à intervalles le long d'une direction d'alimentation d'un matériau en plaque (S) pour soutenir le matériau en plaque (S) à deux emplacements et un poinçon (2) qui est mobile dans une direction pour se rapprocher ou s'éloigner des matrices (1) et appuie séquentiellement sur le matériau en plaque (S) soutenu par les matrices (1) le long de la direction d'alimentation pour exécuter un pliage,

dans lequel le poinçon (2) présente une tête de poinçonnage (2a) qui entre directement en contact avec le matériau en plaque (S) pour appuyer sur le matériau en plaque (S), et un élément de soutien de poinçon (2b) qui est connecté à l'arrière de la tête de poinçonnage (2a) et soutient la tête de poinçonnage (2a), et la tête de poinçonnage (2a) est dotée d'une surface de travail (K) présentant un centre de surface de travail (O) qui correspond à un axe de l'élément de soutien de poinçon (2b), étant constitué d'un arc circulaire non uniforme,

caractérisé en ce qu'un rayon dans une zone centrale dans la direction de largeur de l'arc circulaire non uniforme est un rayon maximal (r_1) et étant défini inférieur à 120° en tant qu'angle de pliage et présentant une largeur de travail (n_1) étant définie inférieure à 60° sur chaque côté depuis le centre de surface de travail (O) du poinçon (2).

2. L'outil de formation par pliage-presse selon la revendication 1, dans lequel l'arc circulaire non uniforme est un arc circulaire continu ou un arc circulaire discontinu obtenu en combinant au moins deux arcs présentant des rayons différents.
3. L'outil de formation par pliage-presse selon la revendication 1, dans lequel l'arc circulaire non uniforme inclut une courbe développante.
4. L'outil de formation par pliage-presse selon la revendication 2, dans lequel l'arc circulaire continu ou l'arc circulaire discontinu inclut un arc circulaire principal (K_1) qui présente un rayon correspondant à un diamètre intérieur d'un tube d'acier à fabriquer et présente des largeurs de travail latéralement identiques par rapport au centre de surface de travail (O), et un sous-arc circulaire (K_2) qui conduit à une arête de largeur de l'arc circulaire principal (K_1) et présente un rayon (r_2) inférieur au rayon (r_1).
5. L'outil de formation par pliage-presse selon l'une quelconque des revendications 1 à 3, dans lequel une zone de l'arc circulaire non uniforme, dans laquelle un arc circulaire contribuant essentiellement au pliage est formé, présente une largeur de travail de moins de 0,90 fois un pas d'alimentation du matériau en plaque (S).
6. L'outil de formation par pliage-presse selon la revendication 4, dans lequel une zone de l'arc circulaire continu ou de l'arc circulaire discontinu, dans laquelle l'arc circulaire principal (K_1) est constitué, présente une largeur de travail de moins de 0,90 fois le pas d'alimentation du matériau en plaque(S).

FIG 3

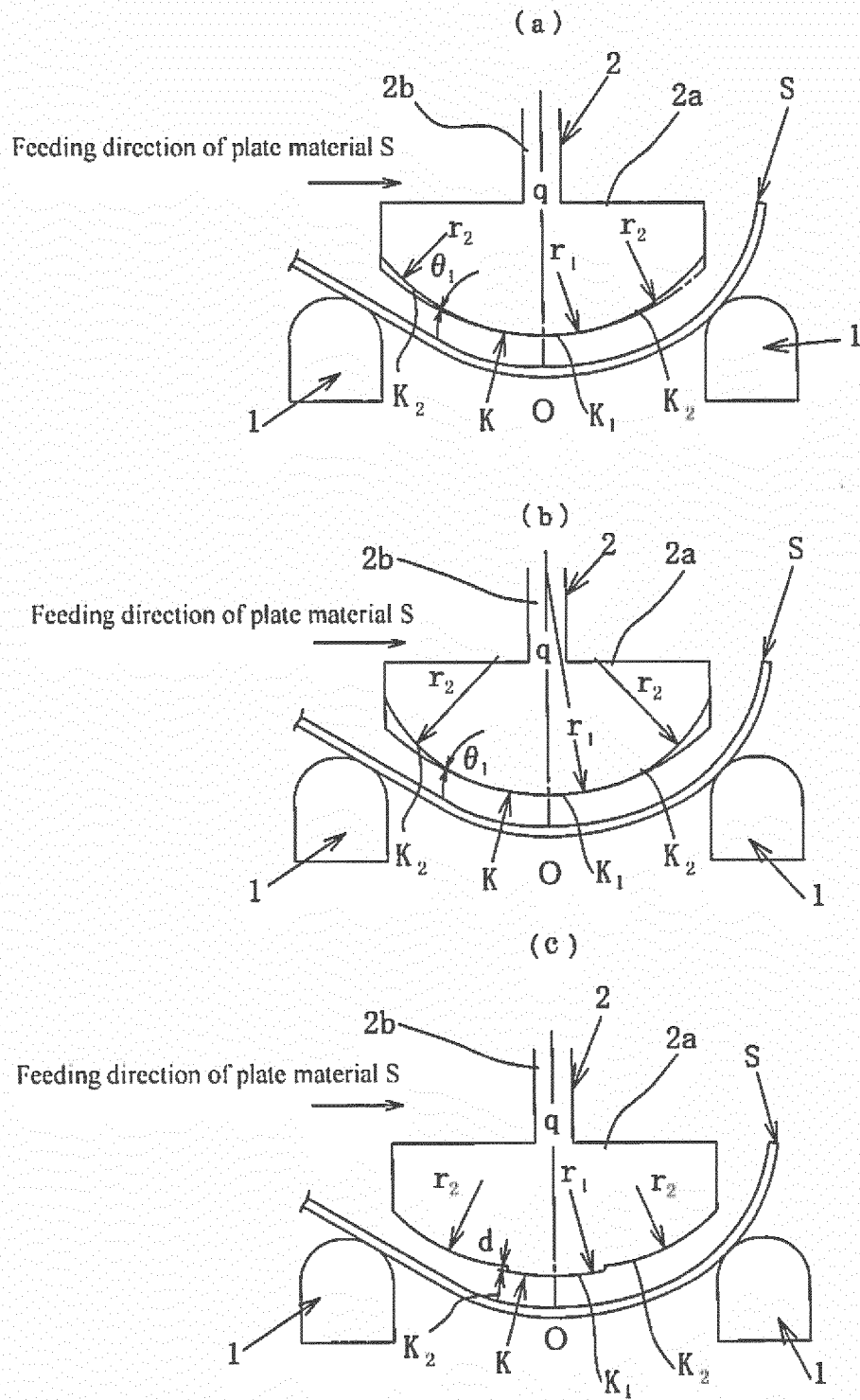

FIG. 4

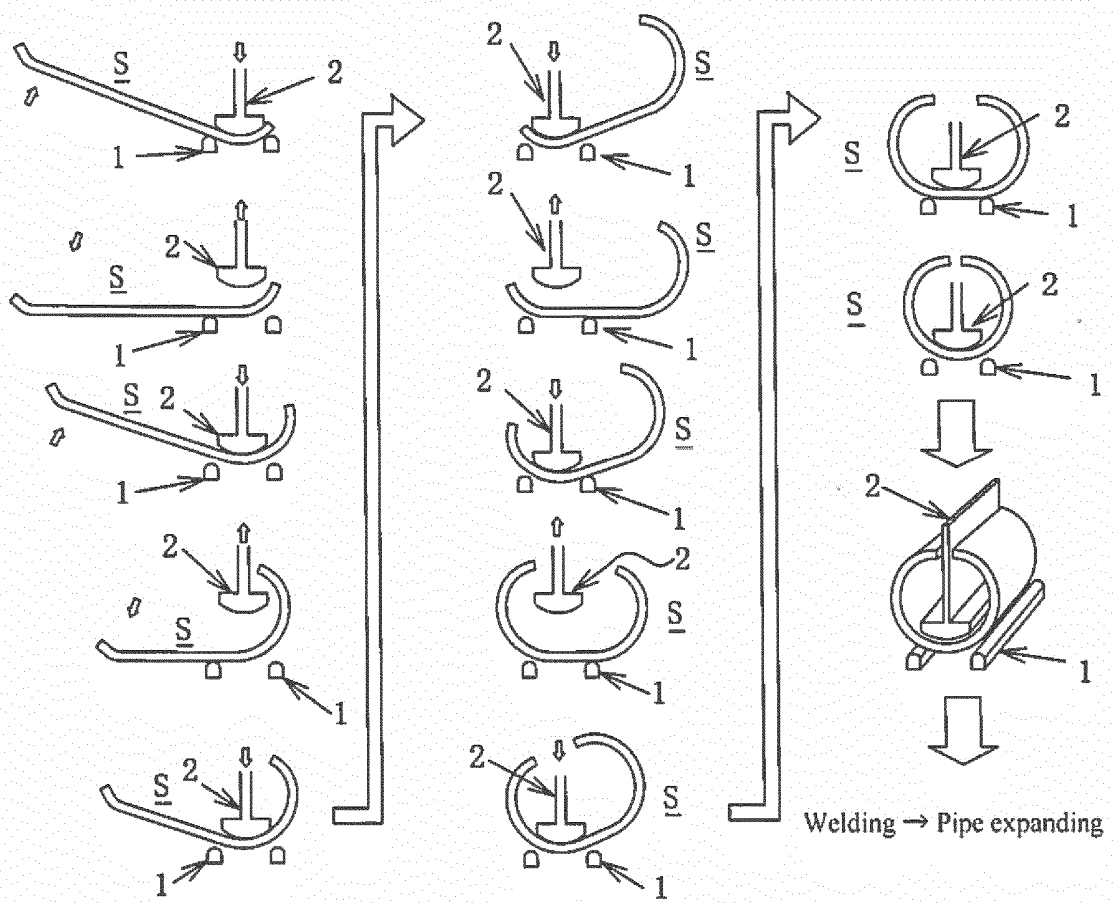

FIG. 5

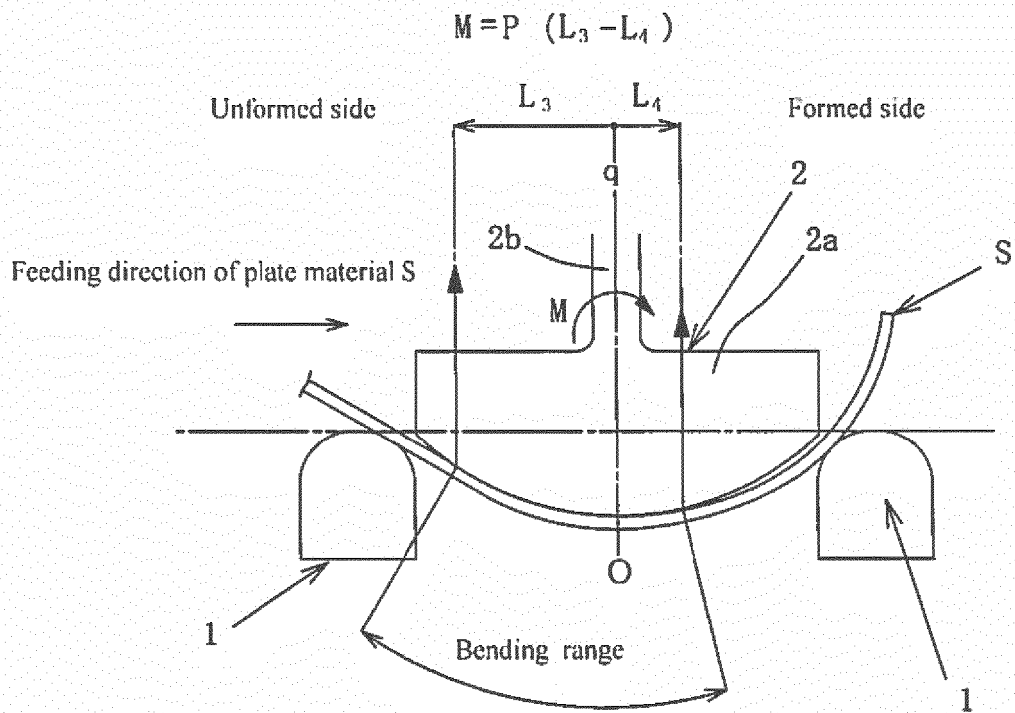

FIG. 6

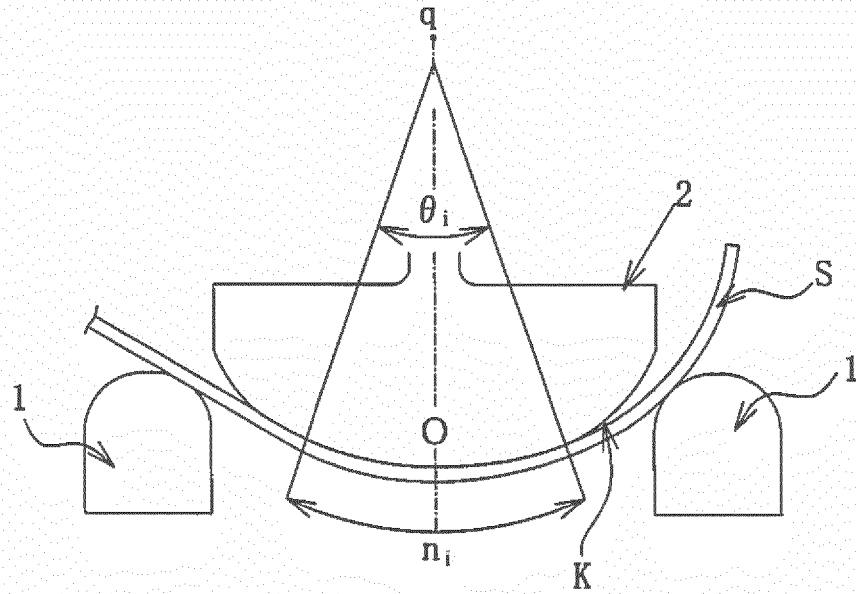

FIG. 7

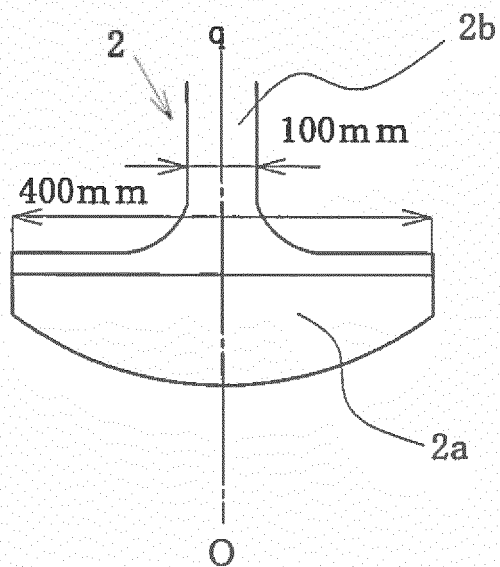

FIG. 8

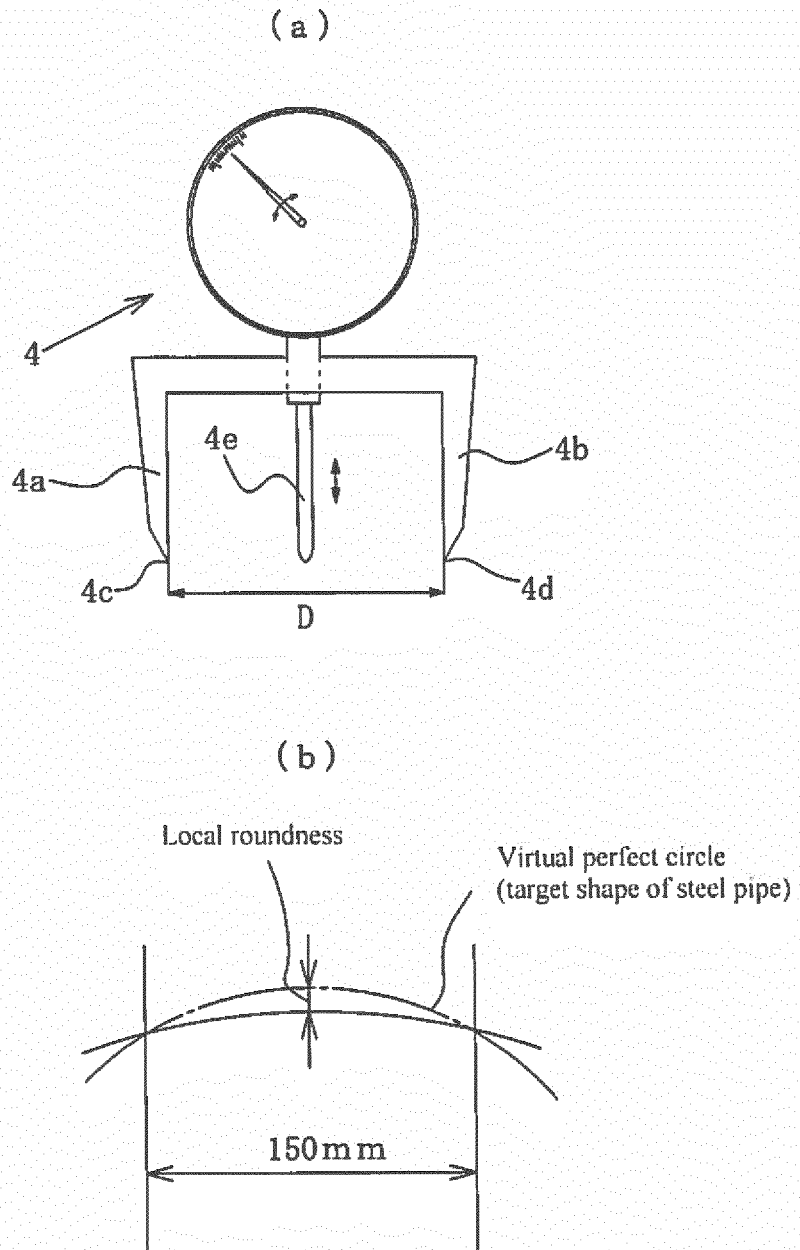
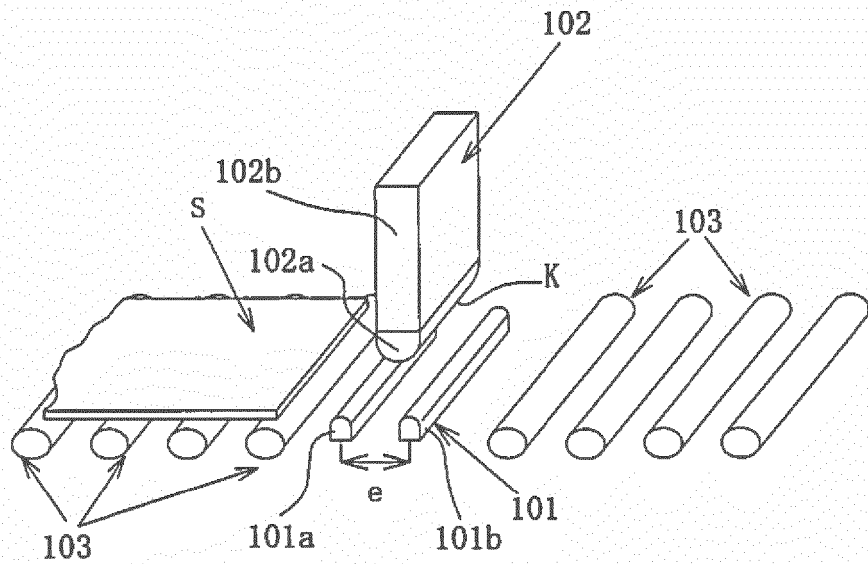

FIG. 9



REFERENCES CITED IN THE DESCRIPTION

This list of references cited by the applicant is for the reader's convenience only. It does not form part of the European patent document. Even though great care has been taken in compiling the references, errors or omissions cannot be excluded and the EPO disclaims all liability in this regard.

Patent documents cited in the description

- JP S5650722 A [0013]
- JP 2005324255 A [0014]
- JP 2004082219 A [0014]