



INTERNATIONAL APPLICATION PUBLISHED UNDER THE PATENT COOPERATION TREATY (PCT)

<p>(51) International Patent Classification ⁶ : G09G 3/22</p>	<p>A1</p>	<p>(11) International Publication Number: WO 00/14710 (43) International Publication Date: 16 March 2000 (16.03.00)</p>
<p>(21) International Application Number: PCT/US98/18599 (22) International Filing Date: 4 September 1998 (04.09.98) (71)(72) Applicant and Inventor: FAN, Nongqiang [CN/US]; 3855 Woodhollow, Apt. 216, Euless, TX 76040 (US).</p>		<p>(81) Designated States: JP, European patent (AT, BE, CH, CY, DE, DK, ES, FI, FR, GB, GR, IE, IT, LU, MC, NL, PT, SE). Published <i>With international search report.</i> <i>With amended claims and statement.</i></p>

(54) Title: METHODS OF IMPROVING DISPLAY UNIFORMITY OF THIN CRT DISPLAYS BY CALIBRATING INDIVIDUAL CATHODE

(57) Abstract

Methods of improving the display uniformity of a thin CRT display are disclosed. These methods can provide nearly perfect display uniformity for a thin CRT display despite the fact that the emission characteristics of those cathodes in the thin CRT display are intrinsically non-uniform due to the inevitable manufacture variations. In order to improve the display uniformity of a thin CRT display, the emission characteristics of all cathodes are measured, and calibration parameters for each cathode are obtained from the measured emission characteristics of the corresponding cathode. The calibration parameters of each cathode are stored in a calibration memory (70) as a complete look-up table or a partial look-up table. With a complete look-up table, when the CPUs want to display a pixel with a desired luminosity, it will use the complete look-up table of the corresponding cathode to find the correct driving parameters. With a partial look-up table, when the CPU wants to display a pixel with a desired luminosity, it will use the partial look-up table of the corresponding cathode in combination with additional calculation to find the correct driving parameters, and these calculations can be performed with the main CPU or a dedicated display processor (60).

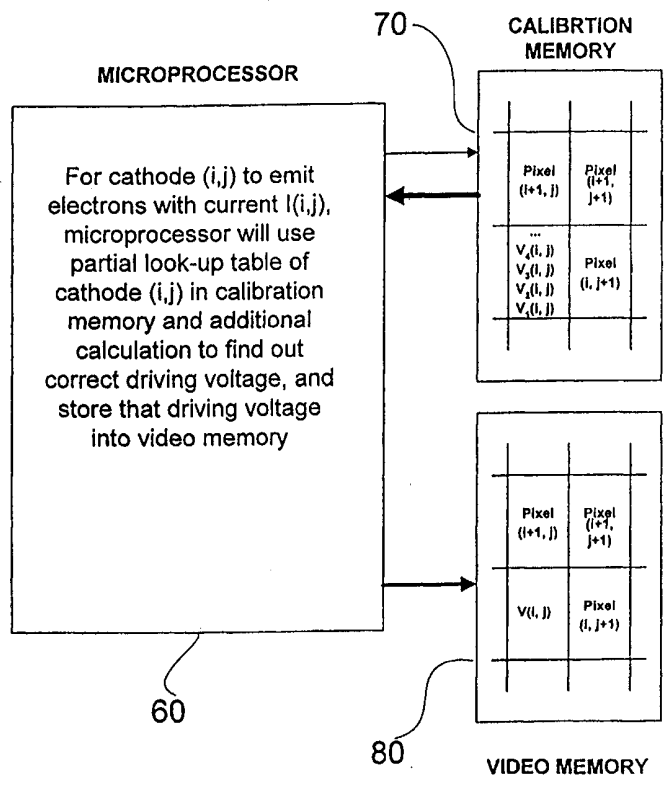

60

80

70

FOR THE PURPOSES OF INFORMATION ONLY

Codes used to identify States party to the PCT on the front pages of pamphlets publishing international applications under the PCT.

AL	Albania	ES	Spain	LS	Lesotho	SI	Slovenia
AM	Armenia	FI	Finland	LT	Lithuania	SK	Slovakia
AT	Austria	FR	France	LU	Luxembourg	SN	Senegal
AU	Australia	GA	Gabon	LV	Latvia	SZ	Swaziland
AZ	Azerbaijan	GB	United Kingdom	MC	Monaco	TD	Chad
BA	Bosnia and Herzegovina	GE	Georgia	MD	Republic of Moldova	TG	Togo
BB	Barbados	GH	Ghana	MG	Madagascar	TJ	Tajikistan
BE	Belgium	GN	Guinea	MK	The former Yugoslav Republic of Macedonia	TM	Turkmenistan
BF	Burkina Faso	GR	Greece	ML	Mali	TR	Turkey
BG	Bulgaria	HU	Hungary	MN	Mongolia	TT	Trinidad and Tobago
BJ	Benin	IE	Ireland	MR	Mauritania	UA	Ukraine
BR	Brazil	IL	Israel	MW	Malawi	UG	Uganda
BY	Belarus	IS	Iceland	MX	Mexico	US	United States of America
CA	Canada	IT	Italy	NE	Niger	UZ	Uzbekistan
CF	Central African Republic	JP	Japan	NL	Netherlands	VN	Viet Nam
CG	Congo	KE	Kenya	NO	Norway	YU	Yugoslavia
CH	Switzerland	KG	Kyrgyzstan	NZ	New Zealand	ZW	Zimbabwe
CI	Côte d'Ivoire	KP	Democratic People's Republic of Korea	PL	Poland		
CM	Cameroon	KR	Republic of Korea	PT	Portugal		
CN	China	KZ	Kazakstan	RO	Romania		
CU	Cuba	LC	Saint Lucia	RU	Russian Federation		
CZ	Czech Republic	LI	Liechtenstein	SD	Sudan		
DE	Germany	LK	Sri Lanka	SE	Sweden		
DK	Denmark	LR	Liberia	SG	Singapore		
EE	Estonia						

METHODS OF IMPROVING DISPLAY UNIFORMITY OF THIN CRT DISPLAYS BY CALIBRATING INDIVIDUAL CATHODE

This invention is related to thin CRT displays, and specially to a method for improving the display uniformity of thin CRT displays.

BACKGROUND OF THE INVENTION

5 A thin CRT display is a type of flat panel display which uses a matrix of cold cathodes to emit electrons towards an anode faceplate coated with phosphors. The most promising type of thin CRT displays use Spindt field emission cathodes, and they are often called Field Emission Displays (FED). Another promising type of thin CRT displays use Surface Conducting Electron (SCE) cathodes developed by Canon. And
10 other kinds of cold cathode which can be used to construct thin CRT displays include MIS cathodes developed by Pioneer Electric Corp. (which is also called High Efficiency Electron-Emission Device, or Heed) , Silicon avalanche cathodes developed by Philip, diamond cathodes developed by SI Diamond, MIM cathodes, pn junction cathodes and Schottky junction cathodes.

15 Thin CRT displays have the potential to provide image qualities comparable to conventional CRT displays. But, because the light intensity of each pixel is determined by the electron emission characteristics of one or more cold cathodes behind the phosphors segment of that pixel, it is difficult to make thin CRT displays with uniform display intensity. The variations of the display intensity is due to the variations of the
20 electron emission characteristics of all the cathodes. The variations of the electron emission characteristics are inevitable, because large numbers of cathodes have to be manufactured over a very large area. It is important to improve the display uniformity, if one want to make thin CRT displays with large number of gray levels, such as 256 levels for each color.

25 There have been many attempts to improve the display uniformity of thin CRT displays. Some of the methods, such as those described by U. S. Patent No. 5,637,023 and No. 5,610,471 and the references cited therein, try to use better manufacture techniques to improve uniformity of all cold cathodes. And some of the methods, such as

those described by U. S. Patent No. 5,157,309 and No. 5,581,159, try to use better driver electronic designs to improve the electron emission uniformity of all the cathodes. And there is still some other methods, such as U. S. patent No. 5,514,937, which use memory element associated with each electronic driver to compensate the variations among
5 different cathodes. All these methods only provide limited success, and some of these methods are complicated and expensive to implement.

In this document, the applicant present a new method, which the applicant claims to solve the uniformity problem of thin CRT displays once for all. The new method provides almost perfectly uniform display properties for thin CRT displays regardless the
10 inevitable variations of each cathode. The new method disclosed in this document is performed in three steps: First, the emission characteristics of every cathode in the display is measured. Second, the correct driving parameters for each cathode -- used as calibration parameters directly -- are calculated and stored in a calibration memory as a complete look-up table, or the calibration parameters for each cathode are calculated and
15 stored in a calibration memory as a partial look-up table. Third, using the complete look-up tables or using partial look-up tables in combination with additional calculation, the correct driving parameter for any cathode with any luminosity level can be obtained, and the correct driving parameters are used to drive the thin CRT display. For the first step described above, the emission characteristics of all cathodes can be measured by a current
20 detector connected to the anode, or can be measured in a dark chamber by turning on one cathode at a time. For the second step described above, linear approximation or other higher order approximation can be used. For the third step, there are two general embodiments: (1) with embodiment one, all the calculated correct driving parameters are stored in a video memory and driver electronics use these calculated correct driving
25 parameters in the video memory to drive the display; (2) with embodiment two, the desired light intensities are stored in a video memory without any compensation, and using the complete look-up tables or using partial look-up tables in combination with additional calculation, the driver electronics calculate the correct driving parameters by fetching the light intensities from the video memory and use these calculated correct
30 driving parameters to drive the display directly. For both embodiments mentioned above,

when partial look-up tables are used, additional calculations are needed to obtain the correct driving parameters, and these calculations can be performed by the main microprocessor or a dedicated display processor.

5

SUMMARY OF THE INVENTION

It is an object of the invention to provide a method that can provide almost perfectly uniform display properties for thin CRT displays regardless the inevitable variations of each cathode.

Additional advantages and novel features of the invention will be set forth in the description which follows, and in part will become apparent to those skilled in the art upon examination of the following, or may be learned by practice of the invention. The objects and advantages of the invention maybe realized and attained by means of the instrumentality and combinations particularly pointed out in the appended claims.

To achieve the foregoing and other objects and in accordance with the present invention, as described and broadly claimed herein, a measurement method is provided to measure the emission characteristics of every cathode in the display, a calculation method is provided to obtain the calibration parameters of any given cathode by using the measured emission characteristics of the corresponding cathode as the raw data, a calibration memory is provided to store the calibration parameters for any given cathode as a complete look-up table or as a partial look-up table, a method is provided to obtain the correct driving parameters for any given cathode for any give light intensity by using the complete look-up table without additional calculation or by using the partial look-up table with additional calculation, and finally a driver electronics is provided to drive the display with the correct driving parameters. For the measurement method provided to measure the emission characteristics of every cathode in the display, either a current detector connected to the anode or a dark chamber can be used. A thin CRT display driven by the correct driving parameters will provide images free of intensity distortions caused by each cathode's property variations.

BRIEF DESCRIPTION OF THE DRAWINGS

5 The accompany drawings, which are incorporated in and form a part of the invention and, together with the description, serve to explain the principles of the invention. In the drawings, closely related figures have the same number but different alphabetic suffixes.

Figure 1a shows the principle of an FED display.

10 Figure 1b shows a section of the matrix of field emission cold cathodes.

Figure 1c shows the enlarged symbol and the structure of a field emission cold cathode.

Figure 2a shows that, with the same bias voltage, two different cold cathodes give completely different emission current and therefore completely different pixel luminosity.

15 Figure 2b shows that the same bias voltage is applied to two different cold cathodes in the same selected row.

Figure 3 illustrates that the emission characteristics of every cold cathode in a selected row is measured one by one in a scan mode, by measuring the emission current of each cold cathode with a current detector.

20 Figure 4a shows that the emission characteristics of a cold cathode is measured by measuring the emission current of the cold cathode under several selected bias voltages.

Figure 4b shows one can use linear approximation and measured data points to calculate the correct voltage $V(i, j)$ which will provide the desired emission current $I_{target}(i, j)$.

25 Figure 5a shows that a microprocessor use the look-up table in the calibration memory to find out the correct driving voltage, and store the correct driving voltage into the video memory.

Figure 5b shows that the driver electronics fetch uncompensated light intensity from the video memory and use the look-up table in calibration memory to find out the correct driving voltage.

30

Figure 6a shows that a microprocessor use the partial look-up table in the calibration memory in combination with additional calculation to find out the correct driving voltage, and store the correct driving voltage into the video memory.

5 Figure 6b shows that the driver electronics fetch uncompensated light intensity from the video memory and use the partial look-up table in the calibration memory in combination with additional calculation to find out the correct driving voltage.

Figure 7a shows that a microprocessor use the partial look-up table in the calibration memory in combination with linear approximation to calculate the correct driving voltage, and store the correct driving voltage into the video memory.

10 Figure 7b shows that the driver electronics fetch uncompensated light intensity from the video memory and use the partial look-up table in the calibration memory in combination with linear approximation to calculate the correct driving voltage.

Figure 7c shows a specific implementation of a display processor which uses linear approximation to calculate the correct driving voltage.

15 Figure 7d shows that the driver electronics fetch calibration parameters $a(i,j)$ and $b(i,j)$ from the calibration memory and use Fowler-Nordheim model to calculate the correct driving voltage.

20 Figure 8a shows that a cathode, presumably in a row of a cathode matrix, is selected by one voltage source and the emission current is determined by another driving voltage source.

Figure 8b shows that the driving voltage source is turned on for a time period that is determined by the desired luminosity.

Figure 8c shows that the luminosity perceived by an user is linearly proportional to the time period that the cathode is turned on.

25 Figure 9a shows that a cathode, presumably in a row of a cathode matrix, is selected by one voltage source and the emission current is determined by another driving current source.

Figure 9b shows that the driving current source is turned on for a time period that is determined by the desired luminosity.

Figure 9c shows that the luminosity perceived by an user is linearly proportional to the time period that the cathode is turned on.

Figure 10a shows that a cathode, presumably in a row of a cathode matrix, is selected by one voltage source and the emission current is determined by another driving
5 current source.

Figure 10b shows that the driving current source is turned on for a fixed time period, and the desired luminosity is determined by the current level in the driving current sources.

Figure 10c shows that the luminosity perceived by an user is linearly proportional
10 to the current level in the driving current sources.

Figure 11a shows that, for linear emission characteristics, a microprocessor uses the calibration parameter stored in the calibration memory to calculate the correct driving parameters, and store the correct driving parameters into the video memory. In this case, the calibration parameter of a cathode is simply the inverse of the slope of the line
15 representing the luminosity versus the driving-parameter.

Figure 11b shows that, for linear emission characteristics, the driver electronics uses the calibration parameter stored in the calibration memory to calculate the correct driving parameters. In this case, the calibration parameter of a cathode is simply the
inverse of the slope of the line representing the luminosity versus the driving-parameter.

Figure 12 shows that emission characteristics of every cathode is measured by a
20 current detector and by turning on the driving current for only one cathode at a time.

Figure 13 shows that emission characteristics of every cathode is measured by a photo detector in a dark chamber by turning on only one cathode at a time.

DESCRIPTION OF THE INVENTION

Even though the techniques disclosed in present invention can be used to improve the display uniformity of any kind of thin CRT displays with any kind of cold cathodes and with any kinds of driving schemes, but, to simplify the presentation, we first use Spindt Field Emission Display (FED) as an example to demonstrate how present invention is used to improve the display uniformity of this most common type of thin CRT displays. Then, we will extend the technique to other kinds of thin CRT displays using other kinds of cold cathodes, such as SCE cathodes, MIS cathodes and diamond cathodes.

FED technology have been disclosed in many patent documents, and the basic patents describing the technology include US Patents 3,500,102, 4,857,799 and 4,763,187, which are included hereinafter by reference. The basic principle of a FED is quite similar to that of a CRT display--with the modification that the single electron gun for each color in CRT displays is replaced by a matrix of individually addressable filed emission cold cathodes, with one cathode for each pixel.

As illustrated in Fig. 1a and 1b, a FED includes a transparent anode plate 1, a matrix of individually addressable filed emission cold cathodes 2 fixed on a back plate 3 (not shown in Fig. 1a and 1b), and a vacuum space 4 between the anode and the cathode matrix 2. Each of the filed emission cold cathodes is represented by a special symbol, and one of the filed emission cathode 10 with an enlarged symbol is illustrated in Fig. 1c. The side of the anode plate 1 facing the cathode matrix are coated phosphors 5, and the anode plate 1 is kept at a potential typically around 500 volts relative to the common ground. A driver array 6 is connected to a set of driving lines 7, and each driving line 7' is connected to one end of a cathode array 7'' in the cathode matrix 2. A second driver array 8 is connected to a second set of driving lines 9, and each driving line 9' is connected to the other end of a cathode array 9'' in the cathode matrix 2. One row (or column) of cathodes 7'' is turned on at one time by turning on one driver 6' in the driver array 6, and the number of electrons emitted from each of cathodes in that row (or column) is controlled by the different voltages applied to the different drivers in the

second driver array 8. Each row (or column) of cathode is turned on one by one by scanning the on-state driver 6' in the driver array 6. The electrons emitted from the cathodes are accelerated towards the anode, and impact the phosphors 5 on the anode plate 1; the phosphors 5 excited by the impact electrons will emit light with the light intensity determined by the number of electrons emitted from the corresponding filed emission cathodes.

To understand in detail how the number of electrons emitted from each cathodes is controlled, it is necessary to understand the principle of a filed emission cold cathode. As shown in Fig. 1c, a filed emission cold cathode 10 has a base electrode 12. A matrix of metal or semiconductor sharp tips 14 are constructed on top of the base electrode 12. Each tip 14' in the tip matrix 14 is covered with a gate 16'. All the individual gate 16' connected together form the second electrode 16 of the cold cathode. As shown in Fig. 1c, the gate 16' covers the tip 14' with a hole 15' lined up with the tip 14' in the middle. The size of the tip 14' is usually on the order of sub-microns, and the vertical distance between the tip 14' and the gate 16' is usually on the order of microns. When a positive voltage on the order of tens of volts is applied to the gate electrode, the electrons in the tip will be extracted out by filed emission. The emitted electrons shoot out into the vacuum through the center hole 15' on the gate 16'. The number of electrons emitted into the vacuum is the function of the voltage difference applied between the base electrode and the gate electrode. When the cathodes in the cathode array 7'' is selected for emission, the on-state driver 6' will set the bias voltage, on each of the cathodes in that cathode array 7'', close to the threshold voltage V_{th} . The amount of electrons emitted from each individual cathode in the cathode array 7'' is determined by the voltage on the corresponding driving lines driven by the second array of drivers 8. By controlling the amount of electrons emitted from each individual cathode in the cathode array 7'', a line of image is displayed on the anode plate, and by scanning quickly the on-state driver 6' one by one, a complete image is displayed on the anode plate.

It is noted that in the above described filed emission display, the on-state driver can either connected to the base electrode of the cathodes or the gate electrode of the

cathodes, and correspondingly, the second driver arrays can be connected either to the gate electrode of the cathodes or the base electrode of the cathodes.

One of the biggest problem with the previously described voltage driven FED is that it is very difficult to achieve the necessary display uniformity with present Spindt cold cathodes technology. Different cathode driven methods have been invented to circumvent the non-uniformity problem. Some of these cathode driven methods, such as current-driving method described in U. S. Patent No. 5,157,309, provide substantial improvement in display uniformity. But, the current-driving method still have display non-uniformity problem, and more methods are conceived to solve the non-uniformity problem of current-driving method, such as the methods described in U.S. No. 5,578,906 and 5,514,937. However, with the methods to be disclosed in the following, nearly perfect display uniformity can be achieved for any kinds of driving schemes. To illustrate the effectiveness of present invention, in the following, we will first demonstrate that even the inferior voltage-driving method can achieve perfect display uniformity by using present disclosed invention. The embodiment of using present invention with current-driving and other superior cathode driven methods will be disclosed following the discussion on the voltage-driving method.

The display uniformity problem is due to the variations of emission characteristics of all the cathodes in the cathode matrix. Such variations are inevitable, because very large number of cold cathodes are manufactured. Figure 2a shows that, with the same bias voltage, two different cold cathodes give completely different emission current and therefore completely different pixel luminosity, where, V_{on} is the voltage applied by the on-state driver to select a particular row into emission mode, and V_L is the same luminosity voltage applied to cathode A and cathode B as indicated in Fig. 2b. As shown in Fig. 2a, even though the total voltage applied to the two cathodes (A and B) is the same $V_{on} + V_L$, the emission current from the two cathodes are different (they are I_{eA} and I_{eB} respectively for cathode A and B), because the emission characteristics (or the curve defined by emission current I_e versus driving-voltage V) of the two cathodes are different. These difference in emission current can be compensated, however, if one knows the emission characteristics of the corresponding cold cathodes.

The very basic idea of present invention can be summarized by operating thin CRT displays in three steps. First, the emission characteristics of every cathode in the display is measured. Second, the correct driving voltages for each cathode used as calibration parameters directly are calculated and stored in a calibration memory as a complete look-up table -- which is called method one, or the calibration parameters for each cathode are determined and stored in a calibration memory as a partial look-up table -- which is called method two. Third, when a certain luminosity in a certain pixel is to be displayed, the microprocessor will use the a complete look-up table in the calibration memory to find the correct driving voltage for that luminosity, or, the microprocessor will use the partial look-up table in the calibration memory in combination with additional calculation to find the correct driving voltage for that luminosity, and the correct driving voltage is used by the driver electronics to drive the display.

Figure 3 shows how the emission characteristics of all cathodes are measured by a current detector 50 connected between the anode 1 and the anode voltage 30. Like in the conventional display mode, the gate electrodes (or alternatively the emitter electrodes) of only one row is biased to the on-voltage V_{on} . All the rows are scanned one by one. But, in contrast to the display mode where luminosity voltage V_L of all cathodes in that turned-on row are applied simultaneously, in the calibration mode, only one cathode is applied with luminosity voltage V_L and the rest of the cathodes in that row are turned off, which is shown in Fig. 3. By measuring the emission current corresponding to several different values of luminosity voltage, the emission characteristics of that one cathode is measured and stored in a memory for further processing. The number of points on the emission characteristics need to be measured depend on the non-linearity of the emission curve and the required display resolution (e.g. 4 bit or 8 bit). If the emission curve is close to linear, which is the case for some of the cathode driving methods to be discussed later (e.g. current-driving method), only one measurement is necessary for each cathode. As shown in Fig. 3, the emission characteristics of all the cathodes in that selected row can be measured one at a time by scanning all the cathodes in that row. After all the cathodes in that row are measured, that row will be turned off and next row will be turned on, and the all the cathodes in the newly selected row will be measured one by one. By

scanning all the rows in the matrix, the emission characteristics of all the cathodes in the matrix can be measured. As shown in Fig. 4a, the emission characteristics of a cathode at row i and column j , is characterized by a set of numbers, $I_{e1}(i, j)$ for luminosity voltage V_{L1} , $I_{e2}(i, j)$ for luminosity voltage V_{L2} , $I_{e3}(i, j)$ for luminosity voltage V_{L3} , ..., and $I_{eH}(i, j)$ for luminosity voltage V_{LH} , where H is the number of points on the emission curve measured for each cathode. These numbers are stored in a memory for further processing. If the number of row is N and the number of column is M , then a total of $N*M*H$ numbers are stored in the memory.

If there is no cathode degrading effect, the above calibration process need to be performed only once. If there are cathode degrading effect, above calibration process need to be performed again at a later time to correct the cathode degrading effect.

After the measurement of the emission curves of all cathodes, the correct driving voltage for any desired emission current for any cathodes can be calculated. For example, for cathode (i, j) at i 'th row and j 'th column, to calculate a desired emission current $I_{target}(i, j)$, one first compare the desired emission current $I_{target}(i, j)$ with all the measured emission current $I_{e1}(i, j)$, $I_{e2}(i, j)$, $I_{e3}(i, j)$ and $I_{eH}(i, j)$. Suppose that $I_{target}(i, j)$ happen to be between $I_{e2}(i, j)$ and $I_{e3}(i, j)$, as shown in Fig. 4b, then, one can simply use linear approximation to calculate the correct driving voltage $V(i, j)$, which is given by

$$V(i, j) = \frac{V_{L3}[I_{target}(i, j) - I_{e2}(i, j)] + V_{L2}[I_{e3}(i, j) - I_{target}(i, j)]}{I_{e3}(i, j) - I_{e2}(i, j)}$$

Or, to increase the accuracy in calculating $V(i, j)$, one can use parabola approximation or other higher order approximations. For polynomial approximation with order H , the correct driving voltage $V(i, j)$ is given by

$$V(i, j) = \frac{[I_{e2}(i, j) - I_{target}(i, j)][I_{e3}(i, j) - I_{target}(i, j)] \cdots [I_{eH}(i, j) - I_{target}(i, j)]}{[I_{e2}(i, j) - I_{e1}(i, j)][I_{e3}(i, j) - I_{e1}(i, j)] \cdots [I_{eH}(i, j) - I_{e1}(i, j)]} V_{L1}(i, j) \\ + \frac{[I_{e1}(i, j) - I_{target}(i, j)][I_{e3}(i, j) - I_{target}(i, j)] \cdots [I_{eH}(i, j) - I_{target}(i, j)]}{[I_{e1}(i, j) - I_{e2}(i, j)][I_{e3}(i, j) - I_{e2}(i, j)] \cdots [I_{eH}(i, j) - I_{e2}(i, j)]} V_{L2}(i, j) \\ + \cdots$$

One can even use more complicated algorithm, such as, use least square fit in combination with device models to calculate the correct driving voltage $V(i, j)$ which can achieve the desired intensity $I_{\text{target}}(i, j)$. For example, one can use Fowler-Nordheim model, $I = aV^2 \exp(-b / V)$, and first use least square fit to determine the model parameters a and b by fitting the model curve with all measured data on the emission curve, then, one can calculate the correct driving voltage $V(i, j)$ which can achieve the desired intensity $I_{\text{target}}(i, j)$ by finding the voltage $V(i, j)$ for equation

$$I_{\text{target}}(i, j) - a(i, j)V^2(i, j)e^{-b(i, j)/V(i, j)} = 0, \text{ where } a(i, j) \text{ and } b(i, j) \text{ are calibration parameters which are already known from curve fitting.}$$

There are generally two methods of using the measured emission curve to provide a perfectly uniform display. With method one, for every cathode in the display, the correct driving voltages for all gray levels are calculated; these correct driving voltages are used as calibration parameters directly and stored as complete look-up tables in a calibration memory for future use; and one will use the complete look-up table to find the correct driving voltages without the need to perform additional calculation. With method two, for every cathode in the display, calibration parameters are calculated and stored as partial look-up tables in a calibration memory for future use; and one will use the partial look-up table in combination with some additional calculation in real time to find the correct driving voltages. As for the calibration parameters, the correct driving voltages for selected number of gray levels can be calculated and used as the calibration parameters, or other model-dependent parameters can be calculated and used as the calibration parameters.

If there is no cathode degrading effect, the above described look-up tables need to be calculated only once, and these look-up tables can be stored in a permanent memory, such as ROM, or hard disk. If there are cathode degrading effect, the above described look-up tables need to be calculated again at a later time to correct the cathode degrading effect. If the look-up tables are stored in a relatively fast ROM, the ROM can be used directly as the calibration memory. If the look-up tables are stored in a slower permanent

memory, say, hard disk, the look-up tables will have to be loaded into a faster RAM from the permanent memory, and use this RAM as the calibration memory.

Figure 5a shows in detail the method one mentioned above. With method one, for every cathode in the display, the correct driving voltages-- $V_1(i, j)$, $V_2(i, j)$, $V_3(i, j)$, ..., and $V_k(i, j)$ --for all gray levels with corresponding desired emission current -- I_1 , I_2 , I_3 , ..., and I_k -- are calculated by using linear approximation or other previously described methods. More specifically, for 8 gray levels, 8 voltages are calculated for each cathode, and for 256 gray levels, 256 voltages are calculated. These calculated correct driving voltages are used as calibration parameters directly and stored in a calibration memory 70. With a conventional display, if a computer want a pixel to display certain intensity, it will write the intensity word (which is a byte for 8 bit gray level) of the pixel to a location in the video memory 80, and the driver electronics will use the intensity words in video memory 80 to drive the display. With present newly invented display, however, if a computer want a pixel to display certain desired intensity, it will first use the look-up table of the cathode associated with the corresponding pixel in calibration memory 70 to find out the correct driving voltage for that desired intensity, write this correct driving voltage to video memory 80, and the driver electronics will use the correct driving voltages in video memory 80 to drive the field emission display. Alternatively, as shown in Fig. 5b, the computer can still write the uncompensated intensity word to video memory 80, but, the driver electronics itself will use the look-up tables in calibration memory 70 to find out the correct driving voltage for any gray level of any cathode, and use this correct driving voltage to drive the field emission display.

Above described method one is relatively easy to implement, but, if a display has large number of cathodes and each cathode has large number of gray levels, the amount of calibration memory required can be quite large. For example, for a 256-gray-level display with one million pixels, one need to store 256 million numbers. If each correct driving voltage is stored as a byte to represent the absolute number, then, 256 Megabyte calibration memory is needed. To reduce the memory requirement, one can instead store relative numbers in calibration memory 70. For example, one can store relative number $\Delta V_k(i, j) = V_k(i, j) - \bar{V}_k$ into calibration memory 70, where $\bar{V}_k = \sum V_k(i, j)$ is

the average driving voltage for gray level k averaged over all cathodes, and $1 \leq k \leq K$. If the variations among different cathodes are small, one can use a smaller number of bit (such as 4 bit) to represent $\Delta V_k(i, j)$ even one need 8 bit to represent $V_k(i, j)$. Another way to reduce the calibration memory requirement, which is the method two mentioned previously, is to use partial look-up tables, instead of complete look-up tables.

Figure 6a and 6b show in detail the method two mentioned previously. With method two, for every cathode in the display, the correct driving voltages -- $V_1(i, j)$, $V_2(i, j)$, $V_3(i, j)$, ..., and $V_K(i, j)$ -- for selected number of gray levels with corresponding desired emission current -- I_1 , I_2 , I_3 , ..., and I_K -- are calculated and used as calibration parameters. These calibration parameters are stored as partial look-up tables in a calibration memory 70 for future use. The driver electronics will use the partial look-up tables in combination with some additional calculation in real time to find the correct driving voltages. Where the number of gray levels K selected are smaller than the number of total gray levels. As for the issue on how to chose I_1 , I_2 , I_3 , ..., and I_K , it may be chosen based on the non-linearity of the emission curve or just chosen for convenience, such as for a four point calibration, one simply may chose $I_1 = (1/4)I_0$, $I_2 = (2/4)I_0$, $I_3 = (3/4)I_0$, and $I_4 = I_0$, where I_0 is the emission current corresponding to the maximum light intensity.

After the calibration parameters are calculated and stored as partial look-up tables in calibration memory 70, the next step is to use the partial look-up tables to calculate the correct driver voltages to provide nearly perfect display uniformity for a FED.

With a conventional display, if a computer want a pixel to display certain intensity, it will write the intensity word (which is a byte for 8 bit gray level) of the pixel to a location in a video memory, and the driver electronics will use the intensity words in the video memory to drive the display. With present newly invented display, however, if a computer want a pixel to display certain desired intensity, it will first fetch the related calibration parameters from the corresponding partial look-up table from calibration memory 70, as shown in Fig. 6a, then, use these calibration parameters along with the intensity word to calculate the correct driving voltage that can achieve the desired intensity for that pixel, write this correct driving voltage to video memory 80, and the

driver electronics will use the correct driving voltages in video memory 80 to drive the field emission display. Alternatively, as shown in Fig. 6b, the computer can still write the uncompensated intensity word to video memory 80, but, the driver electronics itself will use the partial look-up table in calibration memory 70 in combination with some
 5 calculations to find out the correct driving voltage for any gray level of any cathode, and use this correct driving voltage to drive the field emission display directly. In both of the above two alternatives, some calculations are required to obtain the correct driving voltage; these calculation can be performed with a microprocessor 60, which can be the main microprocessor or preferably a dedicated display processor. In the following,
 10 several algorithms for performing these calculations are described, and for linear approximation, a specific design of display processor 60 is described.

Figure 7a illustrates a specific implementations of Fig. 6a based on linear approximations, and Fig. 7b illustrates that of Fig. 6b. In Fig. 7a or 7b, the microprocessor 60 or driver electronics 90 first compare desired intensity $I(i, j)$ —which is
 15 the desired emission current in this case—with the set of intensity levels (I_1, I_2, I_3, \dots , and I_K) which have pre-calculated driving voltages stored in calibration memory 70, the microprocessor find the two numbers (among I_1, I_2, I_3, \dots , and I_K) which are most close to the desired intensity $I(i, j)$; , the microprocessor 60 or driver electronics 90 will then fetch the driving voltages corresponding to these two numbers from calibration memory
 20 70 and use liner approximation to calculate the driving voltage $V(i, j)$ which can achieve the desired intensity $I(i, j)$; finally, the calculated driving voltage $V(i, j)$ is stored in video memory or used by driver electronics to driver the display directly. Take an example of how $V(i, j)$ is calculated , if $I_2 < I(i, j) < I_3$, then

$$V(i, j) = \frac{V_3(i, j)[I(i, j) - I_2] + V_2(i, j)[I_3 - I(i, j)]}{I_3 - I_2}.$$

25 In fact to simplify the above calculation and speed up the calculation in real time, one can chose $\Delta I = I_2 - I_1 = I_3 - I_2 = \dots = I_K - I_{K-1}$, and rather than store $V_k(i, j)$ (with $k = 1, 2, \dots, K$) in the calibration memory, one can store $v_k(i, j) = V_k(i, j)/\Delta I$ (with $k = 1, 2, \dots, K$) in calibration memory 70. The microprocessor 60 or driver electronics 90 then use

$v_k(i, j)$ to calculate the desired voltage

$V(i, j) = v_{k+1}(i, j)[I(i, j) - I_k] + v_k(i, j)[I_{k+1} - I(i, j)]$, where $I_k < I(i, j) < I_{k+1}$. The

microprocessor used to perform the above calculations can be the main microprocessor or a dedicated display processor. Figure 7c illustrates a specific design of display processor

5 60 based on above linear approximation by using hardware gate elements.

To minimize the calibration memory requirement one can store a normalized variation of $v_k(i, j)$. The normalized variation $\alpha_k(i, j)$ is defined by

$v_k(i, j) = \bar{v}_k[1 + S\alpha_k(i, j)]$, where S is a scaling factor which depend on the variations of all the $v_k(i, j)$, and \bar{v}_k is the average of $v_k(i, j)$ over all cathodes

$$10 \quad \bar{v}_k = \frac{1}{N * M} \sum_{i=1, j=1}^{N, M} v_k(i, j).$$

The average $\bar{v}_1, \bar{v}_2, \bar{v}_3$..and \bar{v}_K , and the scaling factor S are also stored in a memory, and these numbers can be loaded into the microprocessor to perform the calculation. The design of a dedicated display processor by using the normalized variation $\alpha_k(i, j)$ is straight forward for the people skilled in the art, and will not be discussed further here.

15 To demonstrate the feasibility of the current invention, we now estimate the amount of the calibration memory that is required and the processing power of the display processor that is required. Assume the display have 1600 x 1200 pixels and in each pixel one cathode is used to create three colors (the color is created by changing the anode voltage on the color segments), and assume four calibration points are stored for each

20 emission curve, if one byte is used to store each normalized variation $\alpha_k(i, j)$, then, the total memory required is $1600 \times 1200 \times 4 = 7,680,000$ byte. If the display is refreshed 60 times in a second, then, $1600 \times 1200 \times 60 = 115,200,000$ calculations need to be performed in a second. The sample architecture of the display processor in Fig.7c indicates that simple pipe line design can be used, and with the pipeline design one

25 calculation can be performed with every clock cycle. Therefore, a display processor running at 115 MHz is powerful enough for the current invention. With more advanced design, in which more than one instructions are performed for each clock cycle, a microprocessor running at a clock rate with a fraction of 115MHz is powerful enough for the present application.

In Fig. 7a or 7b, the microprocessor 60 or the driver electronics 90 first compare desired intensity $I(i, j)$ —which is the desired emission current in this case—with the set of intensity levels ($I_1, I_2, I_3, \dots, \text{and } I_K$) which have pre-calculated driving voltage stored in calibration memory 70, the microprocessor 60 or the driver electronics 90 find the two numbers (among $I_1, I_2, I_3, \dots, \text{and } I_K$) which are most close to the desired intensity $I(i, j)$; the microprocessor 60 or the driver electronics 90 will then fetch the driving voltages corresponding to these two numbers from calibration memory 70 and use linear approximation to calculate the driving voltage $V(i, j)$ which can achieve the desired intensity $I(i, j)$. In fact, one can also use polynomial approximation to calculate the driving voltage $V(i, j)$ which can achieve the desired intensity $I(i, j)$. For example,

$$V(i, j) = \frac{(I_2 - I)(I_3 - I) \cdots (I_K - I)}{(I_2 - I_1)(I_3 - I_1) \cdots (I_K - I_1)} V_1(i, j) + \frac{(I_1 - I)(I_3 - I) \cdots (I_K - I)}{(I_1 - I_2)(I_3 - I_2) \cdots (I_K - I_2)} V_2(i, j) + \dots$$

One can even use more complicated algorithm, such as, least square fit to calculate the driving voltage $V(i, j)$ which can achieve the desired intensity $I(i, j)$. Of course, the more complicated the algorithm, the more it is required for the processing power of the microprocessor 60 or the driver electronics 90. One need to make a compromise between the processing power and the amount of calibration memory required. With enough calibration memory, simple linear approximation algorithm can already provide the satisfactory results.

If Fowler-Nordheim model is used, $I = aV^2 \exp(-b/V)$, and suppose a and b are used as calibration parameters, the correct driving voltage $V(i, j)$ which can achieve the desired intensity $I(i, j)$ then can be calculated based on equation

$I(i, j) - a(i, j)V^2(i, j)e^{-b(i, j)/V(i, j)} = 0$, where $a(i, j)$ and $b(i, j)$ are fetched from calibration memory 70. Figure 7d shows an example that the calculation is performed with a feedback electronics. In Fig. 7d, the desired intensity $I(i, j)$ is stored in video memory 80, a driver electronics 90 calculate the correct driving voltage by fetching $I(i, j)$ from video memory 80 and calibration parameters-- $a(i, j)$ and $b(i, j)$ --from calibration memory 70, then, driver electronics 90 use the correct driving voltage to drive the display.

In the above, we show that even the inferior voltage-driving method can be improved with present disclosed method to provide nearly perfect display uniformity. The drawback of the voltage driving method is now turn to be that larger amount of calibration memory have to be used, due to that fact that several calibration parameters have to be stored. Some of the other driving methods, however, can be improved to provide the nearly perfect uniformity by storing only one calibration parameter. In all these kinds of methods, the gray level is roughly proportional to the driving parameter. One example is shown in Fig. 8a, 8b and 8c, which is called voltage-time method for facilitating discussion. Another example is shown in Fig. 9a, 9b and 9c, which we is called current-time method. And the third example is shown in Fig. 10a, 10b and 10c, which is called current-driving method.

In the voltage-time method, as shown in Fig. 8a-8c, a voltage V_{on} is used to select one row of cold cathodes in a matrix to emit electrons, and for each cold cathode in that selected row, another voltage source V_L is applied to make the cathode to emit electrons. Of course, the number of voltage sources V_L is equal to the number of cold cathodes in each row. The amplitude of voltage V_L , when applied to a cathode, is always the same constant voltage V_0 , but the time interval t_L during which V_L is applied will determine the luminosity L perceived by a user. And in fact, luminosity L is linearly proportional to t_L , as shown in Fig. 8c. Because the manufacture variations, different cathode in the cathodes matrix may have different slope k in the L verses t_L curve. And the emission characteristics of a cathode can be determined by a single parameter k , which can be measured by a single measurement.

In the current-time method, as shown in Fig. 9a-9c, a voltage V_{on} is used to select one row of cold cathodes in a matrix to emit electrons, and for each cold cathode in that selected row, another current source I_L is applied to make the cathode to emit electrons. Of course, the number of current sources I_L is equal to the number of cold cathodes in each row. The amplitude of current I_L , when applied to a cathode, is always the same constant current I_0 , but the time interval t_L during which I_L is applied will determine the luminosity L perceived by a user. And in fact, luminosity L is linearly proportional

to t_L , as shown in Fig. 9c. Because the manufacture variations, different cathode in the cathodes matrix may have different slope k in the L versus t_L curve. And the emission characteristics of a cathode can be determined by a single parameter k , which can be measured by a single measurement.

5 In the current-driving method, as shown in Fig. 10a-10c, a voltage V_{on} is used to select one row of cold cathodes in a matrix to emit electrons, and for each cold cathode in that selected row, another current source I_L is applied to make the cathode to emit electrons. Of course, the number of current sources I_L is equal to the number of cold cathodes in each row. The time interval t_L during which I_L is applied is always the
10 same. The amplitude of the current I_L applied to a cathode will determine the luminosity L perceived by an user. And in fact, luminosity L is linearly proportional to I_L , as shown in Fig. 10c. Because the manufacture variations, different cathode in the cathode matrix may have different slope k in the L versus I_L curve. And the emission characteristics of a cathode can be determined by a single parameter k , which can be
15 measured by a single measurement.

Once the emission characteristics of each cathode in the cathode matrix is measured, and the calibration parameter (which is related to the slope of the emission characteristics) of each cathode is stored in a calibration memory, nearly perfect display uniformity can be obtained by a simple calculation, which is just a single step of
20 multiplication. We may use $L = kx$ to generally represent L versus t_L or L versus I_L , where x is the driving parameter (t_L or I_L). The driving parameter x at cathode (i, j) can be determined by the desired luminosity $L(i, j)$ and the slope $k(i, j)$. If $\beta(i, j) = 1 / k(i, j)$ is stored in the calibration memory as shown in Fig. 11a or Fig. 11b, the driving parameter $x(i, j)$ can be obtained from a simple multiplication,
25 $x(i, j) = \beta(i, j)L(i, j)$. In Fig. 11a, a microprocessor 60 will first calculate the correct driving parameter $x(i, j)$ which provides the desired luminosity $L(i, j)$, then store the correct driving parameter $x(i, j)$ in video memory 80, and the driver electronics will use the correct driving parameter $x(i, j)$ in video memory 80 to drive the display. In Fig.

11b, the uncompensated luminosity $L(i, j)$ is stored in video memory 80, the driver electronics 90 will calculate the correct driving parameter $x(i, j)$ which provides the desired luminosity $L(i, j)$ by fetching $L(i, j)$ from video memory 80 and $\beta(i, j)$ from calibration memory 70, and driver electronics 90 will use the correct driving parameter $x(i, j)$ to drive the display directly. Again, to minimize the calibration memory requirement, instead of storing $\beta(i, j)$ in the calibration memory, one can store $\gamma(i, j)$, defined by $\beta(i, j) = \beta_0[1 + S\gamma(i, j)]$, where β_0 is the average of $\beta(i, j)$ over all cathodes and S is a scaling factor. And microprocessor 60 or driver electronics 90 need to perform a slightly more complicated calculation $x(i, j) = \beta_0[1 + S\gamma(i, j)]L(i, j)$. Microprocessor 60 can be the main microprocessor or a dedicated microprocessor.

The embodiment shown in Fig. 11a when applied to the current-driving method is the most preferred embodiment among all the embodiments and methods disclosed in the present disclosure.

The emission characteristics of the above discussed three methods-- voltage-time method, current-time method and current-driving -- is linear only in the ideal situation. Other factors, such as the capacitance of the cathode, can make the emission characteristics deviate from the ideal linear relationship.

Taking current-driving method as an example, because the capacitor of a cathode has to be charged up before electron emission occurs and the rate of charging up the capacitor depends on the driving current, thus, the emission characteristics will not be perfectly linear. And because the rate of charging up the capacitor of a cathode also depend on the value of the capacitor, which varies from cathode to cathode due to the inevitable manufacture variations, thus, the emission characteristics of a cathode will not only be non-linear but also varies from one cathode to another cathode. Another reason that the emission characteristics of a cathode varies from one cathode to another cathode is that different cathode have different emission coefficient (or the ratio of the emission current to the driving current). There has been some attempt to solve this problem associated with current-driving method, such as the method described in U.S. patent No. 5,514,937 and 5,578,906. These methods have only provided limited success. Based on the teaching in the present disclosure, it is clear that the display non-uniformity problem

can be easily solved by present disclosed method. Repeating a summary of the present disclosed method: first, the emission characteristics of every cathode is measured; then, correct driving parameters of every cathode are stored as a complete look-up table in a calibration memory or the calibration parameters of every cathode are stored as a partial look-up table in a calibration memory; finally, the correct driving parameters of every cathode are obtained from the complete look-up table without additional calculation, or obtained from the partial look-up table with additional calculation, and correct driving parameters are used to drive the display. When the emission characteristics of a cathode in current-driving method is no longer linear, more than one point on the emission characteristics curve have to be measured.

We now turn to the discussion on how to measure the emission characteristics of a cathode. In order to measure the emission characteristics of all cathodes in the cathode matrices of a thin CRT display, one row of cathodes is selected at one time. When that particular row is selected, the emission characteristics of one individual cathode in that row is measured one by one, by measuring one cathode at a time and by setting all the rest of the cathodes in that row to non-emitting state. When measuring the emission characteristics of one cathode, one point on the emission characteristics curve is measured if the curve is linear, and several points on the emission characteristics curve are measured if the curve is non-linear. In the case that the emission characteristics curve is non-linear, the number of points needed to be measured depend on the non-linearity of the curve, the variations of the curve among different cathodes, and the number of gray levels needed to be achieved with the thin CRT display.

In the previous discussion of voltage-driving method, the emission characteristics of a cathode is measured by measuring the curve of emission current versus driving voltage. Similarly, with current-driving method, the emission characteristics of a cathode can be measured by measuring the curve of emission current versus driving current, as shown in Fig. 12. However, with voltage-time and current-time methods, one needs to measure the emission current integrated over the time period during which the driving voltage or current is turned on, and the emission current integrated over that time period is actually the total charge that is emitted onto the anode. Because the total charge

that is emitted onto the anode by a particular cathode is directly proportional the
luminosity perceived by an user, therefore, the curve of the total charge versus the driving
parameter (which can be voltage, current or time) is a faithful representation of the curve
of the luminosity versus the driving parameter. Thus, with voltage-time and current-time
5 methods, the emission characteristics of a cathode is measured by measuring the curve of
the total emitted charge versus the time period during which the driving voltage or current
is turned on. And in fact, with voltage-driving method, the emission characteristics of a
cathode can also be measured by measuring the curve of the total emitted charge versus
the driving voltage, and with current-driving method, the emission characteristics of a
10 cathode can be measured by measuring the curve of the total emitted charge versus the
driving current as well.

To measure the total charge that is emitted onto the anode by a cathode, one can
measure the emission current and integrate the emission current with an integrator over
the time period that is allocated for that cathode to emit. Generally, that time period can
15 be a constant to simplify the design. With voltage-driving and current-driving methods,
that time period is already a constant. With voltage-time and current-time methods, the
integration time can be the maximum time period that a cathode can be turned on. For
gray level less than the maximum luminosity, the actual time period that a cathode is
turned on is of course smaller than the maximum time period that a cathode can be turned
20 on, and the integration over the maximum time period is the same as the integration over
the actual time period. After measuring the total charge emitted (or the emission current
integrated over time), one store the measured value of the total charge into a memory for
further calculation. And again, the curve of the total charge versus the driving parameter
is a faithful representation of the emission characteristics of a cathode.

25 Another way of measuring of the emission characteristics of every cathode in a
display is to perform all the measurement in a dark chamber. As shown in Fig. 13, for a
particular thin CRT 100, to obtain a light-intensity versus driving-parameter table for a
pixel 101, be it complete or partial, one can put thin CRT 100 in a dark chamber 200 and
use a photo detector 210 to measure the light intensities with a set of driving parameters
30 for that pixel 101 while all the rest of pixels are completely turned off. And, one need to

repeat the same procedure one pixel at a time, until the light-intensity versus driving-parameter tables of all pixels in the thin CRT are measured. These steps of measuring display characteristics of each pixel in a thin CRT can be performed in the factory before the thin CRT is shipped. The measurement may need to be performed with different
5 temperatures in the case that the emission characteristics of each pixel is temperature dependent. Then, these measured emission characteristics are used to obtain the complete or partial look-up tables. Finally, the complete or partial look-up tables are stored in a permanent memory for future use.

In present disclosed method, the process of compensating non-uniformity of a thin
10 CRT display consists of the stage of measuring the emission characteristics of every cathode, the stage of determining the calibration parameters from the measured emission characteristics, and the stage of using the calibration parameters of every cathode to calculate the correct driving parameters which will give desired luminosity levels.

For the stage of measuring the emission characteristics of every cathodes, one can
15 measure those emission characteristics only once, calculate the correct driving parameters and store them as complete look-up tables in a permanent memory, or calculate the calibration parameters and store them as partial look-up tables in a permanent memory. Later on, one can always use those stored complete or partial look-up tables to obtain the correct driving parameters, provided the emission characteristics of those cathodes do not
20 change over time. If the emission characteristics of those cathodes changes or degrade over time, one has to measure the emission characteristics periodically, say, once every month, and how often that need to be re-measured depend on the rate of changes of those emission characteristics. If the users don't mind to wait for a while (say a few seconds to a few minutes, depend on the number of points that need to be measured), then, one don't
25 have to use permanent storage, since one can simply measure those characteristics at the time when the display power is turned on and store those numbers in a RAM.

For the stage of using the calibration parameters of every cathode to calculate the correct driving parameters, one can use specially designed display processor to perform the calculation or use a software programmed general purpose microprocessor, which can
30 even be the main CPU. As for the selecting of the calibration parameters, we listed

several examples in the above presentation, such as, using the correct driving parameters for all gray levels of a cathode as the calibration parameters, using the correct driving parameters for selected gray levels of a cathode as the calibration parameters, using the fitting parameters of the measured emission characteristics based on a device model as the calibration parameters, and using the slope of the measured emission characteristics as the calibration parameters. Based on above teaching, people skilled in the art can chose other kinds of parameters as the calibration parameters. In fact, without considering the requirement of the calibration memory or the processing power, one can simply chose the measured emission characteristics of a cathode directly as the calibration parameters, store that measured emission characteristics directly into the calibration memory, and use the measured emission characteristics from the calibration memory to calculate the correct driving parameters for that cathode.

In the above presentation of the present invention, we have used field emission display as an example. In fact, as pointed out in the introduction, present invention is applicable to any kinds of thin CRT displays based on matrix of cold cathodes, in any kind of driving arrangement, provided that any one of the individual cold cathode can be addressed independently. One example is Canon's surface conducting electron display (SED). There are several designs and driving schemes of the surface conducting electron display, and present invention of improving display uniformity is applicable to all those designs and driving schemes. In particular, present invention is applicable to all the disclosed designs and driving schemes disclosed in U.S. patent No. 5,627,436 and the references cited therein.

For any kinds of thin CRT displays based on matrix of cold cathodes of any kinds, in any kind of driving arrangement. If any one of the individual cold cathode in the matrix can be addressed independently, then, the emission characteristics of any cold cathode can be measured independently. Once the measured emission characteristics of all cold cathodes are measured, the correct driving parameters of all cathodes can be calculated and stored as complete look-up tables, or the calibration parameters of all cathodes can be calculated and stored as partial look-up tables in a calibration memory. A microprocessor can use the stored complete or partial look-up tables to obtain nearly

perfect display uniformity based on the algorithm and methods disclosed in the present invention. The emission characteristics of a cathode in the cathode matrix can be measured with a current detector connected to the anode. The emission characteristics of a cathode can be measured by using the current detector to measure the total emitted charges (or simply emission current in some cases), for one or several values of driving parameters –such as voltage, current or time. The emission characteristics of a cathode in the cathode matrix can also be measured in a dark chamber.

In the above, present invention has been applied to field emission displays and very briefly to Canon's surface conducting emission display, the more detailed discussion on how to use present disclosed method in all other kinds of thin CRT displays will not be repeated here, and it is apparent for the people skilled in the art to apply present disclosed method to any kinds thin CRT displays with any kind of cold cathodes based on any kind of driving schemes. The kind of cold cathodes mentioned above include, but not limited to, Spindt field emission cathodes, Surface Conducting Electron (SCE) cathodes, MIS cathodes, Silicon avalanche cathodes, diamond cathodes, MIM cathodes, pn junction cathodes and Schottky junction cathodes. The kind of driving schemes mentioned above include, but not limited to, any amplitude modulation schemes with examples of voltage-driving method or current-driving method, any pulse width modulation schemes with examples of voltage-time or current-time method, and any combination schemes of amplitude modulation and pulse width modulation with which the luminosity of a pixel is changed by changing both the amplitude and the pulse width of the driving parameter such as voltage or current.

The forgoing description of selected embodiments and applications has been presented for purpose of illustration. It is not intended to be exhaustive or to limit the invention to the precise form described, and obviously many modifications and variations are possible in the light of the above teaching. The embodiments and applications described above was chosen in order to explain most clearly the principles of the invention and its practical application thereby to enable others in the art to utilize most effectively the invention in various embodiments and with various modifications as are suited to the particular use contemplated. Accordingly, the scope of the invention should

be determined not by the embodiments illustrated, but by the appended claims and their legal equivalents.

I claim:

- 1 1. A method for improving the display uniformity of a thin CRT display with a matrix of
2 cathodes, comprising the steps of:
3 measuring the emission characteristics of a cathode in the matrix of cathodes;
4 deriving the calibration parameters of a cathode in the matrix of cathodes from the
5 measured emission characteristics of the corresponding cathode;
6 storing the calibration parameters of a cathode in the matrix of cathodes into a
7 calibration memory;
8 obtaining the correct driving parameters for a cathode in the matrix of cathodes by
9 using the calibration parameters of the corresponding cathode from the calibration
10 memory; and
11 driving a cathode in the matrix of cathodes with the correct driving parameters for the
12 corresponding cathode.
13
- 1 2. A method of claim 1 further comprising the step of:
2 storing into a video memory the correct driving parameters for a cathode in the
3 matrix of cathodes.
4
- 1 3. A method of claim 1 wherein said step of measuring further comprises the step of:
2 measuring the emission current of the cathode for a set of driving parameters by
3 using a current detector connected to the anode of the thin CRT display.
4
- 1 4. A method of claim 1 wherein said step of measuring further comprises the step of:
2 measuring the light intensities of the pixel associated with the cathode in a dark
3 chamber for a set of driving parameters by using a photo detector.
4
- 1 5. A method of claim 1 wherein said step of deriving further comprises the step of
2 using the measured emission characteristics of the cathode directly as the calibration
3 parameters of the corresponding cathode.
4
- 1 6. A method of claim 1 wherein

- 1 1. A method for improving the display uniformity of a thin CRT display with a matrix of
2 cathodes, comprising the steps of:
3 measuring the emission characteristics of a cathode in the matrix of cathodes;
4 deriving the calibration parameters of a cathode in the matrix of cathodes from the
5 measured emission characteristics of the corresponding cathode;
6 storing the calibration parameters of a cathode in the matrix of cathodes into a
7 calibration memory;
8 obtaining the correct driving parameters for a cathode in the matrix of cathodes by
9 using the calibration parameters of the corresponding cathode from the calibration
10 memory; and
11 driving a cathode in the matrix of cathodes with the correct driving parameters for the
12 corresponding cathode.
13
- 1 2. A method of claim 1 further comprising the step of:
2 storing into a video memory the correct driving parameters for a cathode in the
3 matrix of cathodes.
4
- 1 3. A method of claim 1 wherein said step of measuring further comprises the step of:
2 measuring the emission current of the cathode for a set of driving parameters by
3 using a current detector connected to the anode of the thin CRT display.
4
- 1 4. A method of claim 1 wherein said step of measuring further comprises the step of:
2 measuring the light intensities of the pixel associated with the cathode in a dark
3 chamber for a set of driving parameters by using a photo detector.
4
- 1 5. A method of claim 1 wherein said step of deriving further comprises the step of
2 using the measured emission characteristics of the cathode directly as the calibration
3 parameters of the corresponding cathode.
4
- 1 6. A method of claim 1 wherein

2 said step of deriving further comprises the step of determining the correct driving
3 parameters for all gray levels of the cathode by using the measured emission
4 characteristics of the corresponding cathode as the row data;
5 said step of storing further comprises the step of storing the correct driving
6 parameters for all gray levels of the cathode into the calibration memory; and
7 said step of obtaining further comprises the step of fetching the correct driving
8 parameters for the corresponding cathode from the calibration memory.

9
1 7. A method of claim 1 wherein

2 said step of deriving further comprises the step of determining the correct driving
3 parameters for selected gray levels of the cathode by using the measured
4 emission characteristics of the corresponding cathode as the row data;
5 said step of storing further comprises the step of storing the correct driving
6 parameters for selected gray levels of the cathode into the calibration memory;
7 and
8 said step of obtaining further comprises the step of calculating the correct driving
9 parameters by using the correct driving parameters for selected gray levels of
10 the corresponding cathode from the calibration memory as the raw data.

11
1 8. A method of claim 7 wherein said step of calculating is performed based on
2 linear approximation.

3
1 9. A method of claim 7 wherein said step of calculating is performed with a
2 dedicated microprocessor .

3
1 10. A method of claim 1 wherein

2 said step of deriving further comprises the step of determining the calibration
3 parameters of the cathode based on a device model by using the measured
4 emission characteristics of the corresponding cathode as the row data; and

5 said step of obtaining further comprises the step of calculating the correct driving
6 parameters by using a device model as the algorithm and by using the
7 calibration parameters of the corresponding cathode from the calibration
8 memory as the raw data .

9
1 11. A method of claim 10 wherein said step of calculating is a step which is
2 performed with a dedicated microprocessor.

3
1 12. A method of claim 1 wherein

2 said step of deriving further comprises the step of determining the slope of the
3 measured emission characteristics of the corresponding cathode in the case
4 that the emission characteristics is linear;

5 said step of storing further comprises the step of storing the calculated slope of the
6 measured emission characteristics of the cathode into the calibration memory
7 as the calibration parameter of the cathode; and

8 said step of obtaining further comprises the step of calculating the correct driving
9 parameters by using the calculated slope of the measured emission
10 characteristics of the corresponding cathode from the calibration memory as
11 the raw data .

12
1 13. A method of claim 12 wherein said step of calculating is performed with a
2 dedicated microprocessor.

3
1 14. A method of claim 1 wherein said step of driving further comprises using a
2 driving method selected from a group consisting of voltage-driving method,
3 current-driving method, voltage-time driving method, current-time driving
4 method, any driving method with amplitude modulation, any driving method with
5 pulse width modulation, any hybrid driving method with both amplitude
6 modulation and pulse width modulation, and any combination thereof .
7

8

1 15. A thin CRT display with improved display uniformity, comprising:

2 an anode plate;

3 a matrix of cathodes being deposited on a plane facing said anode plate ;

4 a cathode in said matrix of cathodes, and said cathode can be individually addressed;

5 a calibration memory having at least one calibration parameter of said cathode stored
6 therein;

7 electronic circuitry for obtaining the correct driving parameters for said cathode by

8 using the calibration parameter of said cathode from said calibration memory; and

9 electronic circuitry for driving said cathode with the correct driving parameters for
10 said cathode.

11

1 16. A thin CRT display of claim 15 further comprising:

2 a video memory;

3 electronic circuitry for storing into said video memory the correct driving
4 parameters for said cathode.

5

1 17. A thin CRT display of claim 15 further comprising:

2 a current detector, and said current detector is connected to said anode plate; and

3 measurement circuitry for measuring the emission current of said cathode for a set
4 of driving parameters by using said current detector.

5

1 18. A thin CRT display of claim 15, 16 or 17, wherein said cathode is selected from a

2 group consisting of field emission cathode, surface conducting electron cathode,

3 MIS cathode, silicon avalanche cathode, diamond cathode, MIM cathode, pn

4 junction cathode, Schottky junction cathode, and any combination thereof .

5

1 19. A thin CRT display of claim 15, 16 or 17, wherein said electronic circuitry for

2 driving further comprises electronic circuitry utilizing a driving method selected

3 from a group consisting of voltage-driving method, current-driving method,

4 voltage-time driving method, current-time driving method, any driving method
5 with amplitude modulation, any driving method with pulse width modulation, any
6 hybrid driving method with both amplitude modulation and pulse width
7 modulation, and any combination thereof .
8

1 20. A thin CRT display of claim 15, 16 or 17, wherein said electronic circuitry for
2 obtaining further comprises a microprocessor selected from a group consisting of
3 programmable microprocessor, non-programmable microprocessor comprising
4 hardware logic gate elements, and the combination thereof.
5

1 21. A thin CRT display of claim 15, 16 or 17, wherein
2 the calibration parameter of said cathode is chosen to be the correct driving
3 parameter for a gray level of said cathode, and said calibration memory having
4 the correct driving parameters for all gray levels of said cathode stored therein
5 as calibration parameters; and
6 said electronic circuitry for obtaining further comprises electronic circuitry for
7 fetching the correct driving parameters for said cathode from said calibration
8 memory.
9

1 22. A thin CRT display of claim 15, 16 or 17, wherein
2 the calibration parameter of said cathode is chosen to be the correct driving
3 parameter for a gray level of said cathode, and said calibration memory having
4 the correct driving parameters for selected gray levels of said cathode stored
5 therein as calibration parameters; and
6 said electronic circuitry for obtaining further comprises electronic circuitry for
7 calculating the correct driving parameters by using the correct driving
8 parameters for selected gray levels of said cathode from said calibration
9 memory as the raw data.
10

1 23. A thin CRT display of claim 22 wherein

2 said electronic circuitry for calculating further comprises electronic circuitry
3 performing calculations based on linear approximation.

4

1 24. A thin CRT display of claim 15, 16 or 17, wherein
2 the calibration parameter of said cathode is chosen to be the fitting parameters
3 based on a device model for the emission characteristics of said cathode, and
4 said calibration memory having the fitting parameters stored therein as
5 calibration parameters; and
6 said electronic circuitry for obtaining further comprises electronic circuitry for
7 calculating the correct driving parameters by using the device model as the
8 algorithm and by using the fitting parameters from said calibration memory as
9 the raw data .

10

1 25. A thin CRT display of claim 15, 16 or 17, wherein
2 the calibration parameter of said cathode is chosen to be the slope of the measured
3 emission characteristics of said cathode in the case that the emission
4 characteristics is linear, and said calibration memory having the slope stored
5 therein as the calibration parameter; and
6 said electronic circuitry for obtaining further comprises electronic circuitry for
7 calculating the correct driving parameters by using the slope from said
8 calibration memory as the raw data .

9

10

1 26. An electronic driver for driving a thin CRT display having a matrix of cathodes,
2 comprising:
3 a calibration memory having at least one calibration parameter stored therein for each
4 cathode in the matrix of cathodes ; and
5 electronic circuitry for obtaining the correct driving parameters for each cathode in
6 the matrix of cathodes by using the calibration parameter of the corresponding
7 cathode from said calibration memory.

8

1

27. An electronic driver of claim 26 further comprising:

2

a video memory;

3

electronic circuitry for storing into said video memory the correct driving

4

parameters for each cathode in the matrix of cathodes.

5

1

28. An electronic driver of claim 26 further comprising:

2

row-driving electronics for selecting a row of cathodes in the matrix of cathodes;

3

and

4

column-driving electronics for driving each cathode in the selected row of

5

cathodes with the correct driving parameters for the corresponding cathode.

6

1

29. An electronic driver of claim 28 wherein said column-driving electronics

2

further comprises electronic circuitry utilizing a driving method selected from

3

a group consisting of voltage-driving method, current-driving method,

4

voltage-time driving method, current-time driving method, any driving

5

method with amplitude modulation, any driving method with pulse width

6

modulation, any hybrid driving method with both amplitude modulation and

7

pulse width modulation, and any combination thereof.

8

1

30. An electronic driver of claim 26, 27 or 28, wherein

2

the calibration parameter for each cathode is chosen to be the correct driving

3

parameter for a gray level of the corresponding cathode, and said calibration

4

memory having the correct driving parameters for all gray levels of each

5

cathode stored therein as calibration parameters; and

6

said electronic circuitry for obtaining further comprises electronic circuitry for

7

fetching the correct driving parameters for each cathode from said calibration

8

memory.

9

1

31. An electronic driver of claim 26, 27 or 28, wherein

2 the calibration parameter for each cathode is chosen to be the correct driving
3 parameter for a gray level of the corresponding cathode, and said calibration
4 memory having the correct driving parameters for selected gray levels of each
5 cathode stored therein as calibration parameters; and
6 said electronic circuitry for obtaining further comprises electronic circuitry for
7 calculating the correct driving parameters by using the correct driving
8 parameters for selected gray levels of the corresponding cathode from said
9 calibration memory as the raw data.

10
1 32. A thin CRT display of claim 31 wherein
2 said electronic circuitry for calculating further comprises electronic circuitry
3 performing calculations based on linear approximation.

4
1 33. An electronic driver of claim 26, 27 or 28, wherein
2 the calibration parameter for each cathode is chosen to be the fitting parameters
3 based on a device model for the emission characteristics of the corresponding
4 cathode, and said calibration memory having the fitting parameters stored
5 therein as calibration parameters; and
6 said electronic circuitry for obtaining further comprises electronic circuitry for
7 calculating the correct driving parameters by using the device model as the
8 algorithm and by using the fitting parameters from said calibration memory as
9 the raw data .

10
1 34. An electronic driver of claim 26, 27 or 28, wherein
2 the calibration parameter for each cathode is chosen to be the slope of the
3 measured emission characteristics of the corresponding cathode in the case
4 that the emission characteristics is linear, and said calibration memory having
5 the slope stored therein as said calibration parameter; and
6 said electronic circuitry for obtaining the correct driving parameters for each
7 cathode further comprises electronic circuitry for calculating the correct

8 driving parameters by using the slope from said calibration memory as the raw
9 data .
10
11

1 35. A thin CRT display with calibration capability comprising:
2 an anode plate;
3 a matrix of cathodes being deposited on a plane facing said anode plate ;
4 a cathode in said matrix of cathodes, and said cathode can be individually addressed;
5 a current detector, and said current detector is connected to said anode plate; and
6 measurement circuitry for measuring the emission current of said cathode for a set of
7 driving parameters by using said current detector.
8

1 36. A thin CRT display of claim 35 further comprising
2 electronic circuitry for deriving the calibration parameters of said cathode from
3 the measured emission characteristics of said cathode;
4 a calibration memory having at least one calibration parameter of said cathode
5 stored therein;
6 electronic circuitry for obtaining the correct driving parameters for said cathode
7 by using the calibration parameter of said cathode from said calibration
8 memory; and
9 electronic circuitry for driving said cathode with the correct driving parameters for
10 said cathode.

AMENDED CLAIMS

[received by the International Bureau on 19 May 1999 (19.05.99);
original claims 1-36 replaced by new claims 1-30 (10 pages)]

- 1 1. A method for creating a video data signal compensated for the non-uniformity of a
2 thin CRT display having a matrix of cathodes, comprising the steps of:
3 measuring the emission curve of each cathode in the matrix of cathodes by
4 measuring at least one data point on the emission curve;
5 deriving a set of fitting parameters for the emission curve of each cathode in the
6 matrix of cathodes from the measured data points of the corresponding
7 cathode;
8 storing the set of fitting parameters for the emission curve of each cathode in the
9 matrix of cathodes into a calibration memory;
10 obtaining the compensated video word for each cathode in the matrix of cathodes
11 by using the set of fitting parameters for the emission curve of the
12 corresponding cathode from the calibration memory;
13 storing into a video memory having a matrix of memory-cells the compensated
14 video word for each cathode in the matrix of cathodes; and
15 creating the compensated video data signal by fetching the compensated video
16 word for each cathode from the video memory.
17
18
- 1 2. A method for creating a video data signal compensated for the non-uniformity of a
2 thin CRT display having a matrix of cathodes, comprising the steps of:
3 measuring the emission curve of each cathode in the matrix of cathodes by
4 measuring at least one data point on the emission curve;
5 deriving a set of fitting parameters for the emission curve of each cathode in the
6 matrix of cathodes from the measured data points of the corresponding
7 cathode;
8 storing the set of fitting parameters for the emission curve of each cathode in the
9 matrix of cathodes into a calibration memory;
10 storing into a video memory having a matrix of memory-cells the uncompensated
11 video word for each cathode in the matrix of cathodes;

12 obtaining the compensated video word for each cathode in the matrix of cathodes
13 by using the set of fitting parameters for the emission curve of the
14 corresponding cathode from the calibration memory; and
15 creating the compensated video data signal by using the compensated video word
16 generated from the step of obtaining.

17

18

1 3. A method of claim 1 or 2 wherein
2 the video data signal is in the form of a series of digital word.

3

1 4. A method of claim 1 or 2 wherein
2 the video data signal is in an analog wave form that uses the amplitude
3 representing the luminosity of each pixel.

4

1 5. A method of claim 1 or 2 wherein said step of deriving further comprises
2 the step of storing the measured data points of the emission curve of each
3 cathode first into a nonvolatile memory; and
4 the step of loading the measured data points of the emission curve of each
5 cathode into a RAM from the nonvolatile memory.

6

1 6. A method of claim 1 or 2 wherein the calibration memory is a nonvolatile
2 memory.

3

1 7. A method of claim 1 or 2 wherein the calibration memory is a volatile memory
2 and said step of storing the set of fitting parameters further comprises
3 the step of storing the set of fitting parameters for the emission curve of each
4 cathode first into a nonvolatile memory; and
5 the step of loading the set of fitting parameters for the emission curve of each
6 cathode into the calibration memory from the nonvolatile memory.

7

1 8. A method of claim 1 or 2 wherein
2 said step of deriving further comprises the step of determining the correct
3 driving parameters for all gray levels of the cathode by using the measured

4 data points on the emission curve of the corresponding cathode as the row
5 data;
6 said step of storing further comprises the step of storing the correct driving
7 parameters for all gray levels of the cathode into the calibration memory;
8 and
9 said step of obtaining further comprises the step of fetching the correct driving
10 parameter for the corresponding cathode from the calibration memory.

11

1 9. A method of claim 1 or 2 wherein
2 said step of deriving further comprises the step of determining the correct
3 driving parameters for selected gray levels of the cathode by using the
4 measured data points on emission curve of the corresponding cathode as
5 the row data;
6 said step of storing further comprises the step of storing the correct driving
7 parameters for selected gray levels of the cathode into the calibration
8 memory; and
9 said step of obtaining further comprises the step of calculating the
10 compensated video word by using the correct driving parameters for
11 selected gray levels of the corresponding cathode from the calibration
12 memory as the raw data.

13

1 10. A method of claim 1 or 2 wherein
2 said step of deriving further comprises the step of determining the set of fitting
3 parameters for the emission curve of the cathode based on a device model
4 by using the measured data points on emission curve of the corresponding
5 cathode as the row data; and
6 said step of obtaining further comprises the step of calculating the
7 compensated video word by using the device model as the algorithm and
8 by using the set of fitting parameters for the emission curve of the
9 corresponding cathode from the calibration memory as the raw data.

10

1 11. A method of claim 1 or 2 wherein

2 each cathode in the matrix of cathodes is selected from a group consisting of field
3 emission cathode, surface conducting electron cathode, MIS cathode, silicon
4 avalanche cathode, diamond cathode, MIM cathode, pn junction cathode,
5 Schottky junction cathode, and any combination thereof.
6
7
8

1 12. A method for creating a video data signal compensated for the non-uniformity of a
2 thin CRT display having a matrix of cathodes, comprising the steps of:
3 measuring the emission curve of each cathode in the matrix of cathodes by
4 measuring at least one data point on the emission curve;
5 deriving a single fitting parameter for the emission curve of each cathode in the
6 matrix of cathodes from the measured data point of the corresponding cathode;
7 storing the single fitting parameter for the emission curve of each cathode in the
8 matrix of cathodes into a calibration memory;
9 obtaining the compensated video word for each cathode in the matrix of cathodes
10 by using the single fitting parameter for the emission curve of the
11 corresponding cathode from the calibration memory;
12 storing into a video memory having a matrix of memory-cells the compensated
13 video word for each cathode in the matrix of cathodes; and
14 creating the compensated video data signal by fetching the compensated video
15 word for each cathode from the video memory.
16
17

1 13. A method for creating a video data signal compensated for the non-uniformity of a
2 thin CRT display having a matrix of cathodes, comprising the steps of:
3 measuring the emission curve of each cathode in the matrix of cathodes by
4 measuring at least one data point on the emission curve;
5 deriving a single fitting parameter for the emission curve of each cathode in the
6 matrix of cathodes from the measured data points of the corresponding
7 cathode;
8 storing the single fitting parameter for the emission curve of each cathode in the
9 matrix of cathodes into a calibration memory;

10 storing into a video memory having a matrix of memory-cells the uncompensated
11 video word for each cathode in the matrix of cathodes;
12 obtaining the compensated video word for each cathode in the matrix of cathodes
13 by using the single fitting parameter for the emission curve of the
14 corresponding cathode from the calibration memory; and
15 creating the compensated video data signal by using the compensated video word
16 generated from the step of obtaining.

17

18

1 14. A method of claim 12 or 13 wherein the calibration memory is a nonvolatile
2 memory.

3

1

2

3

4

5

6

7

8

9

1 16. A video interfacing electronics, for creating a video data signal compensated for
2 the non-uniformity of a thin CRT display having a matrix of cathodes, having a
3 video memory for storing the video pattern, comprising:
4 a calibration memory having a set of fitting parameters for the emission curve
5 stored therein for each cathode in the matrix of cathodes;
6 electronic circuitry for obtaining the compensated video word for each cathode in
7 the matrix of cathodes by using the set of fitting parameters for the emission
8 curve of the corresponding cathode from said calibration memory;
9 electronic circuitry for storing into the video memory the compensated video word
10 for each cathode in the matrix of cathodes; and
11 electronic circuitry for creating the compensated video data signal by fetching the
12 compensated video word for each cathode from the video memory.

13

14

1 17. A video interfacing electronics, for creating a video data signal compensated for
2 the non-uniformity of a thin CRT display having a matrix of cathodes, having a
3 video memory for storing the video pattern. comprising:
4 a calibration memory having a set of fitting parameters for the emission curve
5 stored therein for each cathode in the matrix of cathodes;
6 electronic circuitry for storing into a video memory having a matrix of memory-
7 cells the uncompensated video word for each cathode in the matrix of
8 cathodes;
9 electronic circuitry for obtaining the compensated video word for each cathode in
10 the matrix of cathodes by using the set of fitting parameters for the emission
11 curve of the corresponding cathode from the calibration memory; and
12 electronic circuitry for creating the compensated video data signal by using the
13 compensated video word generated from the electronic circuitry for obtaining.

14

15

1 18. A video interfacing electronics of claim 16 or 17 wherein the calibration
2 memory is a nonvolatile memory.

3

1 19. A video interfacing electronics of claim 16 or 17 wherein the calibration
2 memory is a volatile memory, further comprising
3 a nonvolatile memory having the set of fitting parameters for the emission
4 curve of each cathode stored thereinto; and
5 electronic circuitry for loading the set of fitting parameters for the emission
6 curve of each cathode into said calibration memory from said nonvolatile
7 memory.

8

1 20. A video interfacing electronics of claim 16 or 17 wherein said electronic
2 circuitry for creating further comprising
3 electronic circuitry for creating the video data signal in the form of a series of
4 digital word.

5

1 21. A video interfacing electronics of claim 16 or 17 wherein said electronic
2 circuitry for creating further comprising
3 electronic circuitry for creating the video data in an analog wave form that uses
4 the amplitude representing the luminosity of each pixel.

5
1 22. A video interfacing electronics of claim 16 or 17 wherein
2 the fitting parameter for the emission curve of each cathode is chosen to be
3 the correct driving parameter for a gray level of the corresponding cathode,
4 and said calibration memory having the correct driving parameters for all
5 gray levels of each cathode stored therein as the fitting parameters; and
6 said electronic circuitry for obtaining further comprises electronic circuitry for
7 fetching the correct driving parameters for each cathode from said
8 calibration memory.

9
1 23. A video interfacing electronics of claim 16 or 17 wherein
2 the fitting parameter for the emission curve of each cathode is chosen to be the
3 correct driving parameter for a gray level of the corresponding cathode,
4 and said calibration memory having the correct driving parameters for
5 selected gray levels of each cathode stored therein as the fitting parameters;
6 and
7 said electronic circuitry for obtaining further comprises electronic circuitry for
8 calculating the compensated video word by using the correct driving
9 parameters for selected gray levels of the corresponding cathode from said
10 calibration memory as the raw data.

11
1 24. A video interfacing electronics of claim 16 or 17 wherein
2 the fitting parameter for the emission curve of said cathode is chosen to be the
3 fitting parameters based on a device model for the emission curve of said
4 cathode, and said calibration memory having the fitting parameters stored
5 therein; and
6 said electronic circuitry for obtaining further comprises electronic circuitry for
7 calculating the compensated video word by using the device model as the

8 algorithm and by using the fitting parameters from said calibration memory
9 as the raw data .

10

11

1 25. A video interfacing electronics, for creating a video data signal compensated for
2 the non-uniformity of a thin CRT display having a matrix of cathodes, having a
3 video memory for storing the video pattern, comprising:
4 a calibration memory having a single parameter for the emission curve stored
5 therein for each cathode in the matrix of cathodes;
6 electronic circuitry for obtaining the compensated video word for each cathode in
7 the matrix of cathodes by using the single parameter for the emission curve of
8 the corresponding cathode from said calibration memory;
9 electronic circuitry for storing into the video memory the compensated video word
10 for each cathode in the matrix of cathodes; and
11 electronic circuitry for creating the compensated video data signal by fetching the
12 compensated video word for each cathode from the video memory.

13

14

1 26. A video interfacing electronics, for creating a video data signal compensated for
2 the non-uniformity of a thin CRT display having a matrix of cathodes, having a
3 video memory for storing the video pattern, comprising:
4 a calibration memory having a single parameter for the emission curve stored
5 therein for each cathode in the matrix of cathodes;
6 electronic circuitry for storing into a video memory having a matrix of memory-
7 cells the uncompensated video word for each cathode in the matrix of
8 cathodes;
9 electronic circuitry for obtaining the compensated video word for each cathode in
10 the matrix of cathodes by using the single parameter for the emission curve of
11 the corresponding cathode from the calibration memory; and
12 electronic circuitry for creating the compensated video data signal by using the
13 compensated video word generated from electronic circuitry for obtaining.

14

15

1 27. A video interfacing electronics of claim 25 or 26 wherein the calibration
2 memory is a nonvolatile memory.

3

1 28. A video interfacing electronics of claim 25 or 26 wherein the calibration
2 memory is a volatile memory, further comprising
3 a nonvolatile memory having the single fitting parameter for the emission
4 curve of each cathode stored thereinto; and
5 electronic circuitry for loading the single fitting parameter for the emission
6 curve of each cathode into said calibration memory from said nonvolatile
7 memory.

8

9

10

1 29. A method for improving the display uniformity of a thin CRT display with a
2 matrix of cathodes, comprising the steps of:
3 measuring the emission curve of each cathode in the matrix of cathodes by
4 measuring plural data points on the emission curve;
5 deriving a set of fitting parameters for the emission curve of each cathode in the
6 matrix of cathodes from the measured data points of the corresponding
7 cathode, where the number of fitting parameters in the set of fitting parameters
8 being larger than one but less than the number of gray levels of each pixel;
9 storing the set of fitting parameters for the emission curve of each cathode in the
10 matrix of cathodes into a calibration memory;
11 storing into a video memory having a matrix of memory-cells the uncompensated
12 video word for each cathode in the matrix of cathodes;
13 creating an uncompensated video data signal by fetching the uncompensated video
14 word from the video memory;
15 obtaining the correct driving parameter for each cathode in the matrix of cathodes
16 by using the set of fitting parameters for the emission curve of the
17 corresponding cathode from the calibration memory, and by using the
18 uncompensated video data signal; and
19 driving each cathode in the matrix of cathodes with the correct driving parameter
20 for the corresponding cathode.

1 30. A method of claim 29 wherein
2 said step of deriving further comprises the step of determining the set of fitting
3 parameters for the emission curve of the cathode based on a device model
4 by using the measured data points on emission curve of the corresponding
5 cathode as the raw data; and
6 said step of obtaining further comprises the step of calculating the correct
7 driving parameter by using the device model as the algorithm and by using
8 the set of fitting parameters for the emission curve of the corresponding
9 cathode from the calibration memory as the raw data.
10
11

Statement under article 19(1)

A thin CRT display is normally driven by a video data signal created from a video memory (VRAM). To improve the display uniformity of a thin CRT display, in
5 EPO patent 755,042A and U. S. patent 5,262,689, the video data signal, presumably created from a video memory (VRAM), is corrected with a correction memory matrix, and converted into the correct driving voltage for each pixel.

In current patent application, I disclose methods and video interface electronics that create a video data signal which is already compensated for the non-
10 uniformity of each cathode.

The compensated video data signal can generally be created in two methods. Both methods need to use a calibration memory which stores the fitting parameters of each cathode's emission curve. With the first method, using the calibration memory, the video words are first compensated and written into the video memory. Then, the
15 compensated video data signal is created by fetching the compensated video words from the video memory. With the second method, the uncompensated video words are first written into the video memory. Then, using the calibration memory, the compensated video data signal is created by fetching the uncompensated video words from the video memory.

20 With current disclosed methods, all the corrections can be performed on the video card before the video data signal is created. Because video card already carry out significant amount of calculations (such as for real time video acceleration), it will be not too expansive to add additional calculations to the video card to create the compensated video words or the compensated video data signal.

25 In this patent application, I also disclose methods to reduce the memory requirement for the calibration memory. It takes great amount of the calibration memory to store all the data points on the emission curve of each cathode. With methods disclosed in this application, the emission curve of each cathode is modeled with a mathematical formula and a few fitting parameters, and for each emission
30 curve only a few fitting parameters need to be stored in the calibration memory. By storing only a few fitting parameters for each cathode, the correct driving parameter for each cathode can also be obtained from the uncompensated video data signal.

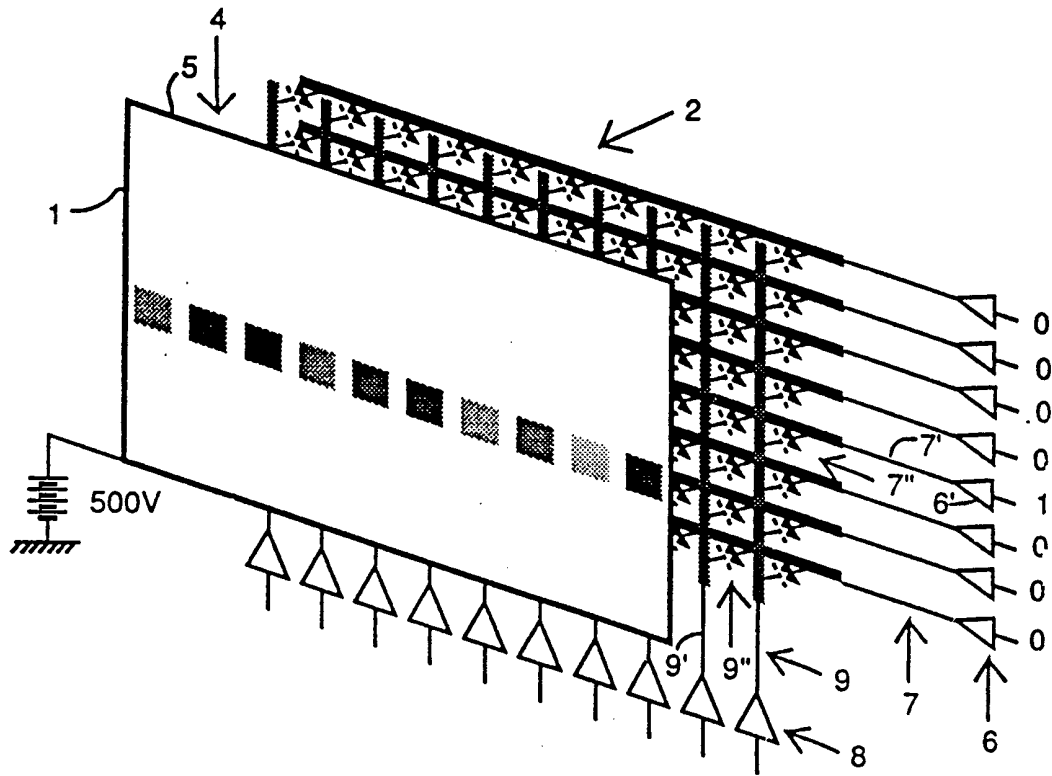

Fig. 1a (PRIOR ART)

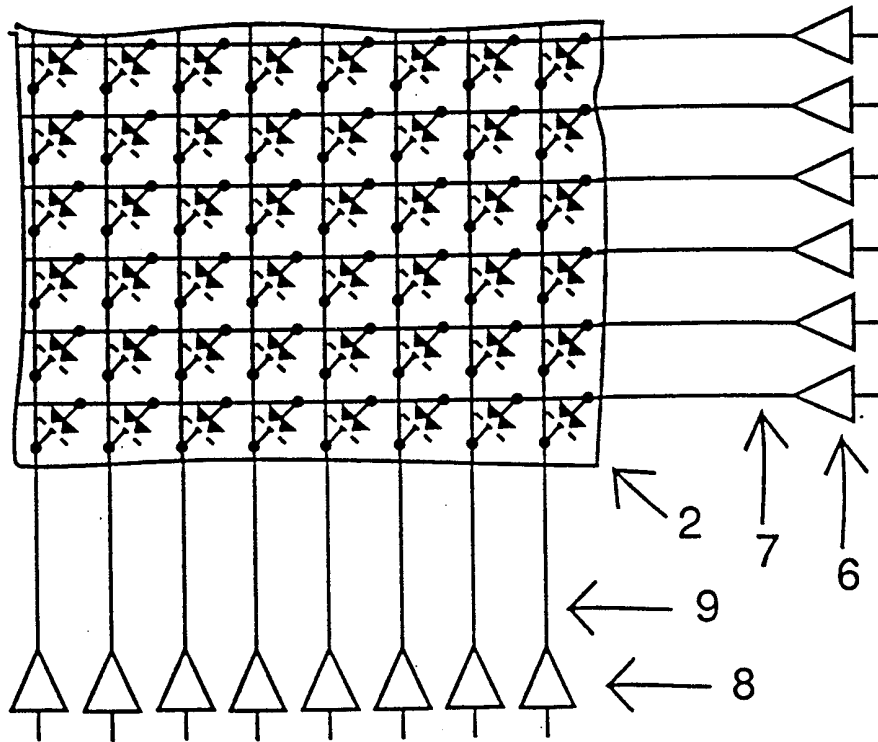

Fig. 1b (PRIOR ART)

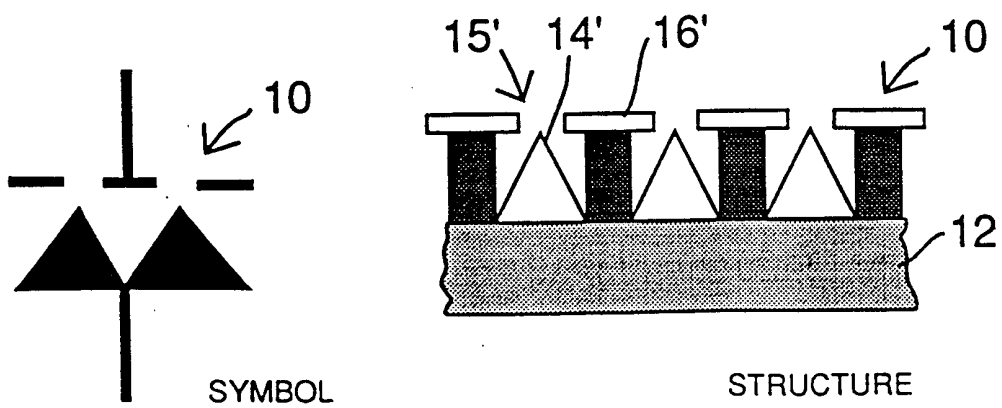

Fig. 1c (PRIOR ART)

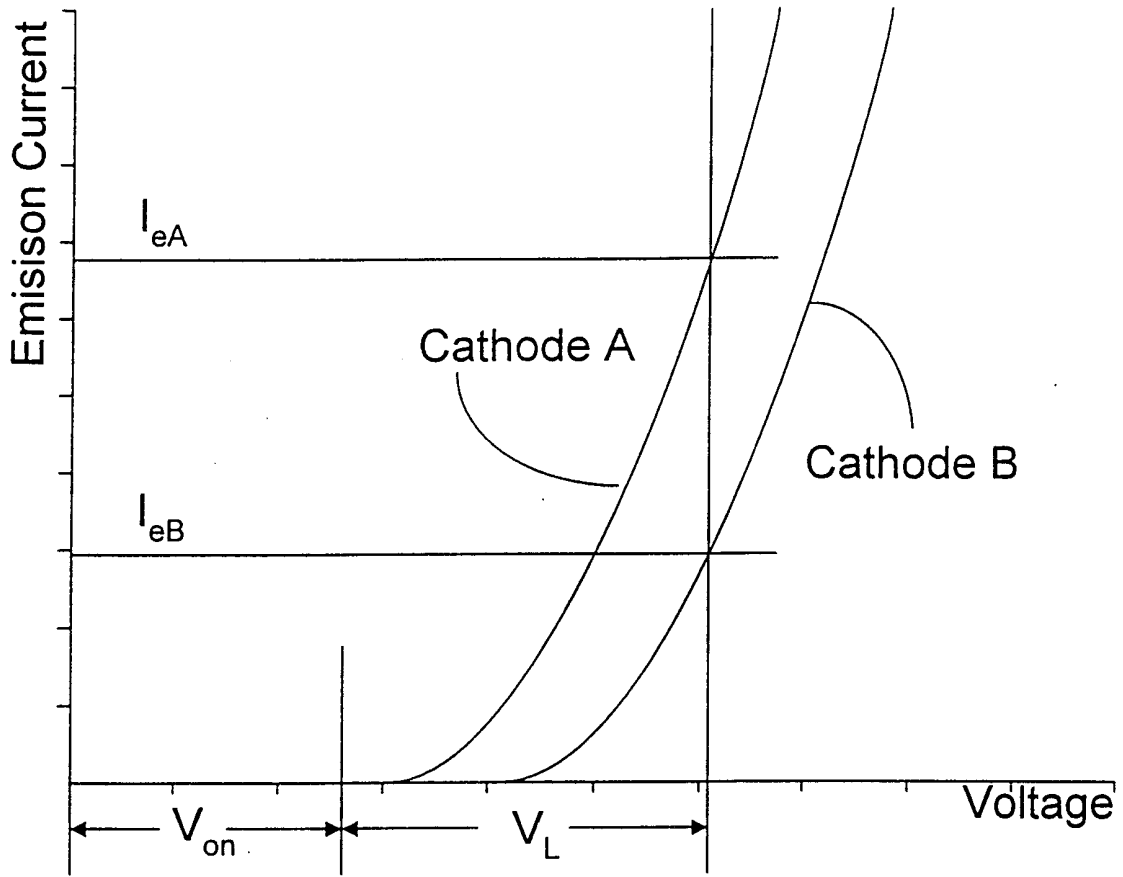

Figure 2a

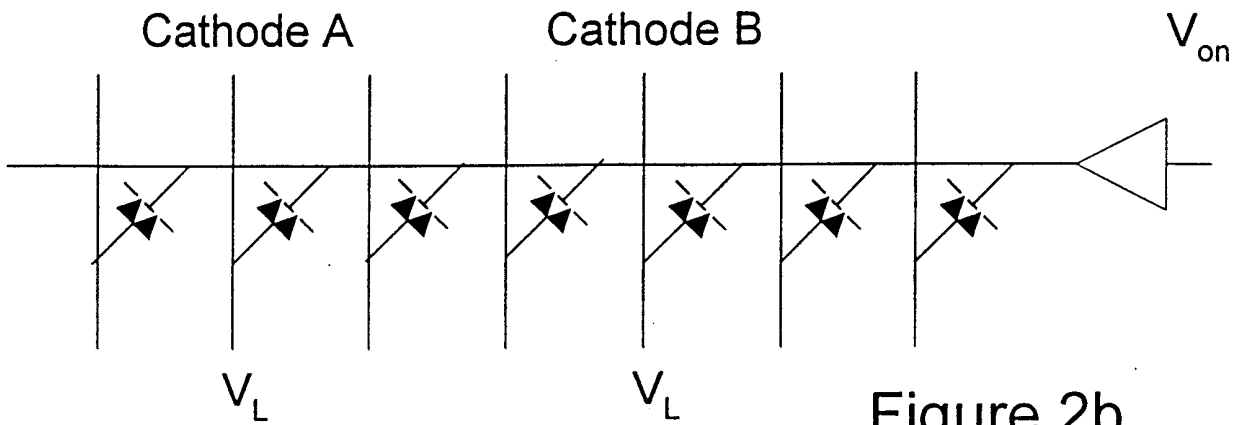

Figure 2b

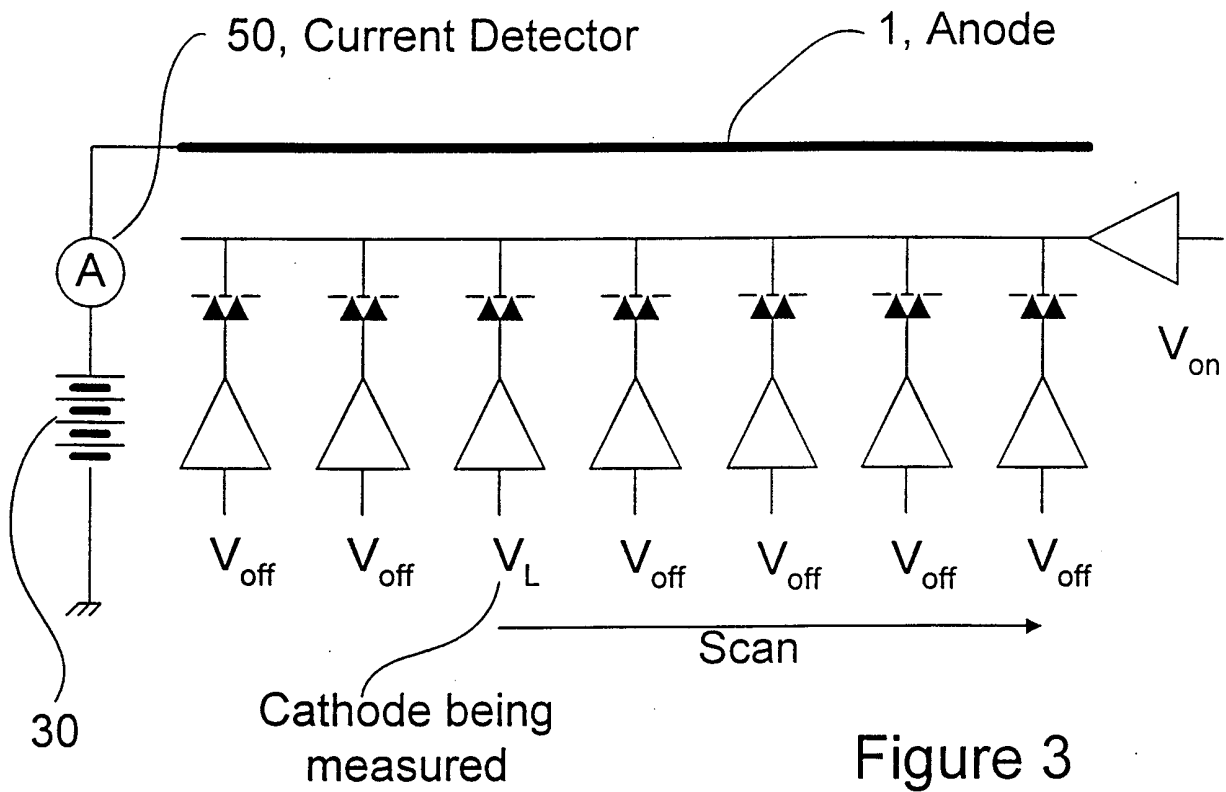

Figure 3

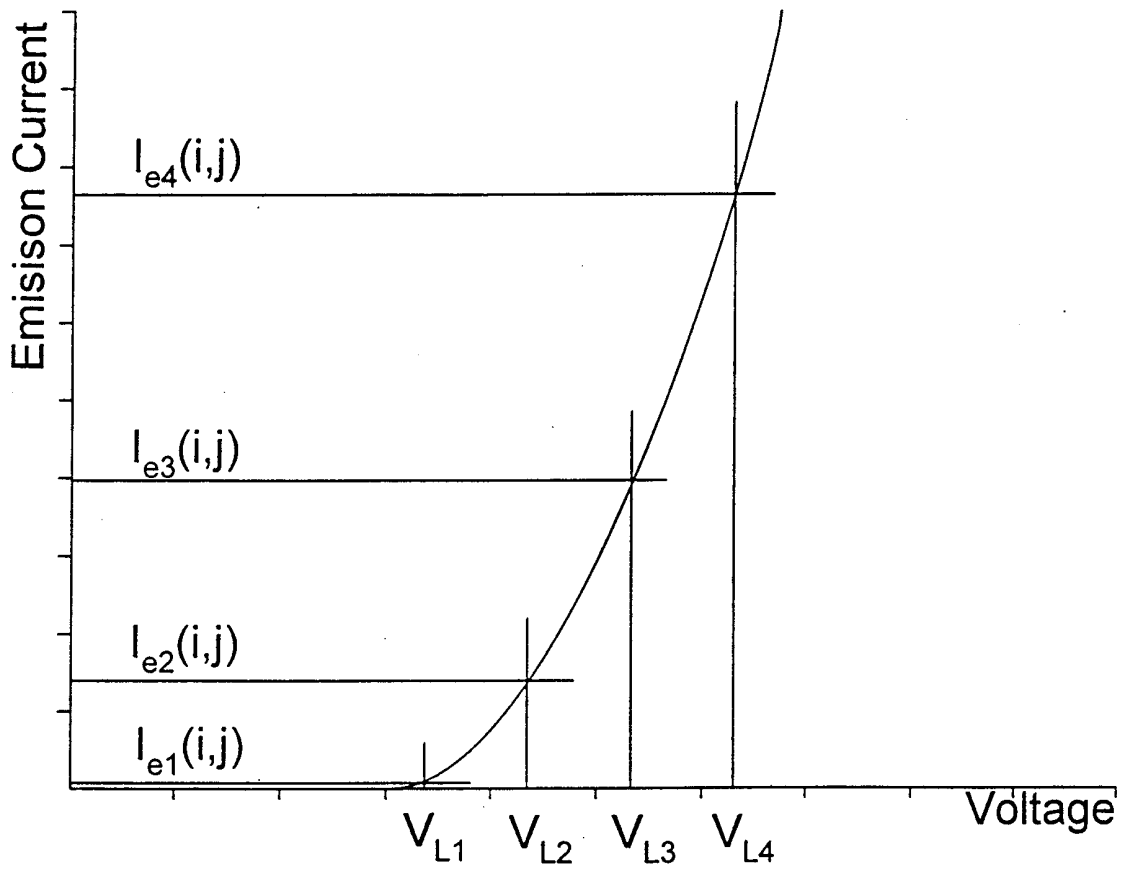

Figure 4a

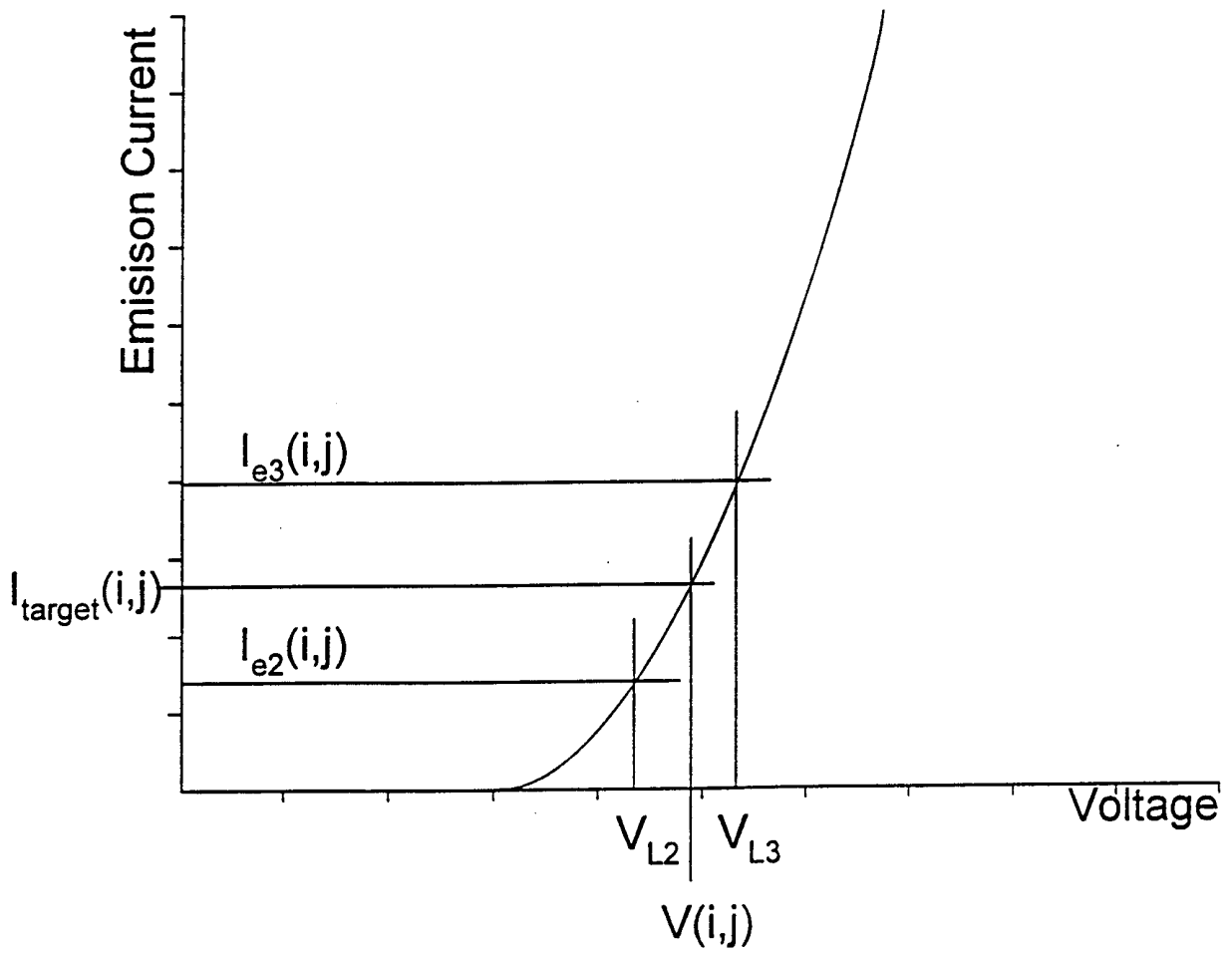

Figure 4b

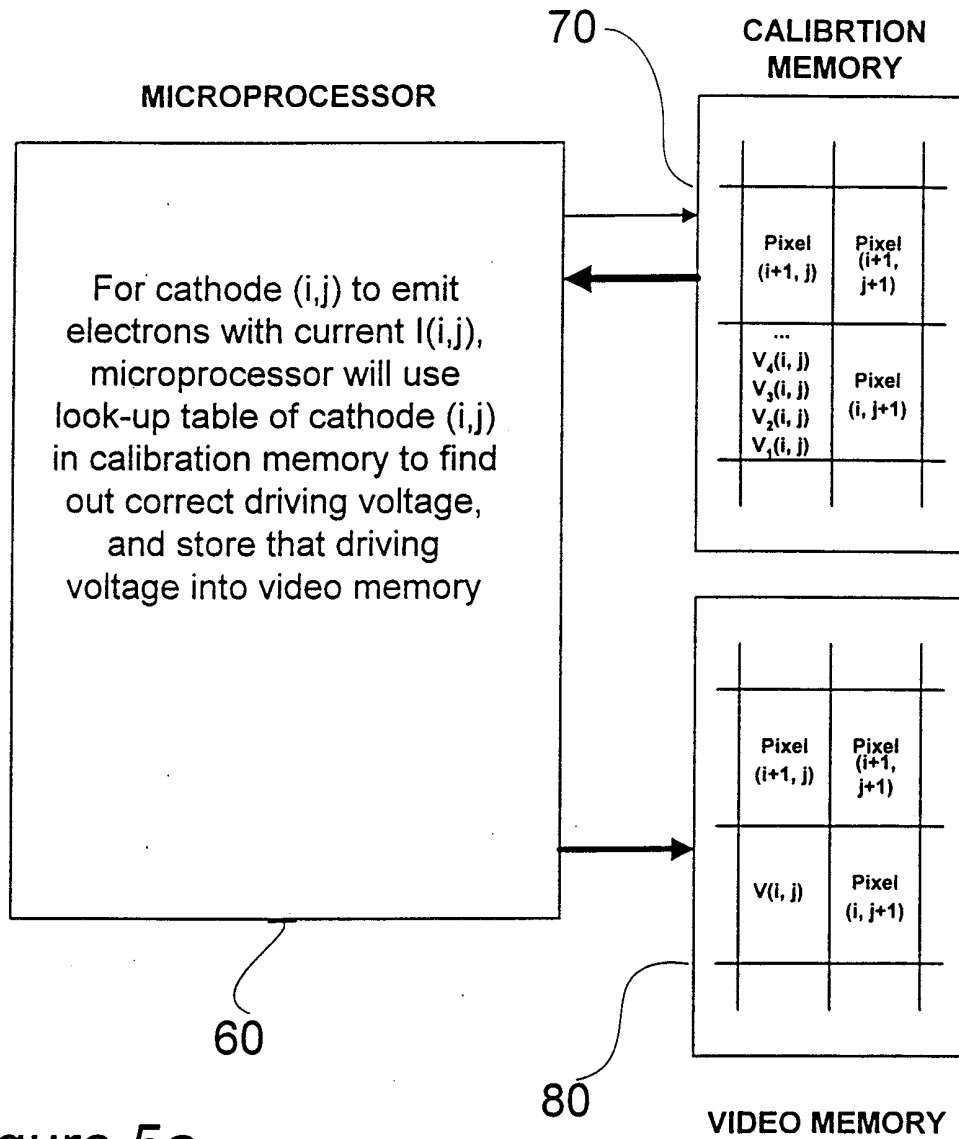

Figure 5a

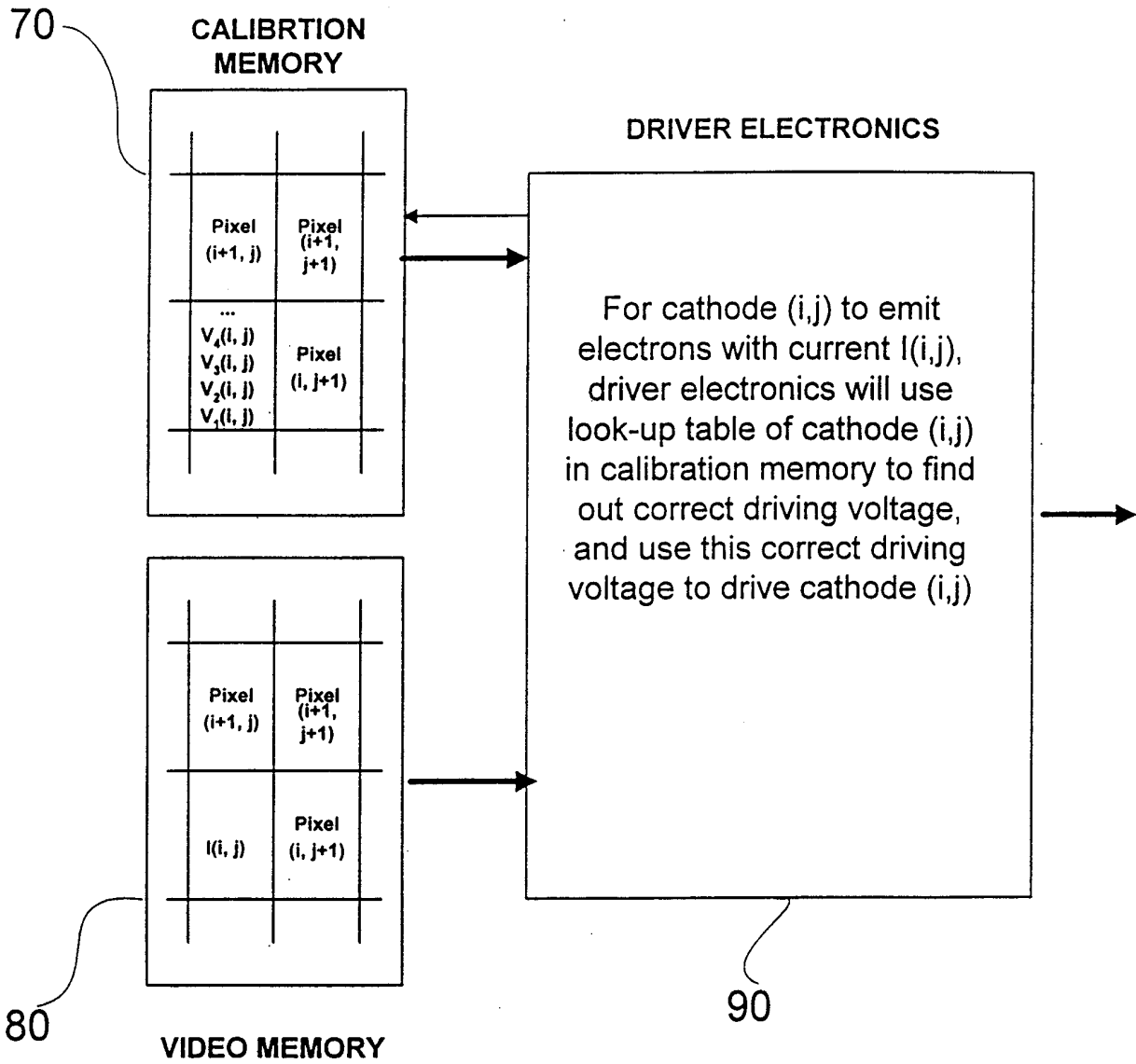

Figure 5b

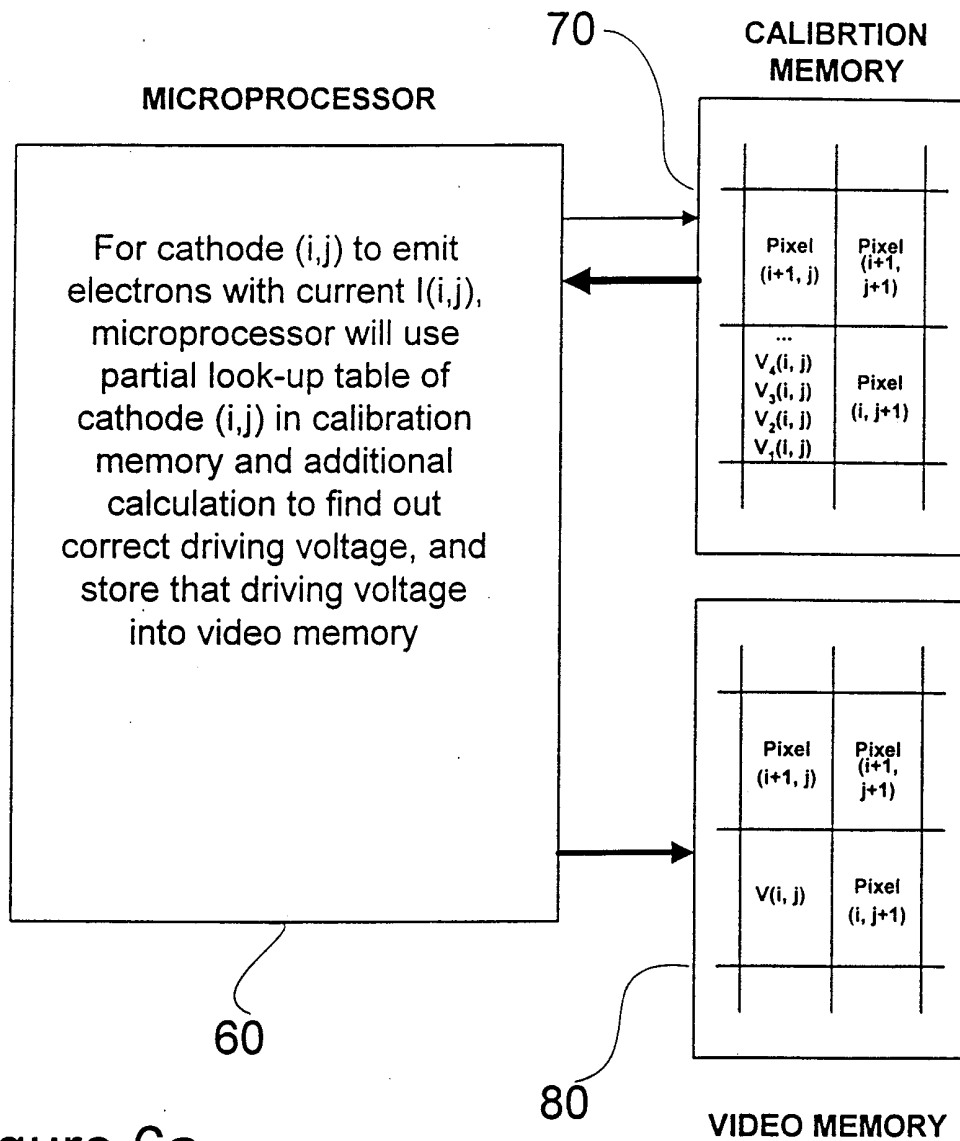

Figure 6a

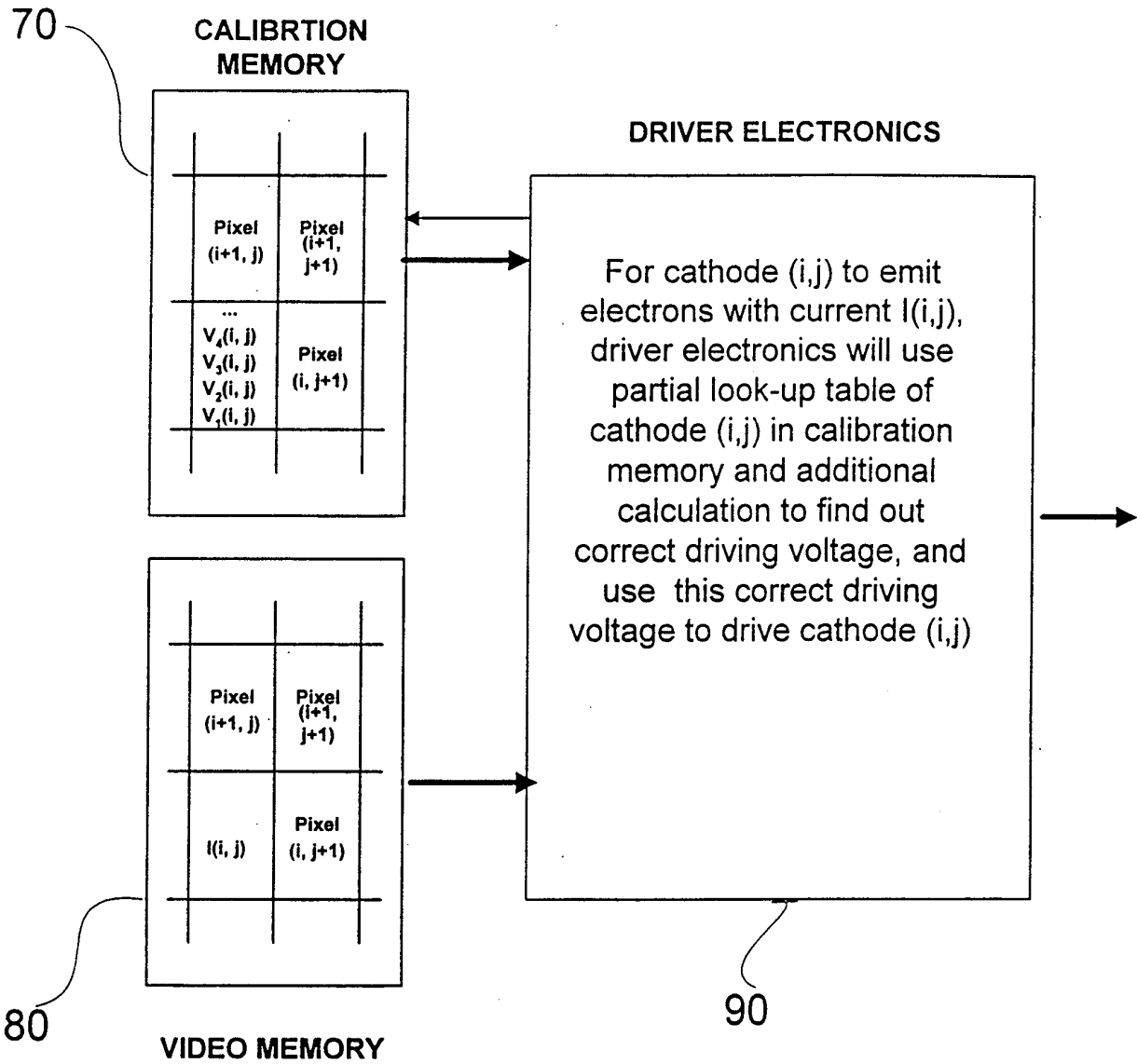

Figure 6b

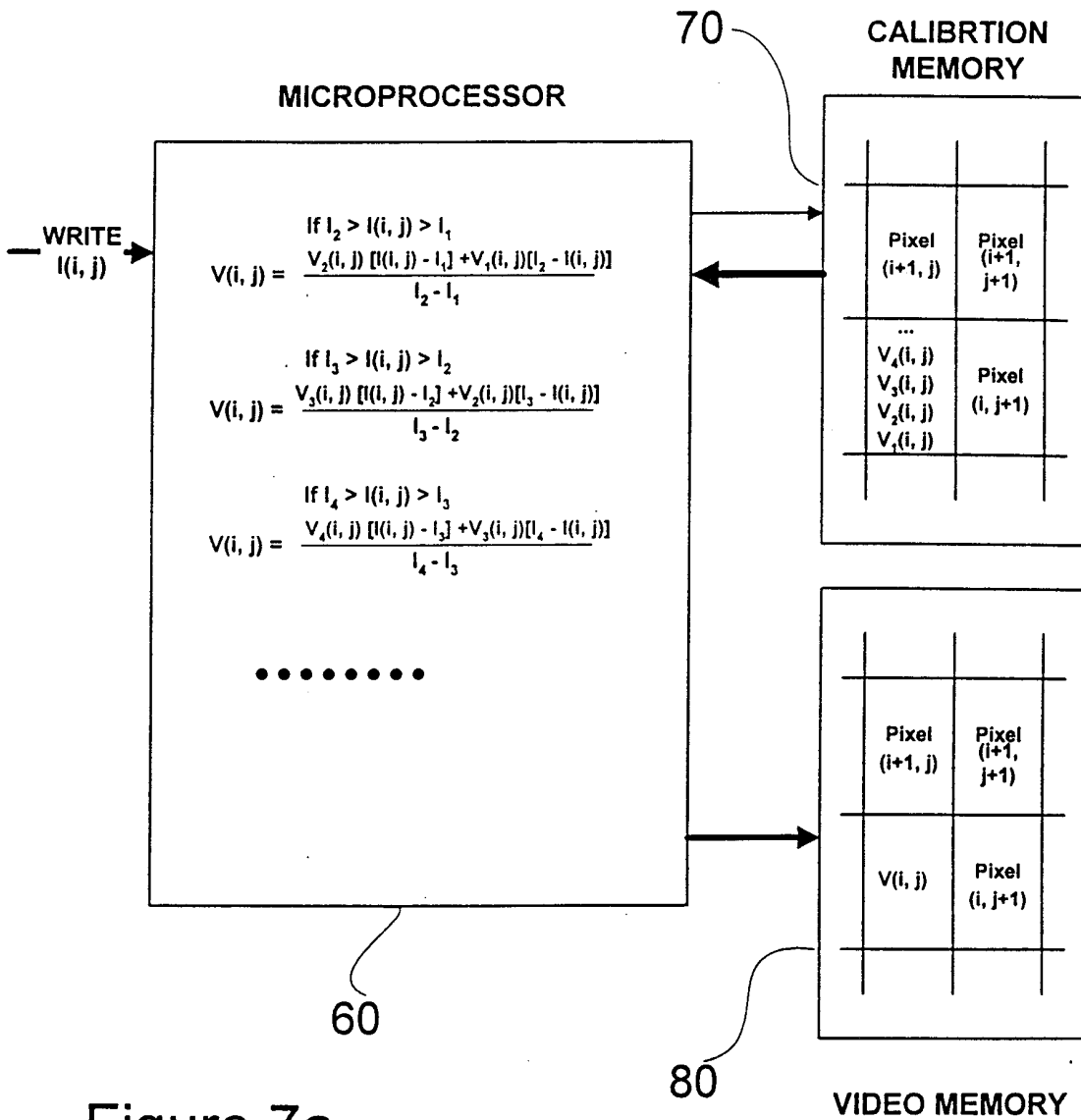

Figure 7a

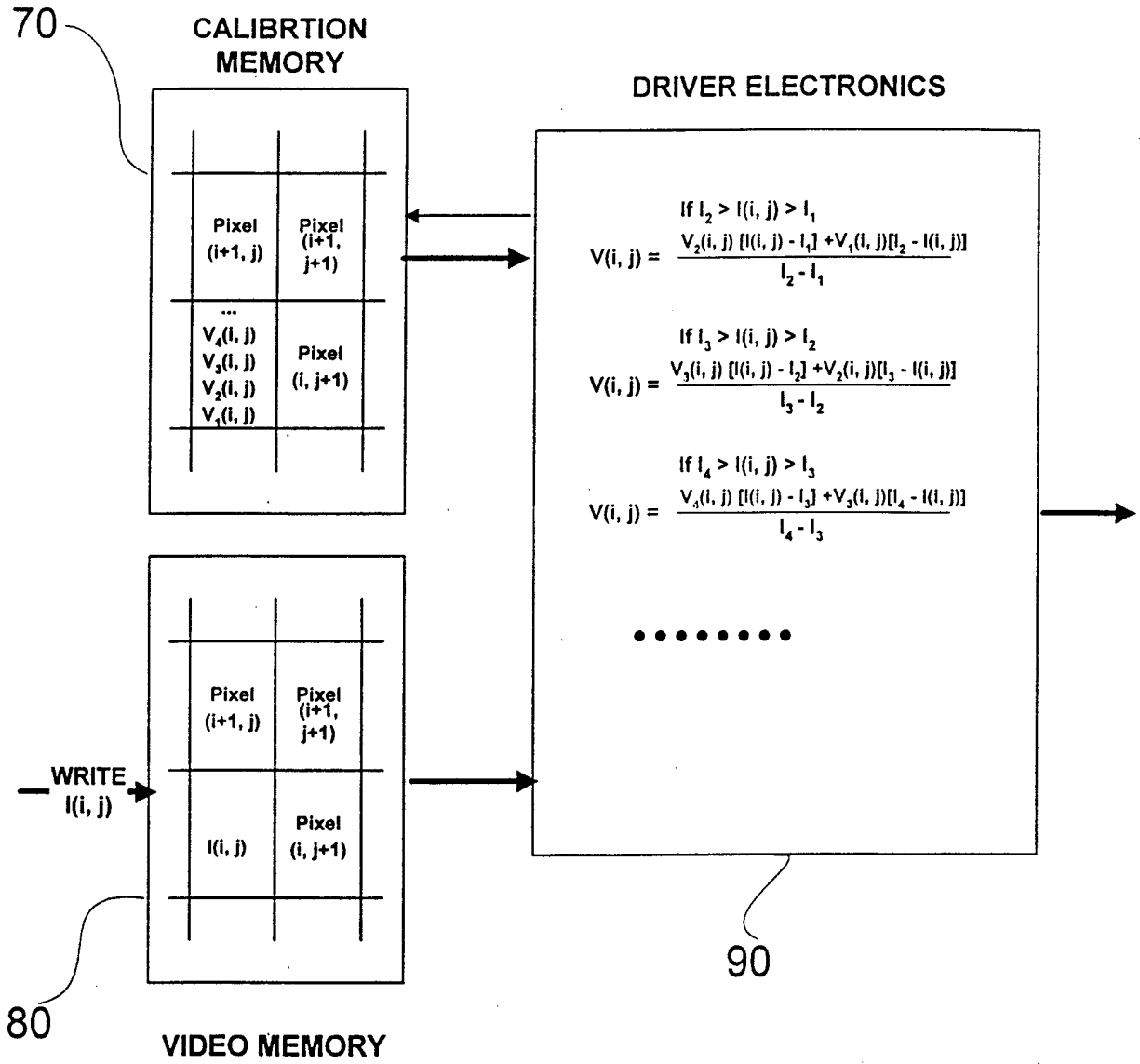

Figure 7b

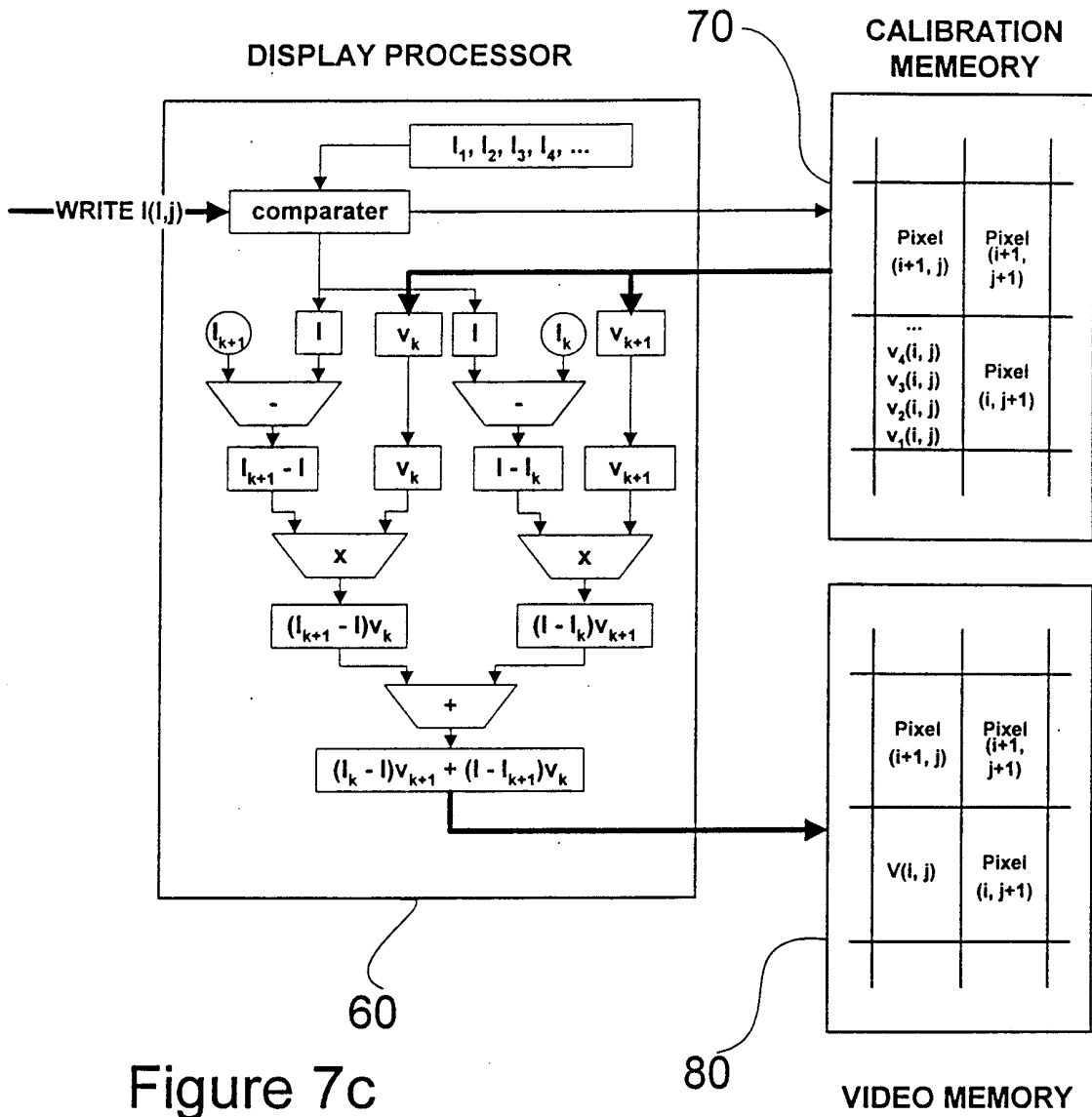

Figure 7c

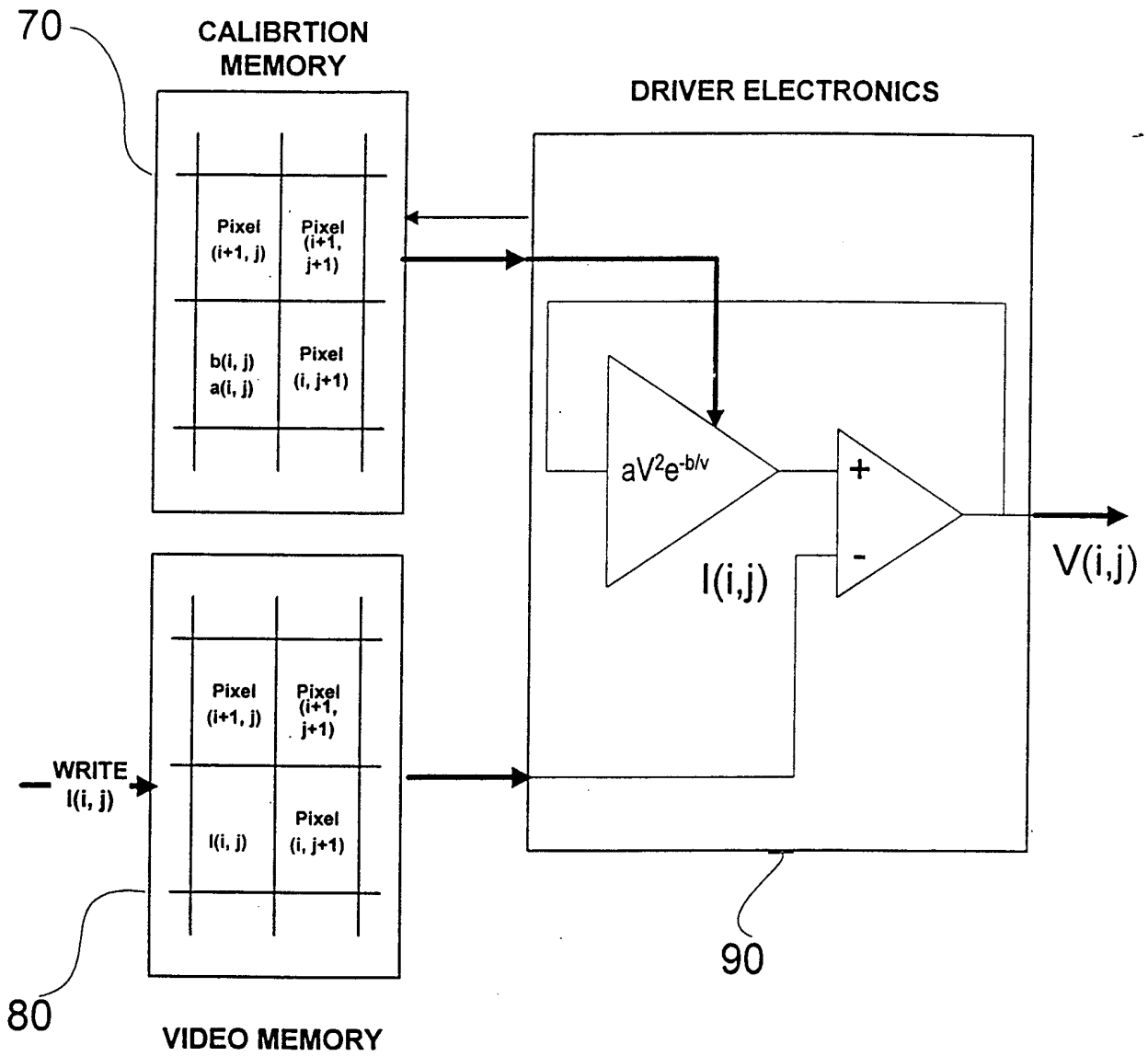

Figure 7d

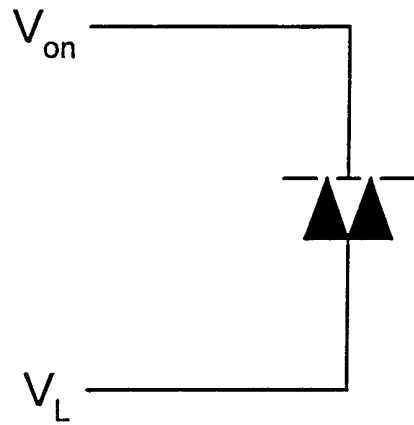

Figure 8a

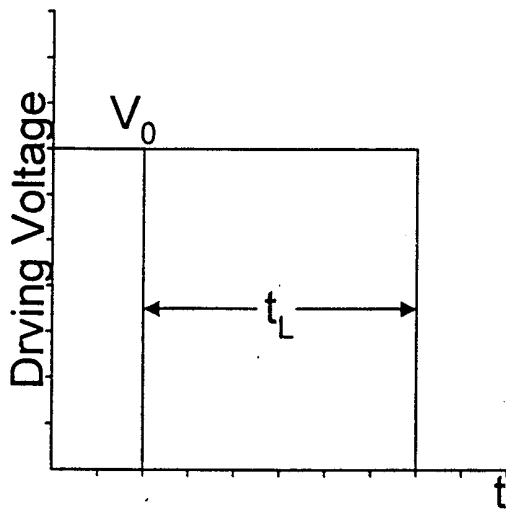

Figure 8b

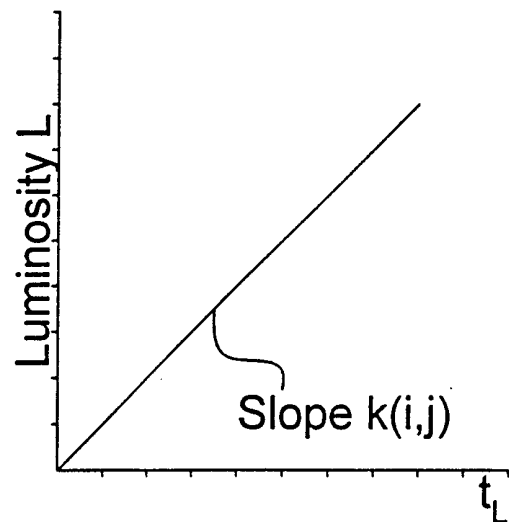

Figure 8c

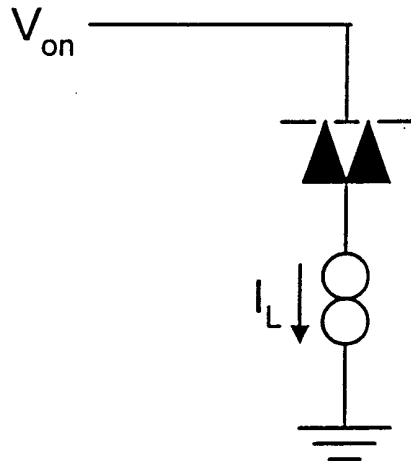

Figure 9a

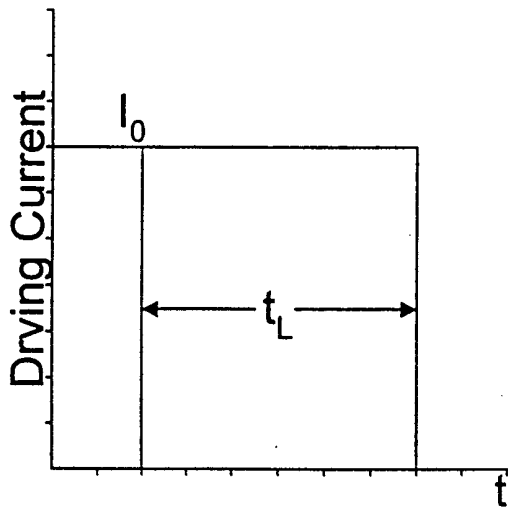

Figure 9b

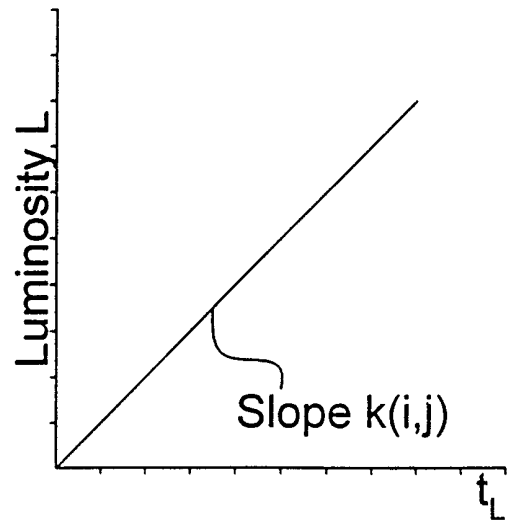

Figure 9c

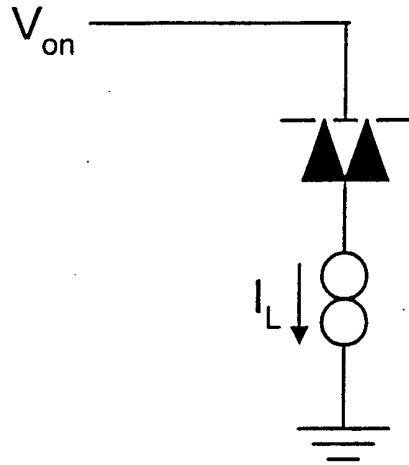

Figure 10a

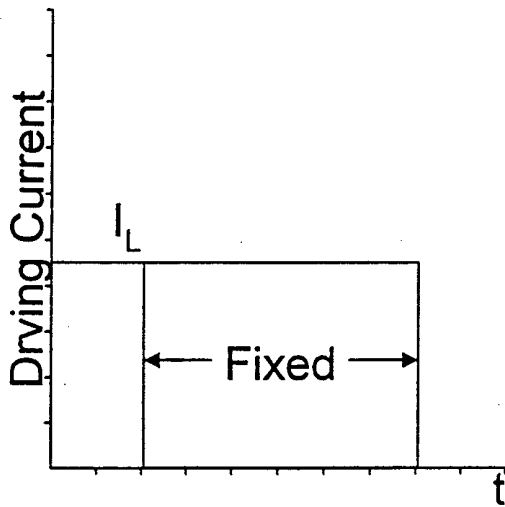

Figure 10b

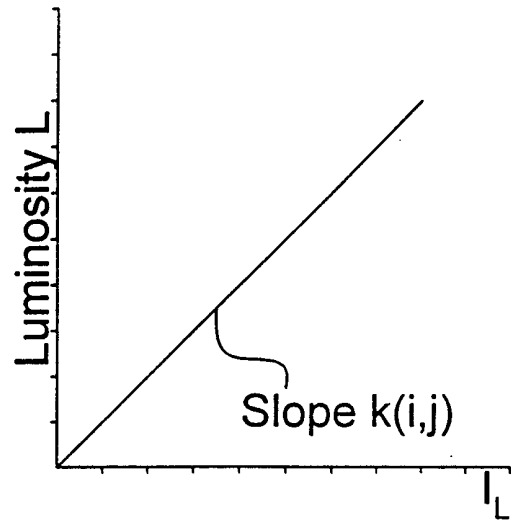

Figure 10c

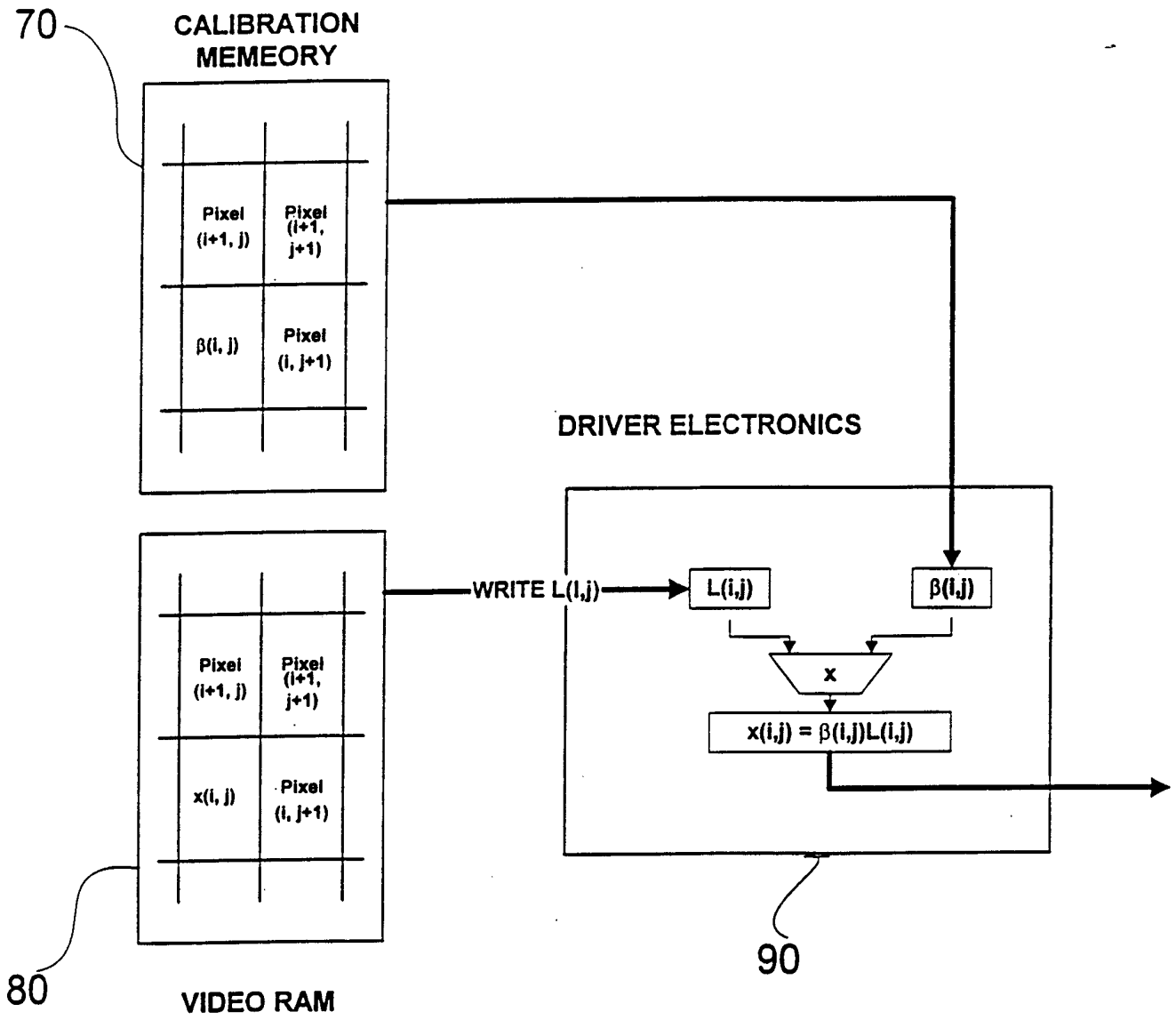

Figure 11b

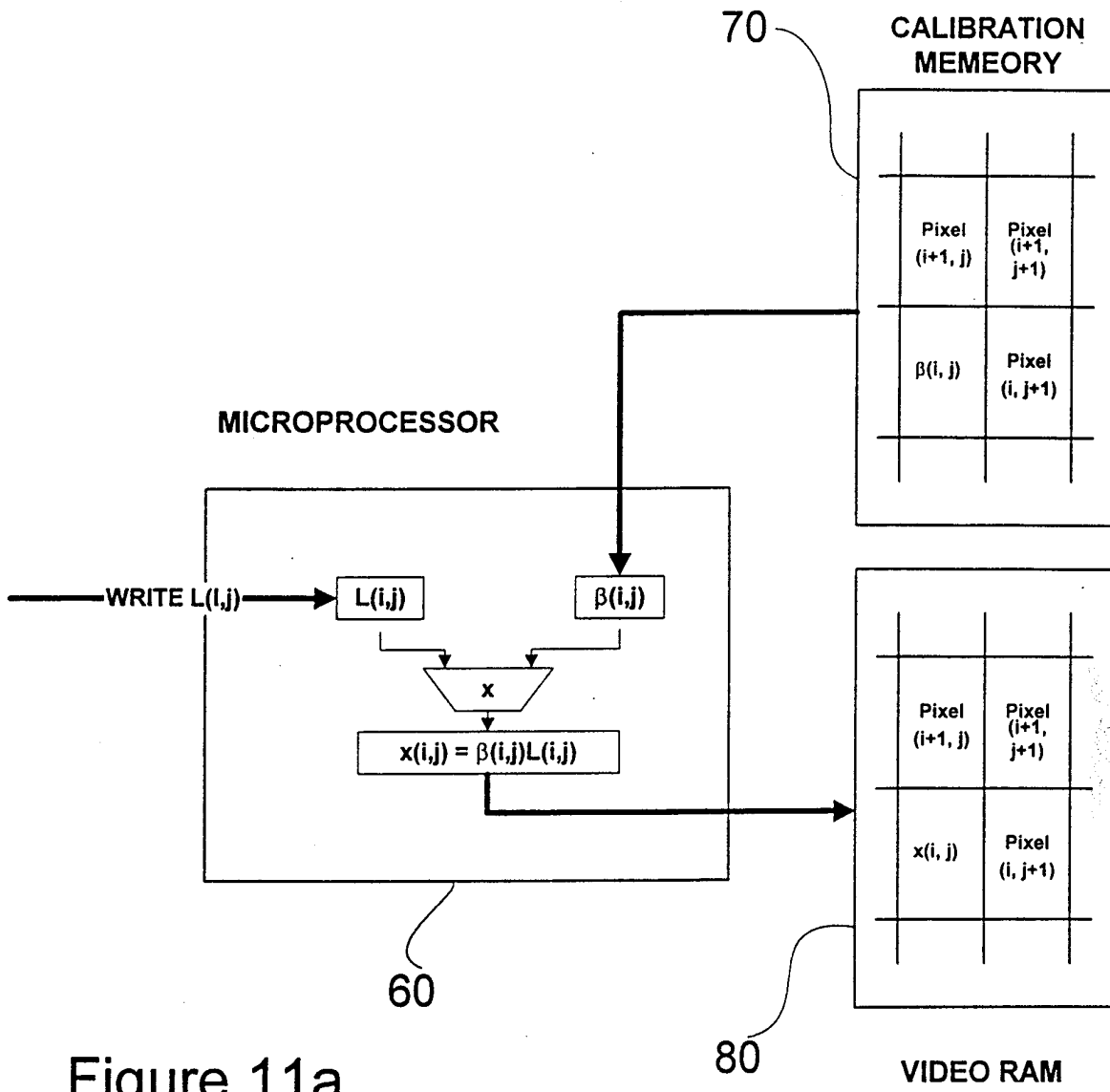

Figure 11a

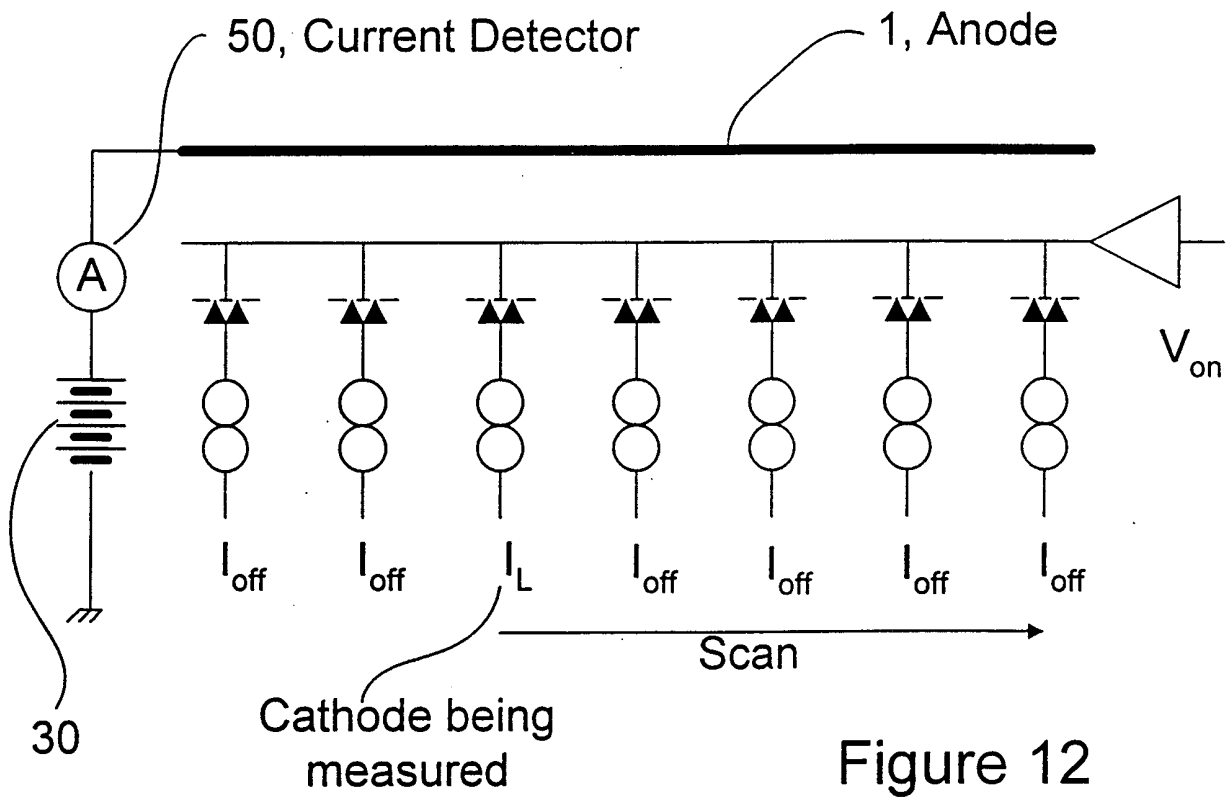

Figure 12

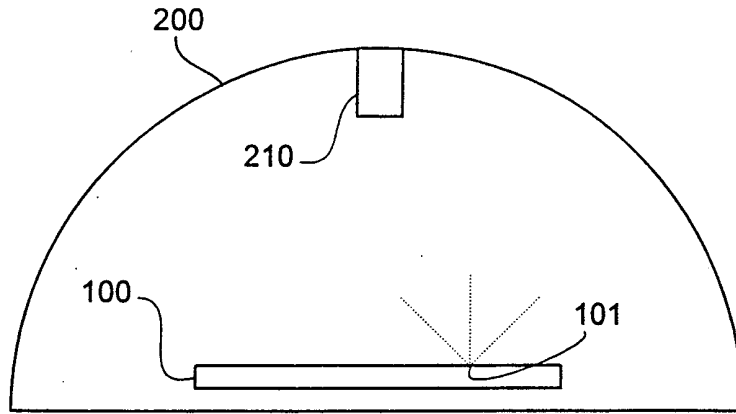

Figure 13

INTERNATIONAL SEARCH REPORT

International Application No

PCT/US 98/18599

C.(Continuation) DOCUMENTS CONSIDERED TO BE RELEVANT

Category °	Citation of document, with indication, where appropriate, of the relevant passages	Relevant to claim No.
X	<p>FR 2 683 365 A (RAYTHEON CO) 7 May 1993</p> <p>see abstract; figures 4-11 see page 3, line 25 - page 4, line 19 see page 27, line 15 - page 35, line 32</p>	<p>1-3, 6, 9, 10, 14-21, 26-30, 35, 36</p>
A	<p>EP 0 803 892 A (CANON KK) 29 October 1997</p> <p>see abstract; figures 1-13 see column 13, line 6 - column 15, line 21 see column 18, line 24 - column 21, line 58</p>	<p>1-36</p>
A	<p>EP 0 686 993 A (CANON KK) 13 December 1995</p> <p>see abstract; figure 8 see page 4, line 16 - page 4, line 43</p>	<p>1-36</p>
A	<p>EP 0 661 726 A (CANON KK) 5 July 1995</p> <p>see abstract; figure 1 see column 11, line 36 - column 8, line 53</p>	<p>1-36</p>

INTERNATIONAL SEARCH REPORT

information on patent family members

International Application No

PCT/US 98/18599

Patent document cited in search report	A	Publication date	Patent family member(s)	Publication date
EP 0755042	A	22-01-1997	US 5708451 A	13-01-1998
FR 2683365	A	07-05-1993	US 5262698 A JP 5249913 A	16-11-1993 28-09-1993
EP 0803892	A	29-10-1997	JP 10228867 A	25-08-1998
EP 0686993	A	13-12-1995	JP 8248920 A AT 173356 T AU 2054995 A CA 2151202 A CN 1125893 A DE 69505890 D JP 8248921 A US 5734361 A	27-09-1996 15-11-1998 04-01-1996 09-12-1995 03-07-1996 17-12-1996 27-09-1996 31-03-1998
EP 0661726	A	05-07-1995	JP 7181911 A JP 8160883 A AT 177560 T AU 681724 B AU 8162494 A CA 2138363 A CN 1108801 A US 5659328 A	21-07-1995 21-06-1996 15-03-1999 04-09-1997 13-07-1995 23-06-1995 20-09-1995 19-08-1997