

(19)



(11)

**EP 4 176 944 B1**

(12)

**EUROPEAN PATENT SPECIFICATION**

(45) Date of publication and mention of the grant of the patent:  
**02.07.2025 Bulletin 2025/27**

(51) International Patent Classification (IPC):  
**A63C 5/06 (2006.01) A63C 11/00 (2006.01)**

(21) Application number: **22204076.8**

(52) Cooperative Patent Classification (CPC):  
**A63C 5/06; A63C 11/003; A63C 2203/12; A63C 2203/18; A63C 2203/22; A63C 2203/24**

(22) Date of filing: **27.10.2022**

(54) **TELEMETRY SYSTEM FOR THE MOVEMENT ANALYSIS OF A DOWNHILL SKI DURING USE**

TELEMETRIESYSTEM ZUR BEWEGUNGSANALYSE EINES ABFAHRTSKIS WÄHREND DES GEBRAUCHS

SYSTÈME DE TÉLÉMÉTRIE POUR L'ANALYSE DE MOUVEMENT D'UN SKI DE DESCENTE EN COURS D'UTILISATION

(84) Designated Contracting States:  
**AL AT BE BG CH CY CZ DE DK EE ES FI FR GB GR HR HU IE IS IT LI LT LU LV MC ME MK MT NL NO PL PT RO RS SE SI SK SM TR**

(72) Inventor: **SANGIORGI, Gustavo**  
**39100 Bolzano (IT)**

(30) Priority: **28.10.2021 IT 202100027707**

(74) Representative: **Studio Torta S.p.A.**  
**Via Viotti, 9**  
**10121 Torino (IT)**

(43) Date of publication of application:  
**10.05.2023 Bulletin 2023/19**

(56) References cited:  
**US-A1- 2018 361 221 US-B1- 6 924 764**  
**US-B2- 7 433 805**

(73) Proprietor: **BLUE BIESSE S.R.L. CON SOCIO UNICO**  
**39100 Bolzano (IT)**

**EP 4 176 944 B1**

Note: Within nine months of the publication of the mention of the grant of the European patent in the European Patent Bulletin, any person may give notice to the European Patent Office of opposition to that patent, in accordance with the Implementing Regulations. Notice of opposition shall not be deemed to have been filed until the opposition fee has been paid. (Art. 99(1) European Patent Convention).

**Description**CROSS-REFERENCE TO RELATED APPLICATIONS

**[0001]** This patent application claims priority from Italian patent application no. 102021000027707 filed on 28 October 2021, the entire disclosure of which is incorporated herein by reference.

TECHNICAL FIELD

**[0002]** The present invention relates to a telemetry system for the movement analysis of a downhill ski during use.

**[0003]** More in detail, the present invention relates to a telemetry system for the real-time movement analysis of a downhill ski during a ski race, a use to which the following disclosure will make explicit reference without thereby losing generality.

BACKGROUND ART

**[0004]** As is known, during ski races, ski athletes go down one at a time along the ski slope where the sport competition takes place, and the ski athlete who travels along said slope in the shortest time wins.

**[0005]** To date, the only information available about the ski athlete's sports performance during the ski race is the total time taken to travel along the slope to the finish line, and the various split times detected at predetermined points on the slope.

**[0006]** US7433805B2 discloses a system for monitoring and quantifying sport movements, which is particularly useful in sporting activities such as skiing, snowboarding etc..

SUMMARY

**[0007]** Aim of the present invention is to provide a simple and inexpensive detection system, easily and quickly installable, which is capable of detecting in real time, during the ski athlete's descent along the ski slope and for each participant in the ski race, a series of physical quantities relative to the ski fitted during the descent.

**[0008]** According to these aims, according to the present invention there is provided a telemetry system for the real-time movement analysis of a downhill ski during use as defined in Claim 1 and preferably, though not necessarily, in any one of the dependent claims.

BRIEF DESCRIPTION OF THE DRAWINGS

**[0009]** The present invention will now be described with reference to the appended drawings, which illustrate a non-limiting embodiment thereof, wherein:

- Figure 1 is a schematic view of a remote detection

system for a downhill ski realized according to the teachings of the present invention, with transparent parts and parts removed for clarity's sake;

- Figure 2 is a section view of the downhill ski shown in Figure 1; whereas
- Figure 3 is a schematic view of the electronics mounted on the downhill ski shown in Figures 1 and 2, with parts removed for clarity's sake.

10 DESCRIPTION OF EMBODIMENTS

**[0010]** With reference to Figures 1 and 2, number 1 denotes, as a whole, a telemetry system for the real-time movement analysis of a downhill ski, which is configured so as to be able to measure, in real time, a series of physical quantities relative to the downhill ski during use, i.e. during the descent along a ski slope.

**[0011]** In addition, the telemetry system 1 can be advantageously used to analyze a ski athlete's performance during a ski race, i.e. while the ski athlete descends with the skis along the ski slope where the sports competition is taking place.

**[0012]** Preferably, the physical quantities measured moreover include the acceleration to which the ski is subjected and/or the inclination of the ski with respect to a predetermined inertial reference, in both cases measured in real time during the descent along the ski slope.

**[0013]** In more detail, the physical quantities measured preferably include the acceleration along the roll and/or pitch and/or yaw axes to which the ski is subjected during the descent along the ski slope, and/or the values of the roll angle and/or pitch angle and/or yaw angle of the ski during the descent along the ski slope.

**[0014]** Preferably, the physical quantities measured furthermore include the geographic position of the ski (namely the values of latitude, longitude and altitude) and/or the value of the ambient temperature around the ski during the descent along the ski slope.

**[0015]** The telemetry system 1 comprises at least one and more conveniently a plurality of mobile detection units 2, and a remote electronic apparatus 4 which is capable of communicating with each of the detection units 2.

**[0016]** In more detail, each detection unit 2 is adapted to be rigidly attached onto a generic downhill ski 3 so as to form, with the latter, a single sport equipment 5 capable of sliding over snow and/or ice.

**[0017]** In addition, each detection unit 2 is structured so as to be able to measure, continuously or cyclically, the values of a series of physical quantities, which include the momentary acceleration to which the detection unit 2 is subjected and/or the momentary inclination of the detection unit 2 with respect to a predetermined inertial reference.

**[0018]** When firmly attached to the ski 3, each detection unit 2 is therefore capable of measuring/sampling the momentary acceleration and/or inclination of the ski 3 while it is used to descend along any ski slope.

**[0019]** The remote electronic apparatus 4, in turn, is structured to wirelessly communicate with each of the detection units 2, so as to receive, preferably in real time, a data stream containing the measurements performed by each detection unit 2, and is also provided with a user interface that is configured to display, and optionally also reprocess and/or compare, the values indicative of the physical quantities separately measured by each mobile detection unit 2.

**[0020]** Preferably, the user interface of the remote electronic apparatus 4 is moreover programmed/configured so as to also reconstruct and display the time course of at least one and more conveniently all of the physical quantities measured by each mobile detection unit 2.

**[0021]** In more detail, each detection unit 2 is preferably structured so as to measure, continuously or at more or less regular intervals, the value of the acceleration to which the detection unit 2 is subjected along a first triplet of Cartesian reference axes. In addition or alternatively, each detection unit 2 is preferably structured so as to measure, continuously or at more or less regular intervals, the value of the inclination of the detection unit 2 with respect to a second triplet of Cartesian reference axes, preferably stationary in space.

**[0022]** Preferably, each detection unit 2 is moreover adapted to be attached onto the ski 3 so that one of the Cartesian axes of the first triplet of Cartesian reference axes is substantially parallel to the longitudinal axis of the ski 3.

**[0023]** In addition, one of the axes of said second triplet of Cartesian reference axes is preferably substantially vertical.

**[0024]** Therefore, each mobile detection unit 2 is preferably structured so that it can measure, continuously or at more or less regular intervals, the value of the acceleration to which the ski 3 is subjected along the axes of roll, pitch and yaw of the ski, and/or the values of the roll angle and/or pitch angle and/or yaw angle of the ski.

**[0025]** Preferably, each detection unit 2 is moreover structured so as to determine, continuously or at more or less regular intervals, its geographic position (namely the values of longitude, latitude and altitude).

**[0026]** Optionally, each detection unit 2 is finally structured so as to measure, continuously or at more or less regular intervals, the value of the ambient temperature around the same detection unit 2.

**[0027]** When the detection unit 2 is firmly attached to the ski 3 and the ski 3 is used to descend along the slope, the telemetry system 1 is therefore capable of also acquiring the momentary geographic position of the ski 3 and/or the instantaneous values of the ambient temperature around the ski 3.

**[0028]** In addition, each detection unit 2 is moreover structured/ configured to be uniquely identifiable by the remote electronic apparatus 4, so that the sports equipment 5 formed by the detection unit 2 and the ski 3 can be uniquely linked with an individual skier/athlete.

**[0029]** With reference to Figures 1 and 2, in particular, each mobile detection unit 2 preferably has a plate-like structure and is preferably adapted to be firmly attached onto the back 3a of the ski 3.

**[0030]** In more detail, each detection unit 2 is preferably adapted to be attached onto the back 3b of the downhill ski 3 in a rigid and stable, though easily removable manner.

**[0031]** In addition, each detection unit 2 is preferably structured so as to be attached onto the back 3a of the downhill ski 3, more or less in the center of the ski 3, so as to form the raised anchoring base where the ski binding device (not shown) is to be attached.

**[0032]** In other words, the detection unit 2 preferably has an oblong plate-like structure and is adapted to be firmly attached onto the back 3a of the ski 3, more or less in the center of the ski, so as to interpose itself between the downhill ski 3 and the relative ski binding device (not shown).

**[0033]** In more detail, with reference to Figures 1, 2 and 3, each detection unit 2 preferably comprises: a rigid outer casing 6, which is preferably made of plastic and/or composite material, and is adapted to be firmly fixed onto the back 3a of the ski 3, preferably by one or more anchoring screws of known type (not shown); a detection and data-transmission electronic device 7, which is housed within the rigid casing 6, and is adapted to measure and wirelessly transmit the values of the physical quantities listed above directly to the remote electronic apparatus 4; and an electric energy accumulator 8 preferably of a rechargeable and/or removable type, which is housed within the rigid casing 6 and powers the detection and data-transmission electronic device 7.

**[0034]** In the example shown, in particular, the rigid casing 6 is preferably made up of two rigid and complementary-shaped half-shells that are preferably made of plastic material and are firmly coupled together preferably substantially in a fluid-tight manner. Clearly, the two half-shells may also be made of metal or composite material.

**[0035]** The detection and data-transmission electronic device 7, in turn, preferably includes: a measurement module 9 that is structured so as to measure, continuously or at more or less regular intervals, the values of the physical quantities listed above; a data transmission module 10 that is structured so as to wirelessly transmit a data stream to the remote electronic apparatus 4; and a microprocessor 11 that controls and coordinates the operation of the measurement module 9 and of the data transmission module 10, so as to measure and send, preferably in real time, a data stream containing the various measurements performed by the measurement module 9, directly to the remote electronic apparatus 4.

**[0036]** Preferably, the detection and data-transmission electronic device 7 additionally comprises also: a main memory module 12, preferably of an immovable type, within which the microprocessor 11 can temporarily and/or stably store all or part of the data stream generated

by the measurement module 9, i.e. all or part of the sequence of measurements performed by the measurement module 9; and optionally also an auxiliary memory module 13 of a removable/extractable type, within which the microprocessor 11 can temporarily and/or stably store all or part of the data stream generated by the measurement module 9, i.e. all or part of the sequence of measurements performed by the measurement module 9.

**[0037]** Preferably, the detection and data-transmission electronic device 7 is finally also provided with a display device and/or a control panel (not shown in the figures), which is/are located outside of the rigid casing 6 or are easily accessible from the outside, and preferably allow a person, respectively, to check the status of and issue commands to the detection and data-transmission electronic device 7.

**[0038]** In the example shown, in particular, the detection and data-transmission electronic device 7 is preferably provided with a series of signaling LEDs and/or control buttons, that allow a person, respectively, to check the status of and issue commands to the detection and data-transmission electronic device 7.

**[0039]** With reference to Figure 3, the measurement module 9, in turn, is provided with an acceleration electronic measuring device 14 and/or an inclination electronic measuring device 15.

**[0040]** The acceleration electronic measuring device 14 is adapted to measure the value of the acceleration to which the detection unit 2 is subjected, and preferably includes one or more accelerometers capable of measuring, in real time, the acceleration along predetermined directions.

**[0041]** On the other hand, the inclination electronic measuring device 15 is adapted to measure the value of the inclination of the detection unit 2 with respect to a predetermined inertial reference, and preferably includes one or more inclinometers capable of measuring, in real time, the inclination with respect to said predetermined reference.

**[0042]** In addition or alternatively to the inclinometer(s), the inclination electronic measuring device 15 may also include at least one electronic gyroscope and/or at least one magnetometer, both capable of determine, in real time, the orientation in space of the mobile detection unit 2.

**[0043]** In more detail, in the example shown the acceleration electronic measuring device 14 preferably comprises a group of accelerometers, which are located within the rigid casing 6 one orthogonal to the other, so as to measure the acceleration of the detection unit 2 along a first triplet of Cartesian reference axes that is preferably oriented so that one of the Cartesian reference axes is substantially parallel to the longitudinal axis of the downhill ski 3 when the detection unit 2 is integral with the ski 3.

**[0044]** In other words, the acceleration electronic measuring device 14 is capable of measuring the acceleration

to which the detection unit 2 is subjected along the roll, pitch and yaw axes of the ski.

**[0045]** In addition, the accelerometer(s) of the acceleration electronic measuring device 14 are preferably MEMS accelerometer sensors (acronym for Micro Electro-Mechanical Systems).

**[0046]** The inclination electronic measuring device 15, in turn, is capable of measuring the inclination of detection unit 2 with respect to a second triplet of fixed Cartesian reference axes X, Y and Z, which is preferably oriented so that one of its Cartesian reference axes, namely the Cartesian axis Z, is substantially vertical.

**[0047]** The inclination electronic measuring device 15 is therefore capable of measuring, in real time, the instantaneous roll, pitch and yaw angles of the ski.

**[0048]** In more detail, in the example shown the inclination electronic measuring device 15 preferably comprises: a group of inclinometers that are placed within the rigid casing 6 one orthogonal to the other, so as to detect the inclination of detection unit 2 with respect to a triplet of Cartesian reference axes; and an electronic gyroscope which is adapted to detect the orientation in the space of the mobile detection unit 2.

**[0049]** In addition, the inclinometer(s) and/or the electronic gyroscope are preferably MEMS sensors (acronym for Micro Electro-Mechanical Systems).

**[0050]** With reference to Figure 3, preferably the measurement module 9 moreover includes also a GPS receiver 16 (acronym for Global Positioning System) or similar, which is adapted to receive radio signals coming from a series of artificial satellites orbiting the earth, and to process said radio signals so as to calculate/determine, substantially in real time, the momentary geographic position (or rather the geographic coordinates) and possibly also the longitudinal, transversal and vertical speed of the detection unit 2.

**[0051]** The GPS receiver 16 is an electronic component readily available on the market and therefore won't be further described.

**[0052]** Optionally, the measurement module 9 is finally also provided with one or more temperature sensors (not shown in the figures), which are capable of measuring the ambient temperature outside the rigid casing 6, around the detection unit 2.

**[0053]** Similarly to the GPS receiver 16, also the data transmission module 10 is an electronic component readily available on the market and therefore won't be further described, unless to point out that it is capable of wirelessly transmitting data to the remote electronic apparatus 4, preferably using the IEEE 802.11 standard (traditionally called the Wi-Fi standard) and/or the IEEE 802.16 standard (traditionally called the WiMAX standard) and/or the Bluetooth standard, or similar.

**[0054]** With reference to Figure 1, on the other hand the remote electronic apparatus 4 preferably comprises: one or more stationary transceiver units 17 that are placed or may be placed in proximity to or along the ski slope, i.e. in proximity to or along the race course, so as to be able to

receive radio signals emitted by the various mobile detection units 2 preferably, though not necessarily, without interruptions along the entire ski slope, i.e. the race course; and one or more fixed or portable computers 18 that are electronically connected to the stationary transceiver unit(s) 17 so as to receive the data coming from the individual detection units 2, and are provided with a user interface that is configured to display, preferably in real time, the values of the physical quantities measured by each mobile detection unit 2.

**[0055]** In more detail, the user interface of the computer(s) 18 is preferably programmed/configured so as to select, based on a command given by the user, a mobile detection unit 2 among those momentarily connected/available, and then to display the values of the physical quantities measured by said mobile detection unit 2.

**[0056]** In other words, the user interface of the computer(s) 18 is programmed/configured so as to identify each mobile detection unit 2 and then display, preferably in real time, the values of the physical quantities measured by said mobile detection unit 2.

**[0057]** Preferably, the user interface of the computer(s) 18 is moreover programmed/configured so as to reconstruct the time course of the values of at least one and, more conveniently, all of the physical quantities measured by each mobile detection unit 2, and/or the trajectory followed by each detection unit 2 as the ski 3 descends along the ski slope.

**[0058]** Optionally, the user interface of the computer(s) 18 is finally programmed/configured so as to also link the instantaneous values of at least one and, more conveniently, all the physical quantities measured by the various mobile detection units 2, with the geographic position where the same values were measured.

**[0059]** Operation of the telemetry system 1 is easily inferable from what has been described above.

**[0060]** During a ski race, as the ski athlete descends along the ski slope, the detection unit 2 attached onto one of the athlete's skis 3 continuously measures the acceleration and inclination of the ski 3, the ambient temperature around the skis 3, transmitting the measured values directly to the remote electronic apparatus 4.

**[0061]** In addition, during the descent along the ski slope, the detection unit 2 moreover continuously transmits the geographic position of the detection unit 2 to the remote electronic apparatus 4, so as to allow the remote electronic apparatus 4 to reconstruct the trajectory followed by the athlete/skier along the ski slope.

**[0062]** The advantages connected with the telemetry system 1 are clear.

**[0063]** Firstly, the telemetry system 1 allows to analyze and evaluate, in real time, the ski athlete's performance during the ski race without applying electronic devices directly on the athlete's body.

**[0064]** In addition, the telemetry system 1 is easily transportable and therefore can be quickly set up on the race course in conjunction with the ski race.

**[0065]** It is finally clear that modifications and varia-

tions may be made to the telemetry system 1 and its components without thereby departing from the scope of the present invention.

**[0066]** For example, the mobile detection units 2 may be structured to be at least partially embedded in the downhill ski 3.

**[0067]** In addition, in a more sophisticated not-shown embodiment, the signaling LED(s) of the detection and data-transmission electronic device 7 may be replaced by a TFT display or the like.

**[0068]** Finally, the data transmission module 10 of the detection and data-transmission electronic device 7 may communicate wirelessly with the remote electronic apparatus 4 by using UMTS and/or LTE standards and the cellular telephone network.

**[0069]** In this case, the stationary transceiver unit(s) 17 of the remote electronic apparatus 4 would consist of the transceiver station(s) of the cellular telephone network that are closest to the ski slope.

## Claims

1. A telemetry system (1) for the movement analysis of a downhill ski during use, which **comprises**: at least one mobile detection unit (2) which is adapted to be attached on the downhill ski (3), and is adapted to measure, continuously or cyclically, a series of physical quantities that include momentary acceleration and/or inclination of the detection unit (2); and a remote electronic apparatus (4) that communicates wirelessly with said detection unit (2) so as to receive a data stream containing the measurements carried out by each detection unit (2), and is moreover provided with a user interface that is configured so as to display values indicative of the physical quantities measured by said mobile detection unit (2); said telemetry system (1) being **characterised in that** said mobile detection unit (2) has a plate-like structure and is adapted to be attached onto the back (3b) of said ski (3), so as to form the raised anchoring base where the ski binding device is to be attached.
2. The telemetry system according to Claim 1, **characterised by** comprising a plurality of mobile detection units (2), each of which is adapted to be attached onto a respective downhill ski (3) and is uniquely identifiable by said remote electronic apparatus (4).
3. The telemetry system according to Claim 1 or 2, wherein the/each mobile detection unit (2) comprises: a rigid outer casing (6) that is adapted to be firmly fixed on the ski (3); a detection and data-transmission electronic device (7) which is housed within said rigid casing (6), and is adapted to measure and transmit the values of said physical quantities wirelessly directly to the remote electronic apparatus (4); and an electric energy accumulator (8)

which is housed within said rigid casing (6) and powers the detection and data-transmission electronic device (7).

4. The telemetry system according to Claim 3, wherein said detection and data-transmission electronic device (7) comprises an acceleration electronic measuring device (14) and/or an inclination electronic measuring device (15).
5. The telemetry system according to Claim 4, wherein the acceleration electronic measuring device (14) comprises a plurality of accelerometers adapted to measure the acceleration value of the mobile detection unit (2) with respect to a first triplet of Cartesian reference axes.
6. The telemetry system according to Claim 4 or 5, wherein the inclination electronic measuring device (15) comprises a plurality of inclinometers adapted to measure the value of the inclination of the detection unit (2) with respect to a second triplet of Cartesian reference axes (X, Y, Z), and/or an electronic gyroscope or magnetometer adapted to determine the orientation in space of the mobile detection unit (2).
7. The telemetry system according to Claim 3, 4, 5 or 6, wherein said detection and data-transmission electronic device (7) moreover comprises a GPS receiver (16) and/or one or more temperature sensors capable of measuring the ambient temperature around the mobile detection unit (2).
8. The telemetry system according to any one of the preceding claims, wherein the user interface of said remote electronic apparatus (4) is programmed/configured to additionally reconstruct and display the time course of one or more of said physical quantities.
9. The telemetry system according to any one of the preceding claims, wherein said remote electronic apparatus (4) comprises: one or more stationary transceiver units (17), which are placed or placeable in proximity to or along the ski slope, so as to receive the radio signals emitted by said mobile detection unit (s) (2); and one or more computers (18) that are electronically connected to the stationary transceiver unit(s) (17), so as to receive the data coming from said mobile detection unit(s) (2), and are provided with said user interface configured to display the values indicative of physical quantities measured by said mobile detection unit(s) (2).
10. The telemetry system according to Claim 9, wherein said user interface is additionally configured to select, based on a user command a mobile detection unit (2) among those available, and then display the

values of physical quantities measured by said mobile detection unit (2).

11. The telemetry system according to Claim 8 or 9, wherein said user interface is configured so as to reconstruct the trajectory followed by each detection unit (2) as the ski (3) descends along the ski slope.
12. The telemetry system according to Claim 9, 10 or 11, wherein said user interface is configured so as to link the instantaneous values of one or more of said physical quantities with the geographic position at which said values were measured.
13. Sport equipment (5) for sliding over snow and ice comprising a downhill ski (3) and **characterised by** also comprising a mobile detection unit (2), which is firmly attached on the back (3a) of said downhill ski (3) and is made according to any one of Claims 1 to 12.

#### Patentansprüche

1. Telemetriesystem (1) für die Bewegungsanalyse eines Abfahrtsskis während des Gebrauchs, das **umfasst:** mindestens eine mobile Erfassungseinheit (2), die angepasst ist, um an dem Abfahrtsski (3) angebracht zu werden, und angepasst ist, um kontinuierlich oder zyklisch eine Reihe von physikalischen Größen zu messen, die eine momentane Beschleunigung und/oder Neigung der Erfassungseinheit (2) beinhalten; und ein entferntes elektronisches Gerät (4), das drahtlos mit der Erfassungseinheit (2) kommuniziert, um einen Datenstrom zu empfangen, der die von jeder Erfassungseinheit (2) durchgeführten Messungen enthält, und darüber hinaus mit einer Benutzerschnittstelle versehen ist, die konfiguriert ist, um Werte anzuzeigen, die die von der mobilen Erfassungseinheit (2) gemessenen physikalischen Größen angeben; wobei das Telemetriesystem (1) **dadurch gekennzeichnet ist, dass** die mobile Erfassungseinheit (2) eine plattenartige Struktur aufweist und angepasst ist, um an der Rückseite (3b) des Skis (3) angebracht zu werden, um die erhöhte Verankerungsbasis zu bilden, an der die Skibindungsvorrichtung angebracht werden soll.
2. Telemetriesystem nach Anspruch 1, **dadurch gekennzeichnet, dass** es eine Vielzahl von mobilen Erfassungseinheiten (2) umfasst, von denen jede angepasst ist, um an einem jeweiligen Abfahrtsski (3) angebracht zu werden, und durch das entfernte elektronische Gerät (4) eindeutig identifizierbar ist.
3. Telemetriesystem nach Anspruch 1 oder 2, wobei die/jede mobile Erfassungseinheit (2) umfasst: ein

- starres Außengehäuse (6), das dazu angepasst ist, fest an dem Ski (3) befestigt zu werden; eine elektronische Erfassungs- und Datenübertragungsvorrichtung (7), die in dem starren Gehäuse (6) untergebracht ist und dazu angepasst ist, die Werte der physikalischen Größen zu messen und sie drahtlos direkt an das entfernte elektronische Gerät (4) zu übertragen; und einen elektrischen Energiespeicher (8), der in dem starren Gehäuse (6) untergebracht ist und die elektronische Erfassungs- und Datenübertragungsvorrichtung (7) mit Strom versorgt.
4. Telemetriesystem nach Anspruch 3, wobei die elektronische Erfassungs- und Datenübertragungsvorrichtung (7) eine elektronische Beschleunigungsmessvorrichtung (14) und/oder eine elektronische Neigungsmessvorrichtung (15) umfasst.
  5. Telemetriesystem nach Anspruch 4, wobei die elektronische Beschleunigungsmessvorrichtung (14) eine Vielzahl von Beschleunigungsmessern umfasst, die angepasst sind, um den Beschleunigungswert der mobilen Erfassungseinheit (2) in Bezug auf eine erste Triade von kartesischen Referenzachsen zu messen.
  6. Telemetriesystem nach Anspruch 4 oder 5, wobei die elektronische Neigungsmessvorrichtung (15) eine Vielzahl von Neigungsmessern umfasst, die angepasst sind, um den Wert der Neigung der Erfassungseinheit (2) in Bezug auf eine zweite Triade von kartesischen Referenzachsen (X, Y, Z) zu messen, und/oder ein elektronisches Gyroskop oder Magnetometer, das angepasst ist, um die Orientierung im Raum der mobilen Erfassungseinheit (2) zu bestimmen.
  7. Telemetriesystem nach Anspruch 3, 4, 5 oder 6, wobei die elektronische Erfassungs- und Datenübertragungsvorrichtung (7) ferner einen GPS-Empfänger (16) und/oder einen oder mehrere Temperatursensoren umfasst, die in der Lage sind, die Umgebungstemperatur um die mobile Erfassungseinheit (2) herum zu messen.
  8. Telemetriesystem nach einem der vorhergehenden Ansprüche, wobei die Benutzerschnittstelle des entfernten elektronischen Geräts (4) so programmiert/konfiguriert ist, dass es zusätzlich den Zeitverlauf einer oder mehrerer der physikalischen Größen rekonstruiert und anzeigt.
  9. Telemetriesystem nach einem der vorhergehenden Ansprüche, wobei das entfernte elektronische Gerät (4) umfasst: eine oder mehrere stationäre Sende-Empfangs-Einheiten (17), die in der Nähe oder entlang der Skipiste platziert oder platzierbar sind, um die von der/den mobilen Erfassungseinheit(en) (2) ausgesendeten Funksignale zu empfangen; und einen oder mehrere Computer (18), die elektronisch mit der/den stationären Sende-Empfangs-Einheit(en) (17) verbunden sind, um die von der/den mobilen Erfassungseinheit(en) (2) kommenden Daten zu empfangen, und die mit der Benutzerschnittstelle versehen sind, die so konfiguriert ist, dass sie die Werte anzeigt, die die von der/den mobilen Erfassungseinheit(en) (2) gemessenen physikalischen Größen angeben.
  10. Telemetriesystem nach Anspruch 9, wobei die Benutzerschnittstelle zusätzlich so konfiguriert ist, dass sie auf der Grundlage eines Benutzerbefehls eine mobile Erfassungseinheit (2) unter den verfügbaren auswählt und dann die Werte der von der mobilen Erfassungseinheit (2) gemessenen physikalischen Größen anzeigt.
  11. Telemetriesystem nach Anspruch 8 oder 9, wobei die Benutzerschnittstelle so konfiguriert ist, dass sie die von jeder Erfassungseinheit (2) verfolgte Trajektorie rekonstruiert, während der Ski (3) die Skipiste entlang nach unten fährt.
  12. Telemetriesystem nach Anspruch 9, 10 oder 11, wobei die Benutzerschnittstelle so konfiguriert ist, dass sie die Momentanwerte einer oder mehrerer der physikalischen Größen mit der geografischen Position verknüpft, an der die Werte gemessen wurden.
  13. Sportgerät (5) zum Gleiten auf Schnee und Eis, umfassend einen Abfahrtsski (3) und **dadurch gekennzeichnet, dass** es auch eine mobile Erfassungseinheit (2) umfasst, die fest an der Rückseite (3a) des Abfahrtsskis (3) angebracht ist und nach einem der Ansprüche 1 bis 12 hergestellt ist.

## Revendications

1. Système de télémétrie (1) pour l'analyse du déplacement d'un ski de descente pendant son utilisation, qui **comprend** : au moins une unité de détection mobile (2) qui est adaptée pour être fixée sur le ski de descente (3), et qui est adaptée pour mesurer, de manière continue ou cyclique, une série de quantités physiques qui comprennent l'accélération et/ou l'inclinaison momentanée de l'unité de détection (2) ; et un appareil électronique à distance (4) qui communique sans fil avec ladite unité de détection (2) de manière à recevoir un flux de données contenant les mesures effectuées par chaque unité de détection (2), et qui est en outre doté d'une interface utilisateur configurée de manière à afficher des valeurs indicatives des quantités physiques mesurées par ladite unité de détection mobile (2) ;

- ledit système de télémétrie (1) étant **caractérisé en ce que** ladite unité de détection mobile (2) a une structure en forme de plaque et est adaptée pour être fixée à l'arrière (3b) dudit ski (3), de manière à former la base d'ancrage surélevée où le dispositif de fixation du ski doit être fixé.
2. Système de télémétrie selon la revendication 1, **caractérisé par le fait qu'il** comprend plusieurs unités de détection mobiles (2), chacune étant adaptée pour être fixée sur un ski de descente respectif (3) et étant identifiable de manière unique par l'appareil électronique à distance (4).
  3. Système de télémétrie selon la revendication 1 ou 2, dans lequel l'unité de détection mobile (2) comprend : un boîtier extérieur rigide (6) adapté pour être fermement fixé sur le ski (3) ; un dispositif électronique de détection et de transmission de données (7) logé dans ledit boîtier rigide (6) et adapté pour mesurer et transmettre sans fil les valeurs des quantités physiques directement à l'appareil électronique à distance (4) ; et un accumulateur d'énergie électrique (8) logé dans ledit boîtier rigide (6) et alimentant le dispositif électronique de détection et de transmission de données (7).
  4. Système de télémétrie selon la revendication 3, dans lequel ledit dispositif électronique de détection et de transmission de données (7) comprend un dispositif électronique de mesure de l'accélération (14) et/ou un dispositif électronique de mesure de l'inclinaison (15).
  5. Système de télémétrie selon la revendication 4, dans lequel le dispositif électronique de mesure de l'accélération (14) comprend une pluralité d'accéléromètres adaptés pour mesurer la valeur de l'accélération de l'unité de détection mobile (2) par rapport à un premier triplet d'axes de référence cartésiens.
  6. Système de télémétrie selon la revendication 4 ou 5, dans lequel le dispositif électronique de mesure de l'inclinaison (15) comprend une pluralité d'inclinomètres adaptés pour mesurer la valeur de l'inclinaison de l'unité de détection (2) par rapport à un deuxième triplet d'axes cartésiens de référence (X, Y, Z), et/ou un gyroscope électronique ou un magnétomètre adapté pour déterminer l'orientation dans l'espace de l'unité de détection mobile (2).
  7. Système de télémétrie selon la revendication 3, 4, 5 ou 6, dans lequel ledit dispositif électronique de détection et de transmission de données (7) comprend en outre un récepteur GPS (16) et/ou un ou plusieurs capteurs de température capables de mesurer la température ambiante autour de l'unité de détection mobile (2).
  8. Système de télémétrie selon l'une des revendications précédentes, dans lequel l'interface utilisateur de l'appareil électronique à distance (4) est programmée/configurée pour reconstruire et afficher en outre l'évolution temporelle d'une ou de plusieurs de ces quantités physiques.
  9. Système de télémétrie selon l'une des revendications précédentes, dans lequel l'appareil électronique à distance (4) comprend : une ou plusieurs unités émettrices-réceptrices stationnaires (17), qui sont placées ou peuvent être placées à proximité ou le long de la piste de ski, de manière à recevoir les signaux radio émis par ladite ou lesdites unités de détection mobiles (2) ; et un ou plusieurs ordinateurs (18) qui sont connectés électroniquement à la ou aux unités émettrices-réceptrices stationnaires (17), de manière à recevoir les données provenant de ladite ou desdites unités de détection mobiles (2), et qui sont dotés de ladite interface utilisateur configurée pour afficher les valeurs indicatives des quantités physiques mesurées par ladite ou lesdites unités de détection mobiles (2).
  10. Système de télémétrie selon la revendication 9, dans lequel ladite interface utilisateur est en outre configurée pour sélectionner, sur la base d'une commande de l'utilisateur, une unité de détection mobile (2) parmi celles qui sont disponibles, puis afficher les valeurs des quantités physiques mesurées par ladite unité de détection mobile (2).
  11. Système de télémétrie selon la revendication 8 ou 9, dans lequel l'interface utilisateur est configurée pour reconstruire la trajectoire suivie par chaque unité de détection (2) lors de la descente du ski (3) le long de la piste de ski.
  12. Système de télémétrie selon la revendication 9, 10 ou 11, dans lequel ladite interface utilisateur est configurée de manière à relier les valeurs instantanées d'une ou de plusieurs de ces quantités physiques à la position géographique à laquelle ces valeurs ont été mesurées.
  13. Équipement de sport (5) pour glisser sur la neige et la glace comprenant un ski de descente (3) et **caractérisé par** comprenant également une unité de détection mobile (2), qui est fermement fixée à l'arrière (3a) dudit ski de descente (3) et est fabriqué selon l'une quelconque des revendications 1 à 12.

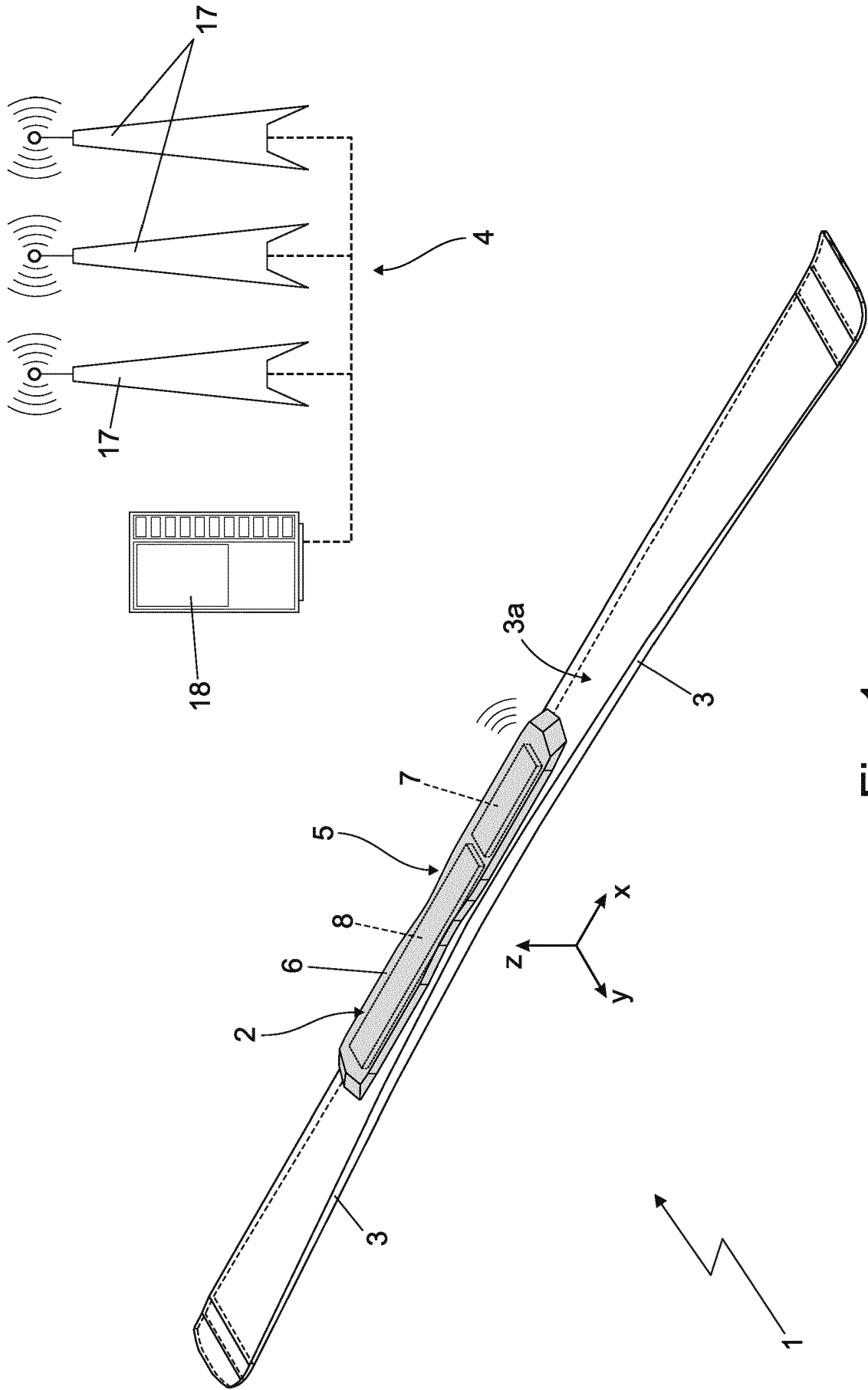

Fig. 1

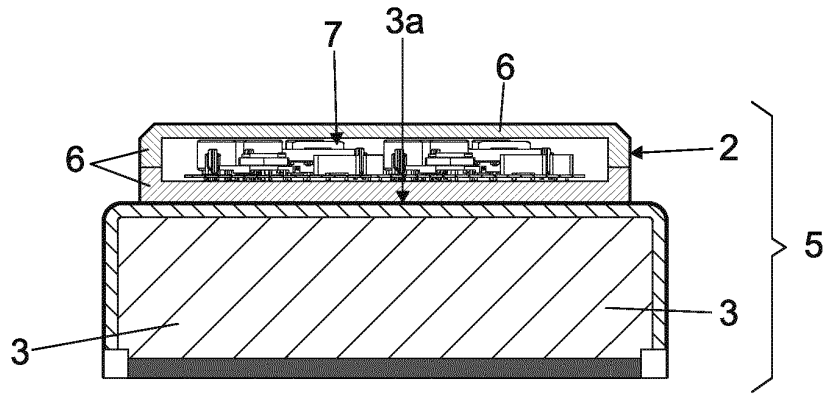

Fig. 2

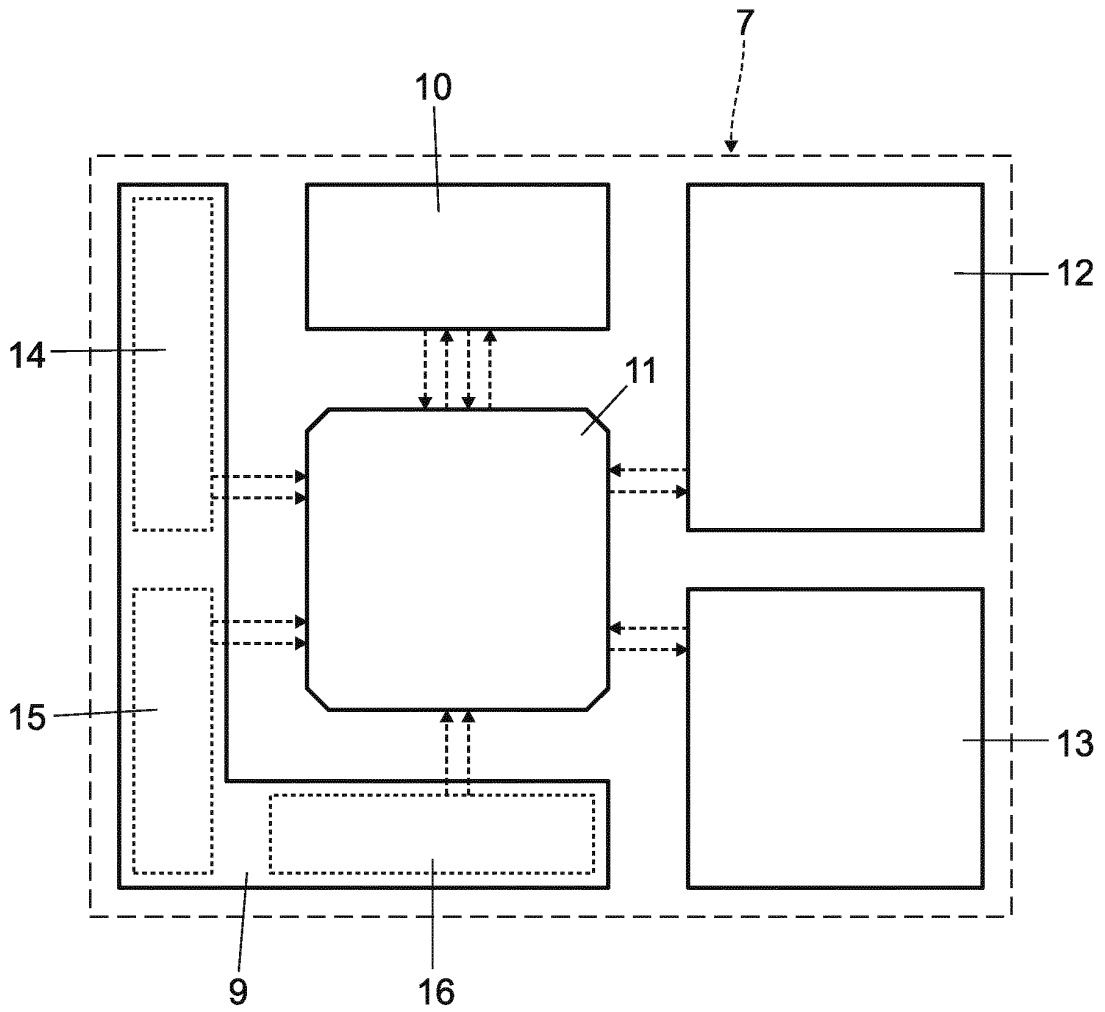

Fig. 3

**REFERENCES CITED IN THE DESCRIPTION**

*This list of references cited by the applicant is for the reader's convenience only. It does not form part of the European patent document. Even though great care has been taken in compiling the references, errors or omissions cannot be excluded and the EPO disclaims all liability in this regard.*

**Patent documents cited in the description**

- IT 102021000027707 [0001]
- US 7433805 B2 [0006]