

(19) World Intellectual Property Organization  
International Bureau



(43) International Publication Date  
20 September 2007 (20.09.2007)

PCT

(10) International Publication Number  
**WO 2007/104967 A1**

- (51) International Patent Classification:  
*B05B 7/06* (2006.01)      *B05B 7/08* (2006.01)
- (21) International Application Number:  
PCT/GB2007/000871
- (22) International Filing Date: 14 March 2007 (14.03.2007)
- (25) Filing Language: English
- (26) Publication Language: English
- (30) Priority Data:  
0605105.6      14 March 2006 (14.03.2006)      GB
- (71) Applicant (for all designated States except US): **BWI PLC** [GB/GB]; Kitling Road, Knowsley Business Park, Prescote, Merseyside L34 9JS (GB).

AT, AU, AZ, BA, BB, BG, BR, BW, BY, BZ, CA, CH, CN, CO, CR, CU, CZ, DE, DK, DM, DZ, EC, EE, EG, ES, FI, GB, GD, GE, GH, GM, GT, HN, HR, HU, ID, IL, IN, IS, JP, KE, KG, KM, KN, KP, KR, KZ, LA, LC, LK, LR, LS, LT, LU, LY, MA, MD, MG, MK, MN, MW, MX, MY, MZ, NA, NG, NI, NO, NZ, OM, PG, PH, PL, PT, RO, RS, RU, SC, SD, SE, SG, SK, SL, SM, SV, SY, TJ, TM, TN, TR, TT, TZ, UA, UG, US, UZ, VC, VN, ZA, ZM, ZW.

(84) Designated States (unless otherwise indicated, for every kind of regional protection available): ARIPO (BW, GH, GM, KE, LS, MW, MZ, NA, SD, SL, SZ, TZ, UG, ZM, ZW), Eurasian (AM, AZ, BY, KG, KZ, MD, RU, TJ, TM), European (AT, BE, BG, CH, CY, CZ, DE, DK, EE, ES, FI, FR, GB, GR, HU, IE, IS, IT, LT, LU, LV, MC, MT, NL, PL, PT, RO, SE, SI, SK, TR), OAPI (BF, BJ, CF, CG, CI, CM, GA, GN, GQ, GW, ML, MR, NE, SN, TD, TG).

- (72) Inventor; and
- (75) Inventor/Applicant (for US only): **LYON, Barry** [GB/GB]; 66 Twickenham Drive, Huyton, Merseyside L36 4QG (GB).
- (74) Agent: **MARKS & CLERK**; Tower Building, Water Street, Liverpool L3 1BA (GB).
- (81) Designated States (unless otherwise indicated, for every kind of national protection available): AE, AG, AL, AM,

**Published:**  
— with international search report  
— before the expiration of the time limit for amending the claims and to be republished in the event of receipt of amendments

For two-letter codes and other abbreviations, refer to the "Guidance Notes on Codes and Abbreviations" appearing at the beginning of each regular issue of the PCT Gazette.

(54) Title: SPRAY GUN HEADS

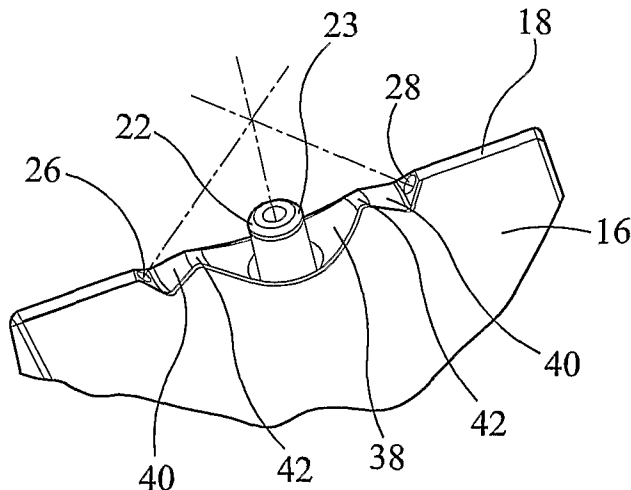

(57) Abstract: A spray head for a multiple fluid atomiser spray gun has a spray delivery face (18) has a main fluid delivery nozzle (22) and one or more atomising fluid delivery orifices (26, 28) associated therewith, wherein the spray delivery face is shaped to cause the droplets of said main fluid to be driven away from the spray delivery face by atomising fluid from the atomising fluid delivery orifice or orifices (26, 28) .

WO 2007/104967 A1

Title: Spray gun heads

## DESCRIPTION

This invention relates to spray gun heads.

Multiple fluid atomiser spray guns are used for spraying fluid solutions in the food, agricultural, pharmaceutical and similar industries. Such spray guns generally have a spray delivery head that has a central nozzle for say a coating fluid, an orifice for introducing atomising air to the fluid to produce a spray plume and additional orifices for air to control the pattern of spray plume.

In one known nozzle arrangement the atomising air orifice is an annulus surrounding a projecting fluid delivery nozzle and control fluid orifices are provided either side of the central nozzle in angled faces of the spray head, so that the central nozzle is in a trough.

A drawback with this arrangement is that there is a tendency for droplets of the fluid to fall back and adhere to surfaces of the nozzle body, which is known as bearding. This droplet build up continues whilst spraying leading to a loss in nozzle performance including blockage. Furthermore, the build up of droplets can solidify and break off and fall into and contaminate the process. This results from the presence of low-pressure zones adjacent to the outlet orifices due to the sudden geometrical enlargement, through which the escaping air is emitted. These low-pressure zones generate recirculating eddy currents in the air flow, which entrain fluid droplets and deliver them onto the local external faces of the spray head adjacent to the orifices and annulus. Over time these droplets stick to each other forming the undesirable build up mainly in the nozzle region.

It has been proposed to make the face of a spray gun nozzle completely flat but this does not prevent bearding.

An object of this invention is to provide a spray nozzle for a multiple fluid spray gun, which at least reduces the effect of bearding.

According to a first aspect of the invention a spray head for a multiple fluid atomiser spray gun has a spray delivery face having a main fluid delivery nozzle and an atomising fluid delivery orifice associated therewith, wherein the spray delivery face is shaped to cause droplets of said main fluid to be driven away from the spray delivery face by atomising fluid from the atomising fluid delivery orifice.

Preferably the atomising fluid delivery orifice is an annular orifice around the main fluid delivery nozzle. More preferably the main fluid delivery nozzle projects beyond the annular orifice.

The spray delivery face outwardly of and adjacent to the atomising fluid delivery orifice preferably is at an angle of less than  $90^\circ$  to the axis of the orifice.

According to a second aspect of the invention a spray head for a multiple fluid atomiser spray gun has a spray delivery face having an atomised fluid delivery system and one or more orifices for delivery of fluid to control the spray pattern, wherein the spray delivery face is shaped to cause droplets of said main fluid to be driven away from the spray delivery face by spray pattern controlling fluid.

Preferably the or each spray pattern controlling fluid delivery orifice has an axis at the angle to deliver its fluid across the first fluid spray.

More preferably the spray delivery face inwards of the or each spray pattern controlling fluid orifice is at an angle of less than  $90^\circ$  to the axis of the orifice.

Preferably the atomised fluid delivery system of the second aspect of the invention is an atomising fluid delivery system of the first aspect of the invention.

The spray head preferably has a generally circular base and a pair of opposed sides sloping towards to the spray delivery face. The spray head preferably has a generally central passage leading to the main fluid delivery nozzle and the associated atomising fluid delivery nozzle. Preferably the or each spray pattern controlling fluid delivery orifice is supplied through its own bore. Where more than one spray pattern controlling fluid delivery orifice is provided, their bores may be interconnected such as by means of an annular passage.

In a preferred embodiment of the invention the main fluid delivery nozzle is surrounded by an annular atomising fluid delivery orifice and the surrounding spray delivery face is in the form of a dish. Preferably at opposing ends of the dish the delivery face slopes down to a spray pattern controlling fluid delivery orifice.

Spray heads of the invention are preferably made of metal or of plastics material may be served to a spray gun by means of a locking collar or nut.

This invention will now be further described, by way of example only, with reference to the accompanying drawings, in which:

Figure 1 is a side view of a spray nozzle according to the invention;

Figure 2 is a plan view of the spray nozzle of Figure 1;

Figure 3 is a section on line AA of Figure 2;

Figure 4 shows the spray nozzle of Figure 1 from above the side;

Figure 5 is a sectional view of the spray nozzle of Figure 1 showing spray patterns;

Figure 6 is another side view of the spray nozzle of Figure 1;

Figure 7 is a view from below and one side of the spray nozzle of Figure 1; and

Figure 8 is an end view of the spray nozzle of Figure 1.

Referring to the accompanying drawings, a spray head 10 for a multiple fluid atomiser spray gun has a body 12 having a circular base 14 for mounting on a spray gun apparatus and sloping faces 16 leading to a narrow spray delivery face 18.

The body 12 has a central passage 20 for delivery of coating fluid to a delivery nozzle 22 end part only and for delivery of atomising fluid through an annular orifice 24 surrounding the main fluid delivery nozzle. The nozzle 22 for the coating fluid protrudes beyond the spray face 18, which enables interaction of air and fluid streams beyond the spray face helping to inhibit atomised fluid droplets being picked up by air currents in the vicinity of the face. At the tip of the nozzle 22 its outer edge is chamfered at 23 to reduce a low pressure zone at the nozzle tip. Figure 5 of the drawings shows the zone of low pressure at 25. By contrast a conventional nozzle has a generally square tip, which creates a larger low pressure zone at the nozzle tip. On opposite sides of the delivery nozzle are spray pattern controlling fluid delivery orifices 26, 28, whose axes are inclined relative to the axis of the coating fluid delivery nozzle 22. The orifices 26, 28 are served by bores 30, 32 respectively, which are interconnected via an annular channel 34 in the base of the spray head. Annular wall 36, which separates the passage 20 from the channel 34 serves to locate the spray head relative to the spray gun apparatus. The spray head may be of metal or plastics material.

Through the spray head a coating fluid is delivered via the nozzle 22 and air delivered through the annular orifice 24 atomises the coating fluid to create a spray

plume, which is generally conical in shape (see particularly Figure 5). However, the spray pattern controlling fluid orifices 26, 28 deliver air from either side of the coating fluid spray plume to change the shape of the spray plume to being of generally oval section in order to control the area of delivery of the coating fluid. Typically, the coating fluid is applied to tablets in the pharmaceutical industry.

The spray delivery face 18 is shaped in the region of the delivery nozzle 22 and the orifices 24, 26 and 28 in order to allow atomising air and spray pattern controlling air to drive droplets of main fluid from the region to inhibit bearding.

The part of the face surrounding the annular orifice is dish shaped (38) and at opposite ends of the dish the face 40 slopes down to the spray shaping fluid orifices at 26 and 28. Smooth transitions between the dish 38 at opposite ends and the respective slopes 40 are shown at 42. The sides of the dish 38 and the sloping faces 40 are generally at less than  $90^{\circ}$  to the axes of their respective orifices, so that the air from those orifices tends to drive any droplets of the coating fluid from the delivery face in the region of the nozzle and orifices.

More specifically, the spray face 18 of the spray head is so profiled in the region of the main coating fluid nozzle, atomising fluid annulus and spray pattern controlling orifices that the escaping air is provided with a gradual geometrical enlargement as defined by the dish 38, slopes 40 and smooth transitions 42. The effect of the gradual geometrical enlargement is a gradual air release (as opposed to a sudden release) in that the air does not form recirculating eddy currents and thus little or no entrapment of coating fluid droplets back onto the spray face occurs.

Figure 5 illustrates the atomising air plume 50 emitted from the annular orifice 24, the spray pattern controlling air plume 52 emitted from orifices 26 and 28 and the zone of interaction between both air plumes 50 and 52 to provide a combined air plume 54. The air streams shown as 50 and 52 keep the local external surfaces free from droplets, which would otherwise stick to the surfaces and cause bearding.

Broken line 56 represents the typical shape of existing nozzle designs. Considering the likely shape of the air plumes as they emerge from orifices 26 and 28 it is probable that a low pressure zone is created in the region between these orifices and the annular orifice, which generates recirculating eddy currents in the air-flow, which entrain small droplets back onto the spray face adjacent to the orifices 24, 26 and 28. The invention eliminates this low pressure zone with solid material as shown at 58, which then through geometrical form provides a gradual geometrical enlargement which has the effect of eliminating the recirculating eddy currents normally produced with a face shown by the line 56.

Figure 8 shows the sloping faces 16, which provide a path for spray plume replenishing air 60 to enter the vicinity of the orifices 24, 26 and 28 and replace air consumed by the air plumes 50 and 52. On existing designs shallow angled faces illustrated by line 62 do not allow replenishing air 60 to enter the vicinity of the atomising and pattern air outlets akin to orifices 24, 26 and 28 creating low-pressure zones that result in bearding.

## Claims:

1. A spray head for a multiple fluid atomiser spray gun has a spray delivery face having a main fluid delivery nozzle and an atomising fluid delivery orifice associated therewith, wherein the spray delivery face is shaped to cause droplets of said main fluid to be driven away from the spray delivery face by atomising fluid from the atomising fluid delivery orifice.
2. A spray head as claimed in claim 1, wherein the atomising fluid delivery orifice is an annular orifice around the main fluid delivery nozzle.
3. A spray head as claimed in claim 2, wherein the main fluid delivery nozzle projects beyond the annular orifice.
4. A spray head as claimed in claim 1, 2 or 3, wherein the spray delivery face outwardly of and adjacent to the atomising fluid delivery orifice is at an angle of less than  $90^{\circ}$  to the axis of the orifice.
5. A spray head as claimed in any one of claims 1 to 4 having one or more orifices for delivery of spray pattern controlling fluid to shape the atomised fluid spray.
6. A spray head as claimed in claim 5, wherein the spray delivery face is shaped to cause droplets of said main fluid to be driven away from the spray delivery face in the region of the spray pattern controlling fluid delivery orifice or orifices.
7. A spray head as claimed in claim 6, wherein the or each shaping fluid delivery orifice has an axis at an angle to deliver its fluid across the main fluid atomised spray.
8. A spray head as claimed in claim 6 or 7, wherein the spray delivery face inwards of the or each shaping fluid orifice is at an angle of less than  $90^{\circ}$  to the axis of the orifice.

9. A spray head as claimed in any one of claims 1 to 8 having a generally circular base and a pair of opposed sloping sides towards to the spray delivery face.
10. A spray head as claimed in any one of claims 1 to 9, having a generally central passage leading to the main fluid delivery nozzle and the associated atomising fluid delivery nozzle.
11. A spray head as claimed in any one of claims 5 to 10, wherein the or each spray pattern controlling fluid delivery orifices is supplied through its own bore.
12. A spray head as claimed in claim 11, wherein, where more than one spray pattern controlling fluid delivery orifice is provided, their bores are interconnected.
13. A spray head as claimed in claim 12, wherein the bores are interconnected by means of an annular passage.
14. A spray head as claimed in claim 1, wherein the main fluid delivery nozzle is surrounded by an annular atomising fluid delivery orifice and the surrounding spray delivery face is in the form of a dish.
15. A spray head as claimed in 14, wherein, at opposite ends of the dish, the delivery face slopes down to a spray pattern controlling fluid delivery orifice.
16. A spray head for a multiple atomiser fluid spray gun has a spray delivery face having an atomised fluid spray delivery system and one or more orifices for delivery of fluid to control the spray pattern, wherein the spray delivery face is shaped to cause droplets of said main fluid to be driven away from the spray delivery face by spray pattern controlling fluid
17. A spray head as claimed in claim 16, wherein the or each pattern controlling fluid delivery orifice has an axis at an angle to deliver its fluid across the main fluid spray.

18. A spray head as claimed in claim 17, wherein the spray delivery face inwards of the or each spray pattern controlling fluid orifice is at an angle of less than  $90^{\circ}$  to the axis of the orifice.
19. A spray head as claimed in claim 16, 17 or 18 having a generally circular base and a pair of opposed sides sloping towards to the spray delivery face.
20. A spray head as claimed in any one of claims 16 to 19, having a generally central passage leading to the main fluid delivery nozzle and the associated atomising fluid delivery nozzle.
21. A spray head as claimed in any one of claims 16 to 20, wherein the or each spray pattern controlling fluid delivery orifice is supplied through its own bore.
22. A spray head as claimed in claim 21, wherein, where more than one spray pattern controlling fluid delivery orifice is provided, their bores are interconnected.
23. A spray head as claimed in claim 22, wherein the bores are interconnected by means of an annular passage.
24. A spray head as claimed in claim 1, wherein the atomised fluid spray delivery system is surrounded by a spray delivery face in the form of a dish.
25. A spray head as claimed in 24, wherein, at opposite ends of the dish, the delivery face slopes down to a spray pattern controlling fluid delivery orifice.
26. A spray head for a multiple fluid atomiser spray gun substantially as hereinbefore described with reference to and as illustrated in the accompanying drawings

1 / 2

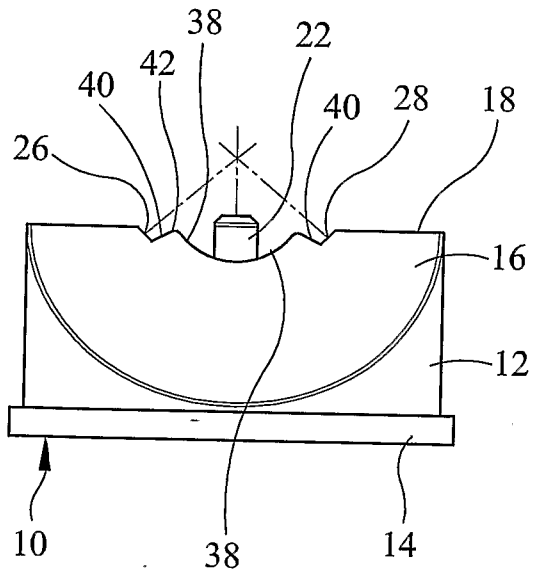

FIG 1

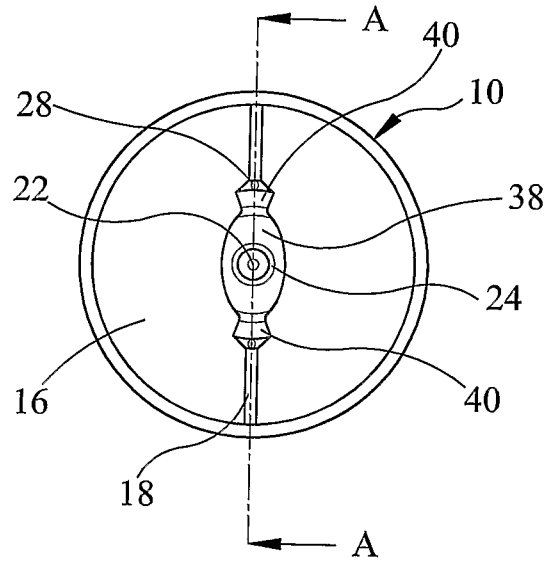

FIG 2

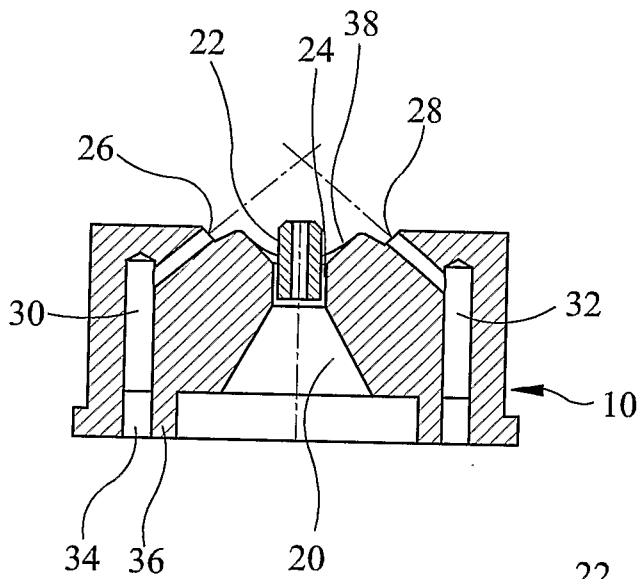

FIG 3

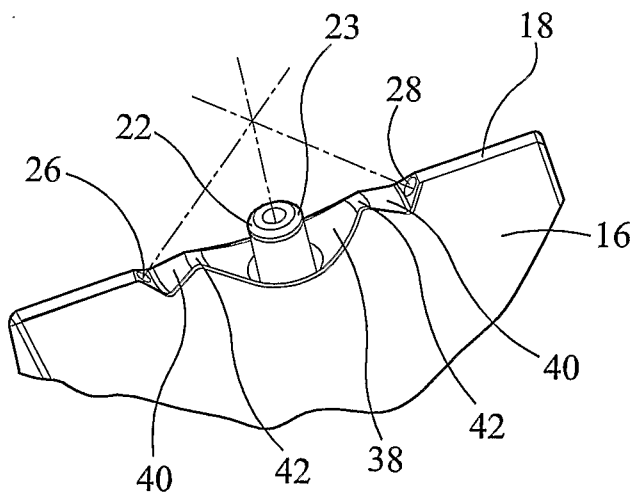

FIG 4

2 / 2

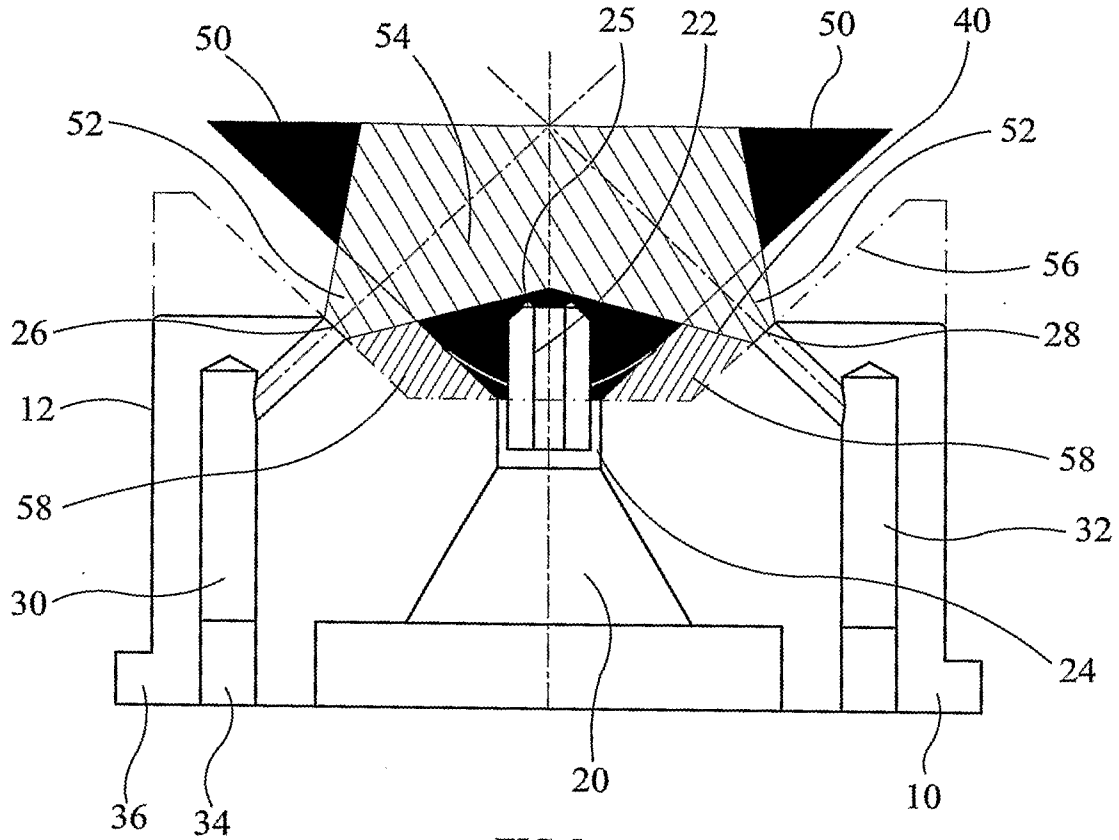

FIG 5

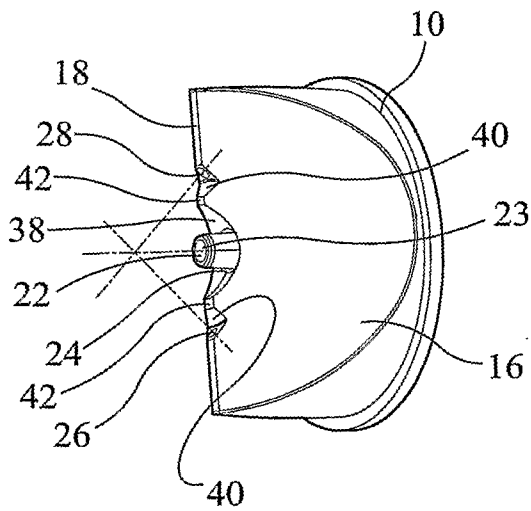

FIG 6

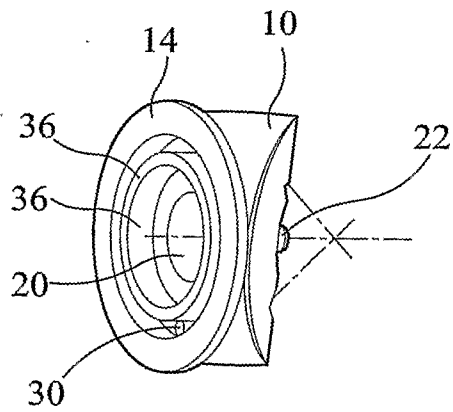

FIG 7

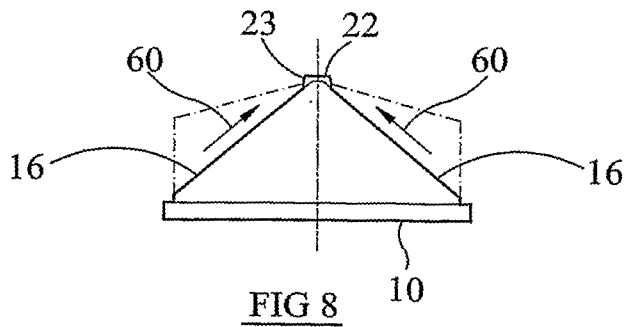

FIG 8

# INTERNATIONAL SEARCH REPORT

International application No  
PCT/GB2007/000871

<b>A. CLASSIFICATION OF SUBJECT MATTER</b> INV. B05B7/06 B05B7/08		
According to International Patent Classification (IPC) or to both national classification and IPC		
<b>B. FIELDS SEARCHED</b> Minimum documentation searched (classification system followed by classification symbols) B05B		
Documentation searched other than minimum documentation to the extent that such documents are included in the fields searched		
Electronic data base consulted during the international search (name of data base and, where practical, search terms used) EPO-Internal, WPI Data		
<b>C. DOCUMENTS CONSIDERED TO BE RELEVANT</b>		
Category*	Citation of document, with indication, where appropriate, of the relevant passages	Relevant to claim No.
X	US 6 494 387 B1 (KANEKO MASARU [JP]) 17 December 2002 (2002-12-17) column 4, line 25 - column 8, line 22; figures 3a,3b,6-8	1-3,5-25
A	-----	4
X	DE 29 24 174 A1 (HEINRICH BUEHNEN KG MASCHINENF) 18 December 1980 (1980-12-18) pages 6-7; figure 1	1-4
X	WO 03/051524 A (EMILSSON HAAKAN [SE]) 26 June 2003 (2003-06-26) page 3, line 16 - page 7, line 7; figures 1-4	1,2,5-25
	----- -/--	
<input checked="" type="checkbox"/> Further documents are listed in the continuation of Box C. <span style="margin-left: 200px;"><input checked="" type="checkbox"/> See patent family annex.</span>		
* Special categories of cited documents :		
*A* document defining the general state of the art which is not considered to be of particular relevance *E* earlier document but published on or after the international filing date *L* document which may throw doubts on priority claim(s) or which is cited to establish the publication date of another citation or other special reason (as specified) *O* document referring to an oral disclosure, use, exhibition or other means *P* document published prior to the international filing date but later than the priority date claimed	*T* later document published after the international filing date or priority date and not in conflict with the application but cited to understand the principle or theory underlying the invention *X* document of particular relevance; the claimed invention cannot be considered novel or cannot be considered to involve an inventive step when the document is taken alone *Y* document of particular relevance; the claimed invention cannot be considered to involve an inventive step when the document is combined with one or more other such documents, such combination being obvious to a person skilled in the art. *&* document member of the same patent family	
Date of the actual completion of the international search	Date of mailing of the international search report	
29 June 2007	11/07/2007	
Name and mailing address of the ISA/ European Patent Office, P.B. 5318 Patentlaan 2 NL - 2280 HV Rijswijk Tel. (+31-70) 340-2040, Tx. 31 651 epo nl, Fax: (+31-70) 340-3016	Authorized officer  Brito, Fernando	

## INTERNATIONAL SEARCH REPORT

International application No  
PCT/GB2007/000871

C(Continuation). DOCUMENTS CONSIDERED TO BE RELEVANT		
Category*	Citation of document, with indication, where appropriate, of the relevant passages	Relevant to claim No.
X	US 2005/173561 A1 (COTTER JOHN [CA] ET AL) 11 August 2005 (2005-08-11)  abstract; figure 3 -----	1,2, 5-14, 16-24
X	WO 2004/035222 A (SPRAYING SYSTEMS CO [US]; HUFFMAN DAVID C [US]) 29 April 2004 (2004-04-29) abstract; figure 5 -----	1-3,5-7, 9-13,16, 17,19-23
X,P	EP 1 745 854 A (WAGNER GMBH J [DE]) 24 January 2007 (2007-01-24)  paragraphs [0019] - [0023]; figures 1-7 -----	1,2,5-8, 10,11, 16-18, 20,21

# INTERNATIONAL SEARCH REPORT

Information on patent family members

International application No

PCT/GB2007/000871

Patent document cited in search report	Publication date	Patent family member(s)	Publication date
US 6494387	B1	17-12-2002	
		AU 4394399 A	22-01-2001
		DE 69928944 T2	07-09-2006
		EP 1108476 A1	20-06-2001
		WO 0102099 A1	11-01-2001
DE 2924174	A1	18-12-1980	NONE
WO 03051524	A	26-06-2003	
		AU 2002358383 A1	30-06-2003
		SE 524216 C2	13-07-2004
		SE 0104222 A	15-06-2003
US 2005173561	A1	11-08-2005	NONE
WO 2004035222	A	29-04-2004	
		AU 2003279969 A1	04-05-2004
EP 1745854	A	24-01-2007	
		DE 102005034519 A1	25-01-2007