

G. L. JECK.

SECTIONAL ARMATURE FOR DYNAMOS AND ELECTRIC MOTORS.

No. 580,977.

Patented Apr. 20, 1897.

Fig. 1.

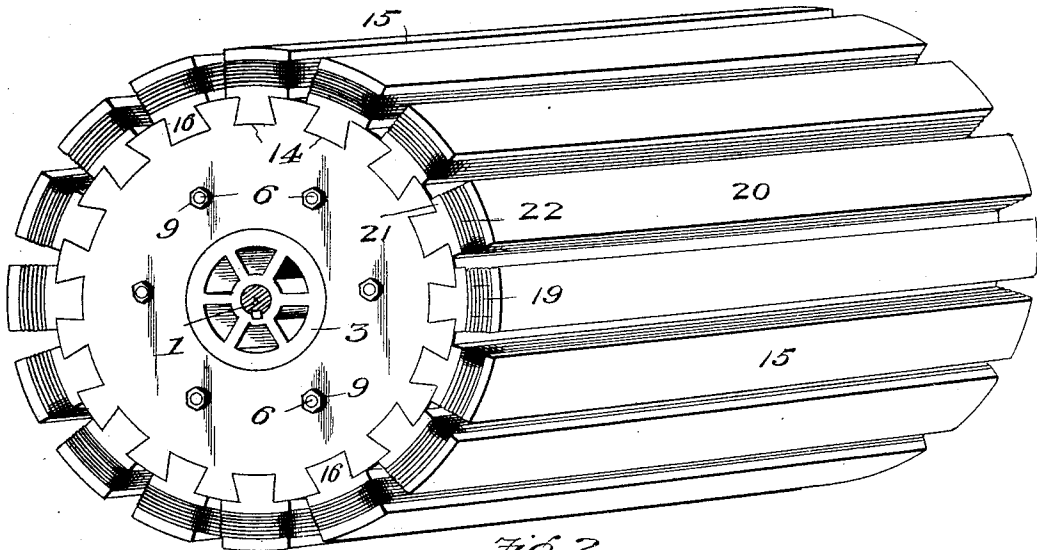
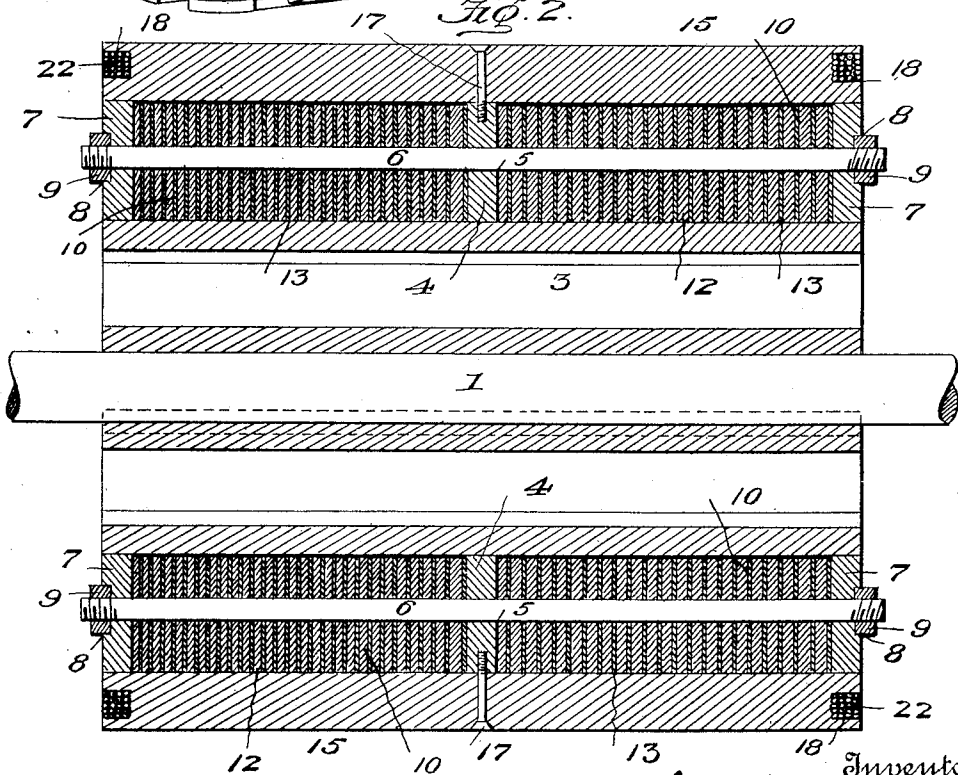

Fig. 2.



Witnesses
Wm. C. Ashieen
J. A. Hillson.

Inventor
Geo. L. Jeck.
 By *H. B. Wilson*
 Attorney

G. L. JECK.

SECTIONAL ARMATURE FOR DYNAMOS AND ELECTRIC MOTORS.

No. 580,977.

Patented Apr. 20, 1897.

Fig. 3.

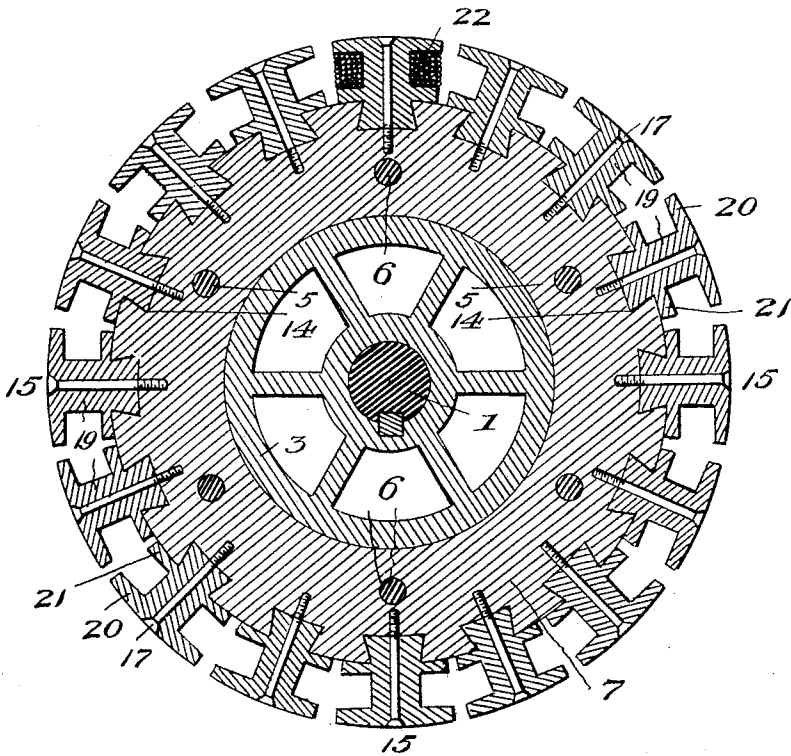

Fig. 4.

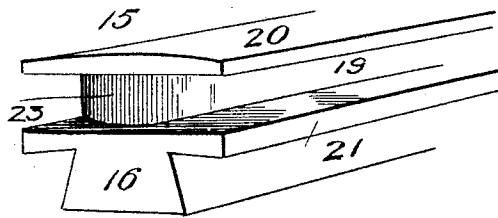
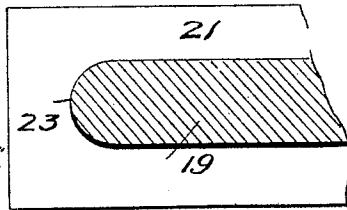

Fig. 5.



Witnesses
Wm. C. Washburn
J. A. Hillborn

Inventor
Geo. L. Jeck.
 By *H. B. Wilson.*
 Attorney

UNITED STATES PATENT OFFICE.

GEORGE LEONARD JECK, OF NASHVILLE, TENNESSEE.

SECTIONAL ARMATURE FOR DYNAMOS AND ELECTRIC MOTORS.

SPECIFICATION forming part of Letters Patent No. 580,977, dated April 20, 1897.

Application filed January 9, 1897. Serial No. 618,594. (No model.)

To all whom it may concern:

Be it known that I, GEORGE LEONARD JECK, a citizen of the United States, residing at Nashville, in the county of Davidson and State of Tennessee, have invented certain new and useful Improvements in Sectional Armatures for Dynamos and Electric Motors; and I do declare the following to be a full, clear, and exact description of the invention, such as will enable others skilled in the art to which it appertains to make and use the same.

My invention has relation to improvements in the construction of the sectional armatures for electric motors and dynamos; and the object is to simplify the same, so that a burned-out shuttle-coil may be readily replaced without taking apart or rewinding the entire armature.

A further object is to provide a series of interchangeable shuttle-sections, wound with wire of different gage and resistance, so that by removing one series of sections and replacing another series the machine may be changed from a dynamo to a motor at will.

To these ends the novelty consists in the construction, combination, and arrangement of the same, as will be hereinafter more fully described, and particularly pointed out in the claim.

In the accompanying drawings the same reference-numerals indicate the same parts of the invention.

Figure 1 is a perspective view of a sectional armature embodying my invention. Fig. 2 is a longitudinal section. Fig. 3 is a central transverse section. Fig. 4 is a detail perspective view of the end of one of the interchangeable shuttle-sections, and Fig. 5 is a detail horizontal section of the same.

1 represents the armature-shaft, to which is secured by a key a non-magnetic metal spider 3.

4 represents an annular cast-iron washer located midway longitudinally of the armature and provided with a series of orifices 5 for the reception of bolts 6. 7 7 represent similar cast-iron washers, also provided with orifices 5 for the bolts 6 and countersunk recesses 8 for the reception of the nuts 9.

10 10 represent the laminated core, com-

prising a series of annular sheet (Russia) iron rings 12, alternating with a series of correspondingly-shaped tissue-paper rings 13, the whole series of iron and paper rings being formed with bolt-holes alined with those in the cast-iron washers 4 and 7. By means of the bolts 6 and nuts 9 the washers and rings are firmly clamped together, forming a laminated core.

14 14 represent a series of longitudinal dovetail grooves arranged parallel to each other in the periphery of the washers and laminated core.

15 15 represent the "shuttle-shaped" interchangeable armatures, which are preferably formed of annealed high-grade Norway iron. Each armature 15 is formed in one piece with a longitudinal dovetail tongue 16, which snugly fits the corresponding grooves 14 in the periphery of the core.

17 represents a countersunk head-screw which passes radially through the center of each armature and engages a threaded orifice in the central washer 4 to removably secure the armatures in place in the grooves 14. These interchangeable armatures 15 are each formed with a longitudinal recess 18, extending entirely around its integral web 19, between the face-flange 20 and the base-flange 21, which receives the armature-wire 22, wound thereon shuttle-fashion, and the ends 23 23 of the web 19 are rounded or semicircular in form to dispense with sharp angles and form a smooth surface for the wire.

Although I have specifically described the construction and relative arrangement of the several elements of my invention I do not desire to be confined to the same, as such changes or modifications may be made as clearly fall within the scope of my invention without departing from the spirit thereof.

Having thus fully described my invention, what I claim as new and useful, and desire to secure by Letters Patent of the United States, is—

An interchangeable armature for dynamos and motors, comprising the non-magnetic metallic spider 3, the washers 4 and 7, the laminated core 10, and the binding bolts and nuts 6 and 9, the said washers and laminated

core being formed with longitudinal alined dovetail grooves 14, in combination with the interchangeable armature-section 15, formed with the longitudinal dovetail tongue 16, adapted to be removably secured in the dovetail grooves 14, substantially as and for the purpose set forth.

In testimony whereof I hereunto affix my signature in presence of two witnesses.

GEORGE LEONARD JECK.

Witnesses:

CLARENCE L. CHASE,
HOLMES DUFF.