

(12) INTERNATIONAL APPLICATION PUBLISHED UNDER THE PATENT COOPERATION TREATY (PCT)

(19) World Intellectual Property
Organization
International Bureau



(10) International Publication Number
WO 2023/275965 A1

(43) International Publication Date
05 January 2023 (05.01.2023)

WIPO | PCT

(51) International Patent Classification:

B29C 48/25 (2019.01) *B29B 7/48* (2006.01)
B29B 7/22 (2006.01) *B29B 7/58* (2006.01)

(21) International Application Number:

PCT/JP2021/024462

(22) International Filing Date:

29 June 2021 (29.06.2021)

(25) Filing Language:

English

(26) Publication Language:

English

(71) Applicant: **COMPAGNIE GENERALE DES
ETABLISSEMENTS MICHELIN** [FR/FR]; 23, Place des
Carmes-Dechaux, 63000 CLERMONT-FERRAND (FR).

(72) Inventors: **BUNSART Sarawut**; c/o NIHON MICHELIN
TIRE CO., LTD., Shinjuku Park Tower 13F, 3-7-1,
Nishi-Shinjuku, Shinjuku-ku, Tokyo, 1631073 (JP).
HWANSANG Akkamon; Michelin Siam Co., Ltd., 69
Moo4, Chalung, Hatyai, Songkhla 90110 (TH). **TREM-
BLIER Jerome**; Michelin Siam Co., Ltd., 69 Moo4,
Chalung, Hatyai, Songkhla 90110 (TH).

(74) Agent: **WADA Yukihiro**; NIHON MICHELIN TIRE CO.,
LTD., Shinjuku Park Tower 13F, 3-7-1, Nishi-Shinjuku,
Shinjuku-ku, Tokyo, 1631073 (JP).

(81) Designated States (*unless otherwise indicated, for every
kind of national protection available*): AE, AG, AL, AM,
AO, AT, AU, AZ, BA, BB, BG, BH, BN, BR, BW, BY, BZ,
CA, CH, CL, CN, CO, CR, CU, CZ, DE, DJ, DK, DM, DO,
DZ, EC, EE, EG, ES, FI, GB, GD, GE, GH, GM, GT, HN,
HR, HU, ID, IL, IN, IR, IS, IT, JO, JP, KE, KG, KH, KN,
KP, KR, KW, KZ, LA, LC, LK, LR, LS, LU, LY, MA, MD,
ME, MG, MK, MN, MW, MX, MY, MZ, NA, NG, NI, NO,
NZ, OM, PA, PE, PG, PH, PL, PT, QA, RO, RS, RU, RW,
SA, SC, SD, SE, SG, SK, SL, ST, SV, SY, TH, TJ, TM, TN,
TR, TT, TZ, UA, UG, US, UZ, VC, VN, WS, ZA, ZM, ZW.

(84) Designated States (*unless otherwise indicated, for every
kind of regional protection available*): ARIPO (BW, GH,
GM, KE, LR, LS, MW, MZ, NA, RW, SD, SL, ST, SZ, TZ,
UG, ZM, ZW), Eurasian (AM, AZ, BY, KG, KZ, RU, TJ,
TM), European (AL, AT, BE, BG, CH, CY, CZ, DE, DK,
EE, ES, FI, FR, GB, GR, HR, HU, IE, IS, IT, LT, LU, LV,
MC, MK, MT, NL, NO, PL, PT, RO, RS, SE, SI, SK, SM,
TR), OAPI (BF, BJ, CF, CG, CI, CM, GA, GN, GQ, GW,
KM, ML, MR, NE, SN, TD, TG).

Published:

— with international search report (Art. 21(3))

(54) Title: A SEALING DEVICE FOR A ROTOR SHAFT OF A KNEADER

(57) Abstract: A sealing device (123) for a rotor shaft (1) of a kneader; the rotor shaft (1) having a rotor shaft diameter (1D) and a rotation axis (1C); the sealing device (123) provided with a first visco seal (2) and a second visco seal (3) arranged closer to a discharge side end (5) of the rotor shaft (1) than the first visco seal (2).



WO 2023/275965 A1

Description

Title of Invention: A SEALING DEVICE FOR A ROTOR SHAFT OF A KNEADER

Technical Field

[0001] The field of the invention is that of a sealing device for a rotor shaft of a kneader.

Background

[0002] A kneader(s) for mixing a material(s) has been provided with a rotor shaft(s), and the kneader(s) has been additionally equipped with a sealing device(s) in order to prevent leak of material(s) to outside of a mixing chamber(s) of the kneader(s).

Citation List

Patent Literature

[0003] PTL 1: US5413475A

[0004] The patent literature 1 discloses a screw is inserted within a cylinder of an extruder, and in a base portion of the screw is formed a cooling bore, and between the base portion of the screw and the cylinder is disposed a first visco seal sleeve having multiple-start square threads on its inner circumference.

[0005] A constant objective of manufacturers using kneaders is to reduce the above leak.

Summary of Invention

Technical Problem

[0006] During the research, the inventors have discovered a specific sealing device (123) for a rotor shaft of a kneader, which allows an unexpectedly improved reduction of leak of mixing material.

Solution to Problem

[0007] The solution is a sealing device (123) for a rotor shaft (1) of a kneader, and the sealing device (123) provided with a first visco seal (2) and a second visco seal (3).

Advantageous Effects of Invention

[0008] The specific sealing device (123) for a rotor shaft of a kneader allows an unexpectedly improved reduction of leak of mixing material.

Brief Description of Drawings

[0009] [Fig.1]Fig. 1 shows a schematic view of a part (especially, a sealing device (123)) of a kneader cross sectional view according to this invention;
[Fig.2]Fig. 2 shows a schematic view of a sealing device (123) (especially, a first visco seal rotary portion (22)) cross sectional view according to this invention;
[Fig.3]Fig. 3 shows a schematic view of a sealing device (123) (especially, a second visco seal (3) provided with a second visco seal stationary portion (31) and a second

visco seal rotary portion (32)) cross sectional view according to this invention;
 [Fig.4]Fig. 4 shows a schematic view of a sealing device (123) (especially, a second visco seal rotary portion (32)) cross sectional view according to this invention;

Description of Embodiments

- [0010] Each of the below aspect(s), the embodiment(s), the instantiation(s), and the variant(s) including each of the preferred range(s), matter(s) or both may be applied to any one of the other aspect(s), the other embodiment(s), the other instantiation(s) and the other variant(s) of the invention unless expressly stated otherwise.
- [0011] Any interval of values denoted by the expression “between a and b” represents the range of values of more than “a” and of less than “b” (i.e. the limits a and b excluded) whereas any interval of values denoted by the expression “from a to b” means the range of values going from “a” to “b” (i.e. including the strict limits a and b).
- [0012] Figs.1, 2, 3 and 4 show a first aspect of the invention that is a sealing device (123) for a rotor shaft (1) of a kneader; the rotor shaft (1) having a rotor shaft diameter (1D) and a rotation axis (1C); the sealing device (123) provided with a first visco seal (2) and a second visco seal (3) arranged closer to a discharge side end (5) of the rotor shaft (1) than the first visco seal (2); the first visco seal (2) provided with a first visco seal stationary portion (21), a first visco seal rotary portion (22) rotating with the rotor shaft (1), and at least one first visco seal clearance (2122C) that is at least one distance from the first visco seal stationary portion (21) to the first visco seal rotary portion (22); the first visco seal rotary portion (22) having at least one first visco seal rotary portion helical groove (221) and at least one first visco seal rotary portion thread (222) formed on a radially outer circumferential surface of the first visco seal rotary portion (22); the first visco seal rotary portion helical groove (221) helically extending around the rotation axis (1C) of the rotor shaft (1); the first visco seal rotary portion thread (222) delimited via the first visco seal rotary portion helical groove (221); the second visco seal (3) provided with a second visco seal stationary portion (31), at least one second visco seal rotary portion (32) rotating with the rotor shaft (1), and at least one second visco seal clearance (3132C, 31243214C, 31243224C, 31143224C, 312453224C, 3124532145C, 312453225C, 31153225C, 31253225C, 31253215C) that is at least one distance from the second visco seal stationary portion (31) to the second visco seal rotary portion (32); the second visco seal rotary portion (32) having at least one second visco seal rotary portion helical groove (32241, 32251) and at least one second visco seal rotary portion thread (32242, 32252) formed on the radially outermost circumferential surface of the second visco seal rotary portion (32);
- the second visco seal rotary portion helical groove (32241, 32251) helically extending around the rotation axis (1C) of the rotor shaft (1); and

- the second visco seal rotary portion thread (32242, 32252) delimited via the second visco seal rotary portion helical groove (32241, 32251).

- [0013] According to a preferred embodiment of the invention, wherein the kneader is an equipment for kneading at least one of a plastic, a rubber or a combination thereof, or an agent and at least one of a plastic, a rubber or a combination thereof by a blade (1B) fixed with the rotor shaft of the kneader, preferably the agent is at least one of a filler agent, a coupling agent, a plasticizing agent, an antiaging agent, an antioxidant agent, a crosslinking agent or a combination thereof.
- [0014] According to a preferred embodiment of the invention, wherein the first visco seal stationary portion (21) is fixed with a housing (7) of the kneader, the second visco seal stationary portion (31) or both.
- [0015] According to a preferred embodiment of the invention, wherein the second visco seal stationary portion (31) is fixed with at least one of the housing (7) of the kneader, the first visco seal stationary portion (21) or both.
- [0016] According to a preferred embodiment of the invention, wherein the first visco seal rotary portion (22) is fixed with the rotor shaft (1), the second visco seal rotary portion (32) or both.
- [0017] According to a preferred embodiment of the invention, wherein the second visco seal rotary portion (32) is fixed with the rotor shaft (1), the first visco seal rotary portion (22) or both.
- [0018] The “radially” means “in a radial direction”, and the radial direction is a direction perpendicular to an axial direction that is a direction to parallel to the rotation axis (1C) of the rotor shaft (1).
- [0019] According to a preferred embodiment of the invention, wherein the second visco seal rotary portion convex part is a radially convex part in the second visco seal rotary portion (32).
- [0020] A second aspect of the invention is the sealing device (123) according to the first aspect, wherein the first visco seal rotary portion (22) has a first visco seal rotary portion diameter (22D) that is twice as long as a distance from the radially outermost of the first visco seal rotary portion (22) to the rotation axis (1C) of the rotor shaft (1), and wherein the second visco seal rotary portion (32) has a second visco seal rotary portion diameter (32D) that is twice as long as a distance from the radially outermost of the second visco seal rotary portion (32) to the rotation axis (1C) of the rotor shaft (1), preferably wherein the second visco seal rotary portion diameter (32D) is longer than the first visco seal rotary portion diameter (22D), more preferably wherein a ratio of the second visco seal rotary portion diameter (32D) to the first visco seal rotary portion diameter (22D) is between 100.0% and 150.0%, still more preferably between 105.0% and 140.0%, particularly between 110.0% and 130.0%. The ratio is 118.5% in

the present example shown in the Figs. That can make the sealing performance of the second visco seal (3) more efficient.

[0021] According to a preferred embodiment of the second aspect, wherein a ratio of the first visco seal rotary portion diameter (22D) to the rotor shaft diameter (1D) is between 100.0% and 150.0%, preferably between 100.0% and 140.0%, more preferably between 105.0% and 135.0%, still more preferably between 110.0% and 130.0%. That is for compromise between efficient sealing and prevention of over-heating. The ratio of the first visco seal rotary portion diameter (22D) to the rotor shaft diameter (1D) is 119.4% in the present example shown in the Figs.

[0022] According to a preferred embodiment of the second aspect, wherein a ratio of the second visco seal rotary portion diameter (32D) to the rotor shaft diameter (1D) is between 100% and 200.0%, preferably between 110.0% and 170.0%, more preferably between 120.0% and 160.0%, still more preferably between 130.0% and 150.0%. That is for compromise between efficient sealing and prevention of over-heating. The ratio of the second visco seal rotary portion diameter (32D) to the rotor shaft diameter (1D) is 142.0% in the present example shown in the Figs.

[0023] A third aspect of the invention is the sealing device (123) according to the first or the second aspect, wherein the first visco seal rotary portion (22) has a first visco seal rotary portion width (22W) in a direction parallel to the rotation axis (1C) of the rotor shaft (1), and wherein the second visco seal rotary portion (32) has a second visco seal rotary portion width (3224W, 3225W) in a direction parallel to the rotation axis (1C) of the rotor shaft (1), preferably wherein the second visco seal rotary portion width (3224W, 3225W) is shorter than the first visco seal rotary portion width (22W) (for prevention of over-heating), preferably wherein a ratio of the second visco seal rotary portion width (3224W, 3225W) to the first visco seal rotary portion width (22W) is between 5.0% and 20.0%, more preferably between 10.0% and 15.0%. That is for compromise between efficient sealing and prevention of over-heating. The ratio of the second visco seal rotary portion width (3224W, 3225W) to the first visco seal rotary portion width (22W) is 11.9% in the present example shown in the Figs.

[0024] According to a preferred embodiment of the third aspect, wherein a ratio of the first visco seal rotary portion width (22W) to the rotor shaft diameter (1D) is between 50.0% and 100.0%, preferably between 55.0% and 95.0%, more preferably between 60.0% and 90.0%, still more preferably between 65.0 and 85.0%, particularly between 70.0% and 75.0%. That is for compromise between efficient sealing and prevention of over-heating. The ratio of the first visco seal rotary portion width (22W) to the rotor shaft diameter (1D) is 74.3% in the present example shown in the Figs.

[0025] According to a preferred embodiment of the third aspect, wherein a ratio of the second visco seal rotary portion width (3224W, 3225W) to the rotor shaft diameter

(1D) is between 4.0% and 20.0%, preferably between 5.0% and 13.0%, more preferably between 6.0% and 12.0%, still more preferably between 7.0% and 11.0%. That is for compromise between efficient sealing and prevention of over-heating. The ratio of the second visco seal rotary portion width (3224W, 3225W) to the rotor shaft diameter (1D) is 8.8% in the present example shown in the Figs.

[0026] A fourth aspect of the invention is the sealing device (123) according to any one of the first to the third aspect, wherein the first visco seal rotary portion thread (222) has a first visco seal rotary portion thread height (222H) in a direction perpendicular to the rotation axis (1C) of the rotor shaft (1), and wherein the second visco seal rotary portion thread (32242, 32252) has a second visco seal rotary portion thread height (32242H, 32252H) in a direction perpendicular to the rotation axis (1C) of the rotor shaft (1), preferably wherein the second visco seal rotary portion thread height (32242H, 32252H) is shorter than the first visco seal rotary portion thread height (222H) (for prevention of over-heating), more preferably a ratio of the second visco seal rotary portion thread height (32242H, 32252H) to the first visco seal rotary portion thread height (222H) is between 60% and 100%, still more preferably between 65% and 95%, particularly between 70% and 90%, more particularly between 75% and 85%. That is for compromise between efficient sealing and prevention of over-heating. The ratio of the second visco seal rotary portion thread height (32242H, 32252H) to the first visco seal rotary portion thread height (222H) is 80.0% in the present example shown in the Figs.

[0027] According to a preferred embodiment of the fourth aspect, wherein a ratio of the first visco seal rotary portion thread height (222H) to the rotor shaft diameter (1D) is between 1.0% and 10.0%, preferably between 1.0% and 8.0%, more preferably between 1.0% and 6.0%, still more preferably between 2.0% and 4.0%. That is for compromise between efficient sealing and prevention of over-heating. The ratio of the first visco seal rotary portion thread height (222H) to the rotor shaft diameter (1D) is 3.3% in the present example shown in the Figs.

[0028] According to a preferred embodiment of the fourth aspect, wherein a ratio of the second visco seal rotary portion thread height (32242H, 32252H) to the rotor shaft diameter (1D) is between 1.0% and 10.0%, preferably between 1.0% and 7.0%, more preferably between 1.0% and 6.0%, still more preferably between 1.0% and 5.0%. That is for compromise between efficient sealing and prevention of over-heating. The ratio of the second visco seal rotary portion thread height (32242H, 32252H) to the rotor shaft diameter (1D) is 2.7% in the present example shown in the Figs.

[0029] A fifth aspect of the invention is the sealing device (123) according to any one of the first to the fourth aspects, wherein the first visco seal rotary portion thread (222) has a first visco seal rotary portion thread angle (222A) from a side of the first visco seal

rotary portion thread (222) to another side of the first visco seal thread on a cross section parallel to and including the rotation axis (1C) of the rotor shaft (1), and wherein the second visco seal rotary portion thread (32242, 32252) has a second visco seal rotary portion thread angle (32242A, 32252A) from a side of the second visco seal rotary portion thread (32242, 32252) to another side of the second visco seal rotary portion thread (32242, 32252) on a cross section parallel to and including the rotation axis (1C) of the rotor shaft (1), preferably wherein the second visco seal rotary portion thread angle (32242A, 32252A) is smaller than the first visco seal rotary portion thread angle (222A) (for prevention of over-heating).

[0030] According to a preferred embodiment of the fifth aspect, wherein the first visco seal rotary portion thread angle (222A) is between 5 and 50 degrees, preferably between 10 and 40 degrees, more preferably between 15 and 35 degrees, still more preferably between 20 and 30 degrees, particularly between 21 and 25 degrees. That is for compromise between efficient sealing and prevention of over-heating. The first visco seal rotary portion thread angle (222A) is 24 degrees in the present example shown in the Figs.

[0031] According to a preferred embodiment of the fifth aspect, wherein second visco seal rotary portion thread angle (32242A, 32252A) is between 0 and 40 degrees, preferably between 5 and 35 degrees, more preferably between 10 and 30 degrees, still more preferably between 15 and 25 degrees, particularly between 16 and 24 degrees. That is for compromise between efficient sealing and prevention of over-heating. The second visco seal rotary portion thread angle (32242A, 32252A) is 21 degrees in the present example shown in the Figs.

[0032] A sixth aspect of the invention is the sealing device (123) according to any one of the first to the fifth aspects, wherein the first visco seal rotary portion thread (222) has a first visco seal rotary portion thread helix angle (222HA) from a direction parallel to the rotation axis (1C) of the rotor shaft (1) to a direction on which the first visco seal rotary portion thread (222) extends, and wherein the second visco seal rotary portion thread (32242, 32252) has a second visco seal rotary portion thread helix angle (32242HA, 32252HA) from a direction parallel to the rotation axis (1C) of the rotor shaft (1) to a direction on which the second visco seal rotary portion thread (32242, 32252) extends, preferably wherein the second visco seal rotary portion thread helix angle (32242HA, 32252HA) is smaller than the first visco seal portion thread helix angle (222HA) (for prevention of over-heating).

[0033] According to preferred embodiment of the sixth aspect, wherein the first visco seal rotary portion thread helix angle (222HA) is between 50 and 90 degrees, preferably between 55 and 85 degrees, more preferably between 60 and 80 degrees, still more preferably between 65 and 75 degrees. That is for compromise between efficient

sealing and prevention of over-heating. The first visco seal rotary portion thread helix angle (222HA) is 70 degrees in the present example shown in the Figs.

[0034] According to preferred embodiment of the sixth aspect, wherein the second visco seal rotary portion thread helix angle (32242HA, 32252HA) is between 30 and 70 degrees, preferably between 35 and 65 degrees, more preferably between 40 and 60 degrees, still more preferably between 45 and 55 degrees. That is for compromise between efficient sealing and prevention of over-heating. The second visco seal rotary portion thread helix angle (32242HA, 32252HA) is 51 degrees in the present example shown in the Figs.

[0035] A seventh aspect of the invention is the sealing device (123) according to any one of the first to the sixth aspects, wherein the first visco seal rotary portion thread (222) has a first visco seal rotary portion thread development of helix (222DH), and wherein the second visco seal rotary portion thread (32242, 32252) has a second visco seal rotary portion thread development of helix (32242DH, 32252DH), preferably wherein the second visco seal rotary portion thread development of helix (32242DH, 32252DH) is shorter than the first visco seal rotary portion thread development of helix (222DH) (for prevention of over-heating), more preferably wherein a ratio of the second visco seal rotary portion thread development of helix (32242DH, 32252DH) to the first visco seal rotary portion thread development of helix (222DH) is between 80.0% and 100.0%, still more preferably between 85.0% and 95.0%. That is for compromise between efficient sealing and prevention of over-heating. The ratio of the second visco seal rotary portion thread development of helix (32242DH, 32252DH) to the first visco seal rotary portion thread development of helix (222DH) is 88.9% in the present example shown in the Figs.

[0036] The first visco seal rotary portion thread development of helix (222DH) is a distance of helix of the first visco seal rotary portion thread (222) during one complete turn (360 degrees) of the rotor shaft (1), and the first visco seal rotary portion thread development of helix (222DH) has the following relation: $222DH=22D\times\pi/\text{Sin}(222HA)$.

[0037] The second visco seal rotary portion thread development of helix (32242DH, 32252DH) is a distance of helix of the second visco seal rotary portion thread (32242, 32252) during one complete turn (360 degrees) of the rotor shaft (1), and the second visco seal rotary portion thread development of helix (32242DH, 32252DH) has the following relation: $32242DH=32D\times\pi/\text{Sin}(32242HA)$, $32252DH=32D\times\pi / \text{Sin}(32252HA)$ in case of that the radially outermost of the second visco seal rotary portion (32) is the radially outermost of the second visco seal rotary portion (32242, 32252) as the present example shown in the Figs.

[0038] According to a preferred embodiment of the seventh aspect, wherein a ratio of the first visco seal rotary portion thread development of helix (222DH) to the rotor shaft

diameter (1D) is between 300.0% and 500.0%, preferably between 330.0% and 470.0%, preferably between 360.0% and 440.0%, more preferably between 390.0% and 410.0%. That is for compromise between efficient sealing and prevention of over-heating. The ratio of the first visco seal rotary portion thread development of helix (222DH) to the rotor shaft diameter (1D) is 398.1% in the present example shown in the Figs.

[0039] According to a preferred embodiment of the seventh aspect, wherein a ratio of the development of helix of the second visco seal rotary portion thread (32242DH, 32252DH) to the rotor shaft diameter (1D) is between 250.0% and 450.0%, preferably between 280.0% and 420.0%, more preferably between 310.0% and 390.0%, still more preferably between 340.0% and 360.0%. That is for compromise between efficient sealing and prevention of over-heating. The ratio of the development of helix of the second visco seal rotary portion thread (32242DH, 32252DH) to the rotor shaft diameter (1D) is 354.0% in the present example in the Figs.

[0040] An eighth aspect of the invention is the sealing device (123) according to any one of the first to the seventh aspects, wherein the first visco seal rotary portion thread (222) has a first visco seal rotary portion thread lead (222L) in a direction parallel to the rotation axis (1C) of the rotor shaft (1), and wherein the second visco seal rotary portion thread (32242, 32252) has a second visco seal rotary portion thread lead (32242L, 32252L) in a direction perpendicular to the rotation axis (1C) of the rotor shaft (1), preferably wherein the second visco seal rotary portion thread lead (32242L, 32252L) is longer than the first visco seal rotary portion thread lead (222L) (for prevention of over-heating), more preferably wherein a ratio of the second visco seal rotary portion thread lead (32242L, 32252L) to the first visco seal rotary portion thread lead (222L) is between 100.0% and 300.0%, still more preferably between 130.0% and 270.0%, particularly 160.0% and 240.0%, more particularly between 190.0% and 210.0%. That is for compromise between efficient sealing and prevention of over-heating. The ratio of the second visco seal rotary portion thread lead (32242L, 32252L) to the first visco seal rotary portion thread lead (222L) is 202.9% in the present example shown in the Figs.

[0041] The first visco seal rotary portion thread lead (222L) is an advance of helix of the first visco seal rotary portion thread (222) in a direction parallel to the rotation axis (1C) of the rotor shaft (1) during one complete turn (360 degrees) of the rotor shaft (1), and the first visco seal rotary portion thread lead (222L) has the following relation: $222L=22D\times\pi/\text{Tan}(222HA)$.

[0042] The second visco seal rotary portion thread lead (32242L, 32252L) is an advance of helix of the second visco seal rotary portion thread (32242, 32252) in a direction parallel to the rotation axis (1C) of the rotor shaft (1) during one complete turn (360

degrees) of the rotor shaft (1), and the second visco seal rotary portion thread lead (32242L, 32252L) has the following relation: $32242L=32D\times\pi/\text{Tan}(32242\text{HA})$, $32252L=32D\times\pi/\text{Tan}(32252\text{HA})$ in case of that the radially outermost of the second visco seal rotary portion (32) is the radially outermost of the second visco seal rotary portion (32242, 32252) as the present example shown in the Figs.

- [0043] According to a preferred embodiment of the eighth aspect, wherein a ratio of the first visco seal rotary portion thread lead (222L) to the rotor shaft diameter (1D) is between 100.0% and 160.0%, preferably between 105.0% and 155.0%, more preferably between 110.0% and 150.0%, still more preferably between 115.0% and 145.0%, particularly between 120.0% and 140.0%. That is for compromise between efficient sealing and prevention of over-heating. The ratio of the first visco seal rotary portion thread lead (222L) to the rotor shaft diameter (1D) is 132.7% in the present example shown in the Figs.
- [0044] According to a preferred embodiment of the eighth aspect, wherein a ratio of the second visco seal rotary portion thread lead (32242L, 32252L) to the rotor shaft diameter (1D) is between 200.0% and 340.0%, preferably between 220.0% and 320.0%, more preferably between 240.0% and 300.0%, still more preferably between 260.0% and 280.0%. That is for compromise between efficient sealing and prevention of over-heating. The ratio of the second visco seal rotary portion thread lead (32242L, 32252L) to the rotor shaft diameter (1D) is 269.4% in the present example shown in the Figs.
- [0045] A ninth aspect of the invention is the sealing device (123) according to any one of the first to the eighth aspects, wherein a number of the second visco seal rotary portion threads (32242, 32252) on a cross section, perpendicular to the rotation axis (1C) of the rotor shaft (1), of the second visco seal rotary portion (32) is larger than a number of the first visco seal rotary portion threads (222) on a cross section, perpendicular to the rotation axis (1C), of the first visco seal rotary portion (22). (for efficient sealing)
- [0046] The number of the first visco seal rotary portion threads (222) on a cross section, perpendicular to the rotation axis (1C), of the first visco seal rotary portion (22) is same as a number of flights (or starts) of the first visco seal rotary portion (22).
- [0047] The number of the second visco seal rotary portion threads (32242, 32252) on a cross section, perpendicular to the rotation axis (1C) of the rotor shaft (1), of the second visco seal rotary portion (32) is same as a number of flights (or starts) of the second visco seal rotary portion (32242, 32252).
- [0048] According to a preferred embodiment of the ninth aspect, wherein the number of the first visco seal rotary portion threads (222) on a cross section, perpendicular to the rotation axis (1C) of the rotor shaft (1), of the first visco seal rotary portion (22) is between 5 and 30, preferably between 6 and 28, more preferably between 7 and 26,

still more preferably between 8 and 24, particularly between 9 and 22, more particularly between 10 and 20, still more particularly between 12 and 18. That is for compromise between efficient sealing and prevention of over-heating. The number of the first visco seal rotary portion threads (222) is 16 in the present example shown in the Figs.

[0049] According to a preferred embodiment of the ninth aspect, wherein the number of the second visco seal rotary portion threads (32242, 32252) on a cross section, perpendicular to the rotation axis (1C) of the rotor shaft (1), of the second visco seal rotary portion (32) is between 30 and 90, preferably between 35 and 85, more preferably between 40 and 80, still more preferably between 45 and 75, particularly between 50 and 70. That is for compromise between efficient sealing and prevention of over-heating. The number of the second visco seal rotary portion threads (32242, 32252) is 60 in the present example shown in the Figs.

[0050] A tenth aspect of the invention is the sealing device (123) according to any one of the first to the ninth aspects, wherein the first visco seal rotary portion thread (222) has a first visco seal rotary portion thread pitch (222P) in a direction parallel to the rotation axis (1C) of the rotor shaft (1), and wherein the second visco seal rotary portion thread (32242, 32252) has a second visco seal rotary portion thread pitch (32242P, 32252P) in a direction perpendicular to the rotation axis (1C) of the rotor shaft (1), preferably wherein the second visco seal rotary portion thread pitch (32242P, 32252P) is longer than the first visco seal rotary portion thread pitch (222P) (for efficient sealing), preferably wherein a ratio of the second visco seal rotary portion thread pitch (32242P, 32252P) to the first visco seal rotary portion thread pitch (222P) is between 10.0% and 100.0%, more between 20.0% and 90.0%, still more preferably between 30.0% and 80.0%, particularly 40.0% and 70.0%, more particularly between 50.0% and 60.0%. That is for compromise between efficient sealing and prevention of over-heating. The ratio of the second visco seal rotary portion thread pitch (32242P, 32252P) to the first visco seal rotary portion thread pitch (222P) is 54.1% in the present example shown in the Figs.

[0051] The first visco seal rotary portion thread pitch (222P) is a distance from a crest of the first visco seal rotary portion thread (222) to the next crest in a direction parallel to the rotation axis (1C) of the rotor shaft (1), and the first visco seal rotary portion thread pitch (222P) has the following relation: $222P = 22D \times \pi / \tan(222HA) / (\text{the number of flights (or starts) of the first visco seal rotary portion (22)})$.

[0052] The second visco seal rotary portion thread pitch (32242P, 32252P) is a distance from a crest of the second visco seal rotary portion threads (32242, 32252) to the next crest in a direction parallel to the rotation axis (1C) of the rotor shaft (1), and the second visco seal rotary portion thread pitch (32242P, 32252P) has the following

relation: $32242P = 32D \times \pi / \tan(32242HA) / (\text{the number of flights (or starts) of the second visco seal rotary portion (32242)})$, $32252P = 32D \times \pi / \tan(32252HA) / (\text{the number of flights (or starts) of the second visco seal rotary portion (32252)})$ in case of that the radially outermost of the second visco seal rotary portion (32) is the radially outermost of the second visco seal rotary portion (32242, 32252) as the present example shown in the Figs.

- [0053] According to a preferred embodiment of the tenth aspect, wherein a ratio of the first visco seal rotary portion thread pitch (222P) to the rotor shaft diameter (1D) is between 2.0% and 15.0%, preferably between 3.0% and 14.0%, more preferably between 4.0% and 13.0%, still more preferably between 5.0% and 12.0%, particularly between 6.0% and 11.0%. That is for compromise between efficient sealing and prevention of over-heating. The ratio of the first visco seal rotary portion thread pitch to the rotor shaft diameter (1D) is 8.3% in the present example shown in the Figs.
- [0054] According to a preferred embodiment of the tenth aspect, wherein a ratio of the second visco seal rotary portion thread pitch (32242P, 32252P) to the rotor shaft diameter (1D) is between 1.0% and 8.0%, preferably between 2.0% and 7.0%, more preferably between 3.0% and 8.0%, still more preferably between 4.0% and 5.0%. That is for compromise between efficient sealing and prevention of over-heating. The ratio of the second visco seal rotary portion thread pitch (32242P, 32252P) to the rotor shaft diameter (1D) is 4.5% in the present example shown in the Figs.
- [0055] An eleventh aspect of the invention is the sealing device (123) according to any one of the first to the tenth aspects, wherein the second visco seal rotary portion (32) has a circumferential surface coated with nitriding, preferably wherein the circumferential surface of the second visco seal rotary portion (32) has a vickers hardness of between 600 and 1200 HV, more preferably between 700 and 1100 HV, still more preferably between 800 and 1000 HV. That can keep improved leak performance for a long time. The circumferential surface of the second visco seal rotary portion (32) is coated with nitriding, and the vickers hardness is 900 HV (in accordance with ISO 6507-1:2005 and ISO 6507-4: 2005) in the present example shown in the Figs.
- [0056] A twelfth aspect of the invention is the sealing device (123) according to any one of the first to the eleventh aspects, wherein a ratio of the first visco seal clearance (2122C) to the rotor shaft diameter (1D) is between 0.1% and 10.0%, preferably between 0.2% and 8.0%, more preferably between 0.3% and 7.0%, still more preferably between 0.4% and 6.0%, particularly between 0.5% and 5.0%. That is for compromise between efficient sealing and prevention of over-heating. The ratio of the first visco seal clearance (2122C) to the rotor shaft diameter (1D) is from 0.9 to 4.2% in the present example shown in the Figs.
- [0057] According to a preferred embodiment of the invention, wherein the second visco seal

(3) is provided with a plural of second visco seal clearances (3132C, 31243214C, 31243224C, 31143224C, 312453224C, 3124532145C, 312453225C, 31153225C, 31253225C, 31253215C) that are distances from the second visco seal stationary portion (31) to the second visco seal rotary portion (32).

[0058] A thirteenth aspect of the invention is the sealing device (123) according to any one of the first to the twelfth aspects, wherein a ratio of the second visco seal clearance (3132C, 31243214C, 31243224C, 31143224C, 312453224C, 3124532145C, 312453225C, 31153225C, 31253225C, 31253215C) to the rotor shaft diameter (1D) is between 0.1% and 15.0%, preferably between 0.2% and 13.0%, more preferably between 0.4% and 11.0%, still more preferably between 0.6% and 10.0%. That is for compromise between efficient sealing and prevention of over-heating. The ratio of the second visco seal clearance (3132C, 31243214C, 31243224C, 31143224C, 312453224C, 3124532145C, 312453225C, 31153225C, 31253225C, 31253215C) to the rotor shaft diameter (1D) is from 0.9% to 9.7% in the present example shown in the Figs.

[0059] A fourteenth aspect of the invention is the sealing device (123) according to any one of the first to the thirteenth aspects, wherein the second visco seal stationary portion (31) comprises at least one second visco seal stationary portion concave (311, 3114, 3115) and at least one second visco seal stationary portion convex part (312, 3124, 31245, 3125) in a direction perpendicular to the rotation axis (1C) of the rotor shaft (1); and wherein the second visco seal rotary portion (32) comprises at least one visco seal rotary portion concave part (3214, 32145, 3215) and at least one visco seal rotary portion convex part (322, 3224, 3225) in a direction to the visco seal stationary portion (31).

[0060] According to a preferred embodiment of the fourteenth aspect, wherein the second visco seal stationary portion (31) comprises a plural of second visco seal stationary concave parts (311, 3114, 3115) and a plural of second visco seal stationary portion convex parts (312, 3124, 31245, 3125) in a direction to the second visco seal rotary portion (32), preferably wherein the second visco seal stationary portion convex parts (312, 3124, 31245, 3125) have a distance (32143215D) from one of the second visco seal stationary portion convex parts (312, 3124, 31245, 3125) to the next in a direction to parallel to the rotation axis (1C) of the rotor shaft (1), and wherein a ratio of the distance (32143215D) to the rotor shaft diameter (1D) is between 0.0% and 20.0%, preferably between 1.0% and 19.0%, more preferably between 2.0% and 18.0%, still more preferably between 3.0% and 17.0%, particularly between 4.0 and 16.0%, more preferably from 5.0 to 15.0%. The ratio of the distance (32143215D) to the rotor shaft diameter (1D) is 10.0% in the present example shown in the Figs.

[0061] According to a preferred embodiment of the fourteenth aspect, wherein the second

visco seal rotary portion (32) comprises a plural of second visco seal rotary portion concave parts (321, 3214, 32145, 3215) and a plural of second visco seal rotary portion convex parts in a direction to the second visco seal stationary portion (31), and the second visco seal rotary portion convex parts made of a plural of second visco seal rotary portions (322, 3224, 3225).

[0062] According to a preferred embodiment of the fourteenth aspect, wherein the second visco seal (3) is provided with a second visco seal stationary portion (31) and second visco seal rotary portion (32) rotating with the rotor shaft (1), and a plural of second visco seal clearances (3132C, 31243214C, 31243224C, 31143224C, 312453224C, 3124532145C, 312453225C, 31153225C, 31253225C, 31253215C) that are distances from the second visco seal stationary portion (31) to the second visco seal rotary portion (32); wherein the second visco seal stationary portion (31) comprises a plural of second visco seal stationary concave parts (311, 3114, 3115) and a plural of second visco seal stationary portion convex parts (312, 3124, 31245, 3125) in a direction to the second visco seal rotary portion (32); wherein the second visco seal stationary concave parts (311, 3114, 3115) comprise: a 1st second visco seal stationary concave part (3114) farther from the discharge side end (5), that is, in the other side end (4) opposite to the discharge side end (5); and a 2nd second visco seal stationary concave part (3115) closer to the discharge side end (5); wherein the second visco seal stationary portion convex parts (312, 3124, 31245, 3125) comprise: a 1st second visco seal stationary portion convex part (3124) farther from the discharge side end (5); a 2nd second visco seal stationary portion convex part (31245) in the next side; and a 3rd second visco seal stationary portion convex part (3125) closer to the discharge side end (5); wherein the second visco seal rotary portion (32) comprises a plural of second visco seal rotary portion concave parts (321, 3214, 32145, 3215) and a plural of second visco seal rotary portion convex parts, made of a plural of second visco seal rotary portions (322, 3224, 3225), in a direction to the second visco seal stationary portion (31); the second visco seal rotary portion concave parts (321, 3214, 32145, 3215) comprise the second visco seal (3): a 1st second visco seal rotary portion concave part (3214) farther from the discharge side end (5) of the rotor shaft (1); a 2nd second visco seal rotary portion concave part (32145) in the next side; and a 3rd second visco seal rotary portion concave part (3215) closer to the discharge side end (5) of the rotor shaft (1); the second visco seal rotary portion convex parts (322, 3224, 3225) comprise the second visco seal (3): a 1st second visco seal rotary portion convex part made of a 1st second visco seal rotary portion (3224) farther from the discharge side end (5); and a 2nd second visco seal rotary portion convex part made of a 2nd second visco seal rotary portion (3225) closer to the discharge side end (5); wherein the second visco seal clearances (3132C, 31243214C, 31243224C, 31143224C, 312453224C,

3124532145C, 312453225C, 31153225C, 31253225C, 31253215C) comprise a 1st second visco seal clearance (31243214C) from the 1st second visco seal stationary portion convex part (3124) to the 1st second visco seal rotary portion concave part (3214) a 2nd second visco seal clearance (31243224C) from the 1st second visco seal stationary portion convex part (3124) to the 1st second visco seal rotary portion convex part (3224); a 3rd second visco seal clearance (31143224C) from the 1st second visco seal stationary concave part (3114) to the 1st second visco seal rotary portion convex part (3224); a 4th second visco seal clearance (312453224C) from the 1st second visco seal stationary portion convex part (3124) to the 1st second visco seal rotary portion convex part (3224); a 5th second visco seal clearance (3124532145C) from the 1st second visco seal stationary portion convex part (3124) to the 2nd second visco seal rotary portion concave part (32145); a 6th second visco seal clearance (312453225C) from the 1st second visco seal stationary portion convex part (3124) to the 2nd second visco seal rotary portion convex part (3225); a 7th second visco seal clearance (31153225C) from the 2nd second visco seal stationary concave part (3115) to the 2nd second visco seal rotary portion convex part (3225); a 8th second visco seal clearance (31253225C) from the 3rd second visco seal stationary portion convex part (3125) to the 2nd second visco seal rotary portion convex part (3225); and a 9th second visco seal clearance (31253215C) from the 3rd second visco seal stationary portion convex part (3125) to the 3rd second visco seal rotary portion concave part (3215).

[0063] A fifteenth aspect of the invention is the sealing device (123) according to any one of the first to the fourteenth aspects, wherein the second visco seal (3) comprises at least one cooling jacket (33), preferably wherein the cooling jacket (33) is arranged in the second visco seal stationary portion (31), more preferably wherein the cooling jacket (33) is provided with at least one cooling line (34), still more preferably wherein the cooling line (34) is connected with a cooling device for circulating a cooling medium through the cooling line (34), particularly wherein the cooling medium is water.

[0064] According to a preferred embodiment of the invention, a kneader is provided with a rotor shaft (1) and a sealing device (123) according to any one of the first to the fifteenth aspects.

[0065] The invention is further illustrated by the following non-limiting examples.

Example

[0066] In order to confirm the effect of the invention, two sealing devices for rotor shafts of kneaders, which are an example according to the invention and a reference, are compared for the leak performance that is each measured leak volume of rubber compositions per day.

[0067] The example is a sealing device (123) for a rotor shaft of a kneader, the sealing device (123) provided with a first visco seal (2) and a second visco seal (3) shown in

the Figs, and the reference is another sealing device for a rotor shaft of a kneader having a rotor shaft diameter and a rotation axis same as that of the example, the sealing device provided without any second visco seal, but with a first visco seal same as that of the example except a first visco seal rotary portion diameter (99% with respect to 22D of the example), a first visco seal rotary portion width (95% with respect to 22W of the example), a first visco seal rotary portion thread height (80% with respect to 222H of the example), a first visco seal thread angle (25 degrees), a first visco seal rotary portion thread helix angle (80 degrees), a first visco seal rotary portion thread development of helix (96% with respect to 222DH of the example), a first visco seal rotary portion thread lead (50% with respect to 222L of the example), a number of flights (or starts) of the first visco seal rotary portion (the number of flights: 10), a first visco seal rotary portion thread pitch (80% with respect to 222P of the example), a first visco seal clearance (1 to 4% with respect to 1D of the example).

[0068] The results (leak performance) are expressed in base 100, that is to say that the value 100 is assigned to the leak volume (Kg) of the reference machine per 1 day, and the relative values of the leak volume (Kg) of the example machine with the sealing device (123) per 1 day is 26. The lower the value is, the better the leak performance is.

[0069] The sealing device (123) for a rotor shaft of a kneader according to the invention allows an unexpectedly improved reduction of leak of mixing material.

Claims

- [Claim 1] A sealing device (123) for a rotor shaft (1) of a kneader; the rotor shaft (1) having a rotor shaft diameter (1D) and a rotation axis (1C);
- the sealing device (123) provided with a first visco seal (2) and a second visco seal (3) arranged closer to a discharge side end (5) of the rotor shaft (1) than the first visco seal (2);
 - the first visco seal (2) provided with a first visco seal stationary portion (21), a first visco seal rotary portion (22) rotating with the rotor shaft (1), and at least one first visco seal clearance (2122C) that is at least one distance from the first visco seal stationary portion (21) to the first visco seal rotary portion (22);
 - the first visco seal rotary portion (22) having at least one first visco seal rotary portion helical groove (221) and at least one first visco seal rotary portion thread (222) formed on a radially outer circumferential surface of the first visco seal rotary portion (22);
 - the first visco seal rotary portion helical groove (221) helically extending around the rotation axis (1C) of the rotor shaft (1);
 - the first visco seal rotary portion thread (222) delimited via the first visco seal rotary portion helical groove (221);
 - the second visco seal (3) provided with a second visco seal stationary portion (31), at least one second visco seal rotary portion (32) rotating with the rotor shaft (1), and at least one second visco seal clearance (3132C, 31243214C, 31243224C, 31143224C, 312453224C, 3124532145C, 312453225C, 31153225C, 31253225C, 31253215C) that is at least one distance from the second visco seal stationary portion (31) to the second visco seal rotary portion (32);
 - the second visco seal rotary portion (32) having at least one second visco seal rotary portion helical groove (32241, 32251) and at least one second visco seal rotary portion thread (32242, 32252) formed on the radially outermost circumferential surface of the second visco seal rotary portion (32);
 - the second visco seal rotary portion helical groove (32241, 32251) helically extending around the rotation axis (1C) of the rotor shaft (1);
- and
- the second visco seal rotary portion thread (32242, 32252) delimited via the second visco seal rotary portion helical groove (32241, 32251).
- [Claim 2] The sealing device (123) according to Claim 1, wherein the first visco

seal rotary portion (22) has a first visco seal rotary portion diameter (22D) that is twice as long as a distance from the radially outermost of the first visco seal rotary portion (22) to the rotation axis (1C) of the rotor shaft (1), wherein the second visco seal rotary portion (32) has a second visco seal rotary portion diameter (32D) that is twice as long as a distance from the radially outermost of the second visco seal rotary portion (32) to the rotation axis (1C) of the rotor shaft (1), and wherein the second visco seal rotary portion diameter (32D) is longer than the first visco seal rotary portion diameter (22D).

[Claim 3]

The sealing device (123) according to Claim 2 or Claim 3, wherein the first visco seal rotary portion (22) has a first visco seal rotary portion width (22W) in a direction parallel to the rotation axis (1C) of the rotor shaft (1), wherein the second visco seal rotary portion (32) has a second visco seal rotary portion width (3224W, 3225W) in a direction parallel to the rotation axis (1C) of the rotor shaft (1), and wherein the second visco seal rotary portion width (3224W, 3225W) is shorter than the first visco seal rotary portion width (22W), preferably wherein a ratio of the second visco seal rotary portion width (3224W, 3225W) to the first visco seal rotary portion width (22W) is between 5.0% and 20.0%, more preferably between 10.0% and 15.0%.

[Claim 4]

The sealing device (123) according to any one of Claims 1 to 3, wherein the first visco seal rotary portion thread (222) has a first visco seal rotary portion thread height (222H) in a direction perpendicular to the rotation axis (1C) of the rotor shaft (1), wherein the second visco seal rotary portion thread (32242, 32252) has a second visco seal rotary portion thread height (32242H, 32252H) in a direction perpendicular to the rotation axis (1C) of the rotor shaft (1), and wherein the second visco seal rotary portion thread height (32242H, 32252H) is shorter than the first visco seal rotary portion thread height (222H), preferably a ratio of the second visco seal rotary portion thread height (32242H, 32252H) to the first visco seal rotary portion thread height (222H) is between 60% and 100%, more preferably between 65% and 95%, still more preferably between 70% and 90%, particularly between 75% and 85%.

[Claim 5]

The sealing device (123) according to any one of Claims 1 to 4, wherein the first visco seal rotary portion thread (222) has a first visco seal rotary portion thread angle (222A) from a side of the first visco seal rotary portion thread (222) to another side of the first visco seal

thread on a cross section parallel to and including the rotation axis (1C) of the rotor shaft (1), wherein the second visco seal rotary portion thread (32242, 32252) has a second visco seal rotary portion thread angle (32242A, 32252A) from a side of the second visco seal rotary portion thread (32242, 32252) to another side of the second visco seal rotary portion thread (32242, 32252) on a cross section parallel to and including the rotation axis (1C) of the rotor shaft (1), and wherein the second visco seal rotary portion thread angle (32242A, 32252A) is smaller than the first visco seal rotary portion thread angle (222A).

[Claim 6]

The sealing device (123) according to any one of Claims 1 to 5, wherein the first visco seal rotary portion thread (222) has a first visco seal rotary portion thread helix angle (222HA) from a direction parallel to the rotation axis (1C) of the rotor shaft (1) to a direction on which the first visco seal rotary portion thread (222) extends, wherein the second visco seal rotary portion thread (32242, 32252) has a second visco seal rotary portion thread helix angle (32242HA, 32252HA) from a direction parallel to the rotation axis (1C) of the rotor shaft (1) to a direction on which the second visco seal rotary portion thread (32242, 32252) extends, and wherein the second visco seal rotary portion thread helix angle (32242HA, 32252HA) is smaller than the first visco seal rotary portion thread helix angle (222HA).

[Claim 7]

The sealing device (123) according to any one of Claims 1 to 6, wherein the first visco seal rotary portion thread (222) has a first visco seal rotary portion thread development of helix (222DH), wherein the second visco seal rotary portion thread (32242, 32252) has a second visco seal rotary portion thread development of helix (32242DH, 32252DH), and wherein the second visco seal rotary portion thread development of helix (32242DH, 32252DH) is shorter than the first visco seal rotary portion thread development of helix (222DH).

[Claim 8]

The sealing device (123) according to any one of Claim 1 to Claim 7, wherein the first visco seal rotary portion thread (222) has a first visco seal rotary portion thread lead (222L) in a direction parallel to the rotation axis (1C) of the rotor shaft (1), wherein the second visco seal rotary portion thread (32242, 32252) has a second visco seal rotary portion thread lead (32242L, 32252L) in a direction perpendicular to the rotation axis (1C) of the rotor shaft (1), and wherein the second visco seal rotary portion thread lead (32242L, 32252L) is longer than the first visco seal rotary portion thread lead (222L).

- [Claim 9] The sealing device (123) according to any one of Claims 1 to 8, wherein a number of the second visco seal rotary portion threads (32242, 32252) on a cross section, perpendicular to the rotation axis (1C) of the rotor shaft (1), of the second visco seal rotary portion (32) is larger than a number of the first visco seal rotary portion threads (222) on a cross section, perpendicular to the rotation axis (1C), of the first visco seal rotary portion (22).
- [Claim 10] The sealing device (123) according to any one of Claims 1 to 9, wherein the first visco seal rotary portion thread (222) has a first visco seal rotary portion thread pitch (222P) in a direction parallel to the rotation axis (1C) of the rotor shaft (1), wherein the second visco seal rotary portion thread (32242, 32252) has a second visco seal rotary portion thread pitch (32242P, 32252P) in a direction perpendicular to the rotation axis (1C) of the rotor shaft (1), and wherein the second visco seal rotary portion thread pitch (32242P, 32252P) is longer than the first visco seal rotary portion thread pitch (222P).
- [Claim 11] The sealing device (123) according to any one of Claims 1 to 10, wherein the second visco seal rotary portion (32) has a circumferential surface coated with nitriding.
- [Claim 12] The sealing device (123) according to any one of Claims 1 to 11, wherein a ratio of the first visco seal clearance (2122C) to the rotor shaft diameter (1D) is between 0.1% and 10.0%.
- [Claim 13] The sealing device (123) according to any one of Claims 1 to 12, wherein a ratio of the second visco seal clearance (3132C, 31243214C, 31243224C, 31143224C, 312453224C, 3124532145C, 312453225C, 31153225C, 31253225C, 31253215C) to the rotor shaft diameter (1D) is between 0.1% and 15.0%, preferably between 0.2% and 13.0%, more preferably between 0.4% and 11.0%, still more preferably between 0.6% and 10.0%.
- [Claim 14] The sealing device (123) according to any one of Claims 1 to 13, wherein the second visco seal stationary portion (31) comprises at least one second visco seal stationary portion concave (311, 3114, 3115) and at least one second visco seal stationary portion convex part (312, 3124, 31245, 3125) in a direction perpendicular to the rotation axis (1C) of the rotor shaft (1); and wherein the second visco seal rotary portion (32) comprises at least one visco seal rotary portion concave part (3214, 32145, 3215) and at least one visco seal rotary portion convex part (322, 3224, 3225) in a direction to the visco seal stationary portion

(31).

[Claim 15]

The sealing device (123) according to any one of Claims 1 to 14, wherein the second visco seal (3) comprises at least one cooling jacket (33), preferably wherein the cooling jacket (33) is arranged in the second visco seal stationary portion (31), more preferably wherein the cooling jacket (33) is provided with at least one cooling line (34), still more preferably wherein the cooling line (34) is connected with a cooling device for circulating a cooling medium through the cooling line (34), particularly wherein the cooling medium is water.

[Fig. 1]

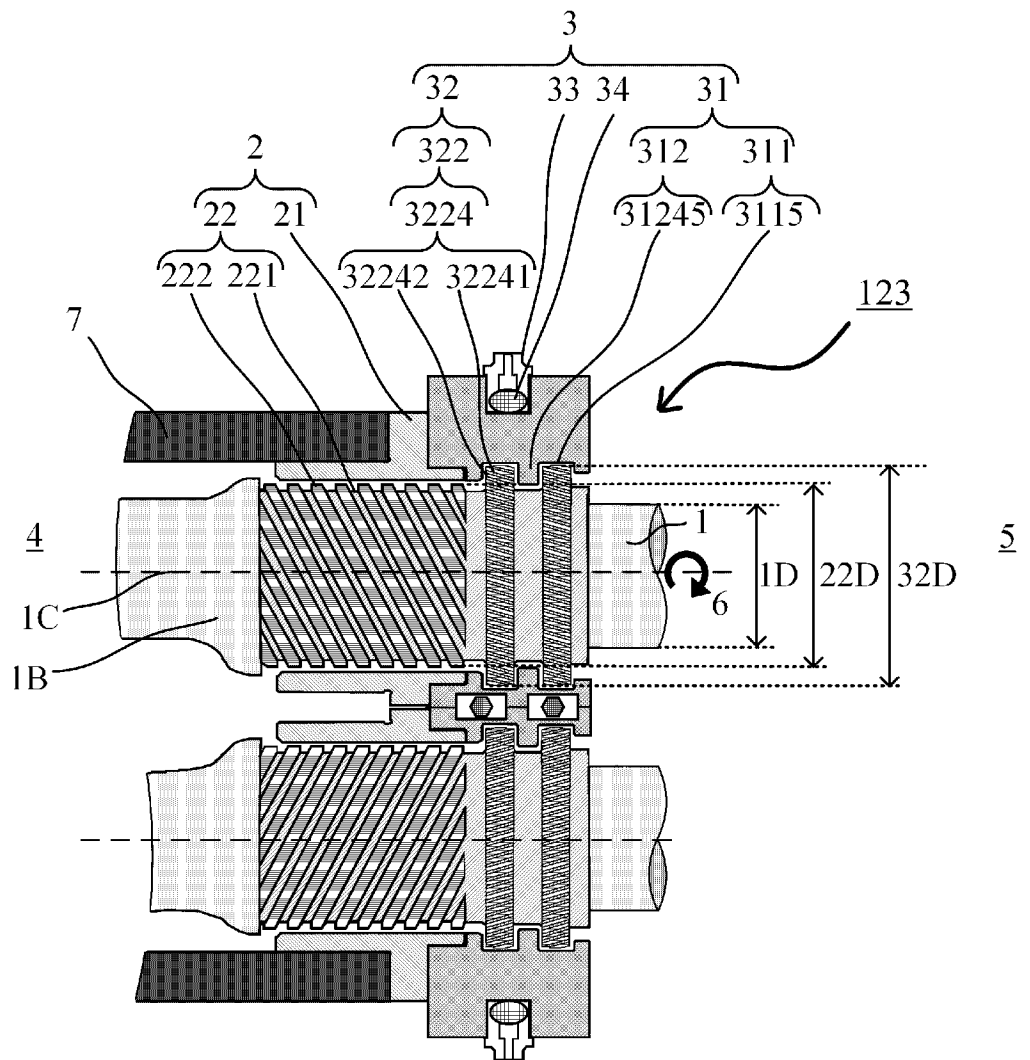

[Fig. 2]

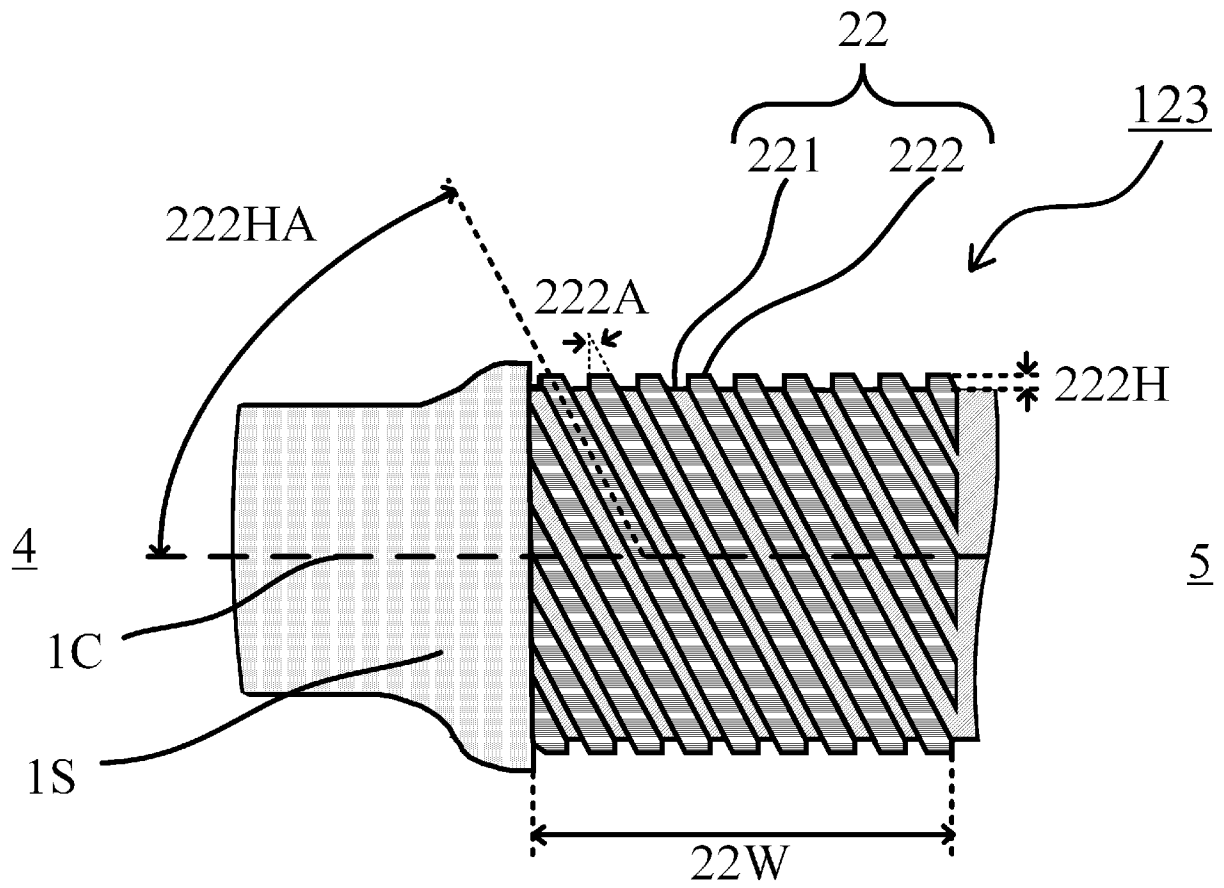

[Fig. 3]

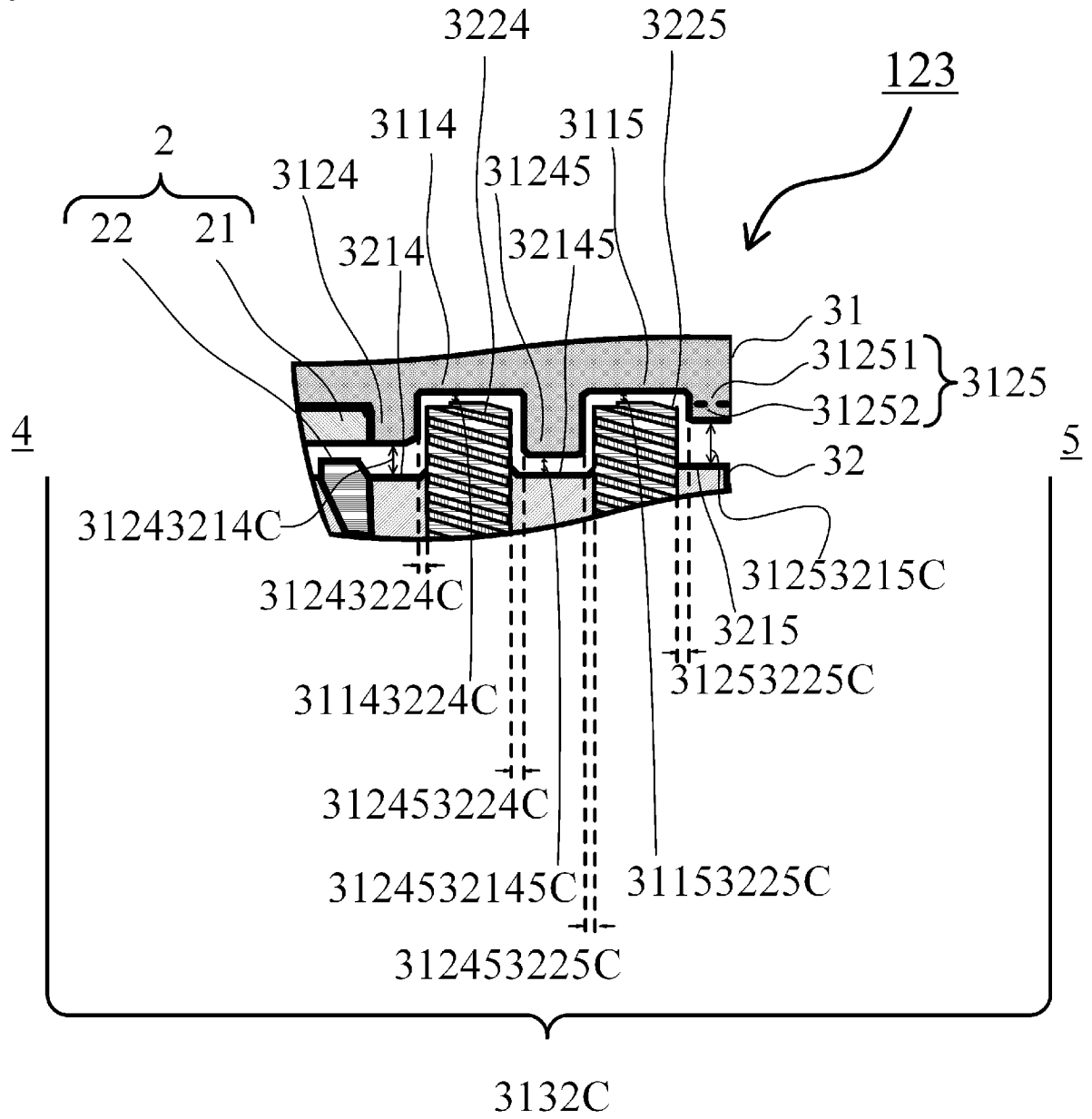

[Fig. 4]

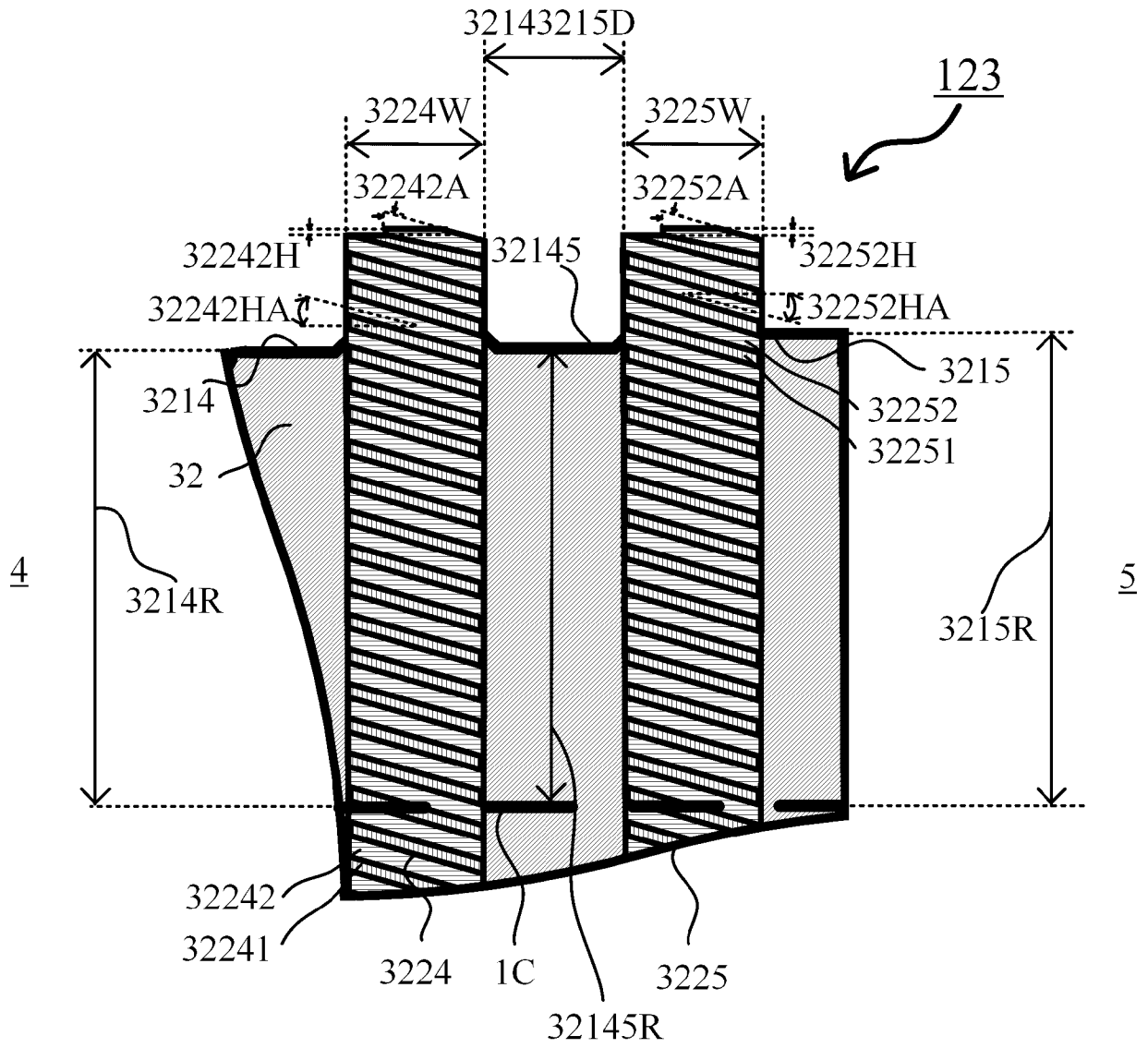

INTERNATIONAL SEARCH REPORT

International application No
PCT/JP2021/024462

A. CLASSIFICATION OF SUBJECT MATTER
INV. B29C48/25 B29B7/22 B29B7/48 B29B7/58
ADD.

According to International Patent Classification (IPC) or to both national classification and IPC

B. FIELDS SEARCHED
 Minimum documentation searched (classification system followed by classification symbols)
B29C B29B F16J

Documentation searched other than minimum documentation to the extent that such documents are included in the fields searched

Electronic data base consulted during the international search (name of data base and, where practicable, search terms used)
EPO-Internal, WPI Data

C. DOCUMENTS CONSIDERED TO BE RELEVANT

Category*	Citation of document, with indication, where appropriate, of the relevant passages	Relevant to claim No.
X	JP 5 167201 B2 (KOBE STEEL LTD) 21 March 2013 (2013-03-21) figures 6, 6(b)	1, 9, 11-15 2-8, 10
A	-----	
A	JP 2004 293639 A (KOBE STEEL LTD) 21 October 2004 (2004-10-21) paragraphs [0004] - [0006]; figure 2	1-15
A	JP H08 128535 A (KOBE STEEL LTD) 21 May 1996 (1996-05-21) paragraph [0014]; claims 1-4; figures 1-6	1-15
A	JP H11 170251 A (KOBE STEEL LTD) 29 June 1999 (1999-06-29) paragraph [0015]; claims 1-5; figures 1, 8	1-15
	----- -/--	

Further documents are listed in the continuation of Box C. See patent family annex.

* Special categories of cited documents :

<p>"A" document defining the general state of the art which is not considered to be of particular relevance</p> <p>"E" earlier application or patent but published on or after the international filing date</p> <p>"L" document which may throw doubts on priority claim(s) or which is cited to establish the publication date of another citation or other special reason (as specified)</p> <p>"O" document referring to an oral disclosure, use, exhibition or other means</p> <p>"P" document published prior to the international filing date but later than the priority date claimed</p>	<p>"T" later document published after the international filing date or priority date and not in conflict with the application but cited to understand the principle or theory underlying the invention</p> <p>"X" document of particular relevance; the claimed invention cannot be considered novel or cannot be considered to involve an inventive step when the document is taken alone</p> <p>"Y" document of particular relevance; the claimed invention cannot be considered to involve an inventive step when the document is combined with one or more other such documents, such combination being obvious to a person skilled in the art</p> <p>"&" document member of the same patent family</p>
---	---

Date of the actual completion of the international search 3 March 2022	Date of mailing of the international search report 14/03/2022
--	---

Name and mailing address of the ISA/ European Patent Office, P.B. 5818 Patentlaan 2 NL - 2280 HV Rijswijk Tel. (+31-70) 340-2040, Fax: (+31-70) 340-3016	Authorized officer Ferrer Santos, A
--	---

INTERNATIONAL SEARCH REPORT

International application No

PCT/JP2021/024462

C(Continuation). DOCUMENTS CONSIDERED TO BE RELEVANT		
Category*	Citation of document, with indication, where appropriate, of the relevant passages	Relevant to claim No.
A	JP 2014 185627 A (SEKISUI PLASTICS TENRI CO LTD; SEKISUI PLASTICS) 2 October 2014 (2014-10-02) paragraphs [0003], [0035] -----	1-15
A	JP H06 87119 A (KOBE STEEL LTD) 29 March 1994 (1994-03-29) paragraphs [0002], [0012], [0018], [0010] - [0019]; figures 1-4 -----	1-15
A	JP H11 285200 A (MATSUSHITA ELECTRIC IND CO LTD) 15 October 1999 (1999-10-15) paragraphs [0046], [0086]; figures 1,2,7-9 -----	1-15
A	JP 2017 020412 A (EBARA CORP) 26 January 2017 (2017-01-26) paragraph [0004]; claims 1-5 -----	1-15

INTERNATIONAL SEARCH REPORT

Information on patent family members

International application No

PCT/JP2021/024462

Patent document cited in search report	Publication date	Patent family member(s)	Publication date
JP 5167201 B2	21-03-2013	JP 5167201 B2 JP 2011001937 A	21-03-2013 06-01-2011
JP 2004293639 A	21-10-2004	JP 4009547 B2 JP 2004293639 A	14-11-2007 21-10-2004
JP H08128535 A	21-05-1996	JP 3444990 B2 JP H08128535 A	08-09-2003 21-05-1996
JP H11170251 A	29-06-1999	JP 3550490 B2 JP H11170251 A	04-08-2004 29-06-1999
JP 2014185627 A	02-10-2014	NONE	
JP H0687119 A	29-03-1994	JP 3155367 B2 JP H0687119 A	09-04-2001 29-03-1994
JP H11285200 A	15-10-1999	NONE	
JP 2017020412 A	26-01-2017	NONE	