

(19) World Intellectual Property Organization
International Bureau



(43) International Publication Date
31 March 2005 (31.03.2005)

PCT

(10) International Publication Number
WO 2005/029472 A3

(51) International Patent Classification⁷: G11B 7/0045, 7/007

(21) International Application Number: PCT/IB2004/051727

(22) International Filing Date: 9 September 2004 (09.09.2004)

(25) Filing Language: English

(26) Publication Language: English

(30) Priority Data: 03103470.5 19 September 2003 (19.09.2003) EP

(71) Applicant (for all designated States except US): KONINKLIJKE PHILIPS ELECTRONICS N.V. [NL/NL]; Groenewoudseweg 1, NL-5621 BA Eindhoven (NL).

(72) Inventors; and

(75) Inventors/Applicants (for US only): VAN ROMPAEY, Bart [BE/BE]; c/o Prof. Holstlaan 6, NL-5656 AA Eindhoven (NL). KUIJPER, Maarten [NL/NL]; c/o Prof. Holstlaan 6, NL-5656 AA Eindhoven (NL).

(74) Agent: UITTENBOGAARD, Frank; Prof. Holstlaan 6, NL-5656 AA Eindhoven (NL).

(81) Designated States (unless otherwise indicated, for every kind of national protection available): AE, AG, AL, AM,

AT, AU, AZ, BA, BB, BG, BR, BW, BY, BZ, CA, CH, CN, CO, CR, CU, CZ, DE, DK, DM, DZ, EC, EE, EG, ES, FI, GB, GD, GE, GH, GM, HR, HU, ID, IL, IN, IS, JP, KE, KG, KP, KR, KZ, LC, LK, LR, LS, LT, LU, LV, MA, MD, MG, MK, MN, MW, MX, MZ, NA, NI, NO, NZ, OM, PG, PH, PL, PT, RO, RU, SC, SD, SE, SG, SK, SL, SY, TJ, TM, TN, TR, TT, TZ, UA, UG, US, UZ, VC, VN, YU, ZA, ZM, ZW.

(84) Designated States (unless otherwise indicated, for every kind of regional protection available): ARIPO (BW, GH, GM, KE, LS, MW, MZ, NA, SD, SL, SZ, TZ, UG, ZM, ZW), Eurasian (AM, AZ, BY, KG, KZ, MD, RU, TJ, TM), European (AT, BE, BG, CH, CY, CZ, DE, DK, EE, ES, FI, FR, GB, GR, HU, IE, IT, LU, MC, NL, PL, PT, RO, SE, SI, SK, TR), OAPI (BF, BJ, CF, CG, CI, CM, GA, GN, GQ, GW, ML, MR, NE, SN, TD, TG).

Declaration under Rule 4.17:

— as to applicant's entitlement to apply for and be granted a patent (Rule 4.17(ii)) for the following designations AE, AG, AL, AM, AT, AU, AZ, BA, BB, BG, BR, BW, BY, BZ, CA, CH, CN, CO, CR, CU, CZ, DE, DK, DM, DZ, EC, EE, EG, ES, FI, GB, GD, GE, GH, GM, HR, HU, ID, IL, IN, IS, JP, KE, KG, KP, KR, KZ, LC, LK, LR, LS, LT, LU, LV, MA, MD, MG, MK, MN, MW, MX, MZ, NA, NI, NO, NZ, OM, PG, PH, PL, PT, RO, RU, SC, SD, SE, SG, SK, SL, SY, TJ, TM, TN, TR, TT, TZ, UA, UG, UZ, VC, VN, YU, ZA, ZM,

[Continued on next page]

(54) Title: OPTICAL RECORD CARRIER RECORDING METHOD, OPTICAL RECORD CARRIER AND APPARATUS FOR WRITING INFORMATION

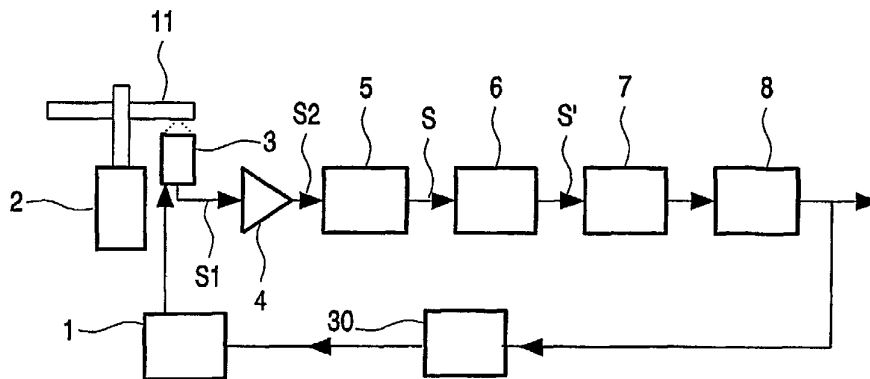

(57) Abstract: Described is an optical record carrier recording method, optical record carrier (11) and an apparatus for writing information to an optical record carrier (11). The optical record carrier recording method forms pits and lands by controlling a radiation source to direct a radiation beam onto a recording surface of an optical record carrier (11), the method comprises the steps of: reading a write strategy from the optical record carrier (11) which comprises at least two write strategies, and forming the pits and lands by controlling the radiation source with the read write strategy, wherein the method further comprises a step of determining which of the at least two write strategies is the most optimal one by reading an indication present on the optical record carrier (11), and wherein the method uses the most optimal write strategy to form the pits and the lands. If an apparatus for writing information to an optical record carrier (11) is capable of applying two or more write strategies stored on the optical record carrier, then the apparatus reads the indication and applies the write strategy which is the most optimal one.

WO 2005/029472 A3



ZW, ARIPO patent (BW, GH, GM, KE, LS, MW, MZ, NA, SD, SL, SZ, TZ, UG, ZM, ZW), Eurasian patent (AM, AZ, BY, KG, KZ, MD, RU, TJ, TM), European patent (AT, BE, BG, CH, CY, CZ, DE, DK, EE, ES, FI, FR, GB, GR, HU, IE, IT, LU, MC, NL, PL, PT, RO, SE, SI, SK, TR), OAPI patent (BF, BJ, CF, CG, CI, CM, GA, GN, GQ, GW, ML, MR, NE, SN, TD, TG)

— before the expiration of the time limit for amending the claims and to be republished in the event of receipt of amendments

(88) Date of publication of the international search report:
11 August 2005

Published:

— with international search report

For two-letter codes and other abbreviations, refer to the "Guidance Notes on Codes and Abbreviations" appearing at the beginning of each regular issue of the PCT Gazette.

Optical record carrier recording method, optical record carrier and apparatus for writing information

5 The invention pertains to an optical record carrier method for forming pits and lands by controlling a radiation source to direct a radiation beam onto a recording surface of an optical record carrier.

The invention further pertains to an optical record carrier.

The invention also pertains to an apparatus for writing information to an optical record carrier.

10 Optical media store data in digital form, and include all the various CD and DVD and Blu-ray Disc optical disk technologies. The data stored on this media can consist of video, text, audio, computer data, or any other form of digital information. This data is written to and read from an optical disk using a laser.

15 There are various manufacturers of optical disks. Therefore many different formats and disk types are commercially available. Even within a standardized disc format, such as for example CD-R, CD-R/W, DVD-R, DVD-R/W, BD+R, BD+R/W, each type of optical disk may possess different material parameters. Because of this, each type may behave differently when exposed to a write pulse from a laser. If uncompensated, these differences in behavior result in variations in write performance, such as for example in the jitter and the asymmetry of the written marks. Therefore, for optimum write performance each type of optical disk may require a different write strategy to compensate for its material parameters and other characteristics.

20 In this application a mark is understood to be any type of optically detectable area on an optical disk. It includes a pit formed by locally heating the area on the optical disk and amorphous areas in a crystalline layer in the optical disk. A write strategy is understood to be any sequence of laser pulses, generated by the laser, causing a mark to be formed on the optical disk when irradiated by the laser pulses.

25 In one approach an optimal writing strategy is developed for each optical disk by conducting a test writing before attempting to write user information to the disk. The test writing is, in general, made on an inner portion of a lead-in area of the optical disk while incrementally adjusting the write power. Next, the recorded information is read from the test area. The write power at which the desired quality (for example a lowest error rate, an optimum modulation factor, or a

35

lowest jitter factor) and asymmetry of the test writing is obtained is selected as the optimum write power, which is thereafter used for actual recording of user information. However, this approach is disadvantageous in that the results of the test writing are not retained by the disk drive. Therefore, the test writing must be repeated, even on optical disks of the same type, which can be burdensome. Furthermore, each parameter of the write strategy must be developed for each disk, thereby requiring a significant analysis of the characteristics of the test writing.

Another approach requires each optical disk type to be "registered" by an optical disk drive when that drive is manufactured. During the development of an optical disk drive, its manufacturer investigates and develops an optimal write strategy for each type of optical disk of which the drive manufacturer is aware. The manufacturer then compiles data representing a list of compatible optical disk types along with the corresponding optimal write strategy for each optical disk type. This data is often stored in the optical disk drive in a control information memory such as for example an EEPROM, and may contain such recording parameters as the optimum write power, the time modulation, the linear velocity, and the recording speed. A drive then can recognize a particular optical disk type by scanning the lead-in portion of the disk. The characteristics of the lead-in portion of each optical disk type varies by disk manufacturer, thus identifying the manufacturer of the disk.

In WO 03/03153 a method and recording device are disclosed which select and learn an optimal write strategy by testing the performance of different known write strategies, selecting the best write strategy for the particular optical disk type, and storing that information for use when the same optical disk type is subsequently encountered. Information about the best write strategy will be stored in the recording device for use when the same optical disk type is subsequently encountered. However, the information about the best write strategy for use with a specific disk is written to the disk itself. When the disk is subsequently encountered, this information is read from the disk and used by the recording device for selecting the best write strategy.

An apparatus for writing information to an optical record carrier is capable of applying certain write strategies. However, if for a certain type of optical record carrier a new write strategy is developed, it is possible that the apparatus is incapable of applying the new write strategy. Therefore, it is common to write more than one write strategy onto the optical record carrier. The apparatus can then select a write strategy which he can apply. However, if at least two write strategies are written onto the optical record carrier, and the apparatus is capable of applying

both, the apparatus does not know which one is the most optimal for that optical record carrier. In the case that even more write strategies are stored onto the optical record carrier the choice becomes even bigger and more likely that not the most optimal write strategy is chosen. The most optimal write strategy also depends on the writing speed with which data is written on the optical record carrier.

Throughout this specification the word "comprise", or variations such as "comprises" or "comprising", will be understood to imply the inclusion of a stated element, integer or step, or group of elements, integers or steps, but not the exclusion of any other element, integer or step, or group of elements, integers or steps.

Any discussion of documents, acts, materials, devices, articles or the like which has been included in the present specification is solely for the purpose of providing a context for the present invention. It is not to be taken as an admission that any or all of these matters form part of the prior art base or were common general knowledge in the field relevant to the present invention as it existed before the priority date of each claim of this application.

It is an advantage of at least one embodiment of the present invention to provide an optical record carrier recording method which is capable of determining the most optimal write strategy.

It is also an advantage of at least one embodiment of the present invention to provide an optical record carrier to be used in such a method.

It is a further an advantage of at least one embodiment of the present invention to provide an apparatus for writing information to an optical record carrier which is capable of determining the most optimal write strategy.

According to a first aspect the invention provides an optical record carrier method for forming pits and lands by controlling a radiation source to direct a radiation beam onto a recording surface of an optical record carrier, the method comprising the steps of:

reading a write strategy from the optical record carrier which comprises at least two write strategies, and

forming the pits and lands by controlling the radiation source with the read write strategy,

wherein the method further comprises a step of determining which of the at least two write strategies is the most optimal one by reading an indicator present on the optical record carrier, and wherein the method uses the most optimal

write strategy to form the pits and the lands

wherein the indicator further indicates in which order the write strategies are preferred for the optical record carrier on which the indicator is stored, that the method is capable of determining which of the write strategies can be applied by the method and that the method determines from the applicable write strategies which is the most optimal one, the method thereby using the order of preference indicated by the indicator.

According to a second aspect the invention provides an optical record carrier comprises at least two write strategies, wherein the optical record carrier further comprises an indicator which of the at least two write strategies is the most optimal one

wherein the indicator further indicates in which order the write strategies are preferred for the optical record carrier on which the indicator is stored.

According to a third aspect the invention provides an apparatus for writing information to an optical record carrier comprising:

a write head for generating a radiation beam and directing the beam onto a recording surface of the optical record carrier,

reading means for reading a write strategy from the optical record carrier which comprises at least two write strategies and for reading an indicator which of the at least two write strategies is the most optimal one,

a write head controller for controlling the write head with the read write strategy for forming pits and lands,

a processor for controlling the apparatus, the processor being capable of determining which of the at least two write strategies is the most optimal one from the read indicator,

wherein the write head controller is capable of using the most optimal write strategy to form the pits and the lands,

wherein the indicator further indicates in which order the write strategies are preferred for the optical record carrier on which the indicator is stored, that the processor is capable of determining which of the write strategies can be applied by the write head controller and that the processor determines from the applicable write strategies which is the most optimal one, the processor thereby using the order of preference indicated by the indicator.

If an apparatus for writing information to an optical record carrier is capable of applying two or more write strategies stored on the optical record carrier,

then the apparatus reads the indication and applies the write strategy which is the most optimal one.

5 If there are write strategies present on the optical record carrier which can not be applied by the apparatus then the apparatus has to determine which of the write strategies it can apply is the most optimal one. Therefore in an embodiment of the present invention the indicator further indicates in which order the write strategies are preferred for the optical record carrier on which the indicator is stored and wherein the method is capable of determining which of the write strategies can be applied by the method and wherein the method determines from 10 the applicable write strategies which is the most optimal one, the method thereby using the order of preference indicated by the indicator. For instance, if there are three write strategies present an the most optimal one can not be applied by the method, than the apparatus picks the write strategy is the second optimal one.

15 The indication can be in the form of additional information stored on the optical record carrier, such as byte after each write strategy which value indicates how optimal that write strategy is. How optimal the write strategies are can also be indicated by the sequential order in which the write strategies are stored on the optical record carrier. For instance, the write strategies can be stored in a disc information table present in a zone of the optical record carrier called the Control 20 Data Zone. The first write strategy in the disc information table is the most optimal one. The second write strategy in the disc information table is the second most optimal one, and so on.

25 In a further embodiment of the present invention the method reads an additional byte contained in the write strategies which additional byte describes a write velocity for which the write strategy can be applied and wherein the method reads the additional information by reading an additional bit or byte contained in the write strategies which indicates if the write strategy is the most optimal one for that write velocity. The apparatus performing this method and which is capable of writing at different writing velocities, can select the most optimal write strategy 30 dependent on the writing velocity.

These and other aspects of the apparatus, information carrier and method according to the invention will be apparent from and elucidated by means of the drawings, in which:

5 Fig. 1 shows an apparatus for writing information according to the invention,
Fig. 2a shows an information carrier (top view),
Fig. 2b shows an information carrier (cross section),
Fig. 3 shows an example of the information zone of an information carrier,
Fig. 4 shows a table of an example of physical format information,
10 Fig. 5 shows a flow chart of a optical record carrier recording method in accordance with the invention.

The apparatus for writing information shown in Fig. 1 comprises a write head 3 for reading the information from an information carrier 11. A displacement means 2 is able
15 to cause a relative displacement between the information carrier 11 and the write head 3. In operation, an output signal S_1 of the read head 3 is fed to an amplifier 4. The amplifier 4 amplifies the output signal S_1 to a desired level and supplies an amplified signal S_2 to an analog to digital A/D converter 5. The A/D converter 5 converts the amplified signal S_2 to a sampled read signal S, using a sampling period of T seconds. The sampled read signal S is
20 fed to the waveform equalizer 6. The waveform equalizer 6 obtains a corrected signal S' by performing a waveform equalization to the read signal S. The output of the waveform equalizer 6 is fed to bit-detection means 7. The output of the bit-detection means 7 is fed to channel decoding means 8. The write head is controlled by the write head controller 1. The processor 30 controls the apparatus. The processor 30 controls the write head 3 to read out
25 the indicator and then determines the most optimal write strategy indicated by the indicator. If the most optimal write strategy can be applied by the apparatus, then the write head controller 1 is provided with the optimal write strategy. Writing information is subsequently performed by using the most optimal write strategy.

30 Fig. 2a shows a disc-shaped information carrier 11 having a track 9 and a central hole 10. The track 9, being the position of the series of (to be) recorded marks representing information, is arranged in accordance with a spiral pattern of turns constituting substantially parallel tracks on an information layer. The information carrier may be optically readable, called an optical disc, and has an information layer of a recordable type. Examples of a recordable disc are the CD-R and CD-RW, and writable versions of DVD, such as

DVD+RW. Further details about the DVD disc can be found in reference: *ECMA-267: 120 mm DVD – Read-Only Disc - (1997)*. The information is represented on the information layer by recording optically detectable marks along the track, e.g. crystalline or amorphous marks in phase change material. The track 9 on the recordable type of information carrier is

5 indicated by a pre-embossed track structure provided during manufacture of the blank information carrier. The track structure is constituted, for example, by a pregroove 14 which enables a read/write head to follow the track during scanning. The track structure comprises position information, e.g. addresses, for indication the location of units of information, usually called information blocks. The position information includes specific synchronizing

10 marks for locating the start of such information blocks. The position information is encoded in frames of modulated wobbles as described below.

Fig. 2b shows a part of a cross-section taken along the line b-b of the information carrier 11 of the recordable type, in which a transparent substrate 15 is provided with a recording layer 16 and a protective layer 17. The protective layer 17 may comprise a

15 further substrate layer, for example as in DVD where the recording layer is at a 0.6 mm substrate and a further substrate of 0.6 mm is bonded to the back side thereof. The pregroove 14 may be implemented as an indentation or an elevation of the substrate 15 material, or as a material property deviating from its surroundings.

The information carrier 11 is intended for carrying information represented by

20 modulated signals comprising frames. A frame is a predefined amount of data preceded by a synchronizing signal. Usually such frames also comprise error correction codes, e.g. parity words. A number of such frames constitute an information block, the information block comprising further error correction words. The information block is the smallest recordable unit from which information can be reliably retrieved. An example of such a recording

25 system is known from the DVD system, in which the frames carry 172 data words and 10 parity words, and 208 frames constitute an ECC block.

Fig. 3 shows an example of the information zone 20 of an information carrier 11. The information zone 20 contains all the information on the information carrier relevant for data interchange. The Inner Drive Area 21 and Outer Drive Area 25 are meant for disc

30 testing. The Lead-in Zone 22 contains control information. The Lead-out Zone 24 allows for a smooth lead-out and also contains control information. The Data zones 23 are intended for recording of user data. The Lead-in Zone contains a Control Data Zone.

Fig. 4 shows a table of an example of physical format information contained in the Control Data Zone. The Physical format information is encoded in ADIP as described

above. This information shall comprise the 256 bytes shown in Fig. 4. It contains disc information and values used for the Optimum Power Control (OPC) algorithm to determine optimum laser power levels for writing. The information is copied into a recordable zone called the Control Data during initialization of the disc. The data contents are for example:

5 **Byte 0 - Disc Category and Version Number**

Bits b7 to b4 shall specify the Disc Category,
they shall be set to 1010, indicating a DVD+R disc.

Bits b3 to b0 shall specify the Version Number,
they shall be set to 0000 indicating the version

10 **Byte 1 - Disc size and maximum transfer rate**

Bits b7 to b4 shall specify the disc size,
they shall be set to 0000, indicating a 120 mm disc

Bits b3 to b0 shall specify the maximum read transfer rate,
they shall be set to 1111 indicating no maximum read transfer rate is
15 specified

Byte 2 - Disc structure

Bit b7 to b4 shall be set to 0000

Bits b3 to b0 shall specify the type of the recording layer(s):
they shall be set to 0010, indicating a write-once recording layer.

20 **Byte 3 - Recording density**

Bits b7 to b4 shall specify the average Channel bit length in the Information Zone,
they shall be set to 0000, indicating 0,133 μm

Bits b3 to b0 shall specify the average track pitch,
they shall be set to 0000, indicating an average track pitch of 0,74 μm

25 **Bytes 4 to 15 - Data Zone allocation**

Byte 4 shall be set to (00).

Bytes 5 to 7 shall be set to (030000) to specify PSN 196.608 of the first Physical Sector of
the Data Zone

Byte 8 shall be set to (00).

30 Bytes 9 to 11 shall be set to (26053F) to specify PSN 2.491.711 as the last possible Physical
Sector of the Data Zone.

Bytes 12 to 15 shall be set to (00)

Byte 16 – (00) shall be set to (00).

Byte 17 - Reserved. This byte is reserved and shall be set to (00).

Byte 18 – Extended information indicators

Bits b7 to b6 are reserved and shall be set to 00

Bits b5 to b0 each of these bits shall indicate the presence of an Extended Information block. Bit b_i shall be set to 1 if Extended Information block i , consisting of bytes $(64 + i \times 32)$ to $(95 + i \times 32)$, is in use. Else bit b_i shall be set to 0.

Bytes 19 to 26 - Disc Manufacturer ID.

These 8 bytes shall identify the manufacturer of the disc. Trailing bytes not used shall be set to (00).

10 Bytes 27 to 29 – Media type ID.

Disc manufacturers can have different types of media, which shall be specified by these 3 bytes. The specific type of disc is denoted in this field.

Byte 30 – Product revision number.

This byte shall identify the product revision number in binary notation. All discs with the same Disc Manufacturer ID and the same Product ID, regardless of Product revision numbers, must have the same recording properties (only minor differences are allowed: Product revision numbers shall be irrelevant for recorders). If not used this byte shall be set to (00)

Byte 31 number of Physical format information bytes in use.

This byte forms one 8-bit binary number indicating the number of bytes actually in use for Physical format information. It shall be set to (36) indicating that only the first 54 bytes of the Physical format information are used.

Byte 32 – Reference recording velocity.

This byte indicates the lowest possible recording velocity of the disc, which is also referred to as the Reference velocity, as a number n such that

$$n = 10 \times v_{\text{ref}} \text{ (n rounded off to an integral value)}$$

It shall be set to (23) indicating a Reference writing speed of 3,49 m/s.

Byte 33 – Maximum recording velocity.

This byte indicates the highest possible recording velocity of the disc, as a number n such that

$$n = 10 \times v_{\text{ref}} \text{ (n rounded off to an integral value)}$$

It shall be set to (54) indicating a maximum writing speed of 8,44 m/s.

Byte 34 - Wavelength λ IND.

This byte shall specify the wavelength in nanometers of the laser with which the optimum write parameters in the following bytes have been determined, as a number n such that

$$n = \text{Wavelength} - 600$$

5 **Byte 35** **Reserved**

Byte 36 **Maximum read power, P_r at reference velocity.**

This byte shall specify the maximum read power P_r in milliwatts at the reference velocity as a number n such that

$$n = 20 \times (P_r - 0,7)$$

10 **Byte 37 - PIND at reference velocity.**

PIND is the starting value for the determination of P_{po} used in the OPC algorithm. This byte shall specify the indicative value PIND of P_{po} in milliwatts at the reference velocity as a number n such that

$$n = 20 \times (P_{IND} - 5)$$

15 **Byte 38 - β_{target} at reference velocity.**

This byte shall specify the target value for β , β_{target} at the reference velocity used in the OPC algorithm as a number n such that

$$n = 10 \times \beta_{target}$$

Byte 39 - Maximum read power, P_r at maximum velocity.

20 This byte shall specify the maximum read power P_r in milliwatts at the maximum velocity as a number n such that

$$n = 20 \times (P_r - 0,7)$$

Byte 40 - P_{IND} at maximum velocity.

25 P_{IND} is the starting value for the determination of P_{po} used in the OPC algorithm. This byte shall specify the indicative value PIND of P_{po} in milliwatts at the maximum velocity as a number n such that

$$n = 20 \times (PIND - 5)$$

Byte 41 - β_{target} at maximum velocity.

30 This byte shall specify the target value for β , β_{target} at the maximum velocity used in the OPC algorithm as a number n such that

$$n = 10 \times \beta_{target}$$

Byte 42 - $T_{top} (\geq 4)$ first pulse duration for current mark ≥ 4 at reference velocity.

This byte shall specify the duration of the first pulse of the multi pulse train when the current mark is a 4T or greater mark for recording at reference velocity. The value is expressed in fractions of the channel bit clock period as a number n such that

$$5 \quad n = 16 \times \frac{T_{top}}{T_w} \quad \text{and} \quad 4 \leq n \leq 40$$

Byte 43 - Ttop (=3) first pulse duration for current mark =3 at reference velocity.

This byte shall specify the duration of the first pulse of the multi pulse train when the current mark is a 3T mark for recording at reference velocity. The value is expressed in fractions of the channel bit clock period as a number n such that

$$10 \quad n = 16 \times \frac{T_{top}}{T_w} \quad \text{and} \quad 4 \leq n \leq 40$$

Byte 44 - Tmp multi pulse duration at reference velocity.

This byte shall specify the duration of the 2nd pulse through the 2nd to last pulse of the multi pulse train for recording at reference velocity. The value is expressed in fractions of the channel bit clock period as a number n such that

$$15 \quad n = 16 \times \frac{T_{mp}}{T_w} \quad \text{and} \quad 4 \leq n \leq 16$$

Byte 45 - Tlp last pulse duration at reference velocity.

This byte shall specify the duration of the last pulse of the multi pulse train for recording at reference velocity. The value is expressed in fractions of the channel bit clock period as a number n such that

$$20 \quad n = 16 \times \frac{T_{lp}}{T_w} \quad \text{and} \quad 4 \leq n \leq 24$$

Byte 46 - dTtop first pulse lead time at reference velocity.

This byte shall specify the lead time of the first pulse of the multi pulse train relative to the trailing edge of the second channel bit of the data pulse for recording at reference velocity. The value is expressed in fractions of the channel bit clock period as a number n such that

$$25 \quad n = 16 \times \frac{dT_{top}}{T_w} \quad \text{and} \quad 0 \leq n \leq 24$$

Byte 47 - dTle 1st pulse leading edge correction for previous space =3 at reference velocity.

Bit 7 to bit 4 of this byte shall specify the leading edge correction for the 1st pulse of the multi pulse train when the previous space was a 3T space for recording at reference velocity. The value is expressed in fractions of the channel bit clock period according to Fig. 8.

5 **Byte 48 - Ttop (≥4) first pulse duration for current mark ≥4 at maximum velocity.**

This byte shall specify the duration of the first pulse of the multi pulse train when the current mark is a 4T or greater mark for recording at maximum velocity. The value is expressed in fractions of the channel bit clock period as a number n such that

$$10 \quad n = 16 \times \frac{T_{top}}{T_w} \quad \text{and} \quad 4 \leq n \leq 40$$

Byte 49 - Ttop (3) first pulse duration for current mark =3 at maximum velocity.

This byte shall specify the duration of the first pulse of the multi pulse train when the current mark is a 3T mark for recording at maximum velocity. The value is expressed in fractions of the channel bit clock period as a number n such that

$$15 \quad n = 16 \times \frac{T_{top}}{T_w} \quad \text{and} \quad 4 \leq n \leq 40$$

Byte 50 - Tmp multi pulse duration at maximum velocity.

This byte shall specify the duration of the 2nd pulse through the 2nd to last pulse of the multi pulse train for recording at maximum velocity. The value is expressed in fractions of the channel bit clock period as a number n such that

$$20 \quad n = 16 \times \frac{T_{mp}}{T_w} \quad \text{and} \quad 4 \leq n \leq 16$$

Byte 51 - Tlp last pulse duration at maximum velocity.

This byte shall specify the duration of the last pulse of the multi pulse train for recording at maximum velocity. The value is expressed in fractions of the channel bit clock period as a number n such that

$$25 \quad n = 16 \times \frac{T_{lp}}{T_w} \quad \text{and} \quad 4 \leq n \leq 24$$

Byte 52 - dTtop first pulse lead time at maximum velocity.

This byte shall specify the lead time of the first pulse of the multi pulse train relative to the trailing edge of the second channel bit of the data pulse for recording at maximum velocity. The value is expressed in fractions of the channel bit clock period as a number n such that

$$n = 16 \times \frac{dT_{top}}{T_w} \quad \text{and} \quad 0 \leq n \leq 24$$

Byte 53 - dTle first pulse leading edge correction for previous space =3 at maximum velocity.

5 Bit 7 to bit 4 of this byte shall specify the leading edge correction for the 1st pulse of the multi pulse train when the previous space was a 3T space for recording at maximum velocity. The value is expressed in fractions of the channel bit clock period according to Fig. 8.

Bytes 54 to 63 - Reserved - All (00).

These bytes shall be set to all (00).

10 **Bytes (64 + i×32) to (95 + i×32) – Extended Information block i (i = 0..5)**

To facilitate future extensions, Extended Information blocks are introduced. Each such block consists of 32 bytes. These bytes can hold for instance parameters for an alternative write strategy, e.g. for High-Speed recording, or other advanced parameters. The presence of an Extended Information block shall be indicated by a bit in byte 18.

15 Byte (64 + i×32) Extended Information block i version number indicates the block version and identifies the definitions of the data in bytes (64 + i×32) to (95 + i×32). A disc can have several Extended Information blocks of which the block version numbers can be the same as well as different.

20 Drives not acquainted with the specific block version number in block i, should not use the disc with the advanced parameters in this Extended Information block.

If the block version number is set to 255, the related Extended information block is not an independent block but a continuation of the preceding Extended Information block (to be used if 32 bytes are not sufficient for a set of parameters).

Bytes (65 + i×32) to (95 + i×32)

these bytes can be used to hold alternative write strategies or other parameters.

Example for High-speed write strategy parameters

30 Byte 18 : 0000 0001 indicating Extended Information block 0 is in use.

Byte 64 : 0000 0001 indicating block version 1, for which bytes 65 to 95 have the following meaning:

Byte 65 : Maximum recording velocity for the parameter set in this EI block:

- $n \times 0,25 \text{ m/s}$, (max $\leq 63,75 \text{ m/s} = 18.25x = 175 \text{ Hz @ R} = 58 \text{ mm}$)
- Byte 66 : Minimum recording velocity for the parameter set in this EI block:
 $n \times 0,25 \text{ m/s}$, (minimum recording velocity is allowed to be = maximum recording velocity)
- 5 Byte 67 : reserved and set to (00)
- Byte 68 to 81 : parameter set for maximum recording velocity
- byte 68: PIND
- byte 69: β_{target}
- byte 70: $T_{\text{top}} (\geq 4)$ first pulse duration for $\text{cm} \geq 4$
- 10 byte 71: $T_{\text{top}} (=3)$ first pulse duration for $\text{cm} = 3$
- byte 72: T_{mp} multi pulse duration
- byte 73: T_{lp} last pulse duration
- byte 74: $dT_{\text{top}} (\geq 4)$ first pulse lead time for $\text{cm} \geq 4$
- byte 75: $dT_{\text{top}} (=3)$ first pulse lead time for $\text{cm} = 3$
- 15 byte 76: dT_{le} 1st pulse leading edge correction for $\text{ps} = 3$
- byte 77: dT_{le} 1st pulse leading edge correction for $\text{ps} = 4$
- byte 78: reserved and set to (00)
- byte 79: reserved and set to (00)
- byte 80: reserved and set to (00)
- 20 byte 81: reserved and set to (00)
- Byte 82 to 95 : parameter set for minimum recording velocity
- byte 82: PIND
- byte 83: β_{target}
- byte 84: $T_{\text{top}} (\geq 4)$ first pulse duration for $\text{cm} \geq 4$
- 25 byte 85: $T_{\text{top}} (=3)$ first pulse duration for $\text{cm} = 3$
- byte 86: T_{mp} multi pulse duration
- byte 87: T_{lp} last pulse duration
- byte 88: $dT_{\text{top}} (\geq 4)$ first pulse lead time for $\text{cm} \geq 4$
- byte 89: $dT_{\text{top}} (=3)$ first pulse lead time for $\text{cm} = 3$
- 30 byte 90: dT_{le} 1st pulse leading edge correction for $\text{ps} = 3$
- byte 91: dT_{le} 1st pulse leading edge correction for $\text{ps} = 4$
- byte 92: reserved and set to (00)
- byte 93: reserved and set to (00)

PHNL031178

PCT/IB2004/051727

14

byte 94: reserved and set to (00)

byte 95: reserved and set to (00)

The indicator can be implemented by using one or more bytes of the physical format information bytes. The value of these bytes indicates how optimal the write strategy is for the optical record carrier on which the indicator is stored.

For the different write velocities different write strategies are optimal. Also for one write velocity different write strategies can be applicable. A way to indicate for the different write velocity what write strategy is applicable is to use a byte [7..0] for each write velocity:

10 - Bits 7..4 describe the velocity (16 possible velocities)
 e.g. 0001 decodes for 1X (reference velocity)
 0111 decodes for 7X

- Bits 3..0 describe which write strategy (out of four in this case) applies
 e.g. 0101: WS1 and WS3 are applicable
 15 1000: WS4 is applicable

To describe which velocity is optimal at each velocity a byte per velocity is added:

- Bits 7..4 describe the velocity
 e.g. 0001 decodes for 1X (reference velocity)
 0111 decodes for 7X

20 - Bits 3..0 describe which velocity applies
 e.g. 0100: WS3 is optimal
 1000: WS4 is optimal

In step 1 (100) of Fig. 5 the write strategies contained in the optical record carrier which can be applied by the method are determined. In step 2 (101) the indicators of the applicable write strategies are read. Subsequently, in step 3 (102), the most optimal write strategy is determined. For instance, the write strategy with the highest indicator is the most optimal one. Of course, the write velocity is also taken into account, i.e. only the write strategies which are applicable for the write velocity at which the information should be written are taken into account. Finally, in step 4 (103), the pits and lands are formed by controlling the radiation source with the determined optimal write strategy.

2004275083 07 Jul 2010

It will be appreciated by persons skilled in the art that numerous variations and/or modifications may be made to the invention as shown in the specific embodiments without departing from the scope of the invention as broadly described. The present embodiments are, therefore, to be considered in all respects
5 as illustrative and not restrictive.

CLAIMS:

1. An optical record carrier recording method for forming pits and lands by controlling a radiation source to direct a radiation beam onto a recording surface of an optical record carrier, the method comprising the steps of:
- 5 reading a write strategy from the optical record carrier which comprises at least two write strategies, and
- forming the pits and lands by controlling the radiation source with the read write strategy,
- 10 wherein the method further comprises a step of determining which of the at least two write strategies is the most optimal one by reading an indicator present on the optical record carrier, and wherein the method uses the most optimal write strategy to form the pits and the lands,
- wherein the indicator further indicates in which order the write strategies are preferred for the optical record carrier on which the indicator is stored, that the method is capable of determining which of the write strategies can be applied by the method and that the method determines from the applicable write strategies which is the most optimal one, the method thereby using the order of preference indicated by the indicator.
- 15
2. An optical record carrier recording method as claimed in claim 1, wherein the method concludes from a sequential order in which the at least two write strategies are stored on the optical record carrier which write strategy is the most optimal one.
- 20
3. An optical record carrier recording method as claimed in claim 1, wherein the method determines the most optimal write strategy by reading additional information stored the optical record carrier.
- 25
4. An optical record carrier recording method as claimed in claim 3, wherein the method reads the additional information from in a Control Data Zone present in a lead-in zone of the optical record carrier.
- 30
5. An optical record carrier recording method as claimed in claim 3 or 4, wherein the method reads an additional byte contained in the write strategies which additional byte describes a write velocity for which the write strategy can be
- 35

applied and wherein the method reads the additional information by reading an additional bit or byte contained in the write strategies which indicates if the write strategy is the most optimal one for that write velocity.

- 5 6. An optical record carrier comprising at least two write strategies, wherein the optical record carrier further comprises an indicator which of the at least two write strategies is the most optimal one,
wherein the indicator further indicates in which order the write strategies are preferred for the optical record carrier on which the indicator is stored.
- 10 7. An optical record carrier as claimed in claim 6, wherein a sequential order in which the at least two write strategies are stored on the optical record carrier indicate which write strategy is the most optimal one.
- 15 8. An optical record carrier as claimed in claim 6, wherein additional information stored on the optical record carrier indicates which write strategy is the most optimal one.
- 20 9. An optical record carrier as claimed in claim 8, wherein the additional information is stored in a Control Data Zone present in a lead-in zone of the optical record carrier.
- 25 10. An optical record carrier as claimed in claim 8 or 9, wherein the write strategies contain an additional byte describing a write velocity for which the write strategy can be applied and an additional bit or by indicating if the write strategy is the most optimal one for that write velocity.
- 30 11. An optical record carrier as claimed in claim 8, 9 or 10, further comprising at least two additional bytes wherein each byte indicates for a write velocity which of the write strategies may be applied for that write velocity and wherein the optical record carrier further comprises at least two further additional bytes each byte indicating for a write velocity which of the write strategies is the most optimal one.
- 35 12. An apparatus for writing information to an optical record carrier, comprising:
a write head for generating a radiation beam and directing the beam onto a

recording surface of the optical record carrier,

reading means for reading a write strategy from the optical record carrier which comprises at least two write strategies and for reading an indicator which of the at least two write strategies is the most optimal one,

5 a write head controller for controlling the write head with the read write strategy for forming pits and lands,

a processor for controlling the apparatus, the processor being capable of determining which of the at least two write strategies is the most optimal one from the read indicator,

10 wherein the write head controller is capable of using the most optimal write strategy to form the pits and the lands,

wherein the indicator further indicates in which order the write strategies are preferred for the optical record carrier on which the indicator is stored, that the processor is capable of determining which of the write strategies can be applied by the write head controller and that the processor determines from the applicable write strategies which is the most optimal one, the processor thereby using the order of preference indicated by the indicator.

13. An optical record carrier recording method for forming pits and lands by controlling a radiation source to direct a radiation beam onto a recording surface of an optical record carrier substantially as hereinbefore described with reference to the accompanying drawings.

14. An optical record carrier comprising at least two write strategies substantially as hereinbefore described with reference to the accompanying drawings.

15. An apparatus for writing information to an optical record carrier substantially as hereinbefore described with reference to the accompanying drawings.

30

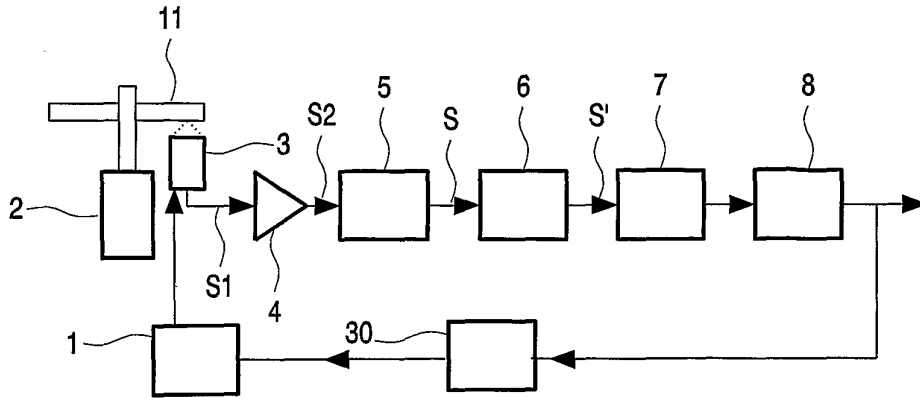

FIG. 1

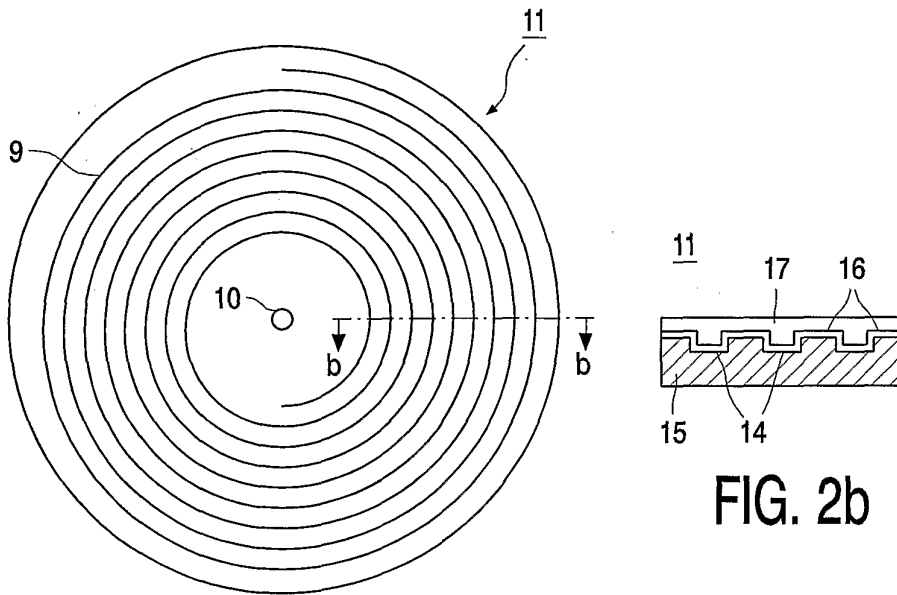

FIG. 2a

FIG. 2b

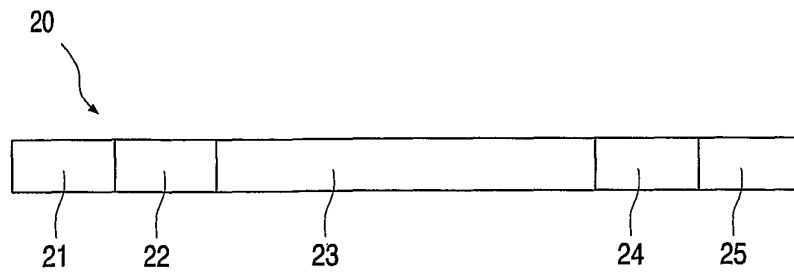

FIG. 3

Byte number	Content	Number of bytes
0	Disc Category and Version Number: indicates the version of the disc and identifies the definitions of the data in bytes 0 to 63 (important for backwards compatibility). Drives not acquainted with the specific Version Number of a disc should not try to record on that disc using the information in bytes 0 to 63.	1
1	Disc size	1
2	Disc structure	1
3	Recording density	1
4 to 15	Data Zone allocation	12
16	Set to (00)	1
17	Reserved – All (00)	1
18	Extended Information indicators	1
19 to 26	Disc Manufacturer ID	8
27 to 29	Media type ID	3
30	Product revision number	1
31	number of Physical format information bytes in use in ADIP up to byte 63 (according to first generation: set to 56)	1
32	Reference recording velocity	1
33	Maximum recording velocity	1
34	Wavelength λ_{IND}	1
35	normalized Write power dependency on Wavelength $(dP/d\lambda)/(P_{IND}/\lambda_{IND})$	1
36	Maximum read power at reference velocity	1
37	P_{IND} at reference velocity	1
38	β_{target} at reference velocity	1
39	Maximum read power at maximum velocity	1
40	P_{IND} at maximum velocity	1
41	β_{target} at maximum velocity	1
42	$T_{top} (\geq 4)$ first pulse duration for $cm \geq 4$ at reference velocity	1
43	$T_{top} (=3)$ first pulse duration for $cm = 3$ at reference velocity	1
44	T_{mp} multi pulse duration at reference velocity	1
45	T_{lp} last pulse duration at reference velocity	1
46	$dT_{top} (\geq 4)$ first pulse lead time for $cm \geq 4$ at reference velocity	1
47	$dT_{top} (=3)$ first pulse lead time for $cm = 3$ at reference velocity	1
48	dT_{le} 1 st pulse leading edge correction for $ps = 3$ at reference velocity	1
49	$T_{top} (\geq 4)$ first pulse duration for $cm \geq 4$ at maximum velocity	1
50	$T_{top} (=3)$ first pulse duration for $cm = 3$ at maximum velocity	1
51	T_{mp} multi pulse duration at maximum velocity	1
52	T_{lp} last pulse duration at maximum velocity	1
53	$dT_{top} (\geq 4)$ first pulse lead time for $cm \geq 4$ at maximum velocity	1
54	$dT_{top} (=3)$ first pulse lead time for $cm = 3$ at maximum velocity	1
55	dT_{le} 1 st pulse leading edge correction for $ps = 3$ at maximum velocity	1
56 to 63	Reserved – All (00)	8
64 to 95	Extended Information block 0	32
96 to 127	Extended Information block 1	32
128 to 159	Extended Information block 2	32
160 to 191	Extended Information block 3	32
192 to 223	Extended Information block 4	32
224 to 247	Extended Information block 5	24
248 to 255	Reserved for use in the Control Data Zone– All (00)	8

FIG. 4

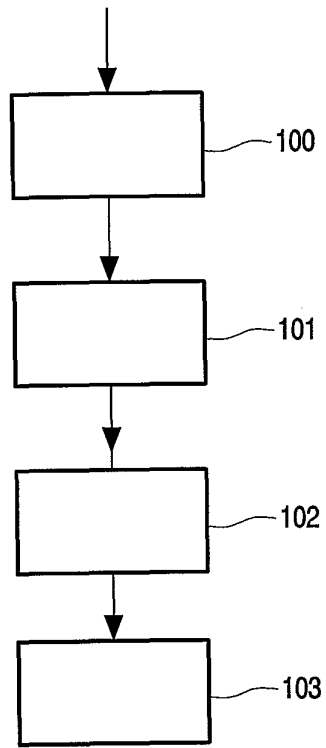

FIG. 5