

S. J. Parmele,

Lifting Jack.

N^o 51,963.

Patented Jan. 9, 1866.

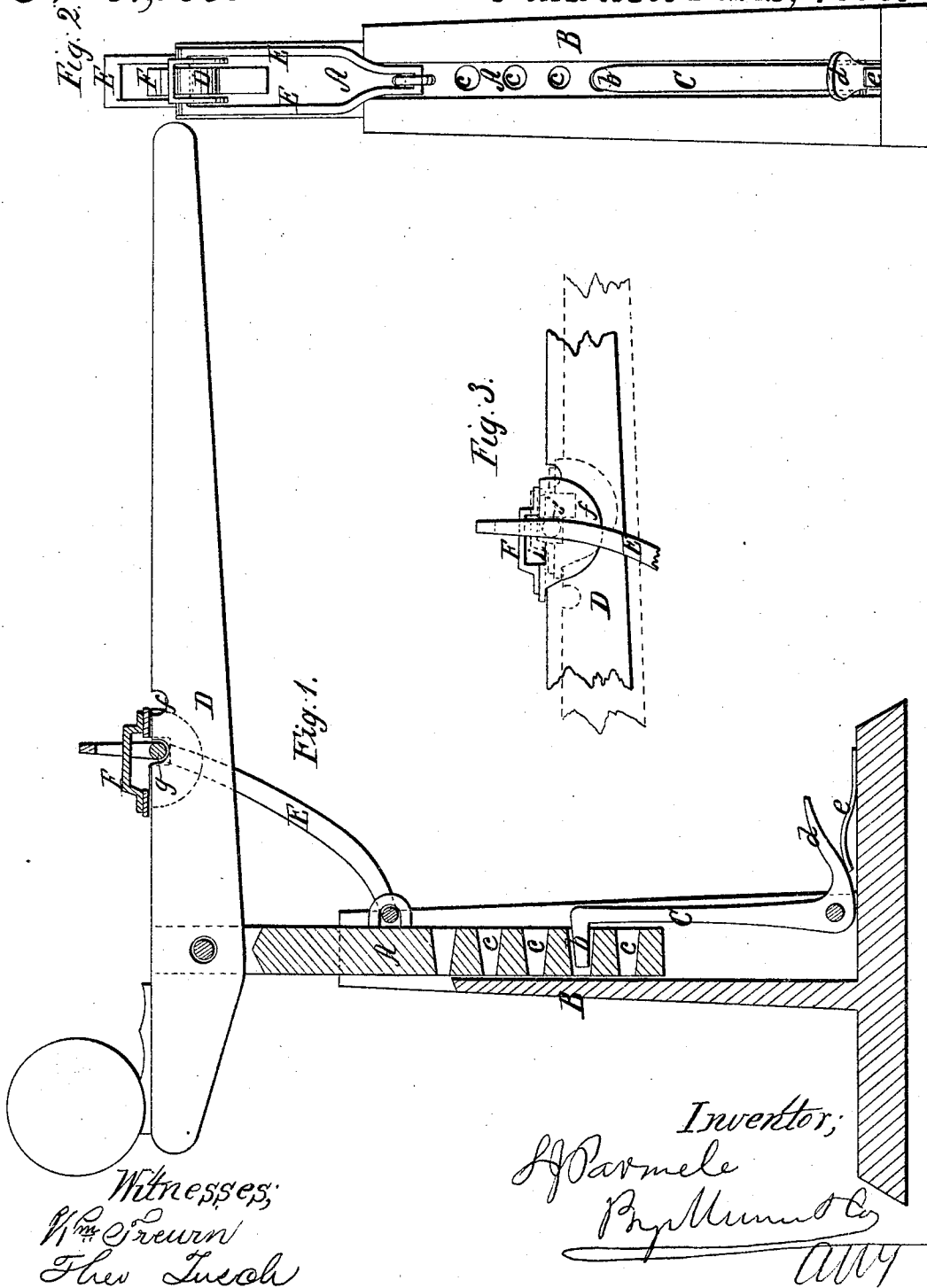

Witnesses;
Wm Greun
Flew Tusch

Inventor;
S. J. Parmele
By Munn & Co
Attys

UNITED STATES PATENT OFFICE.

S. J. PARMELE, OF KILLINGWORTH, CONNECTICUT.

IMPROVED LIFTING-JACK.

Specification forming part of Letters Patent No. 51,963, dated January 9, 1866.

To all whom it may concern:

Be it known that I, S. J. PARMELE, of Killingworth, in the county of Middlesex and State of Connecticut, have invented a new and Improved Lifting-Jack; and I do hereby declare that the following is a full, clear, and exact description thereof, which will enable others skilled in the art to make and use the same, reference being had to the accompanying drawings, forming part of this specification, in which—

Figure 1 is a side elevation of my lifting-jack, partly in section. Fig. 2 is a front view of the same.

Similar letters of reference indicate like parts.

My invention consists in the use, in connection with the lifting-bar and locking-bar of a carriage-jack, of a slide of peculiar construction, whereby the adjustment or locking of the lifting-bar is greatly facilitated; and it also consists in a novel arrangement, in combination with the other parts of the jack, of the catch-lever or pawl for holding the rack-bar at the desired height, as will be presently described.

To enable others to understand my invention, I will proceed to describe it.

A represents the rack-bar of the jack. It is arranged to slide up and down in a case or guiding-frame, B, in the usual or any suitable manner.

C is a pawl or catch-lever, which is pivoted to the case B at the bottom of a vertical slot. (See Fig. 2.) This catch-lever has a bent end, *b*, which, when the rack-bar is to be raised, catches into holes *c* made therein along its length for the purpose of regulating the height or "setting the jack," as it is called, and this catch-lever carries on its lower end a foot-pad, *d*, on which the foot can be placed when it is desired to withdraw the end *b* of the catch-lever from the holes in the rack-bar to allow the rack-bar to be raised, and a spring, *e*, is arranged under the end of the catch-lever, for keeping the end *b* always pressed against the rack-bar, so as to catch into one of the holes therein so soon as the foot is removed.

D is the lifting-lever, which is secured to the rack-bar in the usual way or any suitable way. This lifting-lever has notches *f f* cut into its upper edges for a suitable distance, which are intended for receiving a rod, *g*, extending across the locking-bar E at its upper end. This locking-bar, in the present instance,

consists of two arms pivoted to the case B, as shown in Fig. 2, and separated sufficiently to allow of the lifting-lever passing between the two arms. A slide, F, is used in connection with this locking-bar. Its shape is shown clearly in Fig. 3. It rides on the top of the locking-bar, its flanges or lips extending down each side, and a slot is cut in them of such form that one part shall be deeper than the other.

When it is not desired to have the rod *g* catch into the notches the said rod rides on the part *i* of the slide, and is thus enabled to slide over the notches to the one where it is intended that it shall rest, when, by a slight elevation or depression of the lifting-lever, the rod will drop off into the part *j* and will immediately catch into the desired notch. Again, when it is desired to release the lifting-lever to lower the carriage-axle, a slight depression of the lifting-lever will throw the rod *g* upon the part *i* of the slide, when it will be again caused to slide over the notches in the lifting-lever.

The operation of this jack is very simple, and it requires but very little manipulation to adjust it for use.

To use the jack the foot is placed upon the foot-pad *d*, which releases the rack-bar. The rack is then raised by raising upward the lifting-lever until the shorter end of the lifting-lever, when fully depressed, just reaches the axle of the carriage. The foot is then removed and the rack-bar locked in such position. Now, by depressing the handle of the lever the wheel will be raised, and, the rod *g* catching in the proper notch on the lifting-lever, the axle will be held firmly at the desired height.

By this invention I provide a very simple and strong lifting-jack, and one which can be easily and quickly adapted for use and as quickly withdrawn from the carriage-axle.

What I claim as new, and desire to secure by Letters Patent, is—

1. The slide F, in combination with the lifting-lever D and locking-bar E, substantially as and for the purpose specified.

2. The combination of the catch-bar C and spring *e* with the rack-bar A and lifting-lever D and locking-bar E, substantially as shown and described.

S. J. PARMELE.

Witnesses:

NORMAN L. PARMELE,
NEWEL C. DAVIS.