

E. T. STARR.
DENTAL ENGINE.

No. 276,299.

Patented Apr. 24, 1883.

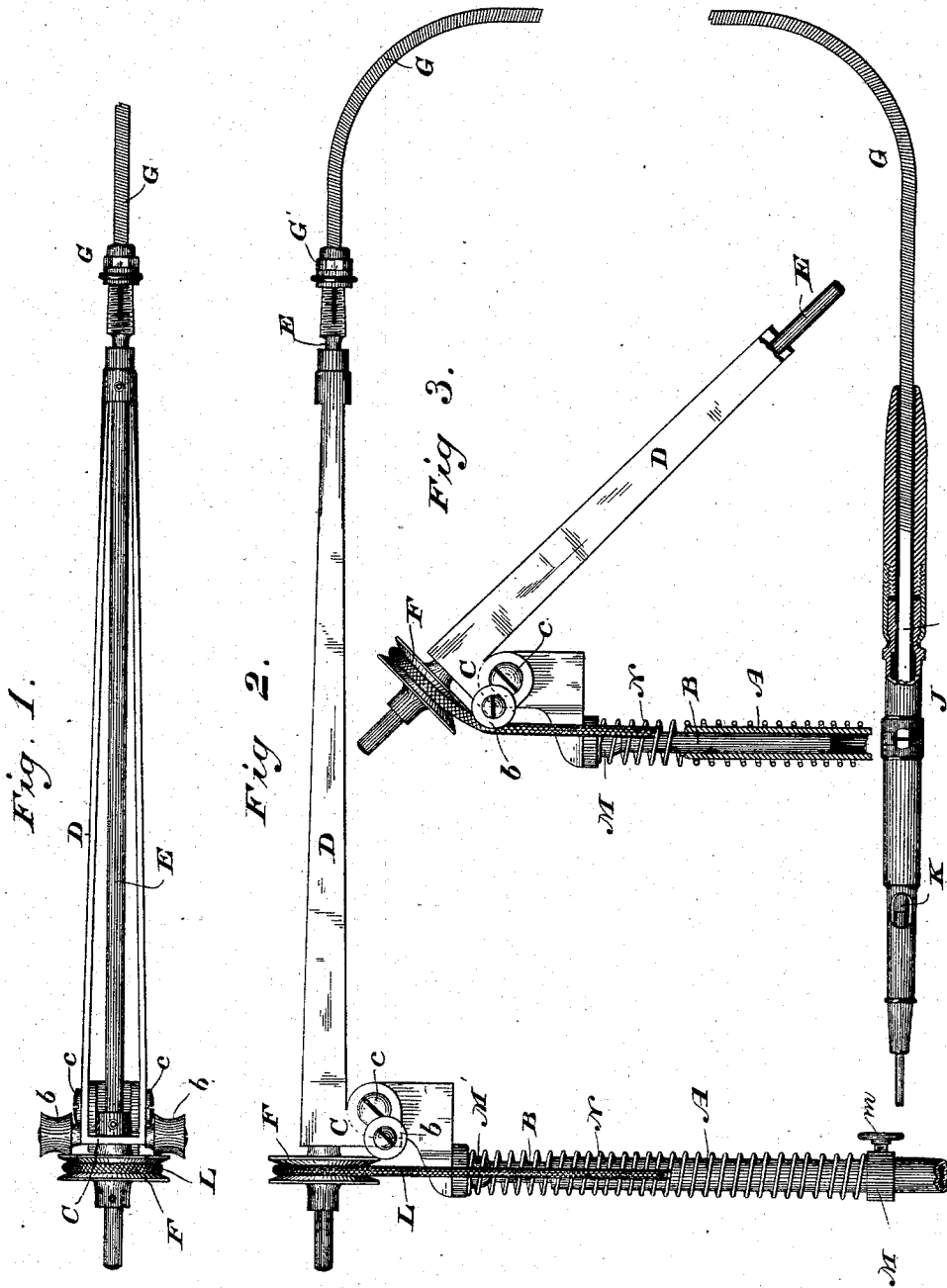

WITNESSES

Wm. A. Shinkle
Geo. W. Beck

INVENTOR

Eli. T. Starr.

By his Attorneys

Baldwin, Hopkins, & Peyton

E. T. STARR.

DENTAL ENGINE.

No. 276,299.

Patented Apr. 24, 1883.

Fig A.

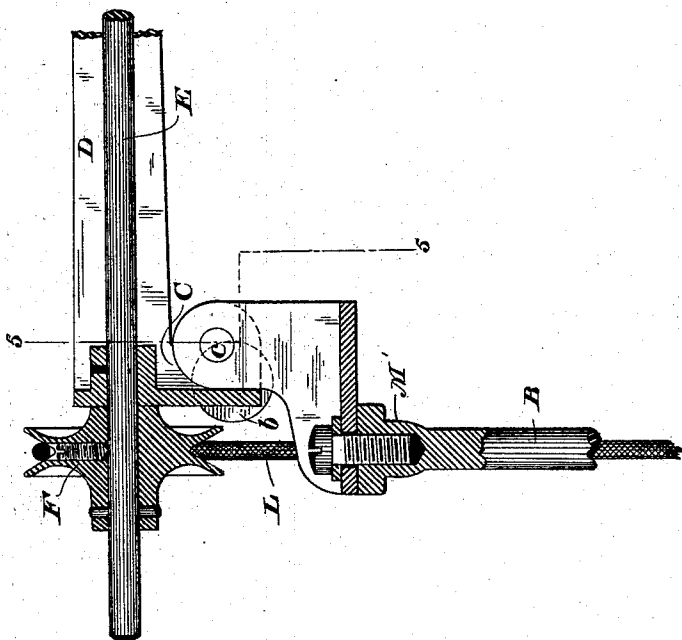
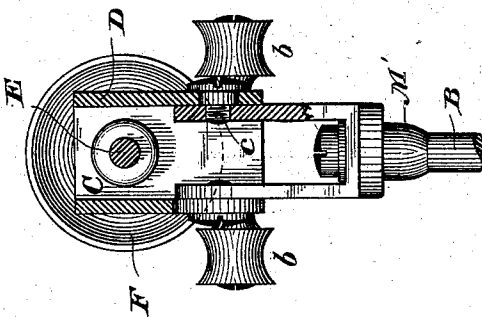

Fig B.



WITNESSES

Wm A. Skinkle
Geo W. Buck

INVENTOR

Eli. T. Starr.

By his Attorneys

Baldwin, Hopkins, & Peyton.

E. T. STARR.

DENTAL ENGINE.

No. 276,299.

Patented Apr. 24, 1883.

Fig. 6.

Fig. 7.

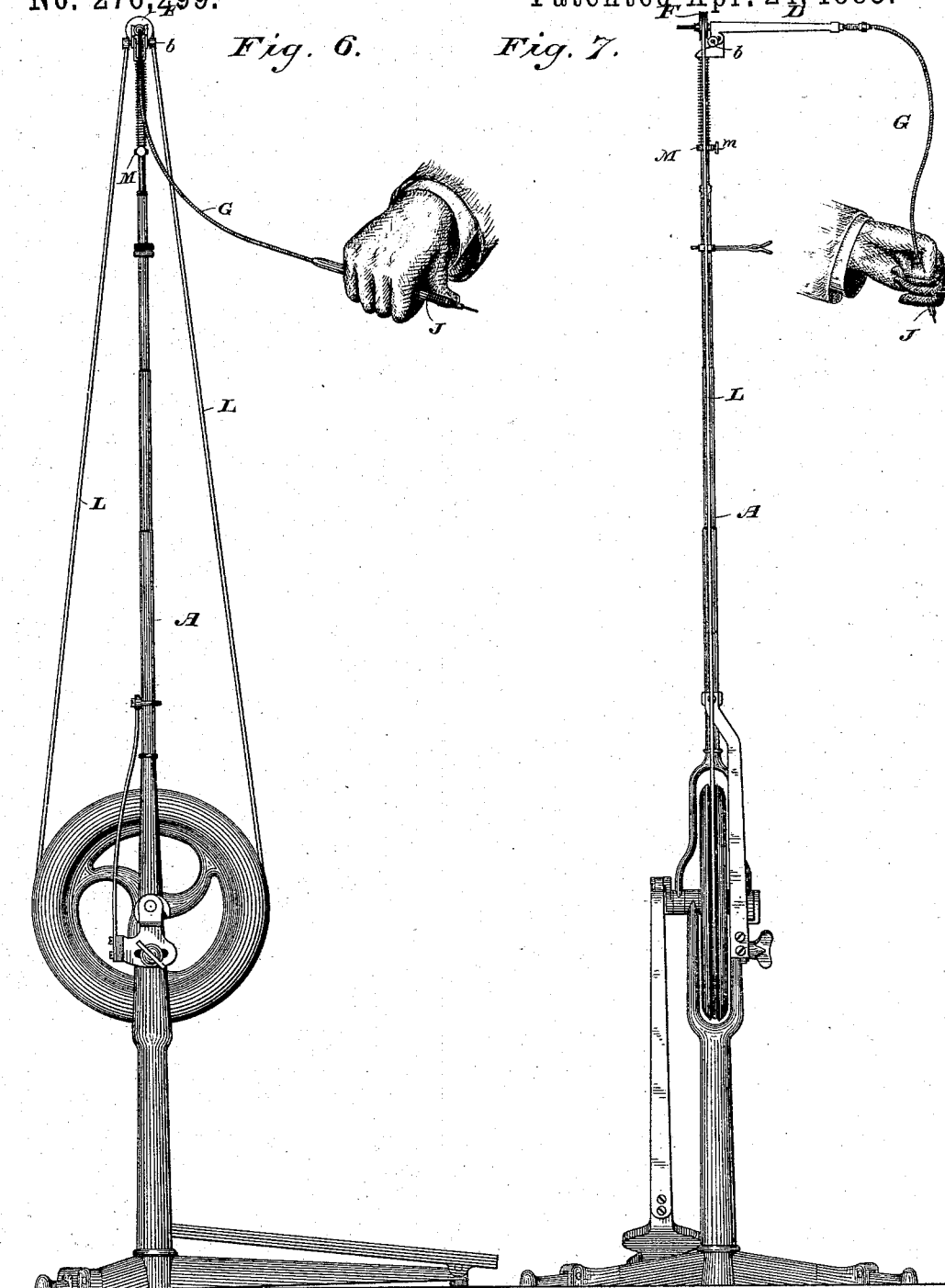

WITNESSES

INVENTOR

Wm A. Skinkels.
Geo W. Brock.

Eli. T. Starr.
 By his Attorneys
Baldwin, Hopkins, & Peyton.

E. T. STARR.
DENTAL ENGINE.

No. 276,299.

Patented Apr. 24, 1883.

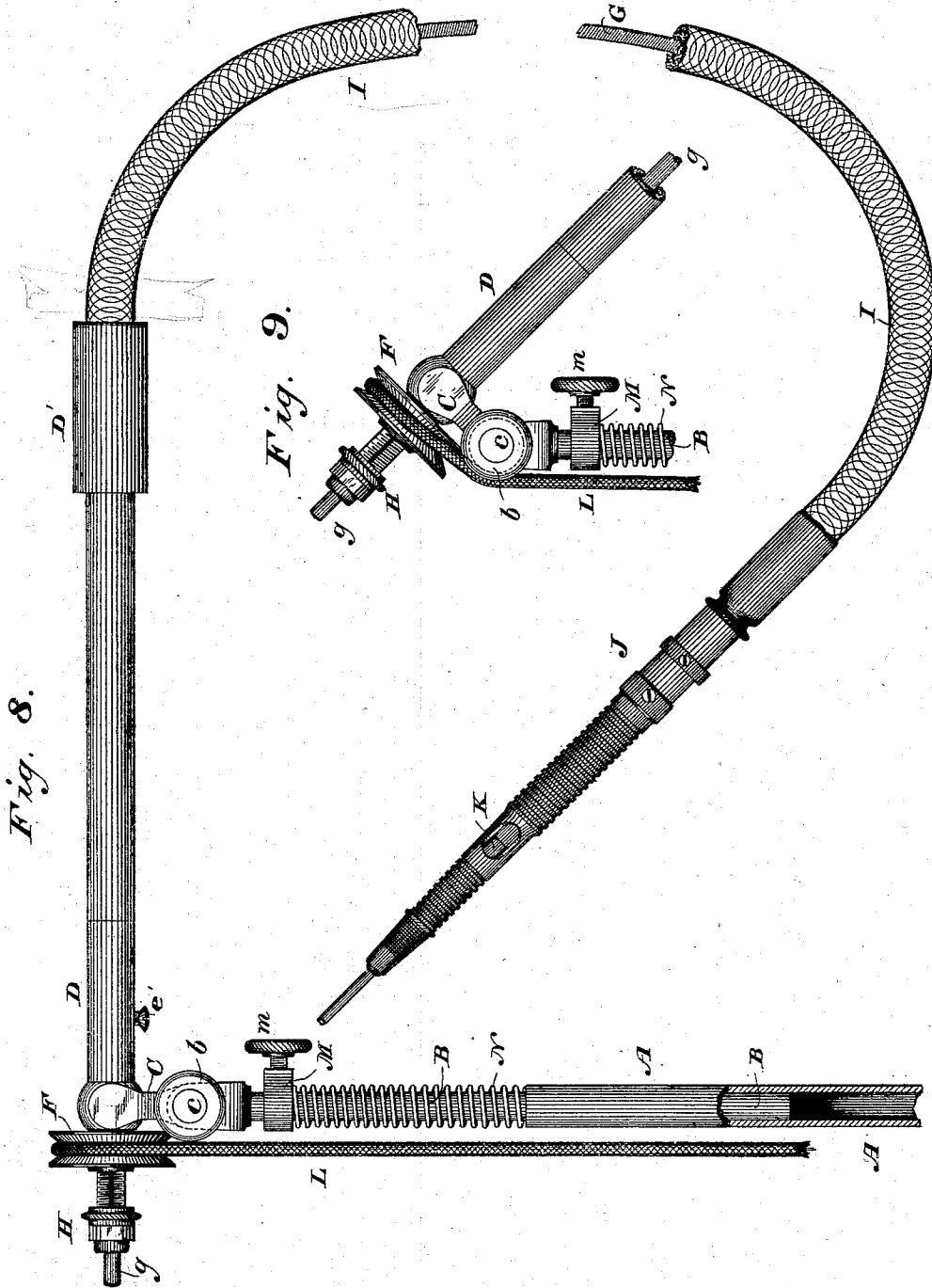

Fig. 8.

Fig. 9.

WITNESSES

Wm A Shinkle.
Geo W Buck.

INVENTOR

Eli T. Starr.

By his Attorneys

Baldwin, Hopkins, & Peyton.

E. T. STARR.
DENTAL ENGINE.

No. 276,299.

Patented Apr. 24, 1883.

Fig. 10.

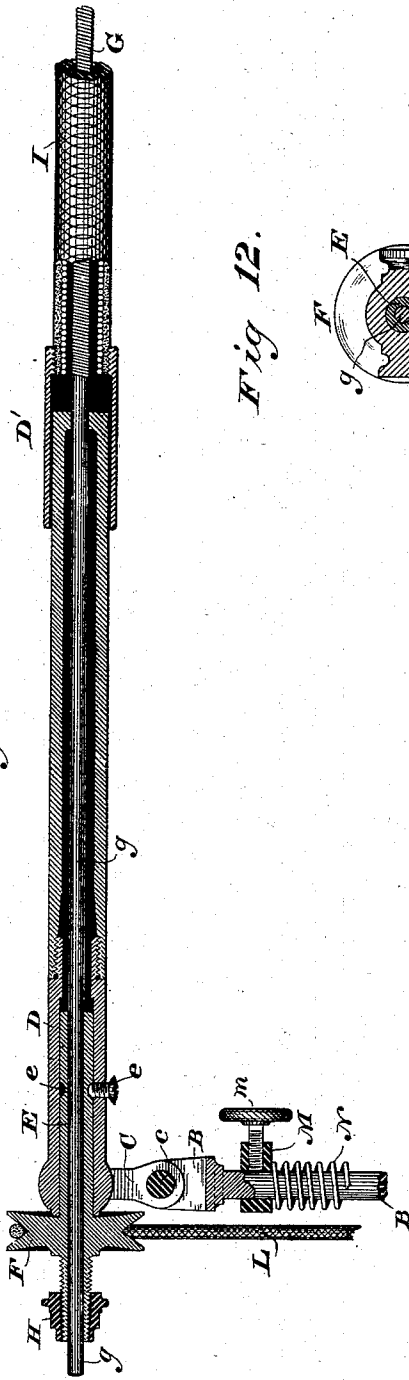

Fig. 12.

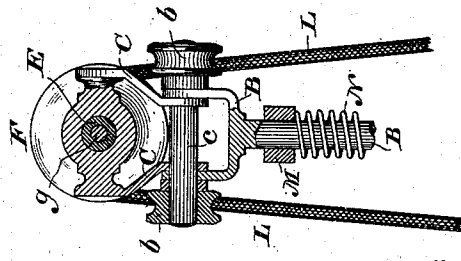
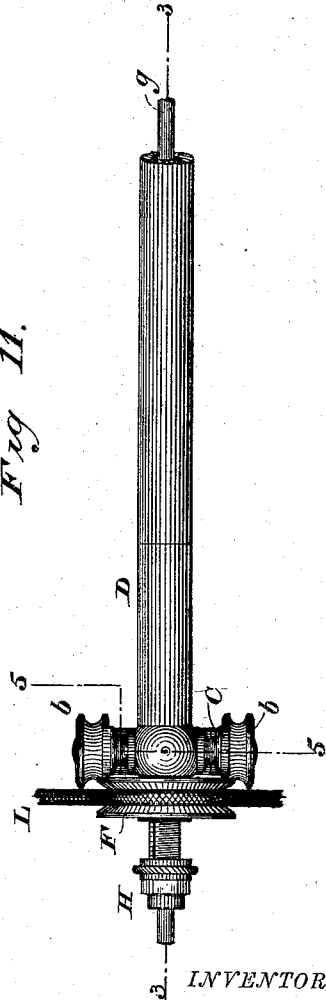

Fig. 11.



WITNESSES

Wm A Skinkle
Geo W Brock

By his Attorneys

Baldwin Hopkins, & Peyton.

INVENTOR
Eli T Starr

E. T. STARR.
DENTAL ENGINE.

No. 276,299.

Patented Apr. 24, 1883.

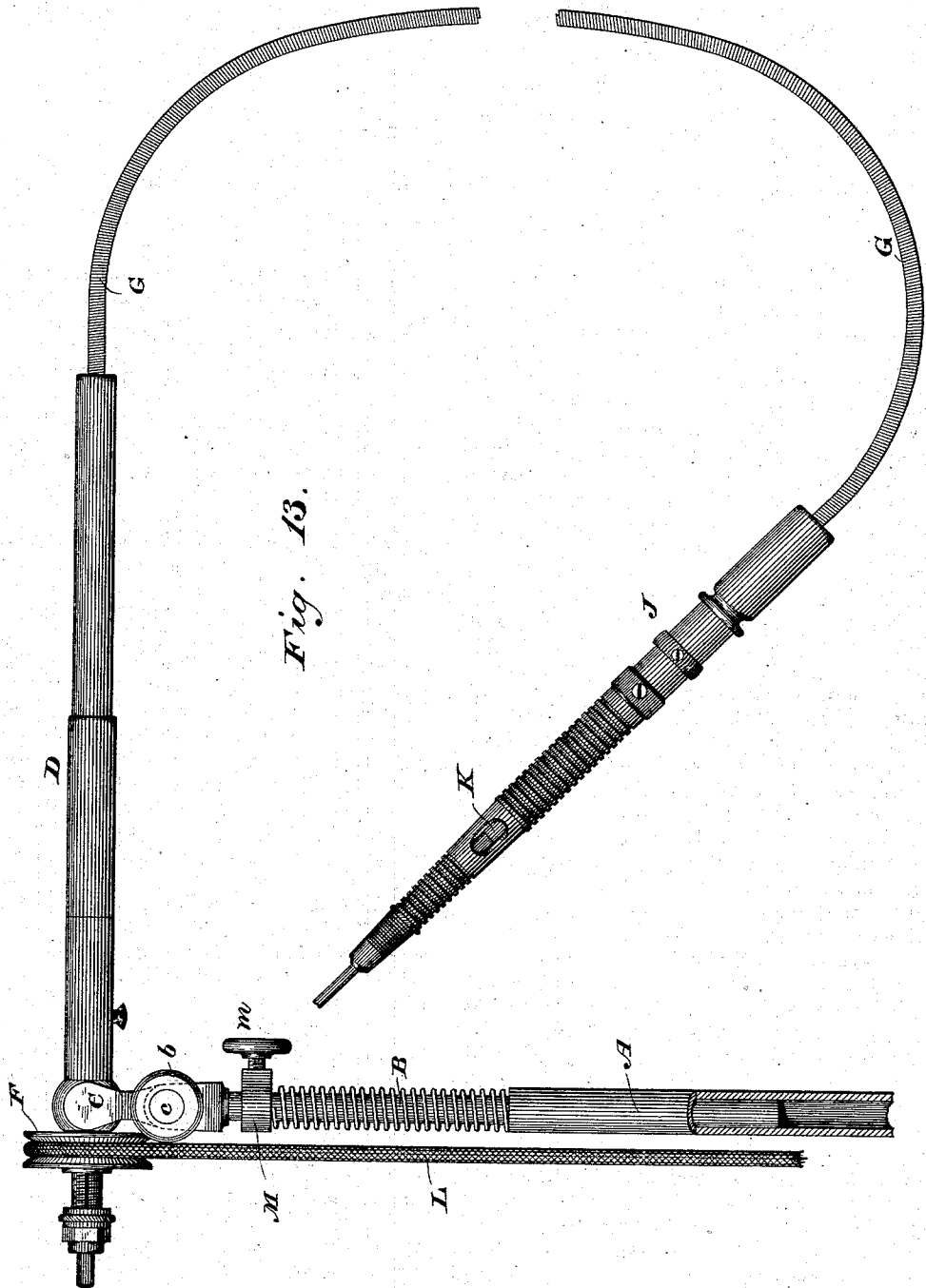

Fig. 13.

WITNESSES

Wm A. Skinkle.
Geo W. Beck.

INVENTOR

Eli. T. Starr.
By his Attorneys
Baldwin, Hopkins, & Peyton

UNITED STATES PATENT OFFICE.

ELI T. STARR, OF PHILADELPHIA, PENNSYLVANIA, ASSIGNOR TO SAMUEL S. WHITE, OF SAME PLACE.

DENTAL ENGINE.

SPECIFICATION forming part of Letters Patent No. 276,299, dated April 24, 1883.

Application filed June 27, 1879. Patented in England August 13, 1879, No. 3,262.

To all whom it may concern:

Be it known that I, ELI T. STARR, of the city and county of Philadelphia, in the State of Pennsylvania, have invented certain new and useful Improvements in Dental Engines, of which the following is a specification.

My invention relates more especially to dental engines of the class comprising in their structure a base or stand carrying a foot-treadle and driving-pulley, an arm or frame rising from the base, a driven pulley connected with the upper end of the engine-arm, a belt-connection between the driving and driven pulleys, and a flexible power-conveyer receiving motion from the driven pulley and imparting motion to the operating-tool mounted in a handle or hand-piece, the hand-piece being free to be moved about in various directions to operate at different points in the patient's mouth.

The object of my present invention is to give great freedom of movement to the hand-piece and operating-tool carried thereby, and also to the flexible power-conveyer or shaft relatively to the engine-arm without interrupting the transmission of the driving-power, which ends I attain by means of certain new combinations of devices, which will hereinafter be specifically designated, and then pointed out at the close of the specification.

In the accompanying drawings, which show my improvements as embodied in the best way now known to me, Figure 1 is a plan or top view of the improved engine-head; Fig. 2, a side view thereof, showing the upper works of the engine, including the flexible power-conveyer and hand-piece, the latter being partly in section; Fig. 3, a side view, partly in section, showing the head as rocked to a position different from that shown in Fig. 2; Fig. 4, a longitudinal vertical section through the apparatus; Fig. 5, a transverse section there-through on the line 5 5 of Fig. 4. Figs. 6 and 7 represent, respectively, a side and back view of a complete engine embodying my improvements. Fig. 8 is a view in elevation of the upper works of a dental engine embodying my improvements in a modified form—that is, in a form different from that shown in the preceding figures—the flexible power-conveyer being shown as enveloped and protected by a flexible sheath or cover; Fig. 9, a similar view

thereof, the rocking engine-head being in a different position from that shown in Fig. 8 and the flexible power-conveyer broken away; Fig. 10, a longitudinal central section through the modified form of apparatus on the line 3 3 of Fig. 11; Fig. 11, a plan or top view thereof; Fig. 12, a vertical section therethrough on the line 5 5 of Fig. 11; and Fig. 13, a view of the apparatus similar to that shown in Fig. 8, but with the enveloping-sheath or cover for the flexible shaft or power-conveyer omitted.

The base, the standard rising therefrom, the treadle, and the lower parts of the engine, as shown in Figs. 6 and 7, together with the rocking engine-arm A, are shown as of an improved form of construction and organization, not necessary to be here described with minuteness or in detail, as the invention embodied therein and thereby is fully shown, described, and claimed by me in an application for Letters Patent of the United States filed February 1, 1879, and, moreover, such detail description is not necessary to a proper understanding of the subject-matter claimed herein, the said parts being illustrated with the object more especially of showing my present improvements as embodied and organized in a complete dental engine ready for use.

The engine-arm A, which may be connected with the standard rigidly, or so as to rock to and fro, is shown as tubular for the reception of the pivotal shank, journal, or spindle B of the engine-head or lateral arm, so that said head may turn or swivel freely horizontally around or upon the engine-arm, as usual. The upper end of said pivotal shank B is forked, branched, or provided with a yoke, as clearly shown in Figs. 1, 5, and 12, the upper ends of the arms of the said yoke or fork receiving the pivot-bolt or pivots *c* of the crosswise pivotal connection which connects the lateral arm or engine-head D with the engine-arm A, with the capacity of rocking or vibrating freely relatively to the engine-arm and to the shank, hereinafter described.

In the form of engine shown in Figs. 1 to 7, inclusive, the engine-head or lateral arm D has the form of a frame provided at its butt with a yoke, C, whose branches are connected with the pivots *c*, before mentioned, and this arm carries in suitable bearings a shaft or spin-

dle, E, said shaft having a pulley, F, mounted upon it, which constitutes the driven pulley of the engine, and imparts the required rotary motion to the said spindle when driven by the belt-connection running from the driving-pulley, hereinafter fully described. The outer end of this driven spindle or shaft E is socketed preferably for the reception of the inner end of the flexible power conveyer or shaft G, said inner end of the conveyer being inserted in the socket and secured therein. The driven spindle and flexible shaft are shown as secured together by a clamp, the walls of the socket being split, so as to form spring clamping-jaws, which are compressed upon the flexible shaft or its inner stiff section, *g*, by means of a screw-nut, G', which works upon suitable threads formed upon the inclined or tapering circumference of the walls of said socket, as clearly illustrated in the drawings.

The flexible power-conveyer, which preferably consists of a coiled-wire shaft such as are in common use, is connected at its outer or free end with a suitable chuck, mandrel, or tool-holder, K, of any suitable construction, so as to turn it, said tool-holder being mounted in suitable bearings in a hand-piece casing, J, and being also adapted for the ready interchange of the operating-tools used with this class of engines in performing dental operations.

In the form of apparatus shown in Figs. 8 to 13, inclusive, the engine-head or lateral arm has the form of a tube, D, fitted at its butt with a yoke, C, forming a part of the rocking pivotal connection with the engine-arm A; although in this form of engine, as well as the form first described, the members of the pivotal connection which are connected by the pivot or pivots need not necessarily be of yoke form. This tubular lateral arm or engine-head D forms a bearing for the tubular journal E, the driven pulley F of the engine being firmly mounted upon or forming part of the said journal, which is locked from endwise movement in the bearing D by means of a circumferential groove, *e*, in which the end of a screw, *e'*—in this instance—fits after passing through said bearing D, as clearly shown in Fig. 10.

The inner end of the flexible power-conveyer G is preferably secured to the tubular journal E by means of its stiff section *g*, which is passed through the journal and clamped by a suitable nut, H, which works upon threads formed upon the tapering circumference of the split rear end of the tubular journal, as clearly shown.

The tubular lateral arm D has loosely mounted upon its end a telescoping ferrule, ring, or portion, D', secured or firmly connected to the inner end of the flexible sheath or cover I, such as those in common use, which envelops and protects the flexible power-conveyer. At the outer or free end of the flexible sheath is secured the hand-piece casing J, as clearly shown in Fig. 8, while the enveloped power-conveyer is connected with the butt-end of the tool-holder mounted in said hand-piece cas-

ing to turn it, as before stated. The object of the loose cylindrical telescopic connection D' between the hand-piece casing and the engine-head or lateral arm is to permit of slight endwise movement of the sheath relatively to the shaft during the flexure or bending of the shaft and sheath at work, whereby breakage, cramping, or straining of either the shaft or sheath is prevented. The tool-holder or spindle of the hand-piece is prevented from moving endwise in its bearings in the hand-piece casing as usual, and were the hand-piece casing connected rigidly with the engine-head by means of the enveloping-sleeve I, there would be great danger of straining and breaking the shaft or sheath, because during the flexure of the shaft and sheath in use one bends to a greater extent than the other; and to compensate this there should be a capability of slight endwise play of the sheath upon the shaft. This I attain by interposing between the hand-piece casing and the engine-head or lateral arm a loose telescopic joint, which, while it enables the hand-piece to be turned upon the spindle tool-holder to conform to the turning movements of the hand of the operator, also permits slight endwise play of the sheath, to avoid breakage or cramping and binding in the use of the engine.

In some instances I contemplate dispensing with the flexible sheath or cover for the power-conveyer in the form of head shown in Figs. 8 to 13, inclusive, in order to give more flexibility or freedom of movement to said power-conveyer, Fig. 13 showing the apparatus with the sheath removed.

The driving-belt L passes from the driving-pulley, at the lower end of the engine-arm, around the driven pulley F, which pulley, it will be observed, is mounted upon the spindle or shaft, or upon its journal E, carried by the engine-head or lateral arm, in such manner as to swing, vibrate, or rock around the pivots or pivot-bolt *c* as a center, the pivots or ends of the pivot-bolt projecting beyond the arms of the yoke or fork of the shank B, being provided with small guide-pulleys *b b* for the driving-belt, when the engine-head is rocked to a position requiring their aid, as in Figs. 3 and 9; or the said guide-pulleys may be mounted on independent pivots, if desired.

In order that the tension of the driving-belt may not be materially changed by the variation of position of the engine-head or lateral arm and pulley carried thereby when that head is rocked or turned, I preferably secure upon the upper end of the engine-arm A a collar or annular shoulder, M, fastened by a set-screw, *m*, and interpose between said collar and the annular shoulder or portion M', near the upper end of the turning shank B, next its yoke, a spiral spring, N, which tends to cause the shank B of the engine-head to slide endwise in the engine-arm. This shank-spring, it will be obvious, operates upon the engine-head and the driven pulley carried by it with a yielding pressure, and preserves the requisite

tension of the driving-belt connection in all the movements of said head.

In both of the above-described forms of engine it will be noticed that the driven pulley 5 F is arranged to overhang the pivot *c* of the rocking pivotal connection of the engine-head or lateral arm D, the said pulley being at the side of said pivot opposite that at which the arm extends, and the belt-connection L, when 10 in place, practically prevents the said pulley from rising, while the spring N, operating through the pivot *c*, tends to force the lateral arm upward. As this upward pressure is exerted between the driven pulley and the larger 15 portion of the lateral arm, the shank-spring exerting it counterbalances in whole or in part the downward pressure due to the weight of the lateral arm and its appurtenances, and causes it to stand out laterally from the engine-arm. 20

It will be obvious that the collar M may be reversed, as shown in Figs. 8, 9, 10, 12, and 13—that is, the said collar may be secured upon the upper end of the turning sliding shank 25 B, and the spring interposed between said collar and the top of the engine-arm in which the shank works; or the shank B may be tubular, and the spring may be inserted within it; or the spring may be inserted in a tubular cavity in the engine-arm A, and may operate 30 against the end of the shank B.

From the foregoing description it will be obvious that the hand-piece is given great freedom of movement not only by the flexure of 35 the flexible power-conveyer, but by the universal engine-head or lateral arm, which possesses the capacity of turning or swiveling horizontally and of rocking vertically, while at the same time the proper tension of the belt 40 is maintained and the weight of the rocking head is counterbalanced by the action of the shank-spring. The rocking arm or head and its appurtenances, when not in use, may also be rocked downward, so that the flexible power-conveyer will hang vertically and straight 45 at one side of the engine-arm, which position tends to prevent it from taking a set in a curved direction.

I am aware that rocking and turning or universal engine-heads are very common, and do not broadly claim such a device, limiting myself to the combinations of devices set out specifically in my claims.

I do not wish to be understood as claiming 55 herein, first, the combination of the lateral arm, the rocking pivot thereof, the shank of said arm, the shank-spring, the engine-arm, and the overhanging driven pulley carried by said lateral arm; nor, secondly, the combination of the lateral arm, the rocking pivot thereof, the pivotal shank of said arm, the shank-spring, the engine-arm, the overhanging driven pulley carried by said lateral arm, and the flexible power-conveyer driven by said pulley. 60 These two recited combinations are claimed in and form part of the subject-matter of my application for Letters Patent of the United

States filed subsequently to the present one—that is, August 22, 1879. I reserve, however, 70 as the subject-matter of my present application all other patentable subject-matter common to this and my application of August aforesaid.

I claim as my invention—

1. The combination, substantially as herein 75 before set forth, with an engine arm or support, of the lateral arm, the pivot crosswise of said arm, upon which said arm rocks, and the driven pulley overhanging said pivot at the side thereof opposite that at which said lateral 80 arm extends.

2. The combination, substantially as herein before set forth, with an engine arm or support, of the lateral arm, the rocking pivot crosswise of said arm, the driven pulley overhanging said pivot at the side thereof opposite that at which the lateral arm extends, 85 and the flexible power-conveyer driven by said pulley.

3. The combination, substantially as herein before set forth, of the lateral arm, the rocking pivot of said arm, the driven pulley overhanging said pivot, as before described, and the shank of said lateral arm, with which it is 90 connected by the rocking pivot, said shank forming a connection between said lateral arm and an engine arm or support. 95

4. The combination, substantially as herein before set forth, with an engine arm or support, of the lateral arm, the rocking pivot of 100 said arm, the driven pulley overhanging said pivot, as before described, the shank of said lateral arm, with which it is connected by the rocking pivot, the flexible power-conveyer, and the hand-piece. 105

5. The combination, substantially as herein before set forth, of an engine-head, a flexible driving-shaft connected therewith, a flexible sheath enveloping said shaft, and a hand-piece casing connected with said engine-head 110 by means of a loose telescopic joint and said flexible sheath, whereby the sheath may have slight end-play relatively to the driving-shaft which it envelops and protects.

6. The combination, substantially as herein before set forth, of the engine-head, the flexible driving-shaft, the enveloping-sheath of 115 said shaft, the tool-holder connected with the outer end of said shaft, and the hand-piece casing, in which said tool-holder has its bearings, connected with said engine-head by means of the loose cylindrical telescopic joint and said sheath, whereby the hand-piece casing may turn upon the tool-holder to conform 120 to the turning movements of the hand of the operator, while the sheath may have slight end-play relatively to the flexible driving-shaft. 125

In testimony whereof I have hereunto subscribed my name.

ELI T. STARR.

Witnesses:

WM. J. PEYTON,

GIBBES M. MAYNADIER.