

1 576 027

- (21) Application No. 18721/77 (22) Filed 4 May 1977 (19)
- (31) Convention Application No. 51/055 127
- (32) Filed 14 May 1976 in
- (33) Japan (JP)
- (44) Complete Specification published 1 Oct. 1980
- (51) INT. CL.³ H01R 13/502
- (52) Index at acceptance
H2E 3A11B 3A1 3A4A 4A4E 3A6C 3E22
- (72) Inventors HIROMASA INOUE, SHINICHI MORITA,
and TAKAO HIROSE



(54) ELECTRICAL CONNECTORS

(71) We, BUNKER RAMO CORPORATION, a Corporation organised and existing under the laws of the State of Delaware, United States of America, of 900 Commerce Drive, Oak Brook, Illinois, United States of America, do hereby declare the invention, for which we pray that a patent may be granted to us, and the method by which it is to be performed, to be particularly described in and by the following statement:—

The present invention relates to electrical connectors.

In the use of multiconductor electrical connectors, it is often desirable to use a housing with a connector to protect the wiring side of the connector and preferably to anchor the electrical cable to the connector so that forces on the cable are not applied to the delicate electrical connections between the conductors and the connector contacts. Additionally, it is often desirable that a portion of the housing surrounds the projecting contacts of a male connector to protect them from damage and possible contact with conductive surfaces which could cause a short circuit. If the male connector is to be surrounded in this manner, it is necessary that a mating female connector should extend beyond its housing so that the female connector can enter the extending portion of the male connector housing to establish electrical connection with the contacts of the male connector. Hithertofore, the difference in mounting depth of the male and female connectors in their respective housings has necessitated the manufacture and use of two dissimilar types of housings, one for use with male connectors and one for use with female connectors.

Additionally, it is often desirable to provide some means for securing mated connectors together to avoid unintentional disconnection. This is most often done by providing one or more latch members on one of the above types of housings and by

providing a similar number of recesses or protrusions on the other type of housing which are engaged by the latching members. 50

Connectors are often mounted on fixed surfaces, and a housing is usually not used in these cases. Therefore, the securing means on the housing used with a connector to be mated with the surface mounted connector are ineffective. 55

According to the present invention there is provided a combination comprising a male electrical connector, a mating female electrical connector and a housing for mounting both the male and female connectors alternatively, the housing comprising first and second sections having matching outlines, each section having an inside and an outside face, the inside face of the first section abutting the inside face of the second section and the sections enclosing at least a portion of either connector when it is in the housing, co-operating means being provided on the housing sections and the connectors to retain the connectors adjacent one end of the housing, the co-operating means including means for retaining the male and the female connectors at respective different locations in the housing, the housing further including latching means attached to at least one of the sections and extending beyond the said one end of the housing, and engagement means attached to at least one of the sections and so disposed that when male and female connectors retained in separate but identical housings are mated, the latching means of one housing engages and latches with the engagement means of the other housing. 60 65 70 75 80 85

A preferred embodiment of a connector housing according to the present invention will now be described with reference to the accompanying drawings in which: 90

Figures 1a and 1b show connector housings of the prior art for use with male and female connectors, respectively;

Figures 2a and 2b show housings of the prior art used with a male and female connector, respectively, which are mated with connectors mounted to a fixed surface;

Figure 3 is a perspective view of the inside faces of the first and second sections of a first embodiment of the connector housing according to the present invention;

Figures 4a, b and c are elevational views of one face and both ends of an assembled housing according to the present invention;

Figure 5 is a front elevational view of two identical housings latched together in a first orientation;

Figure 6 is a front elevational view of two identical housings latched together in a second orientation;

Figure 7 is a side elevational view of two identical housings latched together;

Figure 8 is a perspective view of a preferred embodiment of the surface mounting element;

Figures 9a and 9b are partial elevational views of a housing according to the present invention used with a male and female connector respectively, latched to a surface mounting element used with a mating connector;

Figure 10 is a side view of an alternative embodiment of the engagement means.

Referring to Figures 1a and 1b, the differences between the two types of prior art connector housings 1, 2 can be seen. Housing 1 includes latching members 3 having hooks 4 at the free end thereof for engaging projections 5 on housing 2. Male connector 6 is retained in housing 1 by mounting tabs 7 such that contact portion 8 is completely surrounded by the housing 1. Female connector 9 is similarly retained in housing 2 by mounting tabs 10 so that connector body 11 extends beyond housing 2.

Referring now to Figures 2a and 2b, the problems associated with the use of connector housings according to the prior art with connectors mounted on a fixed surface are readily apparent. When it is desired to connect male connector 6 with surface mounted female connector 9, latching members 3 contact surface 14 and prevent connector 6 from mating with connector 9. When female connector 9 used with housing 2 is connected to surface mounted male connector 6, there are no locking members to engage projections 5 and secure hood 2 to surface 14.

Figure 3 shows the details of the inner face of first section 15 and second section 16 of a preferred embodiment of the connector housing according to the present invention. Each section includes a connector recess 17, 18 and a cable entry passage

19, 20. Additionally, each section contains holes 21, 22 for screws or rivets to fasten the two sections together. Latching tabs 23, 24 extend from one end of each of the sections and include hooks 25, 26 for engaging projections 27, 28 symmetrically disposed on each section. A connector is retained in the sections by either of the pairs of opposing notches 29, 30 or 31, 32.

The housing is formed by installing the wired connector in either of the sections and turning over section 15 in the direction of the arrow 33 to lie on top of section 16.

Figures 4a, b and c show an assembled housing in which like elements are denoted by the same reference number. The alternative positions for male connector 6 and female connector 9 is shown in dotted lines. The mounting tabs 7 of male connector 6 are inserted in opposing notch pair 31. Mounting tabs 10 of female connector 9 are inserted in opposing notch pair 29.

As shown in Figures 5 and 6, the housings A and B can be latched together such that both cables C project in the same direction or in opposite directions.

Referring now to Figure 7, it can be seen that the latching tabs 34 of a first housing A engage projections 35 of a second housing B and the latching tabs 36 of housing B engage the projections 37 of housing A.

If a connector is to be mounted on a fixed surface, a surface mounting element 38 may be used, as shown in Figure 8. The element includes mounting holes 39, connector receiving hole 40, and latching projections 41.

The surface mounting element 38 is shown in use in Figures 9a and 9b. When female connector 9 is to be mounted on fixed surface 14, surface mounting element 38 is placed in between connector 9 and surface 14. Housing A, containing male connector 6, can then be secured to surface 14 by the engagement of latching tabs 34 with projections 41.

Similarly, when male connector 6 is to be mounted on fixed surface 14, surface mounting element 38 can be placed therebetween, allowing housing A, used with female connector 9, to be secured to fixed surface 14.

The latching strength of the housings, or the force required to pull two latched housings apart, is dependent upon the shape of the hooks 25, 26 and the projections 27, 28. If it is desirable that the two housings can be parted with only a small amount of force the projections 27, 28 can be made rounded as shown in Figure 3. However, if it is necessary that the housings remain latched even under strong opposing forces, the projections 42 and hooks

43 can be made with engaging flat surfaces as shown in Figure 10.

Thus far, the only method discussed for retaining the connectors in the housing has been the engagement of the mounting tabs of the connectors in pairs of opposing notches in the housing sections. However, it is to be realized that any known method could be used equally well for retaining the connector in the housing, as it is the essence of the present invention that male and female connectors may be positioned at different locations in the same housing. For instance, male and female connectors could be formed with their mounting tabs at different positions, so that the mounting tabs of all connectors could be inserted in one pair of opposing notches in the housing.

Additionally, only latching members having hooks at their free end for engaging projections have thus far been mentioned. However, it must be realized that any suitable form of latching member could be used which engages either a projection or the wall of a recess in another housing.

Similarly, it is not necessary that each housing section contain recesses and notches. One of the sections could be a simple plate which covers the recess of the other section, with the connector tabs fully received in the notches of one of the sections and prevented from dislodging therefrom by the inner face of the other section.

From the foregoing, it can be readily realized that this invention can assume various embodiments. Thus, it is to be understood that the invention is not limited to the specific embodiments described herein, but is to be limited only by the appended claims.

WHAT WE CLAIM IS:—

1. A combination comprising a male electrical connector, a mating female electrical connector and a housing for mounting both the male and female connectors alternatively, the housing comprising first and second sections having matching outlines, each section having an inside and an outside face, the inside face of the first section abutting the inside face of the second section and the sections enclosing at least a portion of either connector when it is in the housing, co-operating means being provided on the housing sections and the connectors to retain the connectors adjacent one end of the housing, the co-operating means including means for retaining the male and the female connectors at respective different locations in the housing, the housing further including latching

means attached to at least one of the sections and extending beyond the said one end of the housing, and engagement means attached to at least one of the sections and so disposed that when male and female connectors retained in separate but identical housings are mated, the latching means of one housing engages and latches with the engagement means of the other housing.

2. A combination as claimed in Claim 1, wherein said means for retaining is disposed on said sections such that all of the male connector when retained in said housing is enclosed by said housing.

3. A combination as claimed in Claim 1, wherein said means for retaining is disposed on said sections such that a predetermined portion of the female connector retained in said housing is enclosed by said housing.

4. A combination as claimed in Claim 1, wherein said means for retaining includes at least one pair of opposed notches in at least one of said sections for receiving mounting tabs of the connector.

5. A combination as claimed in Claim 4, wherein said means for retaining includes a first pair of opposed notches for retaining the male connector and a second pair of opposed notches for retaining the female connector.

6. A combination as claimed in Claim 1, wherein said latching means includes at least one finger-like tab extending from one side of at least one of said sections and having an engaging hook at the free end thereof.

7. A combination as claimed in Claim 6, wherein the engagement includes at least one projection protruding from one side of at least one of said sections.

8. A combination as claimed in Claim 7, wherein two finger-like tabs and two projections are symmetrically arranged on said housing.

9. A combination as claimed in Claim 1, in combination with a surface mounting element comprising: means for attaching said element to a fixed surface adjacent a connector; and engagement means disposed to be engaged by the latching means of said housing.

10. A combination as claimed in Claim 4, wherein the section abutting said at least one section including said notches, is a flat plate.

11. A combination as claimed in Claim 4, wherein both said sections include at least one pair of opposed notches.

12. A combination comprising a male electrical connector, a female electrical

65
70
75
80
85
90
95
100
105
110
115
120

connector and a housing substantially as hereinbefore described with reference to Figs. 3 to 10 of the accompanying drawings.

REDDIE & GROSE,
Agents for the Applicants,
16 Theobalds Road,
London WC1X 8PL.

Printed for Her Majesty's Stationery Office by Burgess & Son (Abingdon), Ltd.—1980.
Published at The Patent Office, 25 Southampton Buildings, London, WC2A 1AY,
from which copies may be obtained.

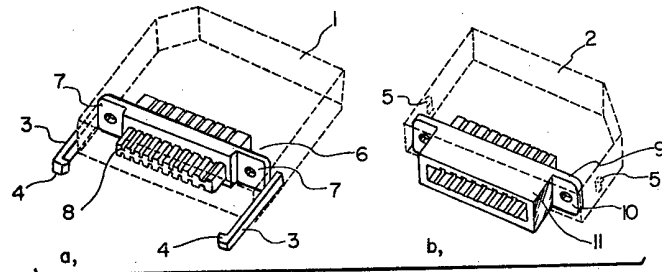

FIG. 1.

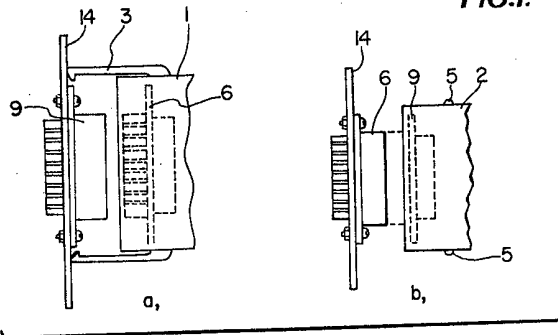

FIG. 2.

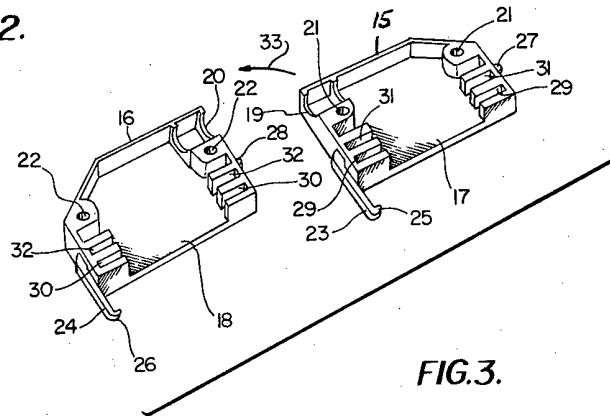

FIG. 3.

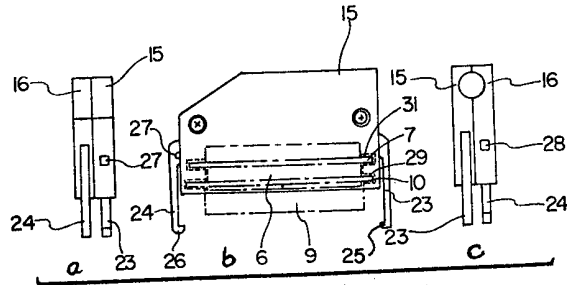

FIG. 4.

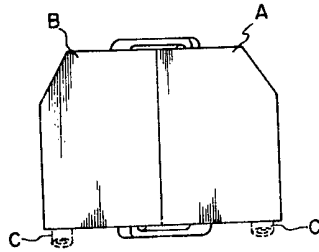

FIG. 5.

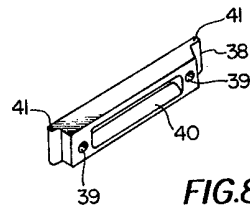

FIG. 8.

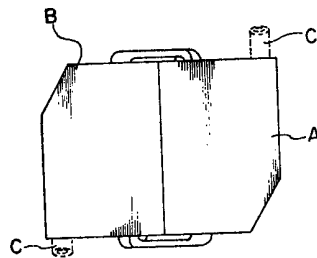

FIG. 6.

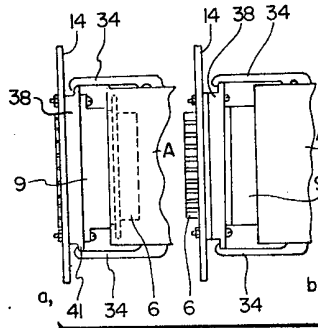

FIG. 9.

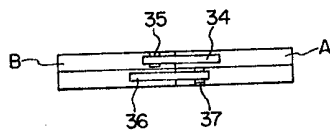

FIG. 7.

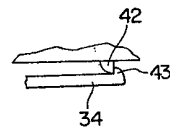

FIG. 10.