

P. F. RERDON.
HYDROCARBON GAS BLACK MACHINE.

No. 523,945.

Patented July 31, 1894.

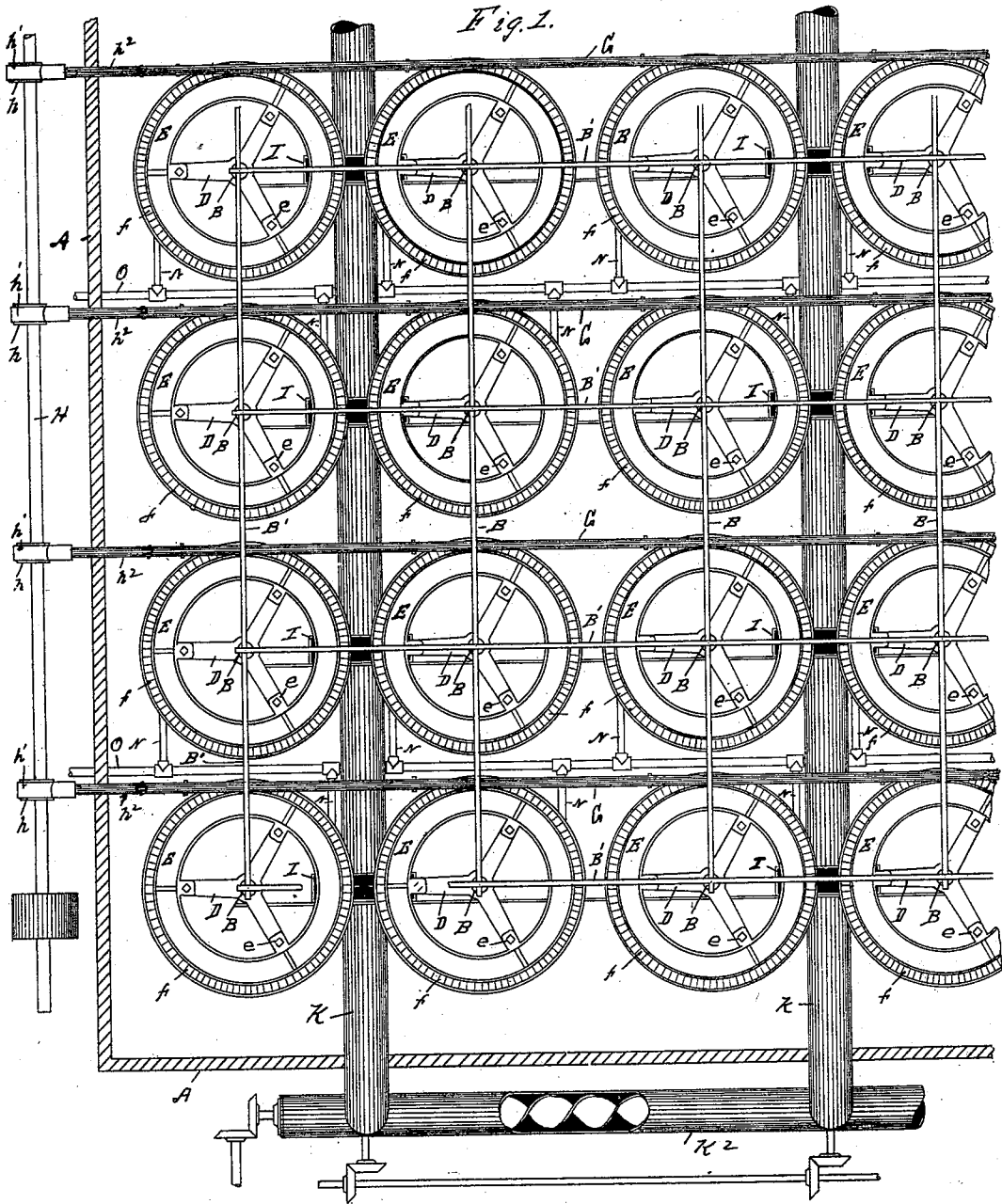

WITNESSES.

F. J. Barrett

A. L. Jackson

INVENTORS.

Patrick F. Rerdon

By J. B. Sturgeon
Att'y.

P. F. RERDON.
HYDROCARBON GAS BLACK MACHINE.

No. 523,945.

Patented July 31, 1894.

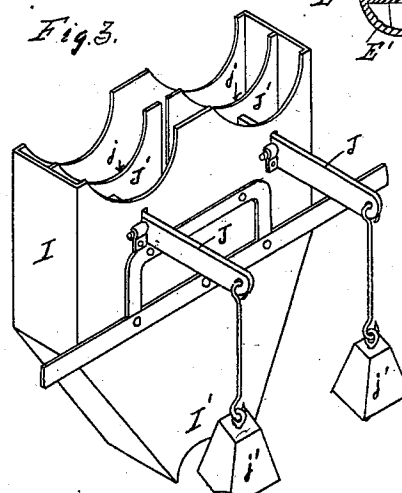
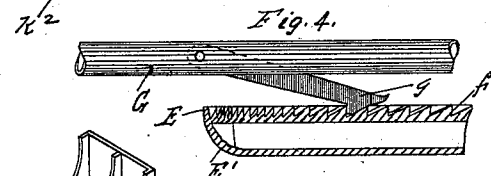
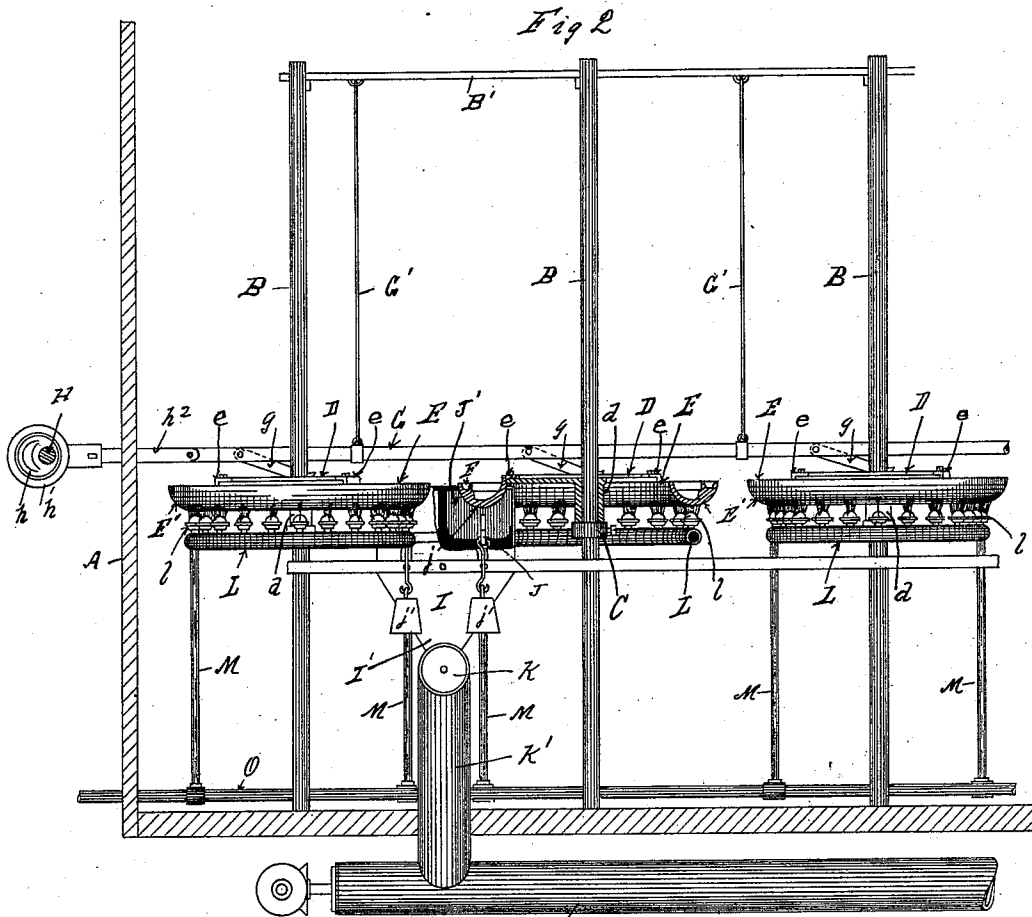

WITNESSES.
F. J. Barntt
A. L. Jackson

INVENTORS.
Patrick F. Rerdon
 By *J. H. Sturgeon*
Atty.

UNITED STATES PATENT OFFICE.

PATRICK F. RERDON, OF KANE, PENNSYLVANIA, ASSIGNOR OF ONE-HALF
TO JAMES McDADE, OF SAME PLACE.

HYDROCARBON-GAS-BLACK MACHINE.

SPECIFICATION forming part of Letters Patent No. 523,945, dated July 31, 1894.

Application filed March 3, 1894. Serial No. 502,255. (No model.)

To all whom it may concern:

Be it known that I, PATRICK F. RERDON, a citizen of the United States, residing at Kane, in the county of McKean and State of Pennsylvania, have invented certain new and useful Improvements in Hydrocarbon-Gas-Black Machines; and I do hereby declare the following to be a full, clear, and exact description of the invention, such as will enable others skilled in the art to which it appertains to make and use the same, reference being had to the accompanying drawings, and to the letters of reference marked thereon, forming part of this specification.

My invention consists in the improvements in hydro-carbon gas black machines, hereinafter set forth and explained and illustrated in the accompanying drawings, in which—

Figure 1. is a top or plan view of a section of my improved hydro-carbon gas black machine. Fig. 2. shows a side view of a section of my improved hydro-carbon gas black machine, partially in elevation and partially in section. Fig. 3. shows a perspective view of the receiving box and scraper mechanism for collecting the black. Fig. 4. shows a detail view of a section of one of the rings of my device and the actuating mechanism thereof.

The principal features of my invention relate to the form of the deposit rings of my device, and to the driving mechanism of the rings.

Heretofore, hydro-carbon gas black machines have usually been constructed either of flat plates of greater or less width, against the under surfaces of which the flame of the jets of burning gas impinge, and upon which plates scrapers operate to remove the black as it accumulates, or of rotating cylinders which rotate over jets of burning gas, and from which the black is also removed by means of scrapers. In both of these types of machines there are serious defects, in the first type, that constructed with flat plates, the black is burned unequally, so that it is defective in quality, while in the second type, constructed with rotating cylinders, the quality of black produced is better, there are almost insuperable difficulties experienced in its construction and operation. In my construction I overcome all these difficulties, and

am enabled to construct and operate my machine without difficulty and at the same time utilize a semi-cylindrical surface upon which to deposit the black, and thus insure the best possible results in the quality of black produced.

In the construction of my improved hydro-carbon gas black machine, illustrated in the accompanying drawings, A, A, are two of the walls of the building, which walls, together with the top, (not shown) of the building are usually made of sheet iron; within this building are placed iron posts B at a uniform distance from each other, both ways, and secured together at the tops thereof by means of transverse bars B'. Upon these posts B are secured collars C, upon which rest the hubs *d* of spiders D; these hubs *d* being so fitted around the posts B as to rotate freely around the same upon the collars C.

To the ends of the arms of the spiders D are secured horizontal deposit rings E by means of bolts passing through the ends of the arms of the spiders into lugs or ears *e* on the inner edges of the rings E. These deposit rings E I construct with their undersurfaces E' semi-cylindrical in shape, the cross sections of which preferably have a radius of, say, three and one-half inches, which semi-circular surfaces are exposed to jets of burning gas as hereinafter described. On the tops of the outer edges of these deposit rings E are annular grooves F, in the bottoms of which are annular racks of ratchet teeth *f*, as seen in Figs. 1 and 4, as and for the purpose hereinafter set forth.

Along one edge of and a short distance above the tops of the rings E, directly over the grooves F therein, are horizontal rods or bars G suspended by rods G' from the bars B', so that the rods G will move freely with a reciprocal motion endwise, and to the rods or bars G are pivoted dogs *g*, the ends of which travel with a reciprocal movement, imparted thereto by the movement of the rods or bars G, in the grooves F in the tops of the rings E, and engage the ratchet teeth *f* in the bottoms of said grooves, when moved in one direction, so as to rotate the rings E, but pass over the teeth *f* freely when moved in the opposite direction. At one end of and out-

side of the building opposite the ends of the rods or bars G, is a shaft H having an eccentric *h* secured thereto opposite the end of each of the rods or bars G, around which eccentrics *h* are eccentric straps *h'* from which connecting rods *h²* extend to and are pivoted to the ends of the rods or bars G, so that the rotation of the shaft H operates to move all of the rods or bars G, and the dogs *g* on said rods or bars with a reciprocal movement, which operates to turn the rings E.

Under the adjacent edges of each pair of the rings E is secured a box or receptacle I (Fig. 3.), in the side of which box are pivoted levers J, which are provided, on the ends thereof, within the box, with scrapers J', the upper ends of which are provided with semi-circular recesses *j*, adapted to fit up against the under surfaces of the rings E; the outer ends of the levers J are provided with weights *j'* which operate to retain the scrapers J' in close contact with the under surfaces E' of the rings E as they are being rotated by means of the mechanism hereinbefore described, and scrape the black accumulated thereon off, when it falls into the boxes I; the lower ends I' of these boxes I are hopper shaped, and connect with longitudinal screw conveyers K, which discharge the black through a pipe K' into another screw conveyer K² outside of the building.

Under each of the deposit rings E is a circular pipe L which extends around under the center of the semi-circular under surface E' of the rings to the boxes I where the ends thereof are closed, and in the upper surface of the pipe L are inserted small burners *l*, from each of which a jet of flame from the burning gas impinges against the curved under surface E' of the rings E, the heat and unconsumed products of combustion passing up at each side of the ring E in close contact with the curved under surface thereof, and depositing the black thereon, from whence it is removed by the scrapers J during the rotation of the rings E, as hereinbefore described. These curved pipes L are supplied with gas

by means of upright pipes M which connect with lateral branches N from mains O, through which gas is supplied thereto.

The operation of this invention is so obvious from the description heretofore given thereof, that further reference thereto is deemed unnecessary. Therefore,

What I claim as new, and desire to secure by Letters Patent of the United States, is—

1. The combination in a deposit-ring for hydro-carbon gas black machines, of a semi-circular under face, and an annular groove around the periphery of the top thereof, and ratchet teeth in the bottom of said groove, substantially as and for the purpose set forth.

2. The combination in a hydro-carbon gas black machine, of a series of upright posts, deposit rings having semi-circular under surfaces, mounted and adapted to rotate upon said posts, reciprocating bars or rods carrying dogs adapted to engage ratchet teeth on the upper surfaces of said rings, and shaft and eccentric mechanism thereon communicating with and actuating said reciprocating bars or rods, substantially as and for the purpose set forth.

3. The combination in a hydro-carbon gas black machine, of horizontally rotating deposit rings E, having semi-circular under surfaces E', and annular grooves F having ratchet teeth *f* in the bottom thereof on the upper surfaces of said rings, a shaft H having eccentric mechanism *h*, and *h'* thereon, operating reciprocating rods or bars G, dogs *g* on said rods or bars G engaging the ratchet teeth *f* on said deposit rings, an annular row of gas jets under each of said deposit rings, scrapers J' and boxes I for removing and receiving the black from said rings, and screw conveyers connecting with said boxes, substantially as and for the purpose set forth.

In testimony whereof I affix my signature in presence of two witnesses.

PATRICK F. RERDON.

Witnesses:

H. W. SWEELY,
JNO. OLIVER.