

Oct. 10, 1967

C. E. VALENTE

3,345,933

COIN OPERATED AUTOMATIC VENDING MACHINE, TO BREW AND
DISTRIBUTE HOT COFFEE IN CUPS

Filed April 8, 1964

7 Sheets-Sheet 1

FIG. 3

FIG. 1

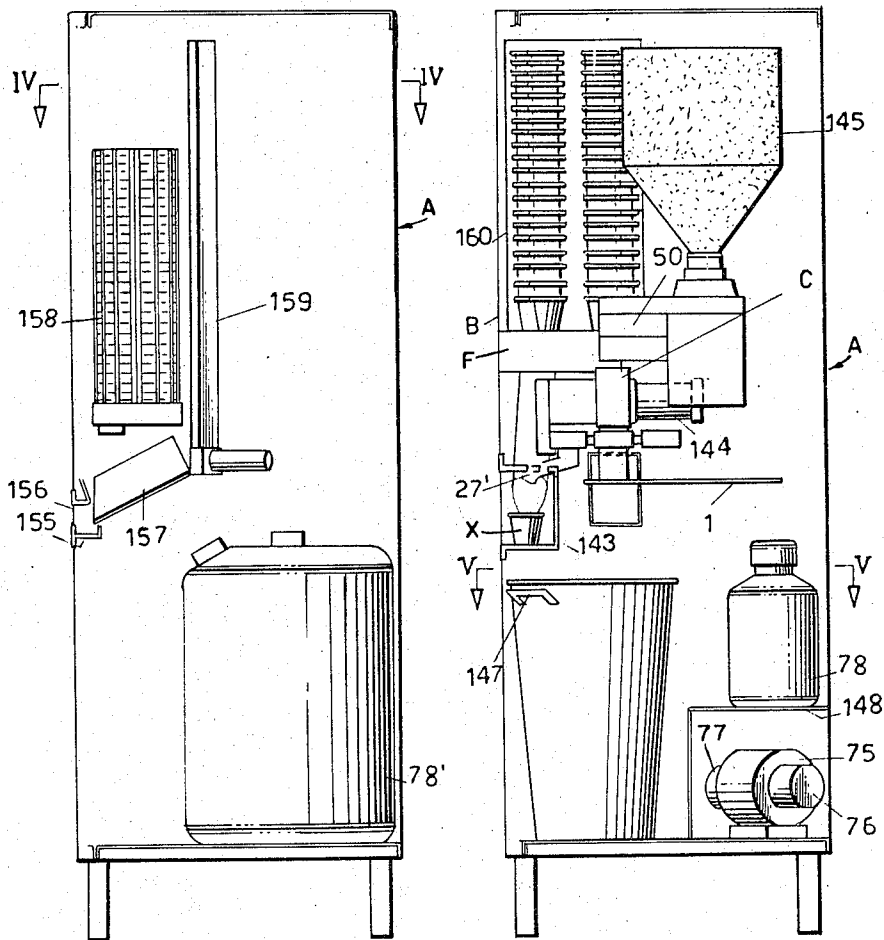

INVENTOR:
CARLO ERNESTO VALENTE
By Silverman + Cass
ATT'YS.

Oct. 10, 1967

C. E. VALENTE

3,345,933

COIN OPERATED AUTOMATIC VENDING MACHINE, TO BREW AND
DISTRIBUTE HOT COFFEE IN CUPS

Filed April 8, 1964

7 Sheets-Sheet 2

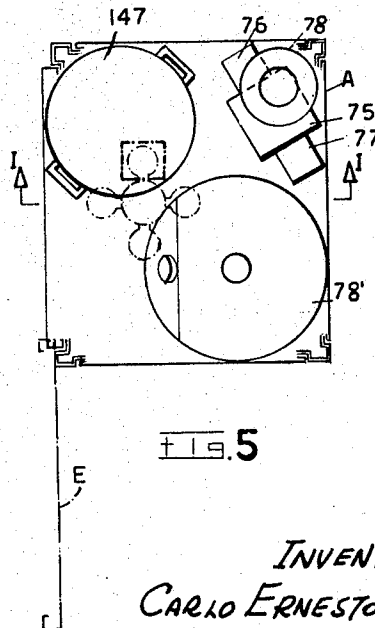
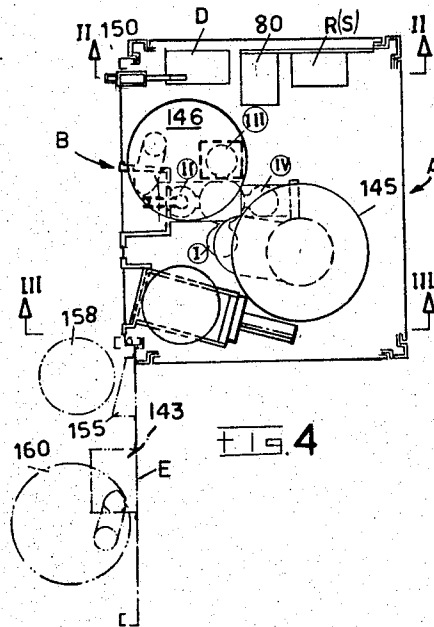
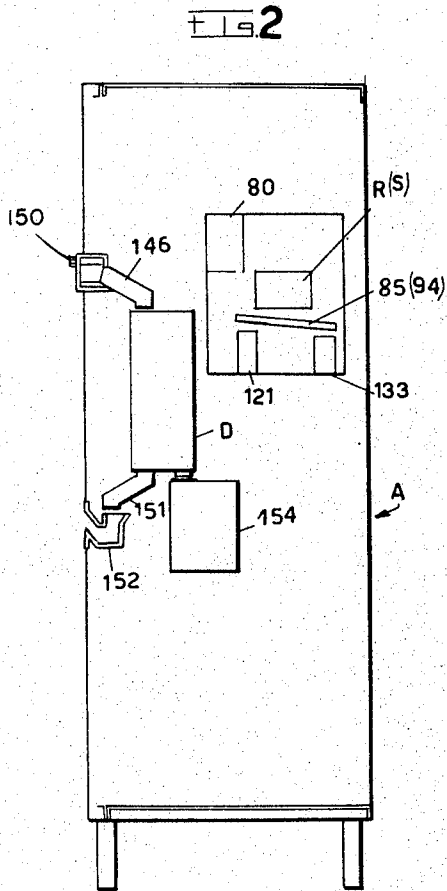

INVENTOR:
CARLO ERNESTO VALENTE
By Silverman & Cass
Attys.

Oct. 10, 1967

C. E. VALENTE

3,345,933

COIN OPERATED AUTOMATIC VENDING MACHINE, TO BREW AND
DISTRIBUTE HOT COFFEE IN CUPS

Filed April 8, 1964

7 Sheets-Sheet 3

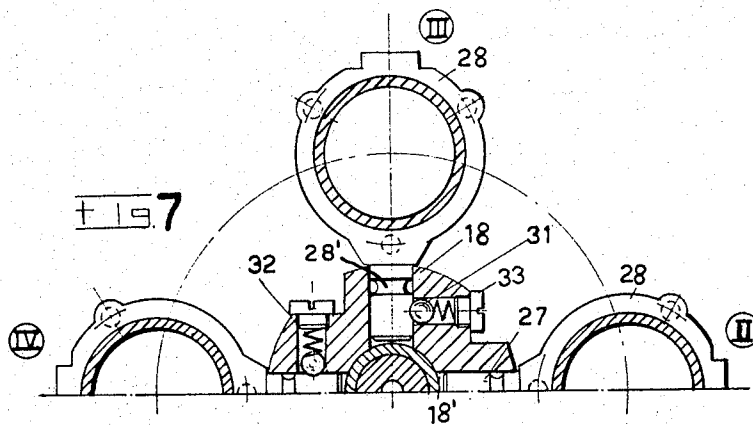
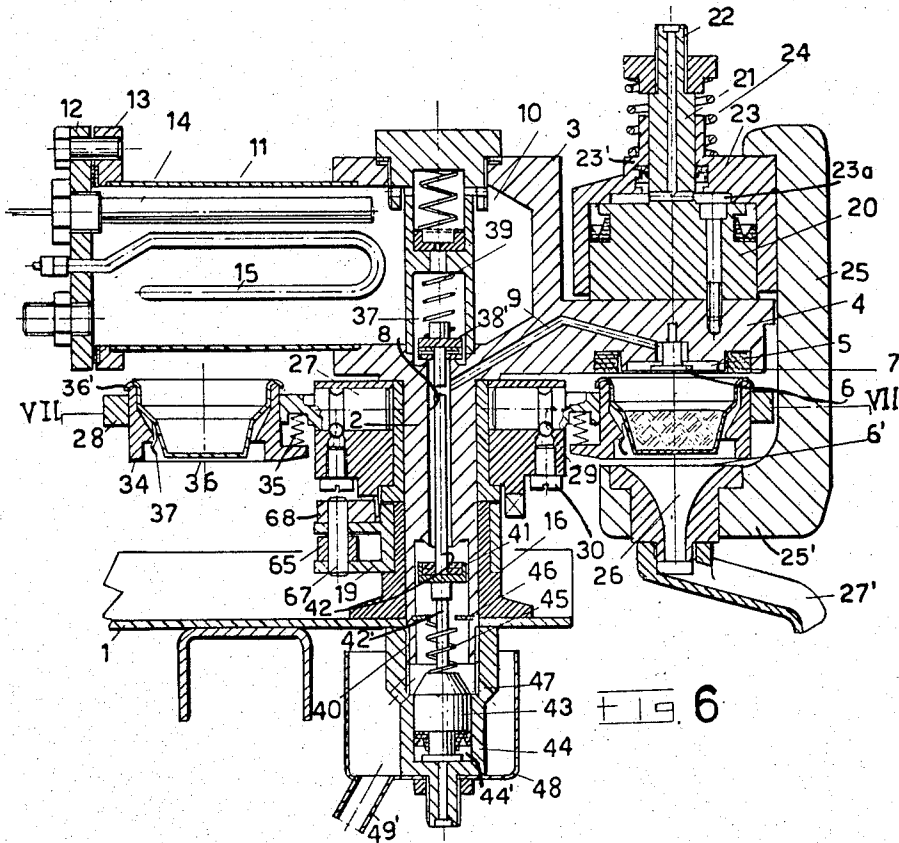

INVENTOR:
CARLO ERNESTO VALENTE
By *Silberman & Coas*
ATT'YS.

Oct. 10, 1967

C. E. VALENTE

3,345,933

COIN OPERATED AUTOMATIC VENDING MACHINE, TO BREW AND
DISTRIBUTE HOT COFFEE IN CUPS

Filed April 8, 1964

7 Sheets-Sheet 4

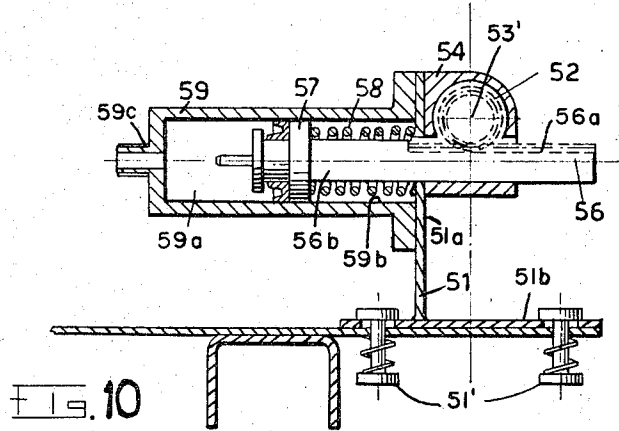
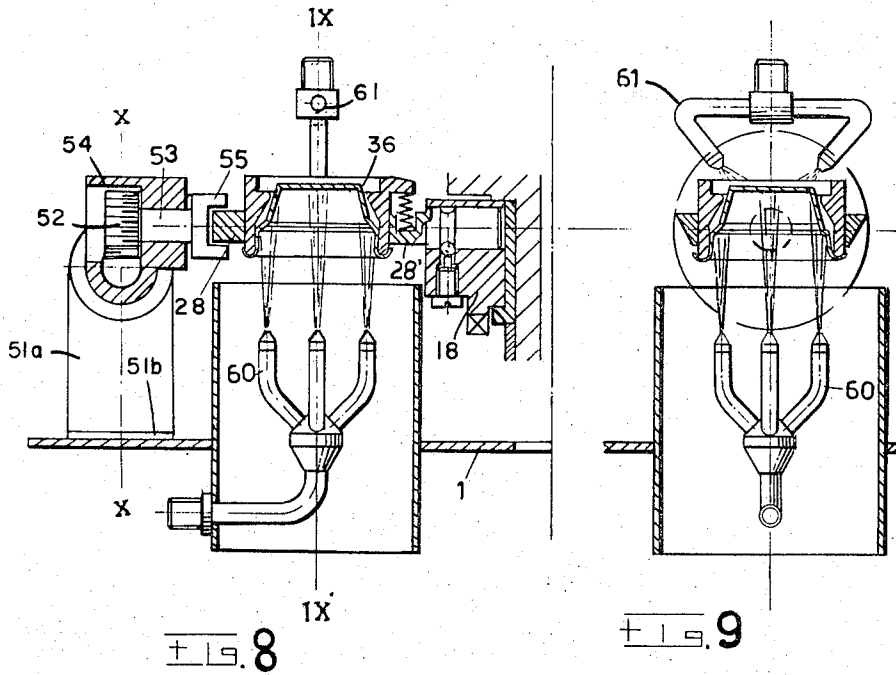

INVENTOR:
CARLO ERNESTO VALENTE
By *Silverman & Cass*
ATT'YS.

Oct. 10, 1967

C. E. VALENTE
COIN OPERATED AUTOMATIC VENDING MACHINE, TO BREW AND
DISTRIBUTE HOT COFFEE IN CUPS

3,345,933

Filed April 8, 1964

7 Sheets-Sheet 5

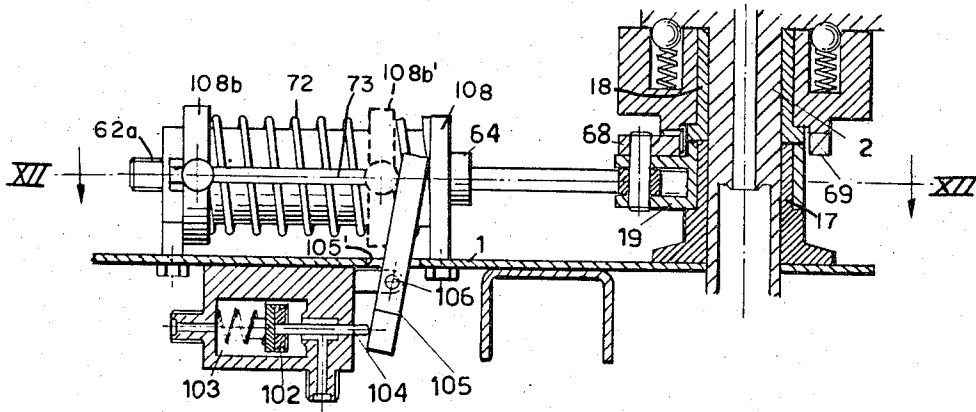

FIG. 11

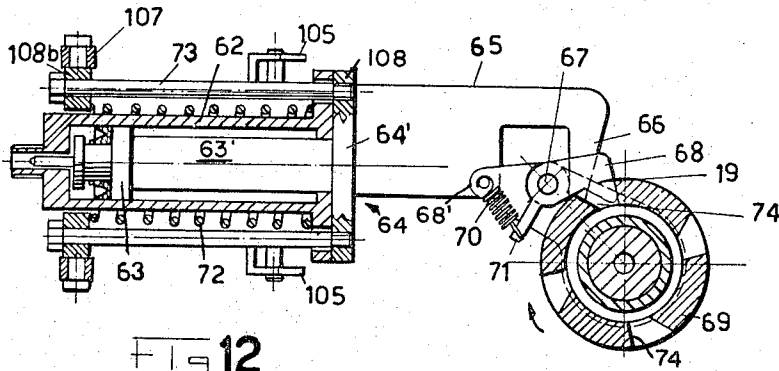

FIG. 12

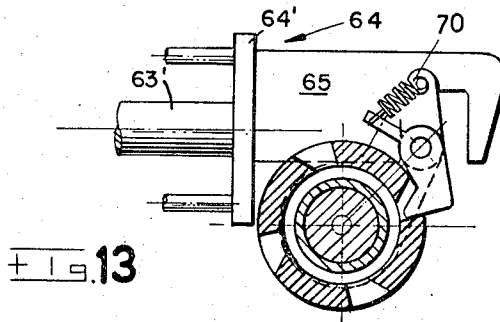

FIG. 13

INVENTOR:
CARLO ERNESTO VALENTE
By *Silverman & Cross*
ATT'YS.

Oct. 10, 1967

C. E. VALENTE
COIN OPERATED AUTOMATIC VENDING MACHINE, TO BREW AND
DISTRIBUTE HOT COFFEE IN CUPS

3,345,933

Filed April 8, 1964

7 Sheets-Sheet 7

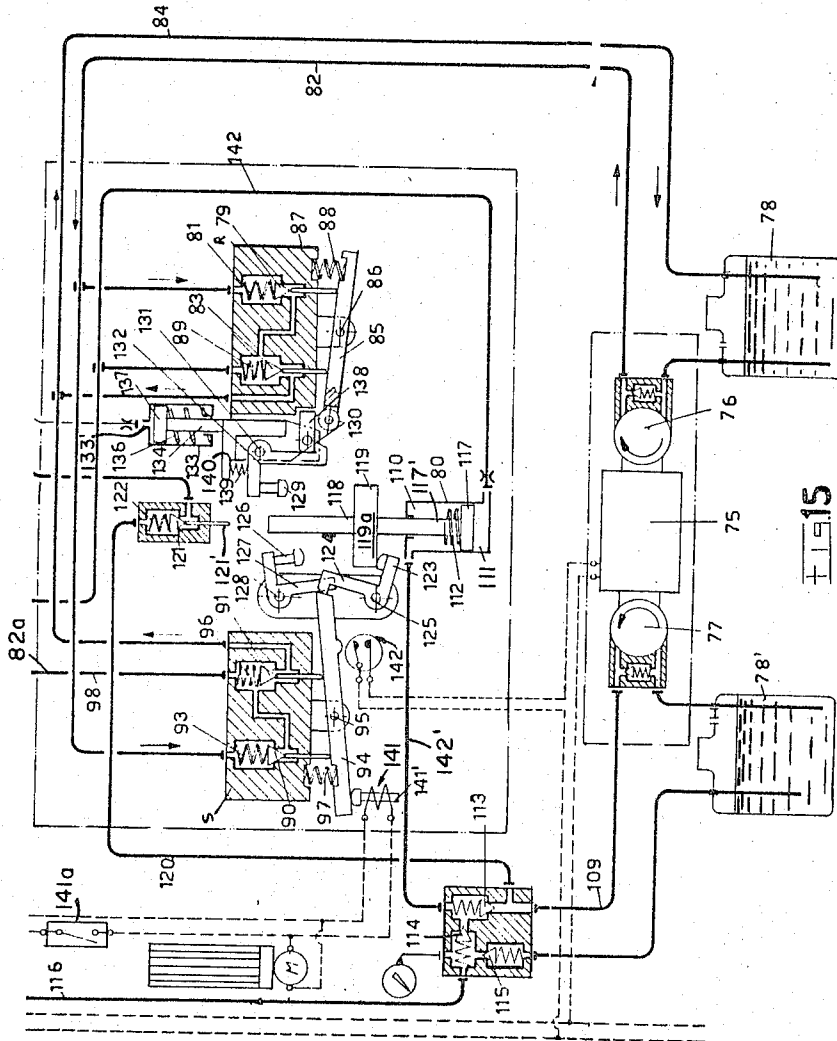

INVENTOR:
CARLO ERNESTO VALENTE
By Silverman + Coos
Att'ys

1

3,345,933

COIN OPERATED AUTOMATIC VENDING MACHINE, TO BREW AND DISTRIBUTE HOT COFFEE IN CUPS

Carlo Ernesto Valente, Via G. Ventura 5, Milan, Italy

Filed Apr. 8, 1964, Ser. No. 358,169

Claims priority, application Italy, Dec. 4, 1963,

33,938/63

13 Claims. (Cl. 99—283)

This invention concerns coin operated vending machines, particularly for the vending of coffee.

The object of the present invention is to provide a reliable automatic machine adapted particularly to the preparation and vending of hot coffee.

There are many machines which have been developed and tested for the above purpose but hitherto it was not possible to guarantee consistent operation and the production of consistently good coffee.

A further object of the invention, therefore, is to provide a machine which will fulfill the rigid demands for safety, accuracy of operation and endurance.

According to the present invention a coin operated vending machine for dispensing hot coffee is characterized in that there is provided an intermittently rotatable carrier upon which may be located, at spaced intervals, a plurality of strainers adapted to receive in succession a predetermined amount of ground coffee, there being means for moving said carrier in accordance with an operating cycle to present successive strainers in position to receive said ground coffee, to become positioned above a coffee receiving cup, and to be inverted for the purpose of removing used coffee and making the strainers ready for re-use.

Preferably the vending machine includes a box-like housing for the dispensing apparatus, a shelf located at about mid-height upon which is assembled a composite item for the brewing of coffee drinks at one side of said composite item, a coin receiving item fixed on said shelf to which the coin arrives through a slot formed on the front face of housing, a door at the front of the housing, a device to distribute spatula stirrers one at a time via a slide accessible through an opening in the face of the housing, electric motor drive for pump means, a tank for purified water and a separate tank for water emulsified with silicones, a container to receive used coffee powder, a device to distribute sugar lumps, a distributor for the cups made from waterproof material, an aperture through which coffee cups may be removed from the housing, said aperture being located below a slanting trough from which coffee is poured into the cup, a composite device in the form of a rotatable hub intermittently movable in a determined direction by a hooked two arm lever adapted to be moved by a further lever regulated by a pressure piston having a reciprocating travel, each movement of the hub being through 90°, to enable a strainer to be located at a predetermined position, strainer holders at the extremity of arms formed on the hub, an electro grinder above one strainer station, a distributing spray for coffee brewing water connected with a hot water tank by means of a normally closed valve located at a further strainer station, strainer flushing nozzles to flush the strainers after each use thereof, an assembly including a hydraulic circuit regulated by a first pump actuated by said electric motor for the control of

2

all of the hydraulic servomotor cylinders needed and coordinated by the different functions of device, a further hydraulic circuit adapted to receive drinking water, and controlled by a second pump also actuated by said electric motor, said second pump being arranged to furnish water at a given pressure to a receiving tank adapted to receive and heat water for the brewing of coffee, and to provide water for the flushing out of strainers after each use thereof through a duct and valve (usually shut), a first valve group inserted in a closed circuit of the first pump, a lever stressed by return spring action adapted normally to maintain said valves in discharge position in said hydraulic cylinders, hook means associated with said lever and adapted, with said return force or pressure, at the position of the closing of an electric switch in an electric circuit of said motor and with valves set in working position for said cylinders of hydraulic servomotors and a group of valves also inserted in said closed circuit for the water for the servomotors, a lever under the stress of a return spring adapted normally to maintain a further valve shut on the outflow stage period and opens the one on the inflow, a hook device adapted to contact a further lever biased to position the inflow valve shut and the outflow valve open, a hydraulic cylinder in which slides a piston of which cylinder one chamber is connected with the outflow of a second pump by means of a second group of valves where piston and cylinder are in combination with the piston of a further cylinder adapted to retain a strainer in position below a spray device, the piston rod of the last mentioned piston extending beyond the cylinder to contact a lever adapted to control a second group of valves when a pressure is present in the servomotor cylinder to hold the strainer in a leakproof manner below said spray, a piston rod of said first cylinder projecting from said cylinder to cooperate successively with one engagement for the opening of the valve for the flushing of strainer at one of said stations and for the releasing of a lever adapted to release said first group of valves and for engagement with means for the releasing of the lever adapted to control the second group of valves.

One practical embodiment of such a machine is hereafter described by way of example, with reference to the accompanying drawings, wherein:

FIG. 1 is a part sectional front elevational view of a machine taken along the line I—I of FIG. 5.

FIG. 2 is a part sectional side elevational view of the machine taken along the line II—II of FIG. 4.

FIG. 3 is a part sectional side elevational view of the machine taken along the line III—III on FIG. 4.

FIG. 4 is a part sectional plan view of the machine taken along the line IV—IV of FIG. 3, dot and dash lines illustrating a door in an open position.

FIG. 5 is a part sectional plan view taken along the line V—V of FIG. 1.

FIG. 6 is a detail sectional view of a central device for the machine.

FIG. 7 is a sectional plan view of part of the mechanism of FIG. 6 taken along the line VII—VII.

FIG. 8 is a detail section of part of the mechanism of the machine.

FIG. 9 is a vertical sectional view of FIG. 8 taken along the line IX—IX.

FIG. 10 is a vertical sectional view taken along the line X—X of FIG. 8.

FIG. 11 is a detail sectional view of part of the machine.

FIG. 12 is a sectional plan view of FIG. 11 along line XII—XII and in the direction indicated.

FIG. 13 is an enlarged detail of FIG. 12 showing the parts thereof in an alternative position.

FIG. 14 is a schematic illustration showing general arrangement of the working elements of the mechanism according to the invention, the parts thereof not being illustrated in exact positional relationship for the sake of clarity.

FIG. 15 is another schematic illustration of the general arrangement of the working mechanism, specific upon the hydraulic circuit for the machine and is complementary to the illustration of FIG. 14.

Referring to the drawings, A indicates generally a housing for the mechanism. The housing A is a box-like, upright structure having a rectangular base provided with four legs. B denotes generally the front of the machine, which includes a door E hinged on one vertical side. The open position of the door is indicated by the dot and dash line on FIG. 4. Within the housing A approximately midway between the base and the top is provided a horizontally positioned shelf-like steel plate 1, which extends over part only of the area of the housing A to leave a space in the frontal region whereby when the door B is closed a box-like member 143, internally fixed to the door B does not foul the shelf 1.

Mounted on the shelf 1, on an axis located vertically in the center of the housing when the later is viewed from the front but displaced forwardly of the center, when viewed from the side is the axis of a rotatable spider 144 upon which are mounted four strainers. A device C hereinafter described in detail is also fixed to shelf 1. The strainers are adapted to be located successively at one of four stations. Station I is located at the right of the housing (when viewing the machine from in front), station II is located in front of the machine, station III to the left and station IV at the rear. Located above strainer station I is an aperture from which the "doser" is connected to an electro-grinder 50, from which ground coffee is fed. The grinder receives coffee grains from a receptacle 145 located above it. Below the strainers at station III is located a handled receptacle 147 which is disposed at the inside bottom corner of the housing and serves to collect used coffee grounds.

The receptacle 147 occupies the bottom left hand corner of the housing (when viewed from the front). Below the shelf 1 at the right hand bottom corner of the housing is located a tank 78' from which purified water hereinafter referred to as second fluid, is supplied to brew the coffee.

At the bottom left hand corner of the housing is located a pumping mechanism composed of an electric motor 75 located centrally between two pumps. The motor is movable as desired to operate respectively pump 76 (for the delivery in a closed circuit coordinated to the servo-motors which regulate the actuations proper of the various items of the machine) and also pump 77 which supplies the proper pressure to the water used for the brewing of coffee and also for the flushing out of used strainers.

The pump assembly is shielded by cover 148. The cover 148 carries a tank 78 adapted to contain siliconized water hereinafter referred to as first fluid which, during operation of the machine is used by pump 76, in a manner yet to be explained.

FIGS. 2, 4 and 5 illustrate a coin receiving device which serves to actuate the controlling mechanisms which are located on the upper left hand internal side wall of housing A. The fixture (see FIG. 2) generally indicated by the reference D (which fixture is well known to those in the art), includes a trough 146 (where the coin is inserted) opening into a slot 150 which latter is positioned

vertically on door B and a second trough 151, for the collection and/or rejection of coins opens above a cup-like basin 152 easily accessible from the outside of the door B by the way of opening 153 through the door. The opening 153 is located perpendicularly below the entry slot 150. Below the fixture D is a collecting box 154.

On the internal face of the door B approximately midway between the top and the base, and to the right of the door is located another receptacle 155, also accessible from outside the door B. The receptacle 155 is formed at the extremity of a slide 157 which latter is fixed to the door B. Above the trough and on the internal face of the door is arranged a distributing device 158 for lumps of sugar. The housing is provided with a distributor for "spatulas" which may be used to stir the sweetened coffee. The distributor for the spatulas is generally indicated by the reference 159. The stirrers are fed to the slide 157 as well.

Also attached to the door is a container 160 which holds a supply of disposable coffee cups which are fed as required to a receiving box 143. On each operation of the machine a single coffee cup, X, is fed to the box 143 by means F, well known in the art, and becomes located below a discharge spout 27' of device C, which latter is the appliance used for the brewing of coffee. The device C is immediately hereafter described in detail.

Referring to FIG. 6, the shelf 1 has secured thereto, by means of shaft 2, a member 3 from which extends a radially disposed arm 4. The arm 4 is provided on its lower face with a cylindrical cavity 5 in which is inserted a liquid spray dispenser 6, surrounded by a waterproof gasket 7. The gasket 7 is fitted in a recess of the body of the arm itself and the cavity 5 is connected to a bore 8 of stem 2 by way of a bore 9 in the arm 4.

Member 3 also is provided with an upper cavity 10 adjacent its upper end.

The cavity 10 is diametrically opposite to an arm at station IV. A housing 11 is connected in a leakproof manner to member 3 and the outer end of housing 11 is provided with a flanged cover 12, which latter is bolted to a flange 13 formed integral with the housing 11.

Within the housing 11 is located an electrical resistance 14 and a thermostat 15. Thus the enclosed cavity 10 forms a tank for heating brewing water.

The stem 2 is held on the shelf 1 by means of a sleeve 16, which is integral with the stem 2. The sleeve is provided with a flange to facilitate its fastening to shelf 1. The upper end of the stem 2 is encased in a sleeve 17 (made integral with it) on which is rotatably mounted (yet not axially loose) a hub 18 of spider 144. Sleeve 16 is attached to a crank 19 by means of a knuckle joint. A lever linkage (see FIGS. 11 and 12) is connected by means of spikes to a ratchet gear 69 on hub 18, for a purpose that will be explained later.

Above arm 4, and coaxial with cavity 5, is located a spray 6, which is mounted on a piston 20. The upper end of the piston 20 is provided with a stem 21 which in turn has an extension 22 on its upper end. The extension 22 is of smaller diameter than the stem 21 and is externally threaded.

The stem 21 is fitted with a member 23. The member 23 is provided with a seat 23' at its upper end. Between this seat and a nut screwed on the threaded extension 22 is located a spring 24 adapted to exert downward pressure on the member 23 and thus upon the piston 20 (as is plainly shown in FIG. 6).

Stem 21 and its extension 22 are bored so as to allow (for the purposes hereafter explained) pressurized fluid to flow in the chamber of cylinder 23 formed on the upper side of piston 20. In use the pressure of the fluid is sufficient to overcome the spring and thus raise the cylinder 23. The cylinder 23 is provided with an outwardly extending rib 25 which extends below and beyond the cylinder wall and is formed to extend toward the cylinder axis to form an extension 25' having a surface 6' located opposite

to spray 6. The said return-bent extension 25' is provided with a funnel shaped cavity 26 the lower end of which is provided with a discharge spout 27'. The hub 18 of the spider 144 is provided with 4 radial holes 18' spaced at 90° from each other. Each hole 18' is adapted to receive the pin 27 of a collar 28. The pins each have a peripheral groove 28' of a semi-circular cross-section into which a small retaining ball 29 can enter. The balls 29 are each kept in place by a screw 30 radially located in the pin and being screwed in the underside of the hub 18. The hub is also provided with balls 31 which are held in abutment with their respective pins 27 by the action of a spring 32 retained by a screw 33 which latter is also screwed in the hub radially to the pin 27.

The collar 28 being engaged and actuated by the devices hereafter described, will assume four working positions which can be seen from FIG. 7. The four positions are strainer in readiness position marked IV, strainer in loading position marked I, strainer in brewing position marked II, exhaust of coffee grains and flushing of strainer position marked III.

Located within an aperture of collar 28 there is provided a strainer holder 34 adapted to receive a strainer 36, designed to be a loose fit within the holder and to be held in place by spring 37 (of which only one is shown). The springs 37 are attached by one of their ends to the collar and at the other end to a small flange provided on the strainer holder.

The strainer 36 is inserted loose in its holder 34 and is caused to overcome the reaction of the spring by the application of slight pressure to cause it to rest against the upper rim of strainer holder. The upper end of the strainer is provided with an outwardly turned rim 36'.

The height between the rim 36' and the lower edge of the filter holder is less than the height between the liquid spray dispenser 6 and the surface 6' of the extension 25' of the rib 25 of cylinder 23. The cylinder 23 and the strainer 36 are arranged so that the strainer is coaxial, in position II, with cylinder 23 and cavity 5.

Hole 8 of stem 2 communicates at its upper end with upper cavity 10 through a valve 38 whose disc 38' is axially free in the cylindrical chamber 37 of valve 38, said chamber forming a larger diameter axial extension of the bore 8 of stem 2.

The valve disc 38 is kept normally in a closed fluid tight position against the end of the hole 8 by a spring 39.

The hole 8 communicates at its lower end with a cylindrical cavity which forms a chamber 40. The stem 2 is provided with an extension which is housed in the cavity 40.

Within the cavity 40 is freely slidable the valve disc 41, the upper end of which is fitted with a stem 42 of lesser diameter than hole 8 and is freely slidable therein. The lower face of the valve disc 41 is fitted with a valve stem 42', which is integral with a piston 43 slidably received in a cylinder 44. The cylinder 44 is attached in a fluid tight manner to the bottom end of stem 2.

The piston 43 is normally retained in its lower position by the force of a spring 45, which is located between the piston and a washer 46. Washer 46 is provided with a central hole for the insertion of stem 42. Washer 46 is attached to stem 2 as shown in FIG. 6.

The cylinder chamber 44', located below the piston 43 on the opposite side thereof to that where the spring 45 is located, is connected to a high pressure pipe, in a manner which will be made clear hereafter.

The upper stem 42 of valve 41 is of such length that when the valve 41 is fully opened the upper end of stem 42 is spaced a predetermined distance from valve disc 38, while, when the valve 41 is in its closed position, the upper end of stem 42 abuts the valve disc of valve 38 thereby raising it up from its seat and so opening said valve 38 to connect cavity 10 with cavity 5.

The lower end portion chamber 40 (defined by the

lower end of stem 2 and the upper end of cylinder 44, and, in particular between washer 46 and the upper end of piston 43) is provided with a peripheral hole 47, which connects said chamber portion with the outside, a cylindrical tray 48 is located around it and this latter is provided with a discharge spout 49 as shown in FIG. 6.

Mounted on shelf 1, in a manner well known to those skilled in this art, is located an electro grinder mill 50 above which is located a container 145 adapted to receive unground coffee.

To one side and below the container adapted to hold a quantity of ground coffee not shown in the drawings and only partially included with reference 50 in FIG. 14 is a discharge spout 49. The container is positioned in such a manner that the discharge spout will be in a coaxial position over the container in station I.

Referring now to FIGS. 8, 9 and 10, there is illustrated in the position of station III a T-piece 51 which is connected at its base 51b to shelf 1 by screws and springs 51'.

The upward disposed leg 51a or member of the T-piece 51 is parallel to and displaced to the left of the axis 53'. The upper end of said leg 51a intersects a member 54 which serves as a housing for a gear 52 pivoted to a pin 53.

Member 54 is aligned with axis of pin 27 of collar 28 at station III. Pin 53 extends from the housing 54 towards the collar 28 and terminates in a forked member 55 adapted to connect with the edge or rim of said collar 28, as shown on FIG. 8. The gear 52 meshes with the toothed portion 56a of rack 56 which can slide longitudinally and is supported along its length with the T piece. On the end 56b of rack 56, which is spaced from the toothed portion 56a thereof, is secured a piston 57 contained slidably within a cylinder 59. The cylinder 59 is bolted to leg 51a of T-piece 51 at a location opposite the member 54.

A spring 58 is disposed between the piston 57 and the leg 51a and normally maintains the piston 57 in a predetermined position such that member 55 will be in a position to engage the edge or rim of collar 28 at station III.

The chamber 59a formed (to the left in FIG. 10) within cylinder 59 and divided by piston 57 from the chamber 59b houses the spring 58, and is connected with a fluid duct 59c in a manner and for a purpose which will be explained hereafter.

Hydraulic pressure in the cylinder 59 serves, in use, to squeeze the spring 58 against its bias, moving the rack 56 to cause the forked member 55 to rotate through 180°. This action rotates collar 28 and thus the strainer 36, which is positioned with its open end upwardly directed, is rotated to a position in which it is inverted as shown in FIG. 8, the spring 57 maintaining the strainer 36 with collar 28.

Nozzles 60 (preferably four in number) are provided to enable the interior of the strainer to be sprayed and in addition a pair of nozzles 61 are provided to enable the exterior of the strainer to be sprayed as illustrated in FIGS. 8 and 9. The operating period of the nozzles will be referred to below.

Referring now to FIGS. 11 to 13, at a location below station IV on the shelf 1 is mounted a cylinder 62 (FIG. 12) having a piston 63 slidable therein. One side 62a of the cylinder is connected to a pressure fluid duct, (indicated on the left in the drawings). The piston rod 63' of piston 63 is provided (on the side opposite to the duct) with an extension generally indicated by reference number 64, same extending beyond the cylinder 62 and carries a horizontal cross piece 64', fitted with a horizontal member 65 having a hook-like end 66.

Crank 19, rotatably mounted on portion 17 of stem 2 carries on its arm a pivot pin 67 to which is pivotally attached a pawl 68. The pawl 68 is adapted to engage

any one of the four notches 74 of gear collar 69 to rotate same, and also rotate therewith the hub 18. The tail piece 68' of the pawl 68 is connected to a spring 70 and to a moving arm 71 formed integral with the crank 19.

A coil spring 72 externally surrounds cylinder 62 and abuts (on the right in the drawings) a flange member 108 integral with the cylinder. The other end of the spring abuts a floating flange 108b which is connected to the cross-piece 64' by means of two rods 73.

The piston 63 is normally positioned as indicated in FIG. 11 when the cylinder 62 is not pressurized. In this position, the pawl 68 is located in one of the notches 74 and the catch of hook 66 abuts the pivot pin 67.

When the pressure of the fluid entering cylinder 62 causes the piston 63 to move, the member 65 is moved to the right and the hook 66 thereby is moved to push against pivot pin 67. Movement of the hook moves all of the other members to cause rotation through 90° of the collar 69 and the hub 18, this in turn rotates the strainers 36 through 90°.

When the fluid pressure is relieved, the action of spring 72 returns all the members of the assembly just described to their original positions as shown in FIG. 11. This return movement does not, however, affect gear collar 69 because the pawl 68, during its return travel, slides on the back of the collar 69 until it enters the next notch 74 thereof.

Hydraulic systems

Referring now to FIG. 15, the circuit of pump 76 is a closed circuit, that is, the pump 76 aspires, from tank 78 first fluid, that is, water emulsified with silicones, then compresses the first fluid at the positions where required. In theory, all of the first fluid, after having been utilized, returns to the reservoir 78.

The circuit of pump 77 is an open circuit. The pump aspires from tank 78' (which can be connected to a water source, by any known means, say from a water main, purified drinking water) feeds such drinking water to the location where used. The major portion of said drinking water, hereinafter referred to as the second fluid, is used for the brewing of coffee and, the remainder is used to flush the ground coffee out of the used strainers 36 at position III.

On the circuit of pump 76 (inflow side) two groups of valves, indicated by the references R and S (see FIG. 15), are inserted in parallel (for the purposes already mentioned, and also for the purpose yet to be described).

As shown in FIG. 15, the valve group R includes a valve 79, through which the inflow duct 82 of the pump connects with cylinder 44. This cylinder controls the inflow and outflow of hot water for brewing coffee and flow to the chamber 11 of a cylinder 80 yet to be described.

Valve 79 is normally retained in a closed position by spring 81. Downstream of valve 79 is located a valve 83 by way of which duct 82 is connected with return duct 84 and thus with tank 78.

A two armed lever 85, pivoted at 86 adjacent the valves and operated by spring 88, which abuts one of its arms, maintains valve 83 open against the pressure of spring 89. This arrangement does not have any effect on valve 79.

The group of valves includes two valves 90 and 91 mounted in succession, much as in the manner described with reference to valves 79 and 83.

The duct 82 (inflow of pump 76) is connected by way of duct 98 and fitting 92 with the various hydraulic cylinders (auxiliary servomotors) by way of valve 90, which is normally held closed by spring 93, while downstream of said valve a second valve 91 is provided. The valve 91 connects duct 82 with the outflow duct 84 and thence to tank 78. The valve 91 is biased closed by spring 96.

A two armed lever 94 pivoted at 95 is held in position by spring 97, so as normally to maintain valve 91 in

an open position despite the pressure of spring 96. This arrangement has no effect on valve 90.

The inflow of pump 76 is by way of duct 82, valve 90, valve 91, duct 98 and fitting 92, and is connected respectively with that side of servomotor cylinder 62 where the piston comes into contact with spring 72. This arrangement serves to control the intermittent movement of the piston which in turn controls the rotation of the four strainer holders 36 and with the chamber of a hydraulic servomotor cylinder 99 (see FIG. 14), within which cylinder slides a piston 100. The cylinder contains a spring 101. The piston rod of piston 100 extends into the coffee grinder 50. The piston rod normally serves to maintain a coffee outlet duct closed.

A further duct from fitting 92 is attached to a cylinder 162 within which slides a piston 161 the piston rod of which, when operated, serves to release a single spatula for stirring a cup of coffee.

A still further duct connects member 92 to a cylinder 165 within which is located piston 164 and spring 166. This arrangement serves to control the dispensing of sugar from container 158. Valve 102 also served by a duct from fitting member 92, is usually maintained, under the influence of spring 103, closed. An outlet from the valve 102 communicates with one side of cylinder 23. Below cylinder 23, is located the strainer of station II. The valve 102 also connects with one side of cylinder 59 which latter contains piston 57. As described above the piston 57 serves to control, by the rack and pinion drive, the flipping movement of the strainers at station III. Member 92 may be described as a multi-passaged diverter means.

Valve 102 is fixed to shelf 1 in a position below, and substantially in correspondence with cylinder 62 (FIG. 11).

The stem 104 of valve 102 extends beyond the valve body and there contacts one arm of two armed levers 105 (pivoted at 106), the other arm of the lever is fork shaped and extends through a slot 105' in shelf 1 to emerge in the path of rollers 107, at points directly opposite to floating flange 108b.

When piston 63 slides in cylinder 62 to press on spring 72 and thus move to the right the strainers are moved through 90° to advance them one station. The movement is in a clockwise direction (see arrow of FIG. 13). During this movement, rollers 107 contact lever 105 (see FIG. 11 dotted line, 108b') so as to cause an angular movement of said lever 105. This movement causes the said one arm to push piston rod 104 to open valve 102 thereby compressing spring 103, and causing a direct connection between the inflow side of pump 76 and the cylinders 23 and 59.

Referring now to the circuit of pump 77, the inflow duct 109 connects by way of reduction valve 113 with chamber 110 of hydraulic cylinder 80, whose other chamber 111 is liable to be connected with the inflow of pump 76 by the way of the group of valve groups.

The chamber 110 is provided with a spring 112 which acts on piston 117 in a manner which will be described below.

Downstream of the valve 113 is located a second reduction valve 114, through which the inflow of the pump is put in connection with chamber 10 by way of duct 116 which contains the second fluid used to brew the coffee.

Downstream of valve 114 is located an expansion valve 115, through which excess second fluid is returned to the tank 78', from which it is aspired by suction of pump 77.

The inflow of the pump 77 upstream of the three valves 113, 114 and 115 is by way of duct 120, said duct 120 being connected with the nozzles 60 and 61 by way of valve 121. This valve is normally held closed by spring 122. Second fluid from these nozzles 60, 61 is used to flush each strainer 36 which it stops at station III.

Referring now to cylinder 80, this provided with a piston 117 whose piston rod is provided with an extension stem 117' which extends from chamber 110. The end of the extension 117' is provided with a transverse member 119 from which extends rod 118.

The extension 118 co-operates with valve 121 in such a manner that when extension 118 rises it opens valve 121 by impinging upon the stem 121' thereof and thus compressing spring 122. The transverse member 119 co-operates, at one side 119a, with arm 123 of a square, sectioned L-lever 123/124 which is pivoted at 125. The arm 124 of the L-lever is arranged to be connectable with lever 94 which latter regulates valve group S. When the arm 124 is connected to lever 94 it holds the latter in a position such that the spring 97 is compressed. When spring 97 is compressed, valve 90 is open and valve 91 is closed. A second L-lever 126/127, pivoted at 128, is provided adjacent the extension 118 and the arm 127 thereof is arranged to abut the lever 94 when the spring 97 is compressed. Also adjacent the extension 118 is a similar third L-lever 129/130 which is pivoted at 131. The pivot point of lever 129/130 is carried by a member 132 secured to stem 134 which extends from a cylinder 133. The stem 134 is attached to a piston 137 slidable within cylinder 133. A spring 136 within cylinder 133 normally holds the piston at the upper end of the cylinder 133. Above the piston 137 is a chamber 133' connected by means of a conduit 133a to the chamber 23a of cylinder 23. The cylinder 133 thus functions as a pressostat.

The arm 130 of the lever 129/130 is arranged to be connectable with a lever 138 which latter is pivotally mounted on a member 132 which is secured to stem 134 in a position in which it can cooperate with lever 85. The lever 85 serves to regulate the group of valves R. When the lever 85 is to be moved from its normal position in which valve 79 is closed and 83 open, to a position in which valve 79 is open and valve 83 is closed, the lever system 129/130, 138 is moved by the member 119.

A spring 139 is inserted between arm 129 and an abutment 140 on member 132. The spring normally holds the lever 130 in abutment with the lever 138 as shown in FIG. 15.

The core 141' of a solenoid 141 is located adjacent the lever 94 and substantially below the spring 97. When the coil of the solenoid is energized by the insertion of a coin into the device D, the core 141' is moved to operate the valve group S.

The coffee making machine according to the invention operates in the following manner:

A coin is dropped into the slot 150 and, assuming the coin is not rejected and returned to the depositor through the chute 151 to the basin 152, the dispensing operation commences.

The core 141' of the solenoid 141 compresses spring 97 which causes the lever 94 to rotate clockwise on its pivot 95 from the position indicated on FIG. 15. The arm 127 of lever 127/128 becomes engaged with the lever 94 to maintain it in the position to which it has been moved by the core 141 after the electrical circuit has been deenergized. Energization of solenoid 141 causes switch 142 to close to energize electric motor 75, thus actuating pumps 76 and 77.

Pump 77 pumps second fluid into duct 120, and since valve 122 is shut, the second fluid passes, via valve 113 into upper chamber 110 of cylinder 80 via duct 142'. Pressure in chamber 110 causes the piston 117 to move and second fluid enters valve 83 via duct 142'. Valve 79 is closed and duct 84 leads to tank 78. Second fluid in valve 113 also serves to open valve 114 and thus second fluid is fed, under pressure, via duct 116, to chamber 10 in which it is heated by resistance heater 14 to the temperature selected for brewing the coffee. Valve 38

remains closed and thus second fluid cannot pass to cavity 5 or spray head 6.

Pump 76, by way of duct 82, pumps first fluid to open valve 90 of group S and then, by way of valve 91, and duct 98, to fitting member 92. The return valve 91 remains shut.

First fluid from fitting member 92 also passes to the hydraulic cylinder 99, where it shifts the piston 100 against the bias of spring 101 and thus permits communication between the coffee container 145, the grinder 50 and, also, opens the discharge spout for ground coffee to release a predetermined quantity thereof through the fitting 49 to a strainer which is located at station I.

The arrangement is such that the predetermined quantities of first fluid and coffee are so metered that as soon as the strainer in station I is filled with coffee, the extension 65, integral with piston 63 of cylinder 62, receives an impulse by the pressurized first fluid fed to cylinder 62 through fitting member 92. The hook 68 of extension 65 contacts pivot 67 and, by way of pawl 68, causes clockwise rotation of hub 18. The strainer located at station I and thus filled is moved to station II to become located between spray 6 and surface 6' of radial extension 25' (see FIG. 6).

The floating flange 108 of cylinder 62 has now reached the position indicated in FIG. 11 in dotted line and thus the lever 105 has pivoted on pivot 106 and will keep an open valve 102. Pressure on piston 23 is therefore maintained.

Since pressure remains on piston 23, first fluid from pump 76 will cause said piston 23 to lift against the pressure of spring 24 and the strainer 36 will be carried toward and held tightly against gasket 7 which surrounds spray head 6.

The pressure generated in cylinder 23 is transmitted via chamber 133' piston 137 of cylinder 133 by duct 133a. Piston 137 thus slides, in cylinder 133 (the pressostat) against the pressure of spring of spring 136 and thus the member 132, which is integral with the stem 134, also is moved. Movement of member 132 causes small lever 138 to bear against lever 85, rotating same around pivot 86 and thus regulating group of valves R in an anticlockwise manner. Movement of lever 85 overcomes the bias of spring 88. The lever 85 is held in the position just referred to until such time as it becomes disengaged by the lever 138 in a manner disclosed below, that is in response to the movement of member 119.

When the conditions just referred to apply, valve 79 is open and 83 is shut. Pressurized first fluid from pump 76 now passes to cylinder 44 by way of duct 82, valve 79, the upper end of valve 83 and conduit 82a. Since valve 83 is closed, first fluid cannot return to tank 78. Piston 43 is now moved by the first fluid against the bias of spring 45, thus closing discharge valve 41, moving stem 42 and opening valve 38 to allow hot second fluid, to pass from chamber 10 through pipe 9 to the cavity 5 and spray head 6. As stated above, the strainer 36 has been filled with powdered coffee grains at station I and, at station II has been pressed against the gasket 7 surrounding spray head 6.

The second fluid is forced through the coffee grains and thus infused coffee now passes from the strainer 36 to funnel 26 and trough 27' to fill the cup which is located below the strainer 36 within the chamber 143.

The hydraulic servomotors 161/162 and 164/165 have also been actuated and thus sugar has been dispensed to basin 155 together with a spatula for stirring the coffee.

Contemporaneously, pressurized first fluid from pump 76 has passed by way of duct 142', to reach the lower chamber 111 of hydraulic cylinder 80, and owing to the fact that the specific pressure created is generally greater than that present in upper chamber 110 (due to differences in the surface areas of the pistons) piston 117 moves upwardly and thus member 119 releases arm 123 of L-lever 123/124 which, actuated by its return spring 97 then ro-

tates in an anticlockwise direction to contact, by means of its hook end, the extremity of lever 94. The lever 94 is maintained in the lowered position by the action of over-bearing arm 127 of lever 126/127.

In the meantime, while the strainer on station II remains in position, valve 102 is open and thus pressurized first fluid acting against piston 57, against the pressure of spring 58, has caused the strainer in station III to be inverted. The strainer is maintained in that position until the reduction of pressure in the cylinder 59 against the piston 57 takes place.

Piston 117 during its upward movement together with its extension 118 engages stem 121' to open valve 121 thus allowing pressurized second fluid originating from pump 77 to pass through nozzles 60 and 61 simultaneously to flush opposite sides of the inverted strainer 36 which is located at section III (as shown in FIGS. 8 and 9).

Further upward movement of piston 117 causes the member 119 to abut arm 126 of lever 126/127 which under the action of a return spring causes it to disengage from lever 94. Lever 94 maintains its position however since it is engaged by the hook end of arm 124 of lever 123/124. The arm 124 is maintained in position by a return spring 97.

As the member 119 reaches the upper limit of its movement it abuts arm 129 to rotate it in a clockwise direction against the bias of spring 139. This movement causes disengagement of lever 138 and thus the lever 85 of valve group R can return to its original position under the influence of spring 88.

Valve 79 is now shut and valve 83 is open. Cylinder 44 is in discharge condition through open valve 83 and ducts 84' and 84, and the flow of first fluid is arrested by valve 79 since this valve is closed.

Valves 38 for the inflow of pressurized water to the strainer is closed and the discharge valve 41 is open. The second fluid eventually left in the strainer refluxes back through bores 9 and 8, through holes 47 to the spout 49' (see FIG. 6) for discharge.

The flow of coffee to the disposable cup is discontinued. Due to the closing of valve 79 and the opening of valve 83, the pressure has dropped in chamber 111. High pressure is present in chamber 110 and in consequence piston 117 is pushed downwardly by the second fluid and the bias of spring 112.

Downward movement of the piston 117 moves the extension 118 of the valve 121 which closes under the influence of the spring 122 thus preventing second fluid from reaching nozzles 60 and 61. The member 119 releases the lever 129/130 which, under the bias of spring 139, resumes its initial position.

Finally the member 119 abuts the arm 123 of lever 123/124 to release lever 94.

Electric switch 142 opens, motor 75 stops and this causes the hydraulic servomotors to stop.

The disposition of parts is such that valve 91 of the group S is open and for this reason the duct 99' which feed cylinder 99 of the coffee dosing grinder 50 and the one, duct 62a', controlling the intermittent rotation of strainers 36 are connected to discharge. The cylinders 163, 165 and their pistons, 161 and 164 which control the distributing of sugar and the stirring spatulas are returned under the influence of the corresponding springs. Also, cylinder 23 which holds the strainers in station II is returned to its initiate condition.

The cylinder 59 used to invert the strainers at station III, is still open to valve 102. Toward the completion of the return travel of piston 62, the valve 102 is closed. The strainer of station II is now free to move to station III, the strainer at station III, during the return travel of the piston 63 is righted and is ready for movement to station IV.

The cycle is now ready to be repeated.

In summary, the invention provides a coin operated coffee beverage vending machine which includes coin re-

ceiving and handling means, first switch means, including a lever actuating mechanism, operable upon a selected lever on being energized by the acceptance of a coin deposit in said coin receiving and handling means; first and second fluid system, said first fluid system carrying water for brewing and rinsing purposes and said second fluid system carrying hydraulic fluid, said first and second fluid systems including first and second pumps operable to move said respective fluids, a motor energized upon operation of said selected lever to place the said first and second pumps in operative condition, carrier means arranged for step-wise rotation through a series of operating stations, a plurality of strainers carried by said carrier means and arranged to rotate therewith through said series of operating stations, said series of operating stations comprising a loading station, a brewing station, a discharge and rinsing station and a ready station, each station arranged spaced substantially 90° relative the others, a plurality of hydraulically operated mechanical systems each having a specific function and arranged to be operated by the flow of respective fluids from said first and second fluid systems, said mechanical systems comprising dosing means for supplying metered quantities of ground coffee to a strainer as same is disposed at the loading station, translating means for moving the carrier in 90° stepwise increments, temporary inverting means operable upon the strainer disposed at the discharge and rinsing station, cup-dispensing means to locate a disposable cup immediately below that strainer located at the brewing station, auxiliary implement and condiment dispensing means, distributing means having a delivery end control valve means, and including heating means for feeding hot fluid under pressure of said first fluid system to the strainer at the brewing station, sealing means for effecting a sealing engagement of said strainer at the brewing station with said distributing means at the delivery end thereof, said sealing means comprising a hydraulically operated cylinder operated by the second fluid system, first plural valve means for controlling flow of water in said first fluid system, second plural valve means for controlling flow of hydraulic fluid in said second fluid system, plural pivoted-lever means, including said selected lever, multi-passaged diverter means arranged between the second plural valve means and selected ones of the said hydraulically operated mechanical systems, and said plural pivoted lever means, including said selected lever, operable to direct flow of hydraulic fluid selectively to said selected ones of said hydraulically operated mechanical systems via said diverter means, said selected ones of said mechanical systems being said dosing means, said translating means, said implement and condiment dispensing means, said temporary inverting means and said sealing means, said first pump operable to direct water through said first plural valve means simultaneously to the tank of said distributing means for heating thereof and to control valve means to enable delivery thereof, a hydraulic control cylinder which includes a spring biased piston reciprocable therein and dividing said cylinder into first and second compartments, a trip lever rideable on said piston exterior of said cylinder and operable upon said plural pivoted-lever means, including said selected lever, to return said selected hydraulically operated mechanical systems to their initiate condition subsequent to the elapse of a predetermined time period and, simultaneously to act upon said control valve means of the distributing means whereby to divert a portion of said water of said first fluid system, a first group of nozzles positioned below the carrier means and aligned with the inverted strainer at the discharge and rinse station and a second group of nozzles arranged above said inverted strainer at said discharge and rinse station, said nozzles receiving said diverted portion of said water of said first fluid system simultaneously, whereby deposit of a coin results in concurrent energization of said first and second pumps and the actuation of all systems.

What I claim is:

1. A coin operated automatic vending machine to brew and dispense hot coffee in individual cups, actuated only by the insertion of a coin in a slot of a box-like housing for the dispensing apparatus, said housing having a floor and a shelf located in the housing at about mid-height thereof, a composite assembly disposed on the shelf for the brewing of coffee drinks from one side of said assembly, a coin receiving assembly fixed on said shelf, a door at the front of the housing carrying a device to distribute stirrers one at a time via a slide accessible through an opening in the face of the housing, electric motor drive for pump means adapted to be energized by the deposit of a coin, a tank for purified water and a separate tank for hydraulic fluid, a container to receive used coffee powder, a sugar distributing device, a cup distributing device, an aperture in the door for removal of a filled cup, a slanting trough leading from the composite device to the cup for filling thereof, said composite device for the loading, brewing, rinsing and storage operations of said machine comprising, a rotatable hub intermittently movable in a determined direction by a hooked two arm lever adapted to be moved by a further lever regulated by a pressure piston having a reciprocating travel, each movement of the hub being through 90° to enable a strainer to be located at a predetermined position, strainer holders at the extremity of arms formed on the hub, a doser electro-grinder above one strainer station, a distributing spray for coffee brewing water connected with a water receiving and heating tank by means of a normally closed valve located at a further strainer station, strainer flushing nozzle to flush the strainers after each use thereof; an assembly including a first closed hydraulic circuit regulated by a first pump actuated by said electric motor for the control of all of the hydraulic servomotor cylinders needed and coordinated by the different functions of said composite device, a second hydraulic circuit adapted to receive purified water, and controlled by a second pump also actuated by said electric motor simultaneously as the first pump, said second pump being arranged to furnish purified water at a selected pressure to said receiving and heating tank and also to furnish purified water for the flushing of strainers after each use thereof through a duct and valve, a first valve group inserted in the closed circuit of the first pump, a second valve group inserted in the circuit of the second pump, a spring biased lever stressed by return spring action adapted normally to maintain said valves in discharge position in said hydraulic cylinders, hook means associated with said lever and adapted, with said return force or pressure, to retain said lever at the position of the closing of an electric switch in an electric circuit of said electric motor drives and with the first and second group of valves set in working position for the group of valves inserted in said first closed hydraulic circuit and for the said cylinders of said hydraulic servomotors, a lever under the stress of a return spring adapted normally to maintain one of said first group of valves shut on the outflow stage period and open another one of said first group of valves on the inflow stage period, a hook device adapted to contact a further lever biased to position the inflow valve shut and outflow valve open, a hydraulic control cylinder having a piston slidable therein, one chamber of said hydraulic control cylinder being connected with the outflow of the second pump by means of the second group of valves, the said piston and cylinder being in combination with the piston of a further cylinder adapted to retain a strainer in position below the distributing spray, and the piston rod of the last mentioned piston extending beyond the cylinder thereof to contact a lever adapted to control the second group of valves when a pressure is present in the servomotor cylinder to hold the strainer in a leakproof manner below said spray, a piston rod of said first cylinder projecting from said first cylinder

der to cooperate successively with one engagement for the opening of the valve for the flushing of strainer at one of said stations and for the releasing of a lever adapted to release said first group of valves and for engagement with means for the releasing of the lever adapted to control the second group of valves.

2. A coin operated automatic vending machine as claimed in claim 1 including a pump outflow conduit to said second group of valves, a servomotor circuit in said outflow adapted when operative to close the discharge spout for the ground coffee grains, of the doser-grinder, said discharge spout being co-axial with a strainer at one station, a servomotor cylinder adapted to control the intermittent rotation of said hub by means of a valve normally held shut by the action of a spring, said servomotor cylinder piston being arranged to cause the strainer at said station to be held against said spray, a further servomotor cylinder adapted to operate the inversion mechanism for said strainers at a further station, a lever operated valve operably associated with a floating piston of that hydraulic servomotor which is adapted to rotate said hub.

3. A coin operated automatic vending machine according to claim 1 in which the control lever of said first group of valves is actuated by means of the core of a solenoid, the coil of which becomes energized upon the insertion of a coin.

4. A coin operated automatic vending machine according to claim 1, characterized by the insertion of a valve between said receiving and heating tank used for brewing the coffee and the distributing spray, the valve being coaxial with the discharge valve of the distributing spray, a control spring maintain the valve in a closed position and a second valve actuated by servomotor cylinder and normally maintained in the open position, the arrangement being such that as the first valve opens the second valve closes, and vice versa.

5. A coin operated automatic vending machine, according to claim 1, characterized in that said hub is provided with four radial holes set at 90° spacing on each one of which the pivot of a collar can be introduced whilst allowing free rotation, means being provided to retain the hub so as to be engaged and disengaged intermittently by the collar being inserted into a strainer holder and spring means axially to hold said strainer holder in place.

6. A coin operated automatic vending machine according to claim 1 in which the leakproof positioning of the strainer against the gasket at one of said stations is achieved by providing a seating for said gasket around the periphery of a member provided with a cavity in which is located the distributing spray, said cavity communicating with the heating and receiving tank and said cavity being coaxial with the coffee dispensing station of the strainer, the upper face of the cavitated member forming a cylindrical means coaxial with which is a hydraulic servomotor cylinder, the piston of which is retained in position by a return spring.

7. A coin operated vending machine as claimed in claim 1 in which the strainer is located within a funnel-like device held below the spray and a pouring spout integral with the funnel-like member.

8. A coin operated automatic vending machine according to claim 5 characterized in that at one station there is provided a fork piece adapted to receive the rim of the collar, the fork being attached to the pinion of a servomotor operated rack and pinion mechanism, the arrangement being such that the strainer may be inverted.

9. A coin operated automatic vending machine including a housing having therein a shelf-like horizontal plate upon which is mounted a composite device for the brewing of coffee, there being above the shelf a coin receiving mechanism to which coins pass along a chute, a dispenser of spatula-stirrers adapted to release one stirrer each time the machine is operated, there being below the shelf, a

motor, first and second pumps operable by said motor, a first reservoir for purified water and a second reservoir for fluid which has been emulsified with silicones and a bucket to receive used coffee powder; and the interior face of a hinged front part of the housing mounting a device to dispense individual lumps of sugar with each drink and a device for the distribution of cups which are arranged to fall into a niche located below a spout from which the coffee is adapted to be dispensed; a composite device in the form of a rotating hub moving intermittently in a determined direction by steps of 90° through four operating stations, said hub carrying four arms set at right angles to each other, each arm carrying a strainer of a capacity sufficient to hold a requisite quantity of powdered coffee, said four operating stations for the strainers including a grinder-doser station, a brewing station including a water spray for supplying water to the coffee, connected with a pressurized hot water tank by way of a normally closed valve, a rinsing station including nozzles for the washing of both sides of used strainers and a ready station to hold a clean strainer for transfer to the doser station, a normally closed first hydraulic circuit including hydraulic servomotors, controlled by said first pump, a second hydraulic circuit fed with drinking water and controlled by a second pump actuated simultaneously with the actuation of the first pump and arranged to supply water at the required pressure to the hot water tank for brewing the coffee, a valve normally closed adapted to be actuated to allow water to pass to the used strainers for washing same, a first valve group located in a closed circuit of the first pump, a first spring loaded lever adapted to maintain the valves in a discharge position to supply said silicon emulsified fluid to the hydraulic cylinders of the servomotors, a hook-like pivoted member adapted to retain the lever in position to release it to reverse the valves, an electric circuit for said electric motor, including a switch closed on deposit of a coin in the machine and said electric motor adapted to operate to direct a supply of said fluid to said valves and to a second valve group associated with said closed fluids circuit for the servomotors, a spring loaded lever arranged to maintain a valve in a normally closed position on the outflow circuit and to maintain a further valve in a normally open position in the inflow, a second hook-like member arranged normally to hold said valves in their normal positions, a hydraulic cylinder including a piston, one chamber of the cylinder being connected with the outflow of the second pump to supply the water for brewing the beverage, the other chamber being connected with the discharge, or with the outflow of the pump of the closed circuit of the servomotor cylinders, there being also provided a cylinder having a piston having with a piston rod extending from the cylinder and combined therewith, a servomotor cylinder which controls the pressure applied to hold a strainer in position to receive purified water for infusing the coffee to brew same, the piston rod serving also to control the sequence of operation of the valves.

10. A coin operated automatic vending machine according to claim 5 in which, between the cylinder and the pump which pressurizes the water used for brewing of coffee, there is provided a reduction valve adapted to control the water pressure of water feed for brewing.

11. A coin operated automatic vending machine according to claim 1 in which the second pump used to pressurize water used for the infusion, operates on only purified water and the first pump operates only on water which has been emulsified with silicones.

12. A coin operated coffee beverage vending machine which includes coin receiving and handling means, first switch means, including a lever actuating mechanism, operable upon a selected lever on being energized by the acceptance of a coin deposit in said coin receiving and handling means; first and second fluid systems, said first fluid system carrying water for brewing and rinsing purposes and said second fluid system carrying hydraulic

fluid, said first and second fluid systems including first and second pumps operable to move said respective fluids, a motor energized upon operation of said selected lever to place the said first and second pumps in operative condition, carrier means arranged for step-wise rotation through a series of operating stations, a plurality of strainers carried by said carrier means and arranged to rotate therewith through said series of operating stations, said series of operating stations comprising a loading station, a brewing station, a discharge and rinsing station and a ready station, each station arranged spaced substantially 90° relative to the others, a plurality of hydraulically operated mechanical systems each having a specific function and arranged to be operated by the flow of respective fluids from said first and second fluid systems, said mechanical systems comprising dosing means for supplying metered quantities of ground coffee to a strainer as same is disposed at the loading station, translating means for moving the carrier in 90° stepwise increments, temporary inverting means operable upon the strainer disposed at the discharge and rinsing station, cup-dispensing means to locate a disposable cup immediately below that strainer located at the brewing station, auxiliary implement and condiment dispensing means, distributing means having a delivery end control valve means, and including heating means for feeding hot fluid under pressure of said first fluid system to the strainer at the brewing station, sealing means for effecting a sealing engagement of said strainer at the brewing station with said distributing means at the delivery end thereof, said sealing means comprising a hydraulically operated cylinder operated by the second fluid system, first plural valve means for controlling flow of water in said first fluid system, second plural valve means for controlling flow of hydraulic fluid in said second fluid system, plural pivoted-lever means, including said selected lever, multi-passaged diverter means arranged between the second plural valve means and selected ones of the said hydraulically operated mechanical systems, and said plural pivoted lever means, including said selected lever, operable to direct flow of hydraulic fluid selectively to said selected ones of said hydraulically operated mechanical systems via said diverter means, said selected ones of said mechanical systems being said dosing means, said translating means, said implement and condiment dispensing means, said temporary inverting means and said sealing means, said first pump operable to direct water through said first plural valve means simultaneously to the tank of said distributing means for heating thereof and to the control valve means to enable delivery thereof, a hydraulic control cylinder which includes a spring biased piston reciprocable therein and dividing said cylinder into first and second compartments, a trip lever rideable on said piston exterior of said cylinder and operable upon said plural pivoted-lever means, including said selected lever, to return said selected hydraulically operated mechanical systems to their initiate condition subsequent to the elapse of a predetermined time period and simultaneously to act upon said control valve means of the distributing means whereby to divert a portion of said water of said first fluid system, a first group of nozzles positioned below the carrier means and aligned with the inverted strainer at the discharge and rinse station and a second group of nozzles arranged above said inverted strainer at said discharge and rinse station, said nozzles receiving said diverted portion of said water of said first fluid system simultaneously, whereby deposit of a coin results in concurrent energization of said first and second pumps and the actuation of all systems.

13. The machine as claimed in claim 12 in which said hydraulic fluid is siliconized water and said fluid systems are maintained independent and unmixed.

References Cited

UNITED STATES PATENTS

| | | | |
|-----------|---------|----------------|---------|
| 1,390,008 | 9/1921 | Arduino | 99—289 |
| 2,014,325 | 9/1935 | Grillo | 99—289 |
| 2,558,522 | 6/1951 | Knapp | 99—283 |
| 2,599,455 | 6/1952 | Husemann | 134—131 |
| 2,879,811 | 3/1959 | Parraga | 99—283 |
| 2,910,928 | 11/1959 | Rota | 99—289 |
| 2,955,527 | 10/1960 | Collins et al. | 99—289 |
| 3,055,286 | 9/1962 | Valente | 99—289 |

| | | | |
|-----------|--------|--------|--------|
| 3,143,058 | 8/1964 | Jannin | 99—283 |
| 3,254,589 | 6/1966 | Little | 99—289 |

FOREIGN PATENTS

| | | |
|-----------|---------|---------|
| 1,184,141 | 2/1959 | France. |
| 506,258 | 12/1954 | Italy. |
| 509,257 | 1/1955 | Italy. |
| 509,543 | 1/1955 | Italy. |

WALTER A. SCHEEL, *Primary Examiner.*

S. P. FISHER, *Assistant Examiner.*