

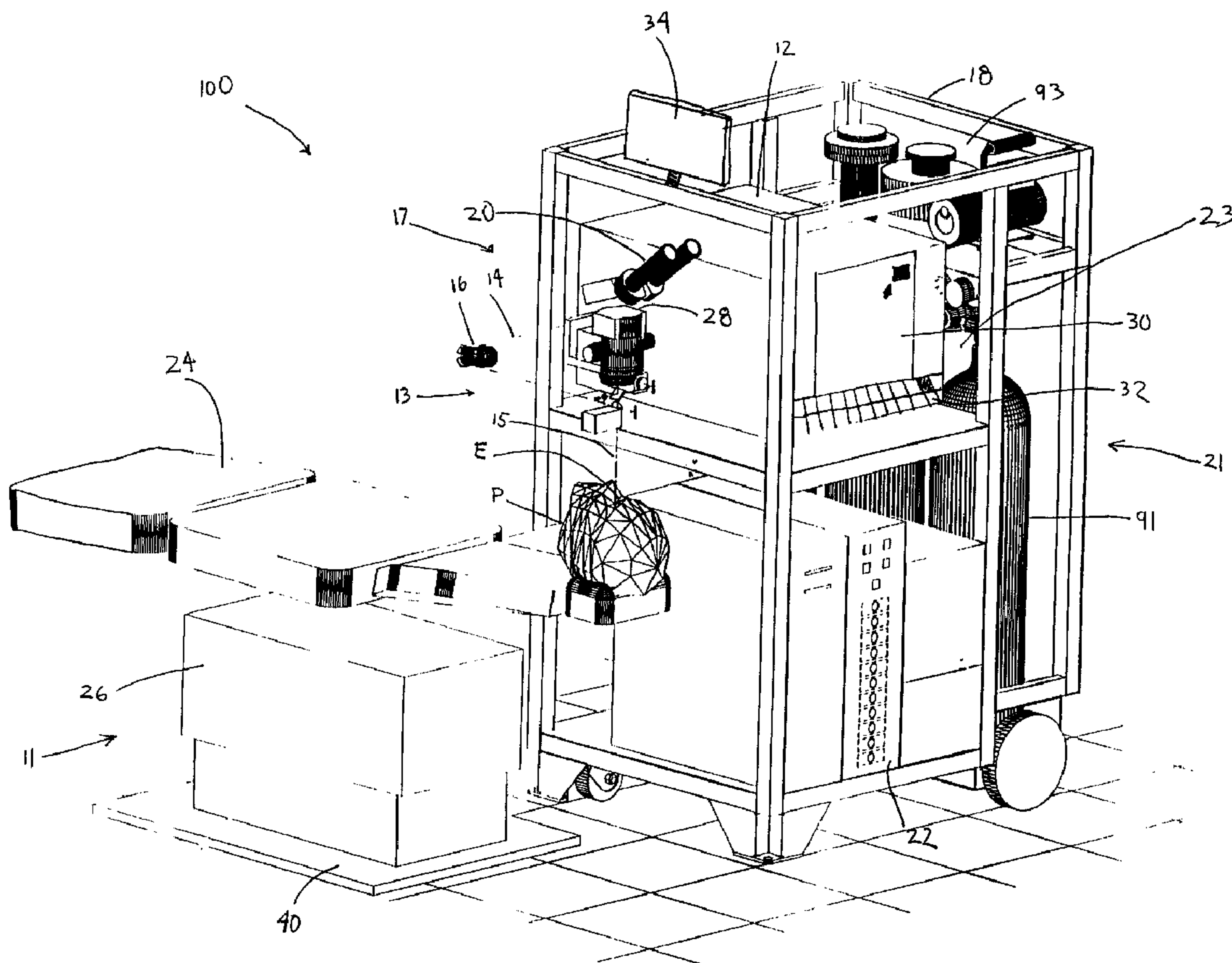

(86) Date de dépôt PCT/PCT Filing Date: 2000/03/28
 (87) Date publication PCT/PCT Publication Date: 2000/10/12
 (45) Date de délivrance/Issue Date: 2011/09/20
 (85) Entrée phase nationale/National Entry: 2001/08/30
 (86) N° demande PCT/PCT Application No.: US 2000/008254
 (87) N° publication PCT/PCT Publication No.: 2000/059402
 (30) Priorité/Priority: 1999/04/07 (US60/128,122)

(51) Cl.Int./Int.Cl. *A61B 18/18* (2006.01),
A61F 9/01 (2006.01)
 (72) Inventeurs/Inventors:
CLAPHAM, TERRANCE N., US;
COWPERTHWAIT, MICHAEL, US;
HOFER, RICHARD A., US;
SCRAMAGLIA, ERIK, US
 (73) Propriétaire/Owner:
VISX, INC., US
 (74) Agent: SMART & BIGGAR

(54) Titre : INTERFACE AMELIOREE POUR CHIRURGIE OCULAIRE AU LASER
 (54) Title: IMPROVED INTERFACE FOR LASER EYE SURGERY



(57) Abrégé/Abstract:

This invention is a laser surgery system (100) having a computer control system (22) coupled to a laser subsystem (13), and a patient seat (24). The control system (22) is coupled to the laser through a laser alignment system (17). The control system (22)

(57) Abrégé(suite)/Abstract(continued):

can be coupled to the patient seat (24) through a patient alignment system (11). The control system (22) sends a nominal position signal to move the patient seat (24), laser subsystem (13), or both so that the patient's first eye is moved into substantial alignment with the laser beam axis. The control system (22) can send a second nominal signal to move the patient's second eye into substantial alignment with the laser beam axis. The control system (22) can optionally comprise both an operator display (23), and an assistant display (34). The assistant display (34) provides real time information to an assistant positioned at an assistant station adjacent the patient seat. The control system (22) can be programmed to display edit fields with different colors to provide an obvious indication of the refractive information of the eye. The control system (22) can comprise an operator input for providing a predetermined secondary ablative treatment. If it is determined that the first ablative treatment did not completely remove the epithelial layer from a target region, the operator actuates the operator input to deliver the secondary ablative treatment.

(12) INTERNATIONAL APPLICATION PUBLISHED UNDER THE PATENT COOPERATION TREATY (PCT)

(19) World Intellectual Property Organization
International Bureau



(43) International Publication Date
12 October 2000 (12.10.2000)

PCT

(10) International Publication Number
WO 00/59402 A3

- (51) International Patent Classification⁷: **A61B 18/18** (74) Agents: **WONG, Craig, P.** et al.; Townsend and Townsend and Crew LLP, 8th floor, Two Embarcadero Center, San Francisco, CA 94111-3834 (US).
- (21) International Application Number: **PCT/US00/08254**
- (22) International Filing Date: **28 March 2000 (28.03.2000)** (81) Designated States (*national*): AE, AG, AL, AM, AT, AU, AZ, BA, BB, BG, BR, BY, CA, CH, CN, CR, CU, CZ, DE, DK, DM, DZ, EE, ES, FI, GB, GD, GE, GH, GM, HR, HU, ID, IL, IN, IS, JP, KE, KG, KP, KR, KZ, LC, LK, LR, LS, LT, LU, LV, MA, MD, MG, MK, MN, MW, MX, NO, NZ, PL, PT, RO, RU, SD, SE, SG, SI, SK, SL, TJ, TM, TR, TT, TZ, UA, UG, UZ, VN, YU, ZA, ZW.
- (25) Filing Language: **English**
- (26) Publication Language: **English**
- (30) Priority Data:
60/128,122 7 April 1999 (07.04.1999) **US** (84) Designated States (*regional*): ARIPO patent (GH, GM, KE, LS, MW, SD, SL, SZ, TZ, UG, ZW), Eurasian patent (AM, AZ, BY, KG, KZ, MD, RU, TJ, TM), European patent (AT, BE, CH, CY, DE, DK, ES, FI, FR, GB, GR, IE, IT, LU, MC, NL, PT, SE), OAPI patent (BF, BJ, CF, CG, CI, CM, GA, GN, GW, ML, MR, NE, SN, TD, TG).
- (71) Applicant: **VISX, INC.** [US/US]; 3400 Central Expressway, Santa Clara, CA 95080 (US).
- (72) Inventors: **CLAPHAM, Terrance, N.**; 14854 Lakefront Drive, Jamestown, CA 95327 (US). **COWPERTH-WAITE, Michael**; 2310 Rock Street, #3, Mountain View, CA 94043 (US). **HOFER, Richard, A.**; 1062 North Branciforte Avenue, Santa Cruz, CA 95062 (US). **SCRAMAGLIA, Erik**; 30 Clara Avenue, South San Francisco, CA 94080 (US).
- Published:**
— *With international search report.*
- (88) Date of publication of the international search report:
25 January 2001

[Continued on next page]

(54) Title: **IMPROVED INTERFACE FOR LASER EYE SURGERY**

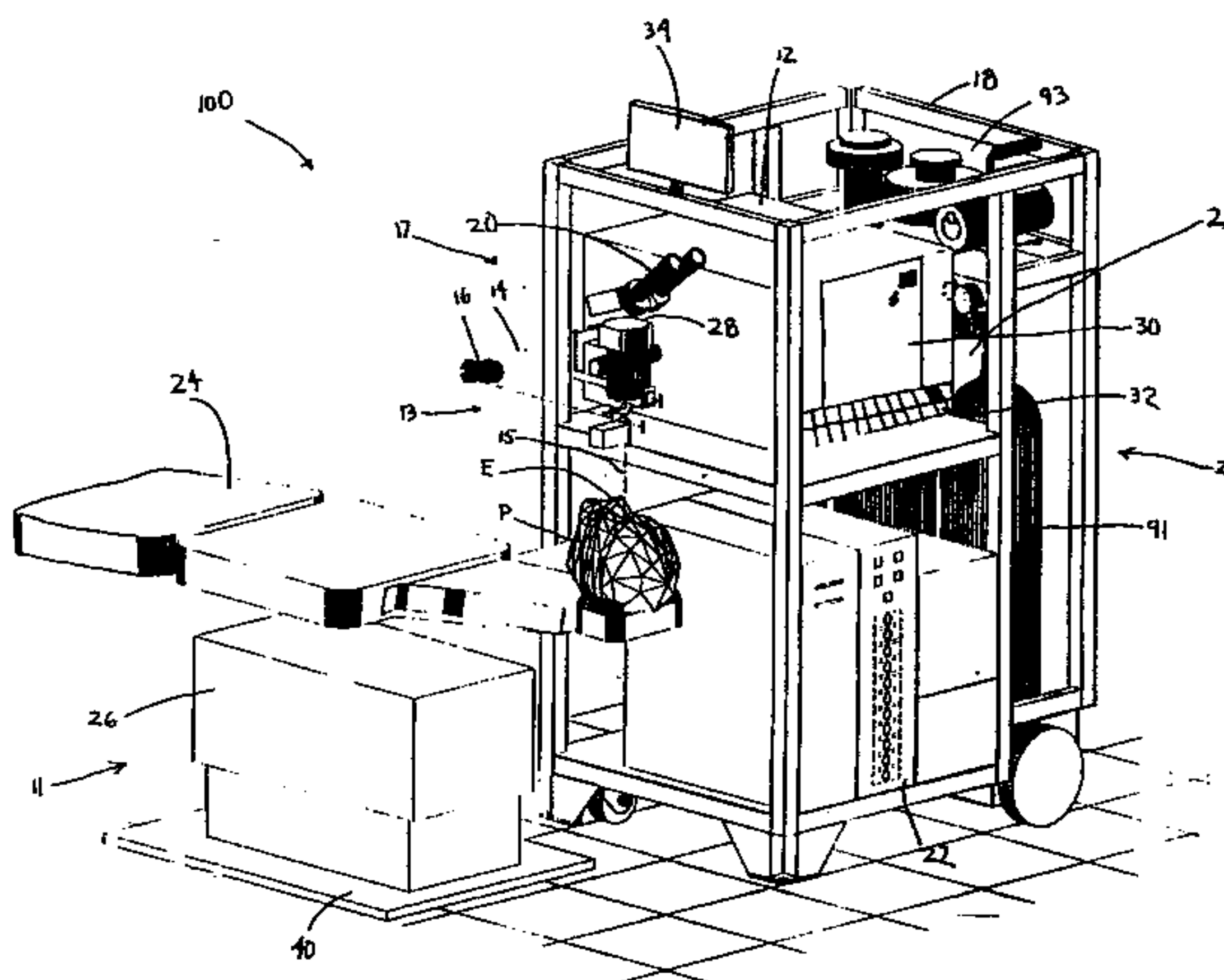

(57) Abstract: This invention is a laser surgery system (100) having a computer control system (22) coupled to a laser subsystem (13), and a patient seat (24). The control system (22) is coupled to the laser through a laser alignment system (17). The control system (22) can be coupled to the patient seat (24) through a patient alignment system (11). The control system (22) sends a nominal position signal to move the patient seat (24), laser subsystem (13), or both so that the patient's first eye is moved into substantial alignment with the laser beam axis. The control system (22) can send a second nominal signal to move the patient's second eye into substantial alignment with the laser beam axis. The control system (22) can optionally comprise both an operator display (23), and an assistant display (34). The assistant display (34) provides real time information to an assistant positioned at an assistant station adjacent the patient seat. The control system (22) can be programmed to display edit fields with different colors to provide an obvious indication of the refractive information of the eye. The control system (22) can comprise an operator input for providing a predetermined secondary ablative treatment. If it is determined that the first ablative treatment did not completely remove the epithelial layer from a target region, the operator actuates the operator input to deliver the secondary ablative treatment.

WO 00/59402 A3

IMPROVED INTERFACE FOR LASER EYE SURGERY

5

BACKGROUND OF THE INVENTION

The present invention relates generally to methods, systems and devices for performing corrective eye surgery. More particularly, the present invention relates to improved computer and laser system interface methods, computer interface programs, and operator system interfaces. The present invention is particularly useful for enhancing the speed, ease, safety, and efficacy of laser eye surgical procedures such as photorefractive keratectomy (PRK), laser in situ keratomileusis (LASIK), and the like.

10

Laser eye procedures typically employ ultraviolet or infrared lasers to remove a microscopic layer of stromal tissue from the cornea to alter its refractive power. Excimer lasers (i.e. ultraviolet laser), such as the VISX STAR™ or STAR S2™ laser system, use argon and fluorine gas to create a non-thermal laser light to break molecular bonds, in a process known as photoablation. Ultraviolet laser ablation results in the photodecomposition of the corneal tissue, but generally does not cause significant thermal damage to adjacent and underlying tissues of the eye. The photoablation removes stromal tissue to change the contour of the cornea to correct myopia (near-sightedness), hyperopia (far-sightedness), and astigmatism.

15

20

In general, existing laser eye surgery systems have included an operator interface for use by the laser system operator in setting-up, controlling, monitoring, and generally directing the laser treatment of the patient's eyes. The safety and efficacy of a photorefractive procedure depends in part on the operator's ability to interact with the laser control system using the operator interface. The costs of each surgical procedure are significantly affected by any unnecessary time delays in setting-up or directing the

25

procedure. Unfortunately, existing operator interfaces are less than ideal in a number of aspects.

The photoablation of corneal tissues benefits from precise alignment between the eye and a therapeutic laser. Known laser eye surgical alignment systems typically have a patient seat or bed with the patient seated, lying down, or reclined in a supine position. To align the patient with the laser beam, the operator must manually adjust the seat or bed into alignment with the laser. Additionally, because the seat or bed often has limited speeds and/or ranges of motion the alignment procedure can be quite time consuming – especially when both eyes are to be treated.

Known operator interface display systems also suffer from a variety of additional disadvantages. For example, it may not always be as clear as would be desirable what type of refractive error and /or correction is represented on a controller display. Specifically, hyperopia and myopia designate alternative refractive errors which are opposite in nature, but it may not always be clear whether a negative value in a hyperopic display field designates a myopic characteristic or correction or a hyperopic characteristic or correction. An error introduced at this point would result in the patient's refractive error being doubled instead of corrected.

Laser ablation of the epithelial layer, an outer layer of the eye, is often performed before the re-sculpting ablation begins. While these epithelial ablations are now controlled from the operator interface, it can be time consuming to reconfigure the system if the epithelial layer is not completely removed from with the initial laser ablation treatment. Finally, known laser refractive surgery systems do not always provide sufficient information to everyone involved in the procedure. In addition to the system operator, the patient and assistant might benefit from procedure and/or system information which is currently directed only to the operator. These limitations detract from the speed, safety, and comfort of known refractive surgical techniques.

For these reasons, it is desired to provide an improved interface for laser eye surgery. In particular, it is desired to have a system capable of automatically aligning the patient's eye with the laser. Furthermore, it would be desirable to have a system which quickly and automatically aligns the patient's second eye after the first eye has been treated. It is also desired to have a system interface which would allow the operator to easily determine the refractive characteristics that have been entered. It would further be desirable to provide a system in which the assistant can view system information

64157-615

3

regarding the procedure, while still being near the patient. It would further be desirable if such a system could easily control the complete ablation of the target portion of the epithelial layer. At least some of these objectives will be met by the
5 system and method of the present invention described hereinafter and in the claims.

SUMMARY OF THE INVENTION

The present invention generally provides improved laser eye surgery devices, systems, and methods. The invention
10 generally enhances laser eye treatment by using methods and interfaces which increase treatment efficiency and provide improved system features.

In one aspect, the present invention provides a laser refractive system comprising: a laser comprising laser delivery
15 optics, the laser produces a laser beam having a longitudinal axis; a moveable patient seat contoured to support a patient in a patient position so that first and second eyes of the patient are near first and second nominal optical axes, respectively; and a patient alignment system coupling the seat to the laser, the
20 patient alignment system configured to automatically move at least one of the patient seat or the laser delivery optics in response to a nominal position signal so that the longitudinal axis of the laser beam is aligned with the first nominal optical axis.

In another aspect, the present invention provides a
25 method of positioning a patient for refractive eye surgery, the patient having first and second eyes, the method comprising: supporting the patient on a patient seat, the patient seat being contoured so as to substantially align first and second eyes of the patient relative to the seat; commanding a control system to
30 automatically positioning the patient in a first nominal position by

64157-615

3a

inputting a nominal seat position signal, in the first nominal position the patient's first eye being substantially aligned with a laser beam axis; and automatically moving the patient to a second nominal position in response to another nominal seat position signal, in the second nominal position, the patient's second eye being substantially aligned with the laser beam axis.

In another aspect, the present invention provides a method of aligning a patient for laser eye surgery, the method comprising: placing a seat in a patient loading position; and activating a control system by inputting a nominal seat position signal, the control system automatically moving the seat to a first nominal position in response to the nominal position signal, wherein contouring of the seat in the first nominal position substantially aligns a patient's eye with a laser beam longitudinal axis.

In another aspect, the present invention provides a laser eye surgery system, the system comprising: a laser producing a laser beam; a patient seat positioned adjacent the laser; an assistant station adjacent the patient seat; a control system coupled to the laser, the control system having laser operation controls and an operator display displaying information about a treatment; and an assistant display coupled to the control system, wherein the assistant display is viewable from the assistant station adjacent the patient seat so that an assistant can monitor the treatment from the assistant station.

In another aspect, the present invention provides a method of providing treatment information from a laser eye

64157-615

3b

procedure to an operator and an assistant adjacent a patient, the method comprising: monitoring treatment information of a laser eye procedure; displaying the treatment information in real-time on an operator display
5 and an assistant display; and aligning the assistant display substantially orthogonal to the operator display, wherein the assistant adjacent the patient can view the information displayed on the assistant display.

In another aspect, the present invention provides
10 a laser eye surgery system, the system comprising: a laser system producing a laser beam; and a computer control station having an operator interface and a control system coupled to the laser system, the control station monitoring and controlling the laser system, wherein the operator
15 interface is configured to display a first font color with fields displaying numeric myopic refractive information and a second font color with fields displaying numeric hyperopic refractive information, the second color being different than the first color so as to differentiate myopic
20 refractive information from hyperopic refractive information.

In another aspect, the present invention provides a method of displaying refractive information, the method comprising: displaying refractive information of an eye on
25 a field in a computer display; providing a first background color for the field if the field is displaying myopic refractive information; and providing a second background color for the field if the field is displaying hyperopic refractive information.

30 In another aspect, the present invention provides a system for removing an epithelial layer from a target region in a cornea during photorefractive surgery, the

64157-615

3c

system comprising: a laser which produces a tissue-ablative beam; a control system coupled to the laser, the control system being adapted to monitor and control the tissue-ablative treatment so that the laser provides an initial
5 epithelial removal ablative treatment and a refraction altering resculpting ablative treatment; and an operator input coupled to the control system, wherein actuation of the operator input causes the control system to actuate the laser to deliver an incremental epithelial ablative
10 treatment, wherein the control system is configured to limit the number of actuations of the operator input to limit a delivery of the incremental epithelial ablative treatment.

In another aspect, the present invention provides a system for removing an epithelial layer from a target
15 region in a cornea, the system comprising: a laser which produces a tissue-ablative beam, wherein the laser is capable of providing a first ablative treatment and a secondary ablative treatment that has a lower energy than the first ablative treatment; a control system coupled to
20 the laser, the control system being adapted to monitor and control the ablative treatments; and a first and second operator input coupled to the control system, wherein actuation of the first operator input actuates the laser to deliver the first ablative treatment and the second operator
25 input actuates the laser to deliver the secondary ablative treatment.

64157-615

3d

10 In another aspect, the present invention provides a laser refractive surgery
system having a laser that produces a laser beam. The laser defines a longitudinal axis
along the path of the laser beam. A patient seat is movable along at least the X and Y
horizontal directions. A control system is coupled to the patient seat and laser and
automatically positions the seat at a nominal position. At the nominal position, the seat
15 substantially aligns a patient's first eye with the laser axis. In a particular embodiment,
the control system can be adapted to automatically substantially align a second eye with
the laser axis.

 In another aspect, the present invention provides a laser refractive system
having a laser which produces a laser beam that defines a longitudinal axis. A patient
20 seat or bed is contoured to support a patient in a patient position so that first and second
eyes of the patient are near first and second nominal axes, respectively. A seat alignment
system couples the seat to the laser. The patient alignment system moves the seat, the
laser, or both, in response to a nominal position signal so that the beam axis is aligned
with the first optical axis.

25 In yet another aspect, the present invention provides a method for
positioning a patient for refractive eye surgery. The method includes the steps of
automatically positioning a patient in a first nominal position. In the first nominal
position, the patient's first eye is substantially aligned with a laser. The patient is then
automatically positioned to a second nominal position. In the second nominal position,
30 the patient's second eye is substantially aligned with the laser. In most embodiments, the
patient is automatically moved to the second nominal position after the first eye has been
treated.

In another aspect, the present invention provides a method for aligning a patient for laser surgery. The method comprises placing a seat in a patient loading position. A control system is activated to move the seat to a first nominal position in which the patient's eye is substantially aligned with a laser beam axis.

5 In a further aspect, the present invention provides a laser eye surgery system. The system includes a laser for producing a laser beam. A patient seat or bed is positioned adjacent the laser. A control system is coupled to the laser. The control system has laser operation controls and displays information about the treatment. An assistant display is coupled to the control system, wherein the monitor is viewable from
10 adjacent the patient seat or bed so an assistant can monitor the treatment from the assistant station.

In another aspect, the present invention provides a method of providing treatment information of a laser eye procedure to an operator and an assistant adjacent a patient. The method comprises monitoring treatment information of a laser eye
15 procedure. The treatment information is displayed in real-time on a computer control system and an assistant display. The assistant display screen is aligned substantially orthogonal to the computer control system so the assistant adjacent the patient can view the information displayed on the assistant display.

In yet another aspect, the present invention provides a method for
20 performing corrective eye treatment. The method includes the step of directing a laser beam at a corneal region of an eye of a patient. Information about the treatment is displayed to the operator in real-time on a control station display. Information about the treatment is also displayed to an assistant in real-time on an assistant display, such that the assistant can view the information while adjacent the patient.

25 In a further aspect, the present invention provides a laser eye surgery system having a laser system for producing a laser beam for refractive surgery on a cornea. A computer control station, having an operator interface and control system, is coupled to the laser system to monitor and control the laser system. Typically, the computer control system is adapted to display on the operator interface a first color with
30 fields displaying myopic refractive information and a second color with fields having hyperopic refractive information. The first color and second color are preferably different colors.

In another aspect, the present invention provides a method of displaying refractive information. The method includes the step displaying refractive information on an edit field. A first background color is provided for the edit fields displaying myopic refractive information. A second background color is provided for the edit fields displaying hyperopic refractive information.

In yet another aspect, the present invention provides a system for removing an epithelial layer from a target region in a cornea during photorefractive surgery. The system includes a laser which produces a tissue-ablative beam. The laser provides an initial uniform epithelial ablative treatment over the region and a refraction altering re-sculpting ablative treatment. A control system that is adapted to monitor and control the ablative treatments is coupled to the laser. An operator input is coupled to the control system, such that upon actuation of the operator input, the control system actuates the laser to provide an incremental epithelial ablative treatment.

In a further aspect, the present invention provides a system for removing an epithelial layer from a target region in a cornea. The system includes a laser which provides a first ablative treatment and a secondary ablative treatment. A control system is coupled to the laser and is adapted to monitor and control the tissue ablative treatments. An operator input for providing a secondary ablative treatment is coupled to the control system. Upon actuation of the operator input, the laser provides a secondary ablative treatment. In a preferred embodiment, the operator input comprises a button mounted to the control system. Actuation of the button can deliver a pre-determined amount of the tissue ablative beam.

In yet another aspect, the present invention provides a method for removing an epithelial layer from over a stromal layer in a cornea. The method includes irradiating a target region of the epithelial layer with a first amount of ablative radiation. If it is determined that the first amount of ablative radiation did not completely remove the epithelial layer from the target region, the target region of the epithelial layer is irradiated with a pre-determined secondary amount of ablative radiation. In a preferred embodiment, a button is depressed to deliver the secondary amount of ablative radiation.

These and other aspects of the invention will be further evident from the attached drawings and description of the invention.

BRIEF DESCRIPTION OF THE DRAWINGS

Figure 1 illustrates a simplified cross-sectional view of a human eye;

Figure 2 illustrates a cross-sectional view of the five layers of the cornea;

5 Figure 3 illustrates a perspective view of a laser eye surgery system in accordance with the principles of the present invention;

Figure 4 illustrates a plan view of the system of Fig. 1 showing the relative orientation of the assistant display and the operator display;

Figure 4A illustrates an embodiment of the assistant display;

Figure 4B illustrates another embodiment of the assistant display;

10 Figure 5A illustrates an interface display having a first background color for a screen displaying myopic refractive information;

Figure 5B illustrates an interface display having a second background color for a screen displaying hyperopic refractive information;

15 Figure 6 illustrates a control station having a physical button and a button actuatable by a cursor;

Figure 7 shows a touch screen having a sample treatment screen with a "deeper button" to incrementally ablate corneal tissue to complete removal of the epithelium in preparation for a re-sculpting procedure;

20 Figure 7A illustrates a joystick setup which can control the gross adjustment mechanism and/or the fine adjustment mechanism;

Figure 8A illustrates an embodiment of the contoured patient seat adjustable along the Z-axis;

Figure 8B illustrates an embodiment of the contoured head pillow;

Figure 8C illustrates a headrest control;

25 Figure 8D illustrates a contoured patient seat in a loading position;

Figure 8E illustrates a patient seat in a nominal position, substantially aligned with the laser axis, wherein a patient's first eye is within the range of motion of the laser;

Figure 8F illustrates a laser axis aligned with a patient's first optical axis;

30 Figure 8G illustrates the laser axis in a second nominal position, aligned with a patient's second optical axis;

Figure 9 schematically illustrates an embodiment of the invention;

Figure 10 is a flow chart of the process of aligning a patient with the laser axis;

Figure 11 is a flow chart of the process of ablating the epithelial layer using the deeper button;

5 Figure 11A illustrates a complete epithelial layer in the target region being treated by a first ablative treatment;

Figure 11B illustrates an epithelial layer that was not completely removed by the first ablative treatment, which is being treated by a secondary-ablative treatment; and

10 Figure 12 shows a touch screen having a second sample treatment screen after the epithelial layer of the target region has been removed.

DESCRIPTION OF THE SPECIFIC EMBODIMENTS

The present invention provides systems, methods and interfaces for improving the laser treatment of the eye. More specifically, the systems and interfaces of
15 the present invention are particularly suited for use on the STAR™ and STAR S2™ Excimer Laser System which are commercially available from VISX, Incorporated of Santa Clara, California. Additionally, the systems and interfaces of the present invention are suitable for use with laser systems manufactured by Chiron Vision of Irvine California, Summit Technology of Watertown, Massachusetts, Nidek Co., Ltd. of
20 Gamagori, Japan, Meditec of Heroldsberg, Germany, LaserSight of Orlando, Florida, Autonomous Technologies Corporation of Orlando, Florida, and the like. The systems may be programmed to perform the methods of the present invention by providing a computer program in the form of a tangible medium comprising computer readable code setting further the methods described in more detail below.

25 Fig. 1 illustrates a simplified view of an eye. The cornea 69 covers the pupil and provides the focusing power to the eye. The pupil 63 is located behind the cornea and controls the amount of light entering the eye. The lens 67 is a clear structure located behind the cornea and provides fine-tuning for focusing. The retina 64 transmits the images to the brain. Myopia occurs when the eye is too long for the cornea's
30 curvature. Light rays entering the eye do not come to a sharp focus on the retina, but instead focus further forward of the retina. In contrast, hyperopia occurs when the eye is too short for the cornea's curvature and light rays entering the eye focus behind the retina.

64157-615

8

Specifically, as shown in Fig. 2, the cornea is composed of five layers of tissue. The cornea is comprised of the epithelial layer 70, the lamina limitans anterior (also known as Bowman's layer 72), the stromal layer 74, lamina limitans posterior (also known as Descemet's layer 76), and the endothelium 78. The outermost layer, the epithelial layer 70 is approximately 50 μm thick. For patients undergoing a photorefractive keratectomy (PRK), the epithelial layer of a target region is removed or displaced from over the pupil before the stromal layer 74 is shaped to correct the contour of the cornea.

Fig. 3 illustrates a laser surgery system embodiment in accordance with the principles of the invention. Laser eye surgery system 100 is designed for performing corrective laser surgery with an excimer laser to reshape the surface of the cornea to correct refractive vision errors. In general, the surgery system of the present invention includes an operator control station 21 having a computer control system 22 and laser operation controls 23. The computer control system 22 generally comprises a conventional PC computer coupled to a keyboard 32, an operator display 30, an assistant display 34, and standard computer input and subsystem components (e.g., flexible and hard disk drives, CD-ROM, an internet connection, modem, memory boards and the like). Various input devices, such as a touch screen, joystick, mouse, foot pedals, and the like, can be used to input information or send control signals to the control system. Such input devices will often be used to download and execute a computer code from a tangible storage media, such as a computer program in the form of a computer-readable floppy disk, a CD-ROM, a cartridge, a data tape, or other conventional medium, to embody the methods of the present invention. Additionally, the computer 22 can be programmed using any conventional programming technique to encode the methods for the present inventions, as described in more detail below. Further details of suitable system for performing a laser ablation procedure can be found in commonly assigned U.S. Patent Nos. 4,665,913, 4,669,466, 4,732,148, 4,770,172, 4,773,414, 5,207,668, 5,108,388, 5,735,843, 5,711,762, 5,219,343, 5,646,791 and 5,163,934.

The computer control system 22 is typically mounted to a base frame 18 and is preferably coupled to a laser subsystem 13 through a laser alignment system 17. Additionally, the computer control system is coupled to a patient seat 24 through a patient

alignment system 11. As will be described more fully below, the patient seat 24, laser delivery optics 16, or both, can be moved in response to a control signal to align the patient's eye E with a laser beam axis 15.

The operator interface display 23 and the assistant display 34 are typically conventional computer monitors. However, the operator display and assistant display can be a touch screen, a computer controlled timer, an alphanumeric light emitting diode (LED), liquid crystal display, or the like. The assistant display 34 is used to provide real-time visual indication to the assistant or observer of the remaining treatment time or other information associated with the laser treatment. Preferably, the assistant display is a dedicated monitor mounted on the arm supporting a laser delivery optics 16 or base frame 18 (Fig. 4). However, as shown in Fig. 3, the assistant display can be mounted anywhere that allows the assistant or observer to view the information shown on the assistant display while adjacent the patient.

As illustrated in Fig. 4, the assistant display 34 is typically mounted on arm 94 and aligned orthogonal to the operator interface 30. Preferably, the assistant display faces toward the patient seat 24, where the assistant station 92 is typically located. The assistant display typically shows the remaining time in characters which are approximately 20 mm in height. The assistant display preferably has at least a +/- 50° viewing angle 99, but the viewing angle will vary depending on the type of display used and the placement of the assistant display. In some embodiments, the assistant display is rotatable and/or movable to a different viewing position. A plurality of assistant displays can be coupled to the computer to allow multiple observers to view the treatment. For example as illustrated in Figs. 4A and 4B, a first assistant display can be programmed to show the time remaining until completion of the procedure 95, while a second assistant display can be programmed to show a virtual reticle 96, the refractive information 98, or current depth of the ablation (not shown). It should be appreciated that the control system can be configured to display a variety of information on the assistant display 34 and the operator display 23. The displays can display the same information, different information or any combination thereof.

One embodiment of the assistant display employs a method of decoding Binary Code Decimal (BCD) into Seven-Segment Code. The decoder is a combinational circuit that accepts a decimal digit in BCD and generates the outputs for selection of segments that display the decimal digit. Each digit of the display is formed from seven

segments (a, b, c, d, e, f, g), each consisting of one light emitting diode (LED) that can be illuminated by digital signals. The numeric designation chosen to represent the decimal digits is shown in Fig. 4A. The decoding is performed inside a programmed logic device (PLD).

5 Referring now to Figs. 5A and 5B, the computer control system 22 can be programmed to contain edit fields on the operator interface display 30 for entering and/or displaying refractive information of the patient's eye. The control system can be programmed to display the edit fields with different colors to provide a display which provides an obvious indication of the refractive information of the eye. The edit fields of
10 the system preferably change color to reflect the change in sign (negative or positive) of the values that are displayed in the edit field. Edit fields containing myopic refractive values can have a first color 50, while edit fields containing hyperopic refractive information can have a second color 52. Because myopic refractive information has traditionally been associated with the color red, edit fields having myopic or negative
15 refractive information preferably have a red background. Conversely, edit fields having hyperopic or positive refractive information preferably have a black background. However, it is contemplated that any combination of background colors can be used to display the refractive information. Additionally, instead of having a different background colors, the control system can be programmed to provide different font colors. In most
20 cases, the refractive information will still have the preceding "+" or "-" in addition to the different colored backgrounds or fonts.

The combination of the different colors and leading sign allows the operator to easily determine, at a glance, whether the refractive information is myopic or hyperopic, and will allow the operator to alter or stop the treatment if desired. For
25 example, as illustrated in Fig. 5A, for an eye having mild myopia with a correction of -2.50 diopters the background on an operator display 30 will be a first color 50. As shown in Fig. 5B, if the refractive property of the eye is corrected to +0.50 diopters, the background will change to a second color 52.

Another aspect of the present invention is the addition of an operator input
30 which provides a pre-determined secondary ablative treatment of the epithelial layer. The improved operator interface preferably supports the "no-touch PRK," which removes the epithelial layer with a laser instead of a mechanical scrubber or spatula. In order to assure uniform removal of the epithelial layer over the entire target region, the ablative radiation

64157-615

11

is typically patterned or adjusted by the control system, as described in U.S. Patent No. 6,068,625. However, even with a patterned laser, the first ablative treatment often does not completely remove the epithelial layer from the target region.

5 The control system can be programmed to deliver a pre-determined first amount of ablative energy and a pre-determined secondary ablative treatment. In most embodiments, the secondary ablative treatment is an incremental or smaller dosage of the first ablative treatment. Preferably, the secondary ablative treatment is delivered through
10 actuation of a "deeper" button at the control station 21. As illustrated in Figs. 6 and 7, the button can be a physical button 86, an icon 88 actuatable by a computer cursor 87, a button 84 on a touch screen, or the like. As will be described more fully below, actuation of the deeper button delivers a secondary ablative treatment without requiring the physician to reprogram the laser. Once it is determined that the epithelial layer has been completely ablated from the target region, the laser can proceed to the shaping of the
15 stromal layer.

 Referring again to Fig. 3, the control system 22 is typically coupled to the laser subsystem 13 to control the treatment of the cornea. Laser 12 is optically coupled to laser delivery optics 16, which direct laser beam 14 along a laser axis 15 to an eye of a patient P. Laser 12 can produce a single beam or multiple scanning beams of ablative
20 radiation. A delivery optics support structure (not shown) extends from a base frame 18 to support the laser. Laser 12 generally comprises an excimer laser, ideally comprising an argon-fluorine laser producing pulses of laser light having a wavelength of approximately 193 nm. An excimer laser is the illustrative source of an ablating beam, however, other lasers, such as solid state lasers, are equally suitable in the present invention. The laser
25 system may include a variety of solid state lasers, including frequency multiplied solid state lasers such as flash-lamp and diode pumped solid state lasers. Exemplary solid state lasers include UV solid state lasers (approximately 193-215 nm) such as those disclosed in U.S. Patent Nos. 5,144,630, 5,742,626, Borsuztky et al., "Tunable UV Radiation at Short Wavelengths (188-240 nm) Generated by Sum Frequency Mixing in Lithium
30 Borate", Appl. Phys. 61:529-532 (1995).

Such lasers include, but are not limited to, alternative lasers providing ultraviolet radiation, for example, solid state lasers, including frequency multiplied solid state lasers such as flash-lamp and diode pumped solid state lasers,

64157-615

12

including UV solid state lasers (approximately 193-215 nm) such as those disclosed in US Patent Nos. 5,144,630, 5,742,626, Borsuziky et al., "Tunable UV Radiation at Short Wavelengths (188-240 nm) generated by Sum Frequency Mixing in Lithium Borate," Appl. Phys. 61:529-532 (1995).

5 Laser 12 will preferably be designed to provide feedback stabilized fluence of 160 mJoules/cm² at the patient's eye, as delivered via delivery optics. The system may be used with alternative sources of radiation of any wavelength, particularly those adapted to controllably photo-decompose the corneal tissue without causing significant damage to adjacent and/or underlying tissues of the eye. Laser 12 and delivery optics 16 will
10 generally direct laser beam 14 to the eye of patient P under the direction of a computer 22. Computer control system 22 will generally selectively expose portions of the cornea to laser pulses of laser beam 14 to remove the epithelial layer of the target region and to effect re-sculpting of the cornea and later the refractive characteristics of the eye. A microscope 20 mounted on the delivery optic support structure near the control system
15 and above the patient's head P, allows the operator to monitor the progress of the treatment. Other ancillary components of the laser subsystem 13 include a patient eye retention system (not shown), an ablation effluent evacuator/filter 91, as well as the gas delivery system 93.

Laser beam 14 may be tailored to produce the desired re-sculpting using
20 one or more variable apertures (such as a variable iris and variable width slit as described in U.S. Patent Nos. 5,713,892, 5,711,762 and 5,735,843),
by varying the size and offset of the laser spot from the axis of the eye (as described in U.S. Patent No. 5,683,379, and also described in U.S. Patent Serial No. 6,203,539), by scanning the laser beam
25 over the surface of the eye and controlling the number pulses and/or dwell time (as described by U.S. Patent No. 4,665,913),
using masks in the optical path of laser beam 14 which ablate to varying the profile of the beam incident on the cornea (as described by U.S. Patent No. 5,807,379), or the like. The computer programs and control
30 methodology for each of these re-sculpting techniques is well described in the patent literature. Additional optical components may also be included in the optical path of laser

64157-615

13

beam 14, such as integrators to spatially and/or temporally control the distribution of energy within the laser beam (as described in U.S. Patent No. 5,646,791), and the like.

Referring again to Fig. 3, computer control system 22 is preferably
5 coupled to both a patient alignment system 11 and a laser alignment system 17 to align the laser beam axis with a first optical axis of a first eye. The head of patient P can be firmly supported on and preferably restrained by a contoured patient seat 24 to support a patient in position so that first and second eyes of the patient are near first and second nominal optical axes.

10 Positioning of the eye E relative to the laser delivery optics is generally effected by movement of the patient seat 24 into substantial alignment with the laser beam axis 15. The patient is generally laying down or reclined in a supine position. However, in alternative embodiments the patient is oriented in an upright seated position (as described in U.S. Patent No. 5,795,351).

15 Patient alignment system 11 preferably comprises a gross adjustment mechanism 26 having an activating motors to move the seat or bed in the X, Y and Z direction. The gross adjustment mechanism structurally couples the seat to the laser and can be actuated by a signal from the control system or manually actuated by a joystick 25
20 to move the patient seat along at least the X and Y horizontal directions to align the patient's eye with the laser beam axis (Fig. 7A).

The optical system and/or the laser delivery optics 16 can be moved with a fine adjustment mechanism 28 of the laser alignment system 17 to align the laser beam axis 15 with the first optical axis 80 while the patient is supported on the patient seat. If
25 the laser delivery optics are to be moved, the objective lens of the microscope will preferably remain affixed relative to at least a portion of the laser optical train adjacent the eye so as to maintain alignment between the microscope field of view and the laser treatment site, as described in U.S. Patent No. 6,251,101, filed June 26, 1998. The

30 fine adjustment mechanism 28 can be manually actuated or computer actuated to finely move the laser delivery system to fully align the eye with the laser beam (Fig. 3). Typically, the fine adjustment mechanism is comprised of an activating motor which can move the laser delivery optics in the X, Y, and Z direction. Typically, the fine adjustment

mechanism uses the same joystick and moves the laser optics at a slower speed. In alternative embodiments, the fine adjustment mechanism can be coupled to the patient seat to finely align the patient's eye with the laser by making minute adjustments to the seat. Preferably, when the fine adjustment is coupled to the seat, the same joystick and activating motor are used, but the motor is adapted to move at a lower speed.

Fig. 7A illustrates a typical joystick setup. Preferably, the joystick 25 is located at the operator's station 21 and adjacent the microscope 20. The joystick adjusts the position and orientation of the patient chair and/or the laser optics. Typically, movement of the joystick is progressive, i.e., the farther the joystick is moved from the rest position, the faster the chair moves. In a preferred setup, movement of the joystick to the left causes the patient chair to move to the right, and vice versa. Movement of the joystick forward moves the patient toward the operator, and vice versa. Turning of the joystick handle clockwise can move the patient chair upward and vice versa. However, alternative setups are equally suitable in the present invention. For example, an alternative setup can include moving the joystick to the left to move the patient to the left and moving the joystick forward to move the patient away from the operator.

Figs. 8A-8G illustrate a preferred embodiment of the movable patient seat. As shown in Fig. 8A, the patient seat 24 is mounted to base 40 through a gross adjustment mechanism 26. A chair release pedal 53 is typically located at the base. To lock the chair, the operator can press the right side of the pedal. This can prevent the chair from pivoting outward and can prevent the chair main body from being raised. To unlock the chair, the operator can press the left side of the pedal.

The patient seat or bed typically comprises a head rest 42, a main body 44, and a lower support 46. The head of patient P will be firmly supported by, and preferably restrained by a contoured head rest 97. Preferably, the contoured head rest comprises an adjustable vacuum pillow or cushion which conforms to the patient's head to stabilize the patient's head in position. The pillow can be adjusted for comfort, angle, support and stability. As shown in Fig. 8B, the vacuum pillow 97 is positioned around and under the patient's head P to support the patient. After the patient is placed on the pillow, the operator connects a vacuum pillow suction tubing to the pillow and a suction port. The operator turns on a suction pump with a pillow suction button (not shown), and after about five seconds, the pillow hardens and conforms to the patient's head.

As shown in Fig. 8C, chair headrest controls 55 are preferably located underneath the chair headrest to further align the patient's head. Chair headrest controls typically comprise at least two knobs for adjusting the headrest. The head-tilt knob 57, controls the angle of the patient's head. Typically, an operator can turn the knob
5 clockwise to angle the top of the patient's head upward. The neck-tilt knob 59 controls the angle of the patient's neck. Turning of the knob clockwise angles the patient's neck upward.

As shown in Fig. 8A, gross adjustment mechanism 26 is coupled to the control system and is adapted to move the patient seat in at least the X and Y horizontal
10 directions and rotate the seat about at least one of the X, Y, and Z axes. In alternative embodiments, the patient seat is movable in both the horizontal and vertical directions 79 (X, Y, and Z) to axially and laterally align the first optical axis with the laser beam axis (Fig. 8A).

The control system will typically be programmed to automatically move
15 patient seat 24 from a loading position (Fig. 8D) to a first nominal position (Fig 8E). Preferably, the first nominal position places the seat in a nominal "X", nominal "Y", and a nominal "Z" position such that the seat is generally near the center of the X, Y, and Z directions and the patient's first optical axis 80 is substantially aligned with the laser beam axis 15. However, the first optical axis will not be always be completely aligned
20 with the laser beam axis 15. As long as the nominal position is within the range of motion 65 of the laser alignment system, the first optical axis 80 can be properly aligned with the laser axis by making adjustments to the fine adjustment mechanism. If fine adjustments are required, the operator can manually adjust the fine adjustment mechanism by actuating the joystick to align the patient's eye with the laser. The operator can
25 manually view the alignment of the laser through the operator interface display 30 or the microscope before the patient is on the seat or bed. Alternatively, the computer control system can be programmed to automatically actuate the fine adjustment mechanism to align the laser beam axis with the first optical axis of the patient's eye. Fig. 8F illustrates the laser axis completely aligned with a patient's first eye.

30 As shown in Fig. 8G, the control system can also be programmed to automatically move to a second nominal position to align a second optical axis 82 (i.e. patient's second eye) with the laser beam axis 15. The control system can be programmed to automatically align the second optical axis with the laser beam axis

immediately after treatment of the first eye or to directly align the second optical axis with the laser beam axis. For example, the control system will often be programmed to have the first nominal position align over the patient's right eye. However, in situations where only the left eye is treated, the control system can be programmed in various ways.

5 Alignment can be accomplished by initially moving to the first nominal position (alignment with right eye) and then immediately moving to the second nominal position (alignment with the left eye). Alternatively, the system can be programmed to move directly to the second nominal position. Preferably, the control system can move the patient seat or laser optics to a second nominal position so that the patient's second eye is
10 completely aligned with the laser beam axis. If the eye is not completely aligned with the laser, the operator should not be required to manually realign the patient seat with the gross adjustment mechanism, as the second position will typically be in the range of motion of the fine adjustment mechanism. If adjustments are required, the operator can manually adjust the laser optics, manipulate a computer input device (i.e. joystick) to
15 align the laser axis with the patient's second eye, or allow the control system to automatically align the laser axis with the second optical axis.

Referring now to Fig. 9, the computer 22 is coupled to the laser eye system 100 to control the laser eye treatment. Using input devices 33, the operator can manually input the number of laser pulses, the desired patterning of the laser, and the like. The
20 information will generally be shown on the operator interface display 30 and/or the assistant display 34. Typically, a laser monitoring system 21 monitors the eye during the treatment and sends the information to the computer for display on the operator display and/or the assistant display. The laser monitoring system 21 can include of a video camera, sensors, seat position sensors, beam position sensors, or the like. The computer
25 control system will preferably be programmed to display the refractive information, the remaining time, a virtual reticle, and the like.

The operation of a typical procedure will now be described in detail. As illustrated in Figs. 9 and 10, the patient is initially seated in the patient seat 24 (Step 101). Preferably, the chair is unlocked using the chair release pedal, and the chair can be
30 allowed to rotate outward, upward, or away from the laser. Typically, the chair is moved to a sitting position by pressing a switch on the chair headrest. The chair can then be moved to a reclining position by pressing a switch on the headrest. Using a joystick, the chair can be lowered to its lowest position to allow the patient to be moved beneath the

laser. At some point prior to aligning the patient's eye with the laser, the patient's head can be stabilized using a vacuum pillow, as described above.

Next, the operator can actuate the computer control system (Step 102) to send a nominal position control signal to the laser alignment system 17, the patient alignment system 11, or both, to align the patient in a first nominal position (Step 104). Preferably, the operator simply actuates input devices such as a fixed button, a touch screen, or menu selection on the operator display, to move the patient to the first nominal position and align the laser axis with the first optical axis. If the patient's eye is aligned with the laser axis, the operator will proceed to epithelial treatment (Step 108). However, in some situations, the patient will not be completely aligned with the laser axis. Since the patient is within the range of motion of the fine adjustment mechanism, the operator can actuate the control system to send a signal to the fine adjustment mechanism to completely align the laser with the first optical axis (Step 114). Alternatively, the operator can manually align the laser axis with the eye by actuating a joystick. After proper alignment is achieved, the laser can be activated through the laser operation controls 23 to perform the epithelial treatment (Step 116).

If a photorefractive keratectomy (PRK) is performed, the operator can use the laser operation controls to remove the epithelial layer from the target region prior to shaping the stromal layer. As illustrated in Figs. 11 and 11A, a pre-programmed first tissue ablative beam 75, typically a uniform beam, can be delivered over the target region of the epithelial layer 70 (Step 119). If the epithelial layer is completely removed, the operator can proceed to stromal re-sculpting (Step 130). However, as illustrated in Fig. 11B, the first ablative treatment 75 often leaves a portion of the epithelial layer 73 in the target region 71. If it is determined that that the first ablative treatment was inadequate (Step 120), the operator can actuate the deeper button (Step 122). Actuation of the deeper button delivers a pre-determined secondary ablative treatment 77 to remove the remaining epithelial layer 73 from the target region 71 (Step 124). Typically, each secondary-ablative treatment is an incremental or shorter dosage of the first ablative treatment and is typically programmed to remove between 1 μm to 15 μm , and preferably between 5 μm to 10 μm of the epithelial layer. The operator simply presses the deeper button to deliver the secondary ablative treatment. After the delivery of the secondary ablative treatment, the operator can monitor the epithelial layer to determine if the secondary-treatment was

adequate (Step 126). If the treatment was adequate, the operator can proceed to the stromal re-sculpting, to correct the vision errors (Steps 128). However, if the secondary treatment was inadequate, the operator can actuate the deeper button to deliver the pre-programmed secondary ablative energy (Step 122). In a preferred embodiment, the control system can be programmed to limit the amount of secondary-ablative treatment to that of approximately 25 μm . Preferably, this is achieved by limiting the amount of times the deeper button can be actuated. For example, the computer can be programmed to allow the operator to press the deeper button a 3 times (Step 132) before having to manually re-program the laser to remove the remaining epithelial tissue (Step 134). This safety feature can help avoid the inadvertent ablation of the underlying stromal layer.

Some embodiments of the system allow the operator to program the power, patterning of the laser, time of ablation, depth of epithelial tissue to be removed, and the like. For example, if the first ablative treatment removes 35 μm of the epithelial layer, and the operator presses the deeper button and removes 10 μm of the epithelial layer, the operator can program the next ablative energy to ablate between 1-5 μm . Alternatively, the operator can pre-program the deeper button to deliver only 5 μm for every secondary ablative treatment. Moreover, the control system can be programmed to reduce each subsequent secondary ablative treatments. For example, the initial secondary ablative treatment can be programmed to ablate 10 μm of the epithelial layer, the subsequent treatments can be programmed to ablate 5 μm of the epithelial layer, and so forth. Preferably, the control system can monitor the ablation of the epithelial layer and display on the operator display the progress of the ablation.

Once the epithelial layer has been completely removed the operator can proceed to the stromal re-sculpting. Typically, the control system will display a treatment screen having refractive information, treatment time, or the like. A sample treatment screen is shown in Fig. 12.

While the above is a complete description of the preferred embodiments of the invention, various alternatives, modifications, and equivalents may be used. Therefore, the above description should not be taken as limiting the scope of the invention which is defined by the appended claims.

·64157-615

19

CLAIMS:

1. A laser refractive system comprising:

a laser comprising laser delivery optics, the laser produces a laser beam having a longitudinal axis;

5 a moveable patient seat contoured to support a patient in a patient position so that first and second eyes of the patient are near first and second nominal optical axes, respectively; and

10 a patient alignment system coupling the seat to the laser, the patient alignment system configured to automatically move at least one of the patient seat or the laser delivery optics in response to a nominal position signal so that the longitudinal axis of the laser beam is aligned with the first nominal optical axis.

15 2. A system as recited in claim 1, wherein:

the patient seat is moveable along at least X and Y horizontal directions; and

20 the alignment system includes a control system configured to automatically position the patient seat at the first nominal position in the X and Y directions.

25 3. A system as recited in claim 2, the alignment system comprising a fine adjustment mechanism for aligning the longitudinal axis of the laser beam with the patient's first eye, wherein the fine adjustment mechanism moves the seat or the laser delivery optics.

4. A system as recited in claim 3, wherein the fine adjustment mechanism comprises an activating motor, wherein the activating motor is coupled to the patient seat and the control system such that the activating motor moves the

64157-615

20

patient seat in response to a signal from the control system.

5. A system as recited in claim 4, wherein the activating motor is adapted to move the patient seat in response to manual actuation of an input device coupled to the control system.

6. A system as recited in claim 3, wherein the fine adjustment mechanism comprises an activating motor, wherein the activating motor is coupled to the laser delivery optics and the control system, such that the activating motor moves the laser delivery optics in response to a signal from a control system.

7. A system as recited in claim 6, wherein the activating motor is adapted to move the laser delivery optics in response to a signal that is generated from manual actuation of an input device coupled to the control system.

8. A system as recited in claim 2, wherein the alignment system further comprises a gross adjustment mechanism that is independent of a fine adjustment mechanism, wherein the gross adjustment mechanism is configured to be able to align the first nominal optical axis with the laser beam longitudinal axis by moving the patient seat.

9. A system as recited in claim 8, wherein the gross adjustment mechanism comprises an activating motor, such that the activating motor moves the patient seat in response to the nominal position signal from the control system.

10. A system as recited in claim 9, wherein the activating motor is configured to move the seat in response

-64157-615

21

to the nominal position signal that is generated from manual actuation of an input device coupled to the control system.

11. A system as recited in claim 8, wherein the control system is adapted to actuate the gross adjustment mechanism, the fine adjustment mechanism, or both, to automatically align a second eye of the patient with the laser beam longitudinal axis after the patient's first eye has been aligned with the longitudinal axis of the laser beam.
- 10 12. A system as recited in claim 11, wherein the control system aligns the second eye of the patient with the longitudinal axis of the laser beam after the first eye has been treated with the laser.
- 15 13. A system as recited in claim 12, wherein the control system aligns the second eye with the laser axis in response to an input into the control system.
14. A system as recited in claim 2, wherein the first nominal position is near a center of the X and Y horizontal directions.
- 20 15. A system as recited in claim 14 wherein the patient seat is movable along the X, Y, and Z directions, wherein the control system is configured to automatically position the seat at a nominal position of the X, Y, and Z directions, in which the nominal position is near a center
25 of the X, Y, and Z directions.
16. A system as recited in claim 2, further comprising a computer program having a tangible medium and computer-readable code, wherein the control system uses the computer program to automatically align the patient's first eye and

.64157-615

22

the patient's second eye with the longitudinal axis of the laser beam.

17. A method of positioning a patient for refractive eye surgery, the patient having first and second eyes, the
5 method comprising:

supporting the patient on a patient seat, the patient seat being contoured so as to align first and second eyes of the patient relative to the seat;

10 commanding a control system to automatically positioning the patient in a first nominal position by inputting a nominal seat position signal, in the first nominal position the patient's first eye being aligned with a laser beam axis; and

15 automatically moving the patient to a second nominal position in response to another nominal seat position signal, in the second nominal position, the patient's second eye being aligned with the laser beam axis.

18. The method as recited in claim 17, wherein the moving is carried out after the first eye has been treated.

20 19. The method as recited in claim 17 wherein positioning is carried out by moving the patient seat.

20. The method as recited in claim 19, wherein the nominal positions are near a center of the seat's X and Y horizontal directions of movement.

25 21. A method of aligning a patient for laser eye surgery, the method comprising:

placing a seat in a patient loading position; and

-64157-615

23

activating a control system by inputting a nominal seat position signal, the control system automatically moving the seat to a first nominal position in response to the nominal position signal, wherein contouring of the seat
5 in the first nominal position aligns a patient's eye with a laser beam longitudinal axis.

22. The method of claim 21 wherein placing the seat comprises rotating the seat to an upright position.

23. The method of claim 21 further comprising making
10 fine adjustments to at least one of a laser optics or the patient seat to align the patient's eye with the laser beam axis.

24. The method of claim 23 further comprising activating the control system to move the seat to align the patient's other eye with the laser beam longitudinal axis by inputting another nominal seat position signal.

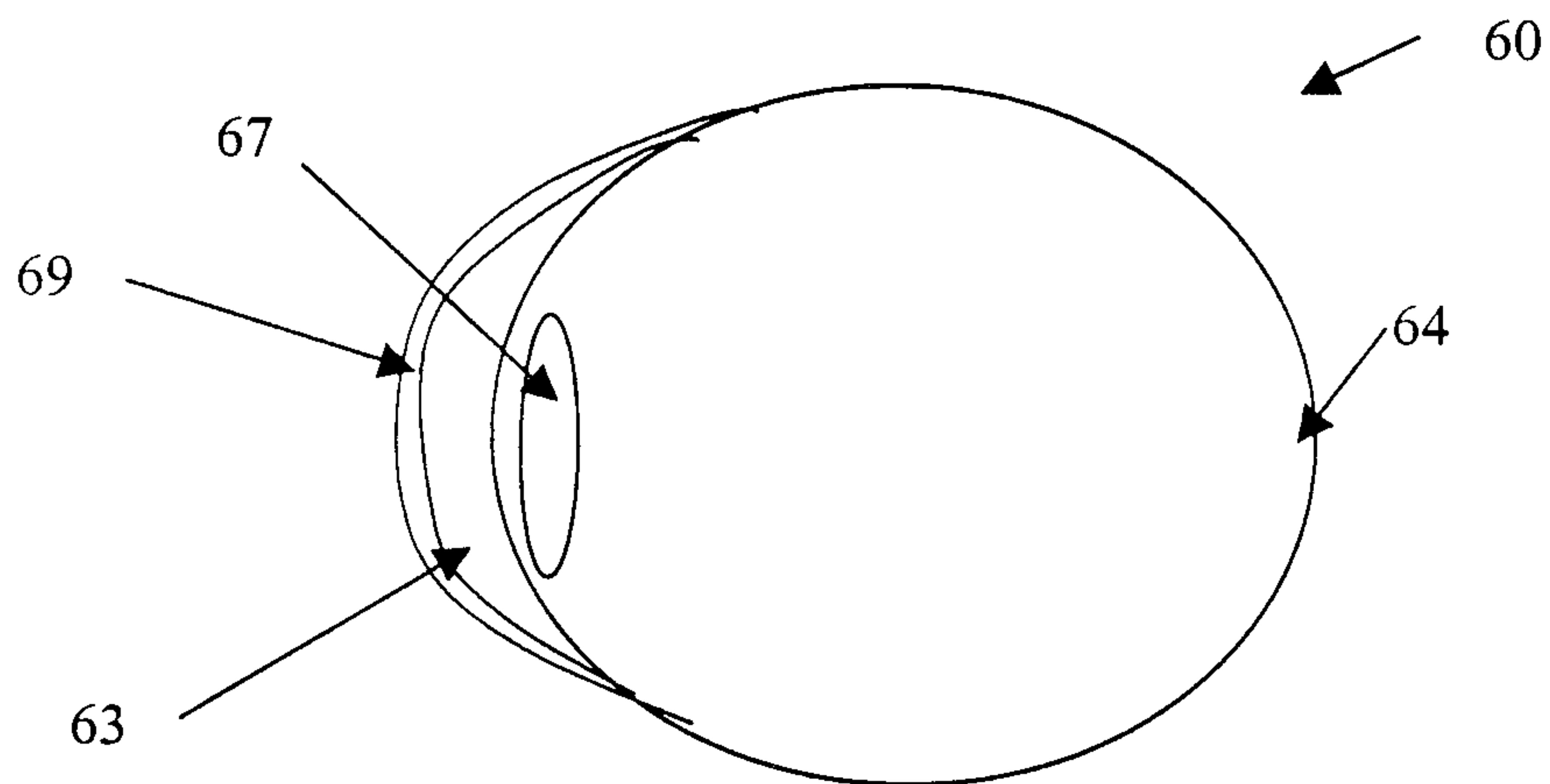

Fig. 1

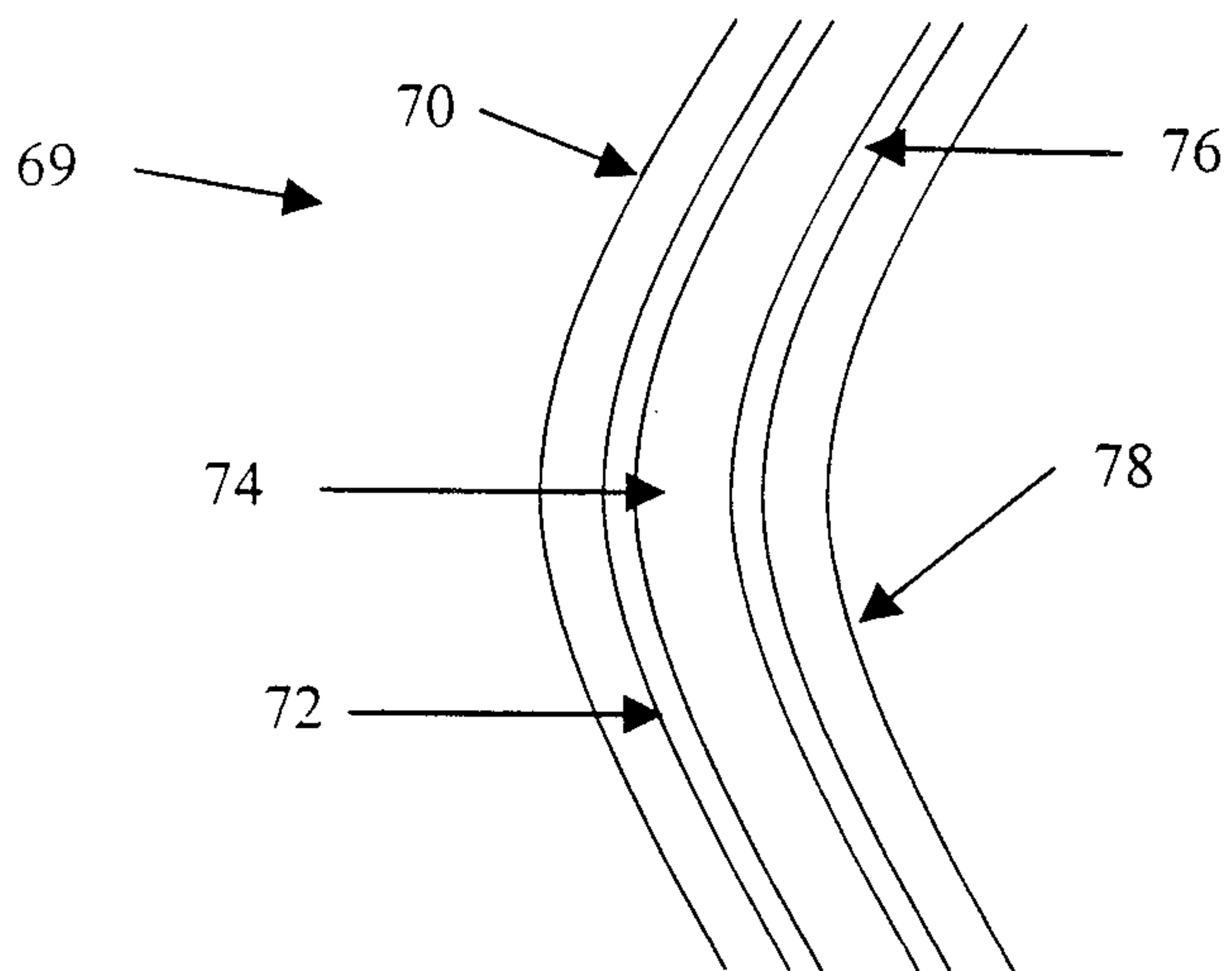

Fig. 2

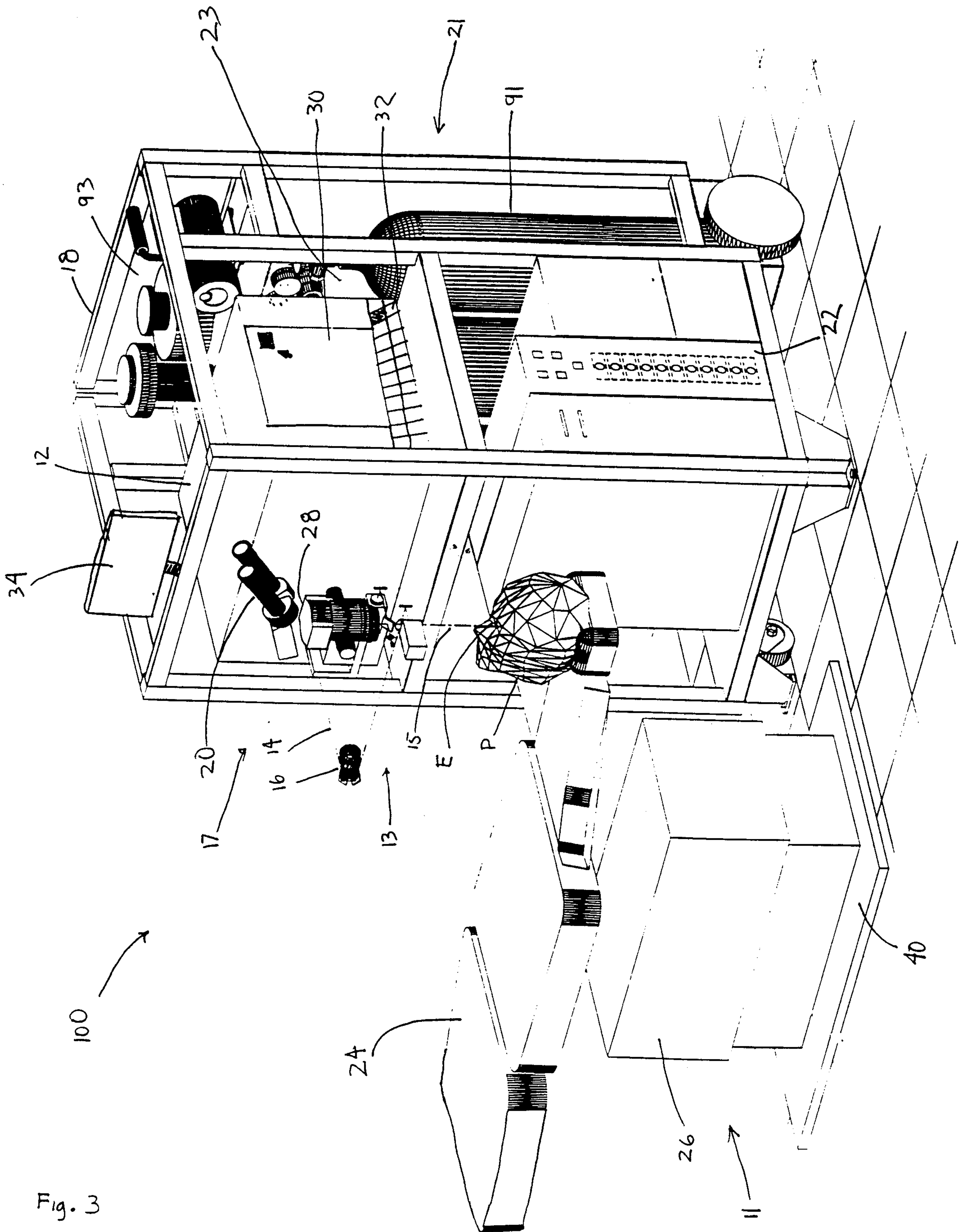

Fig. 3

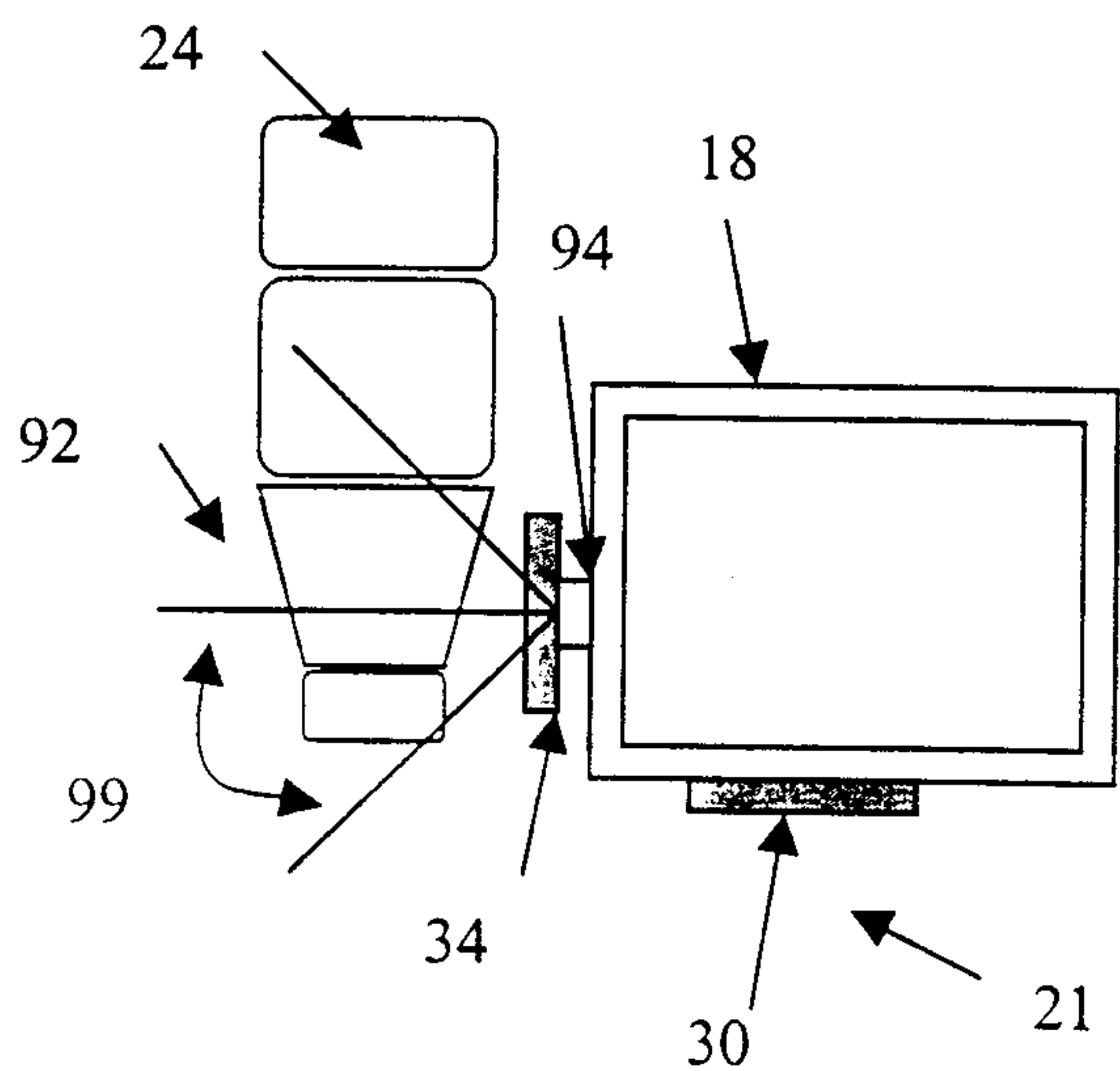

Fig. 4

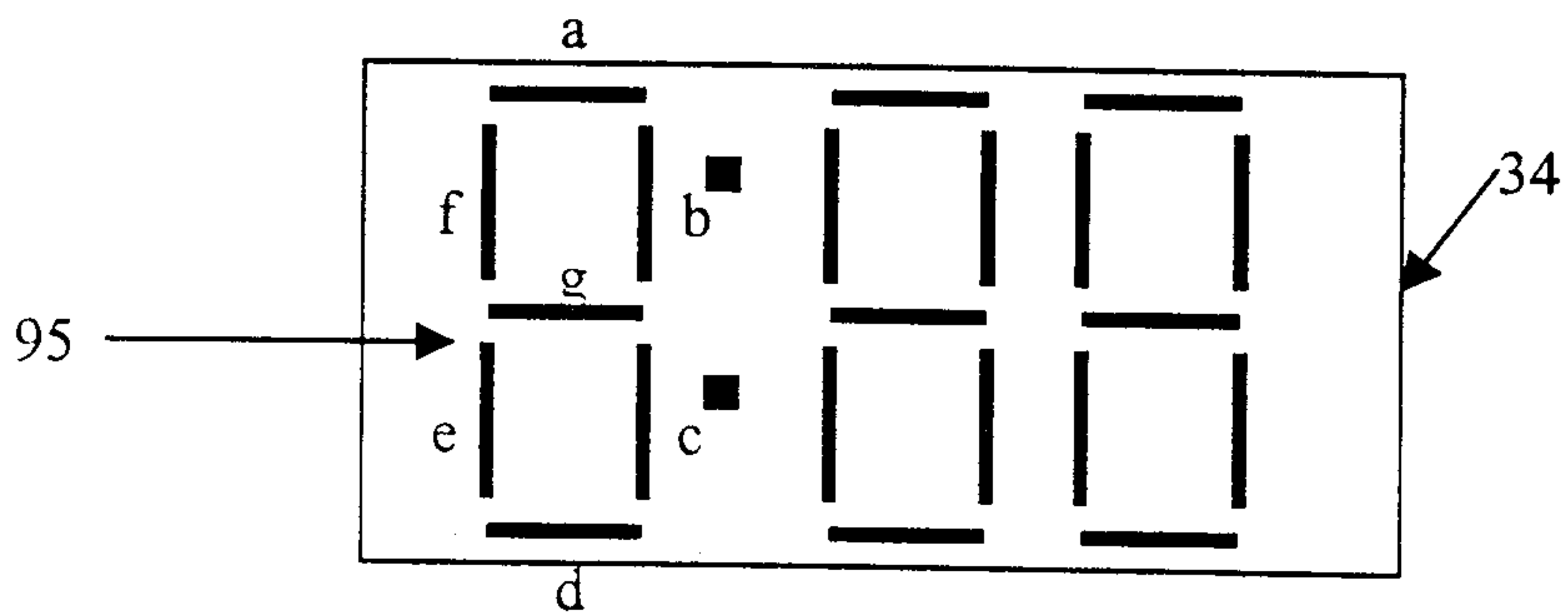

Fig. 4A

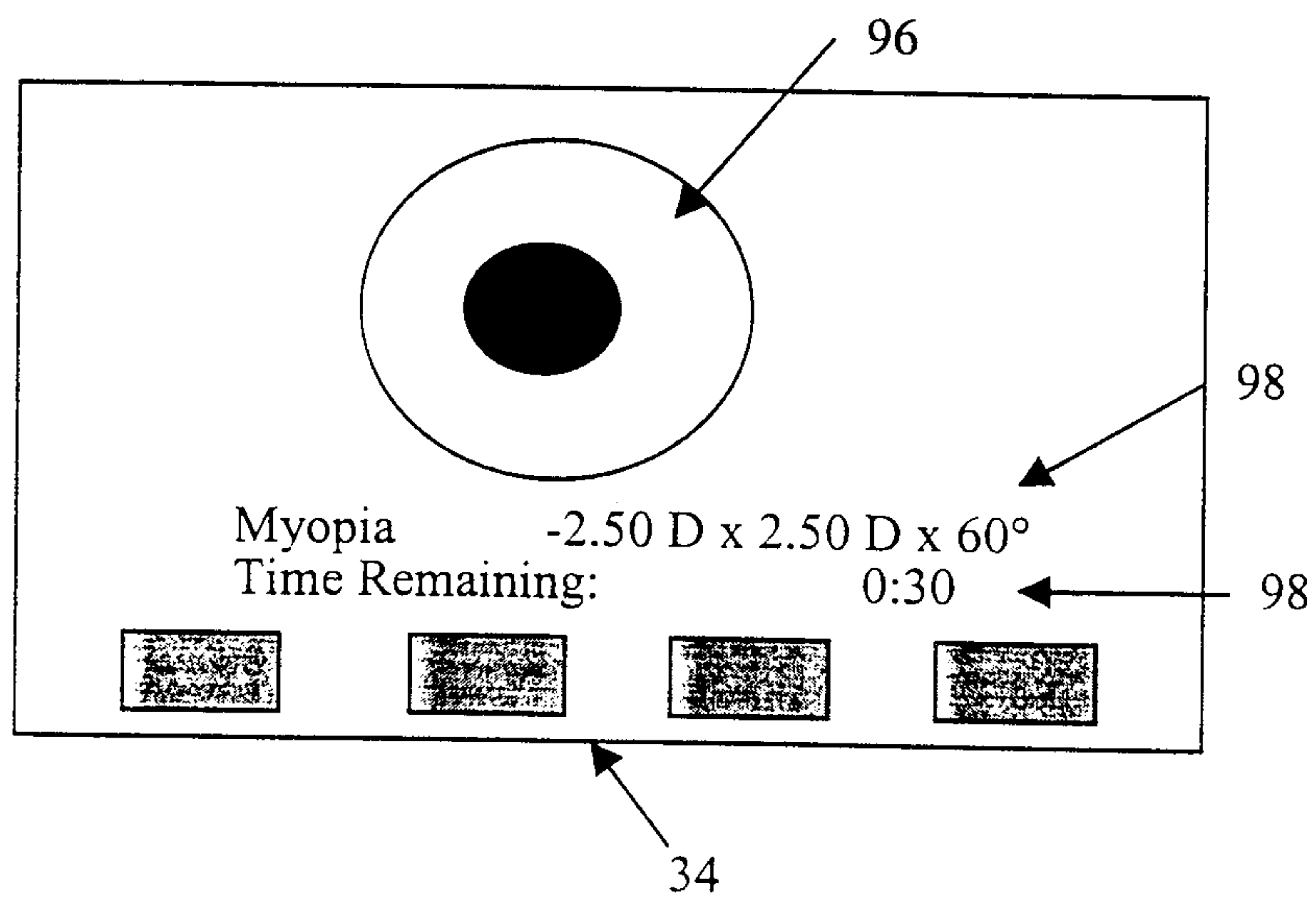

Fig. 4B

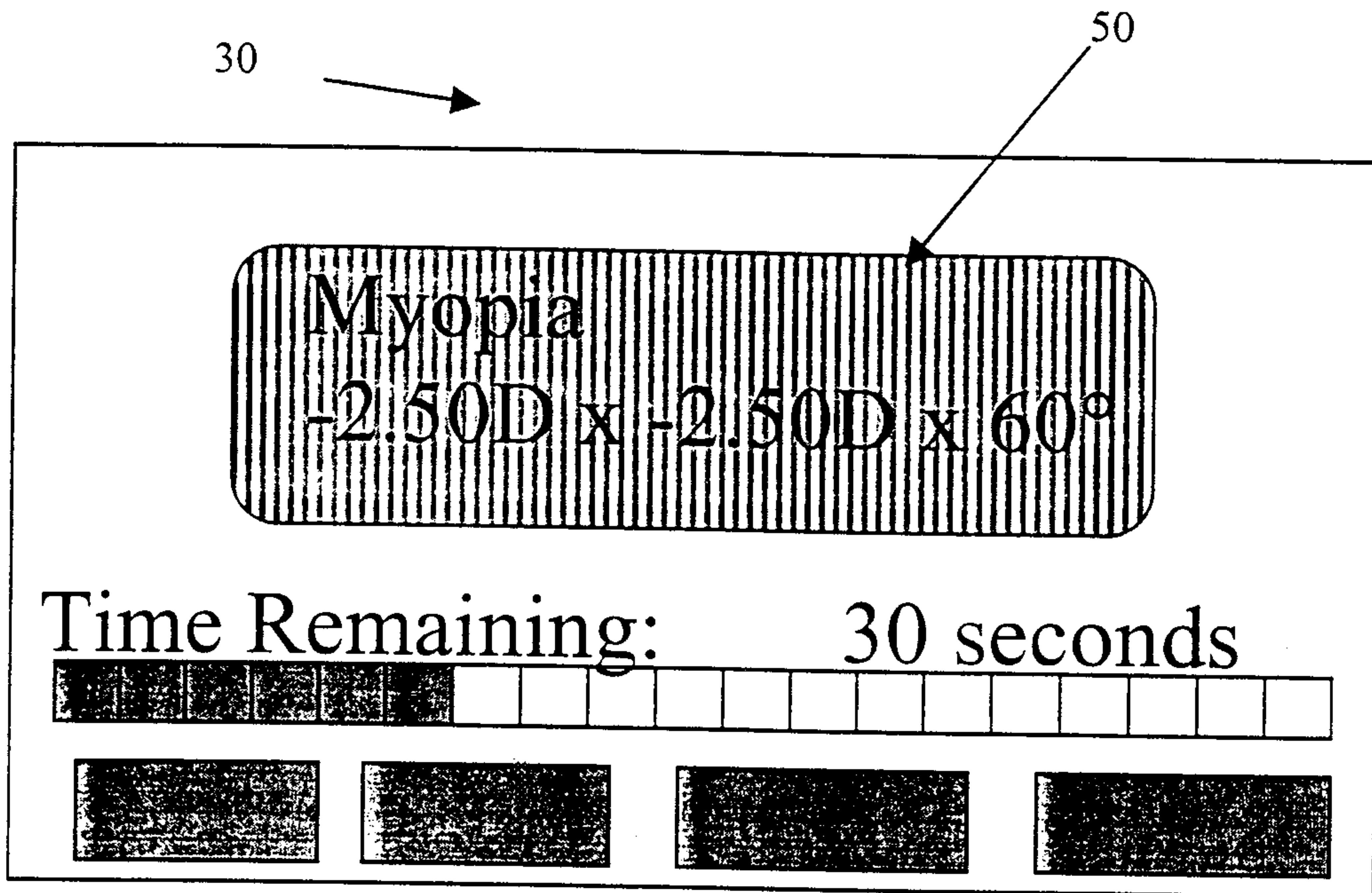

Fig. 5A

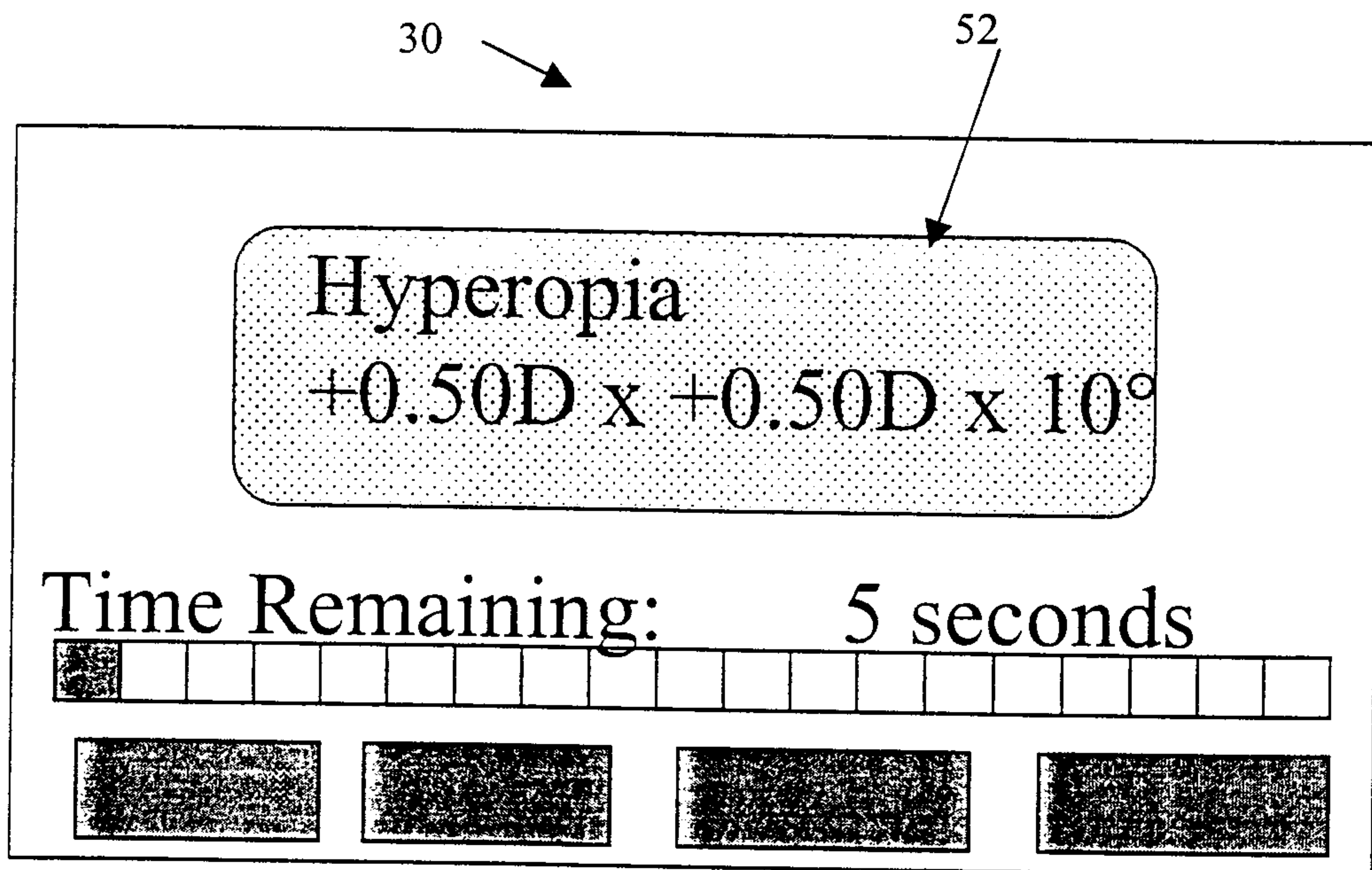

Fig. 5B

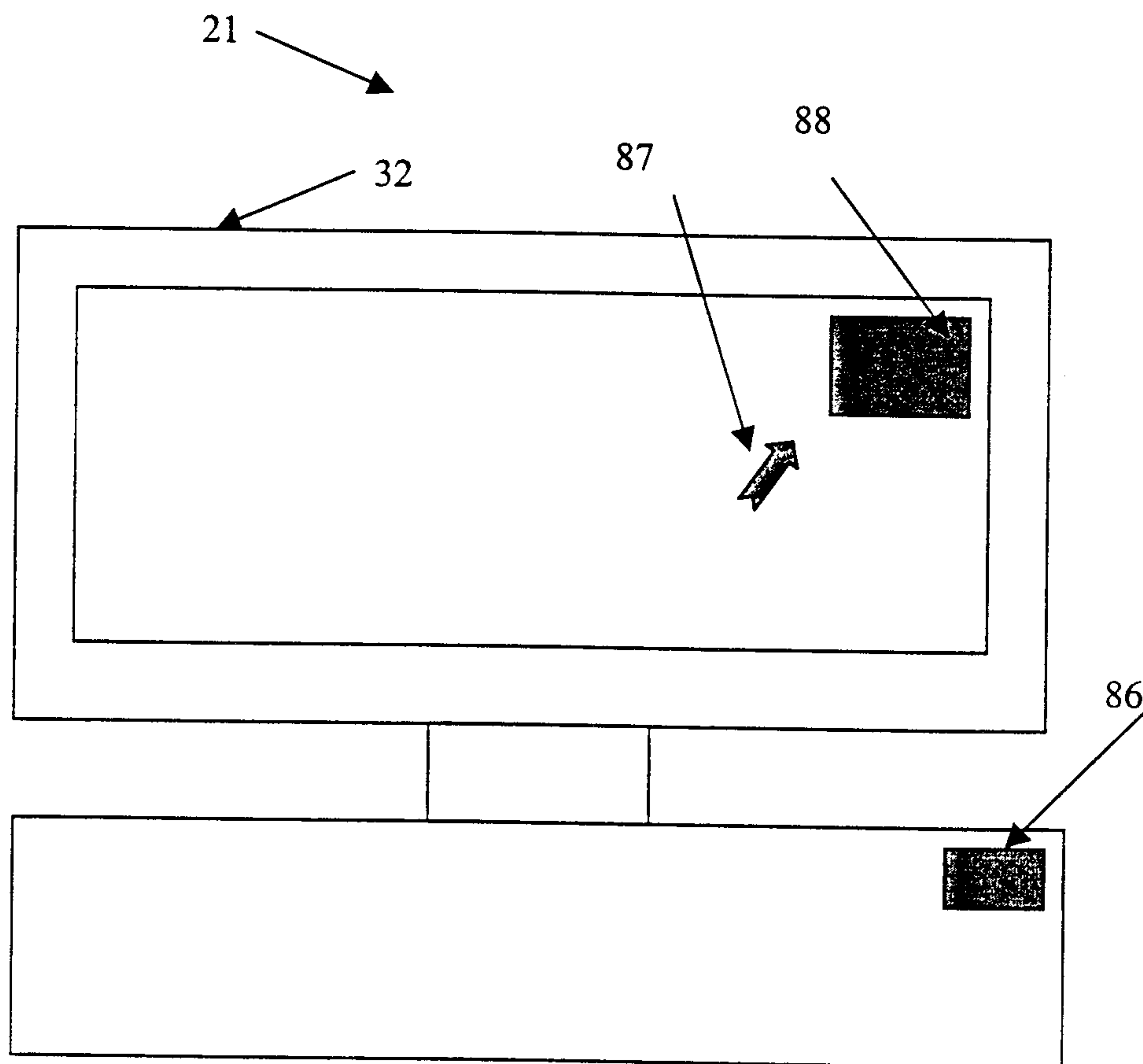

Fig. 6

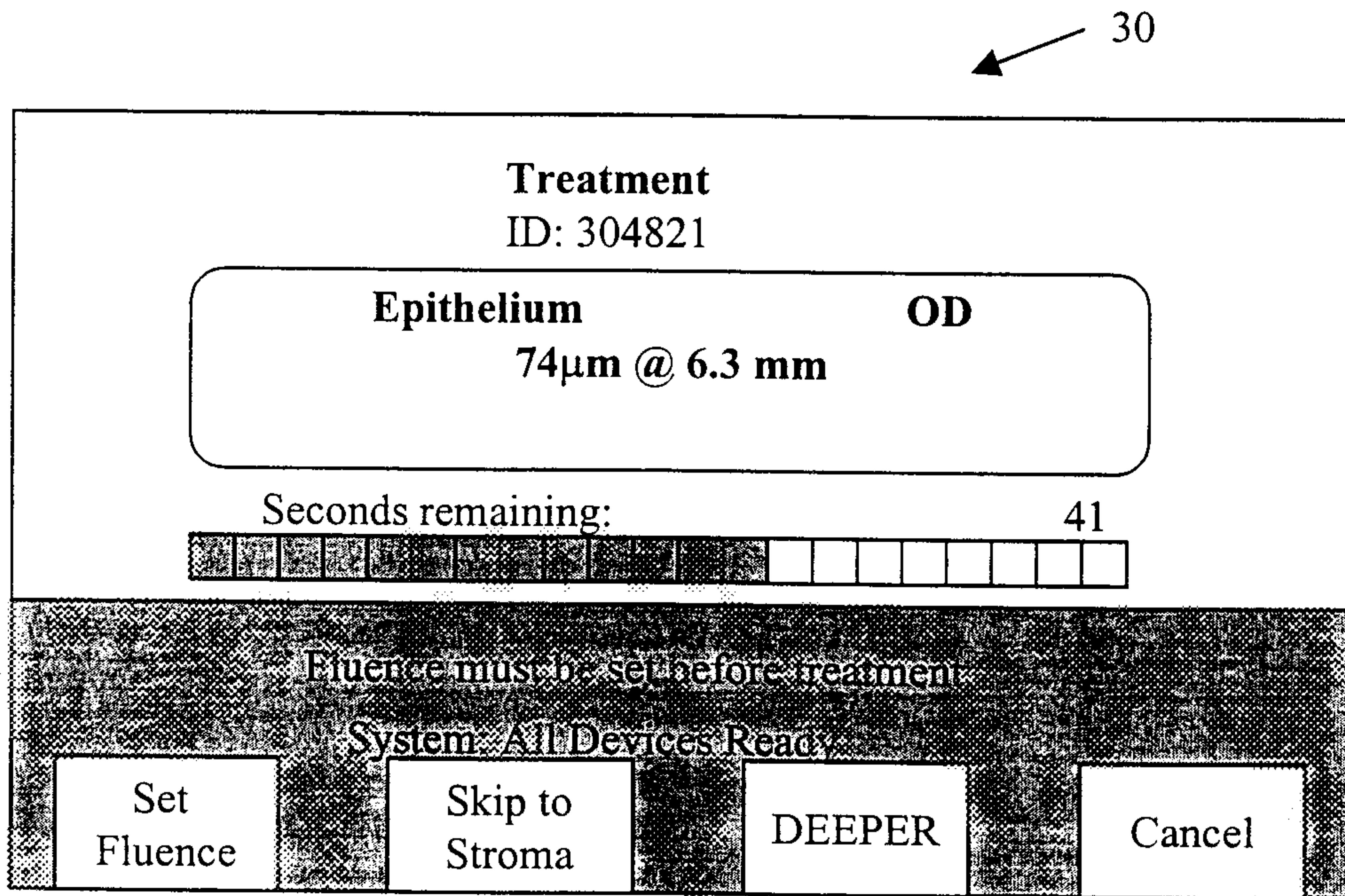

Fig. 7

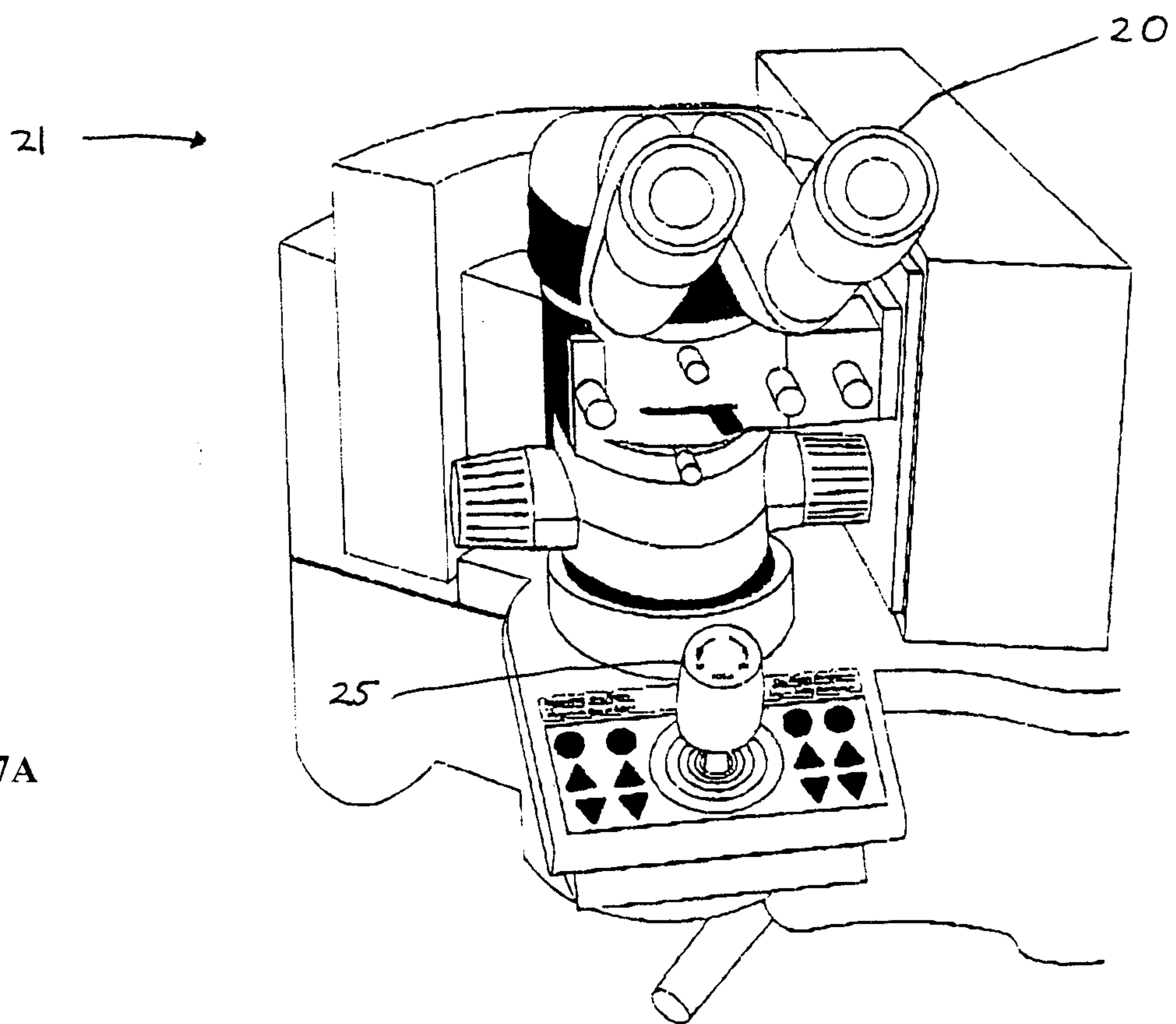

Fig. 7A

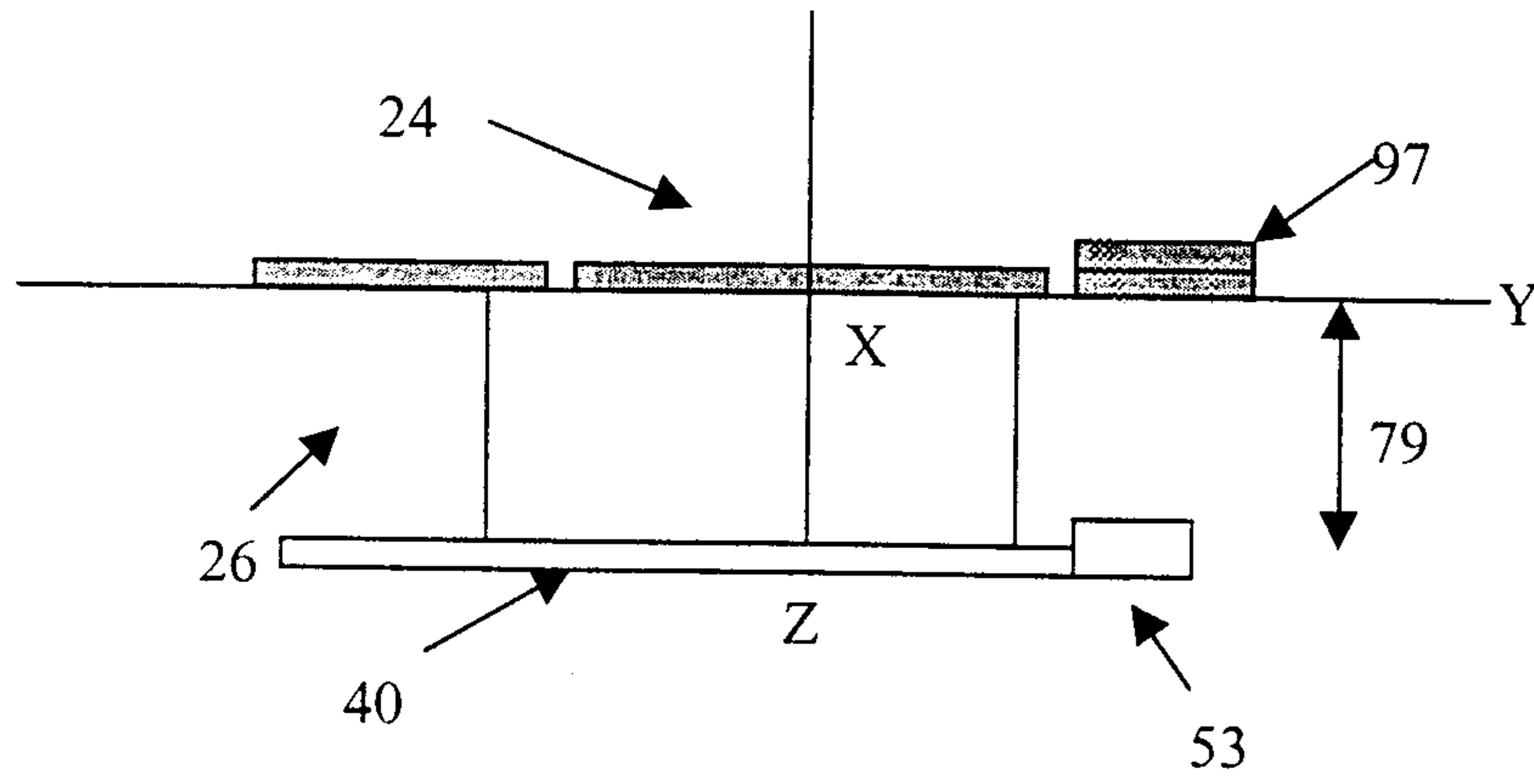

Fig. 8A

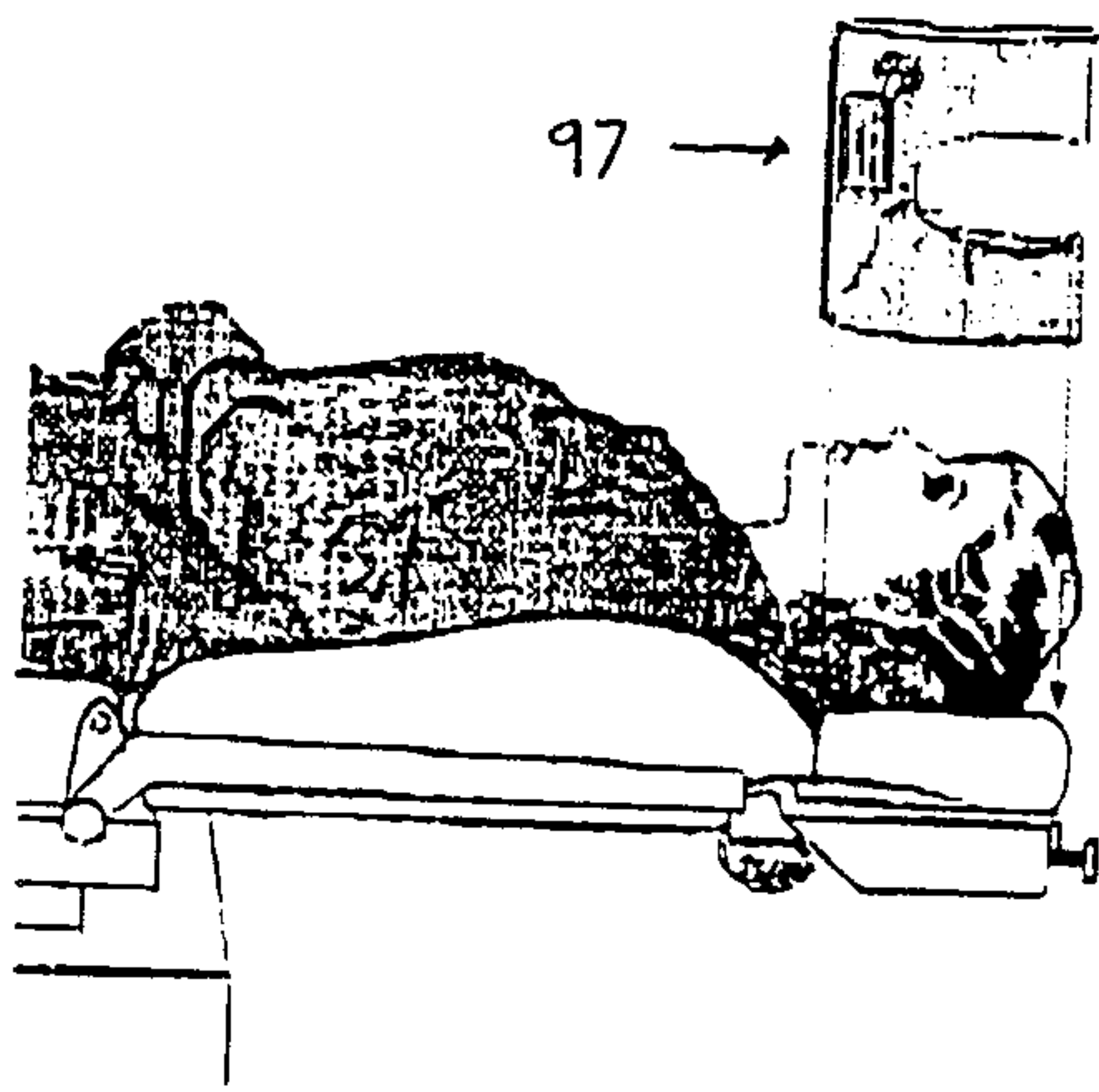

Fig. 8B

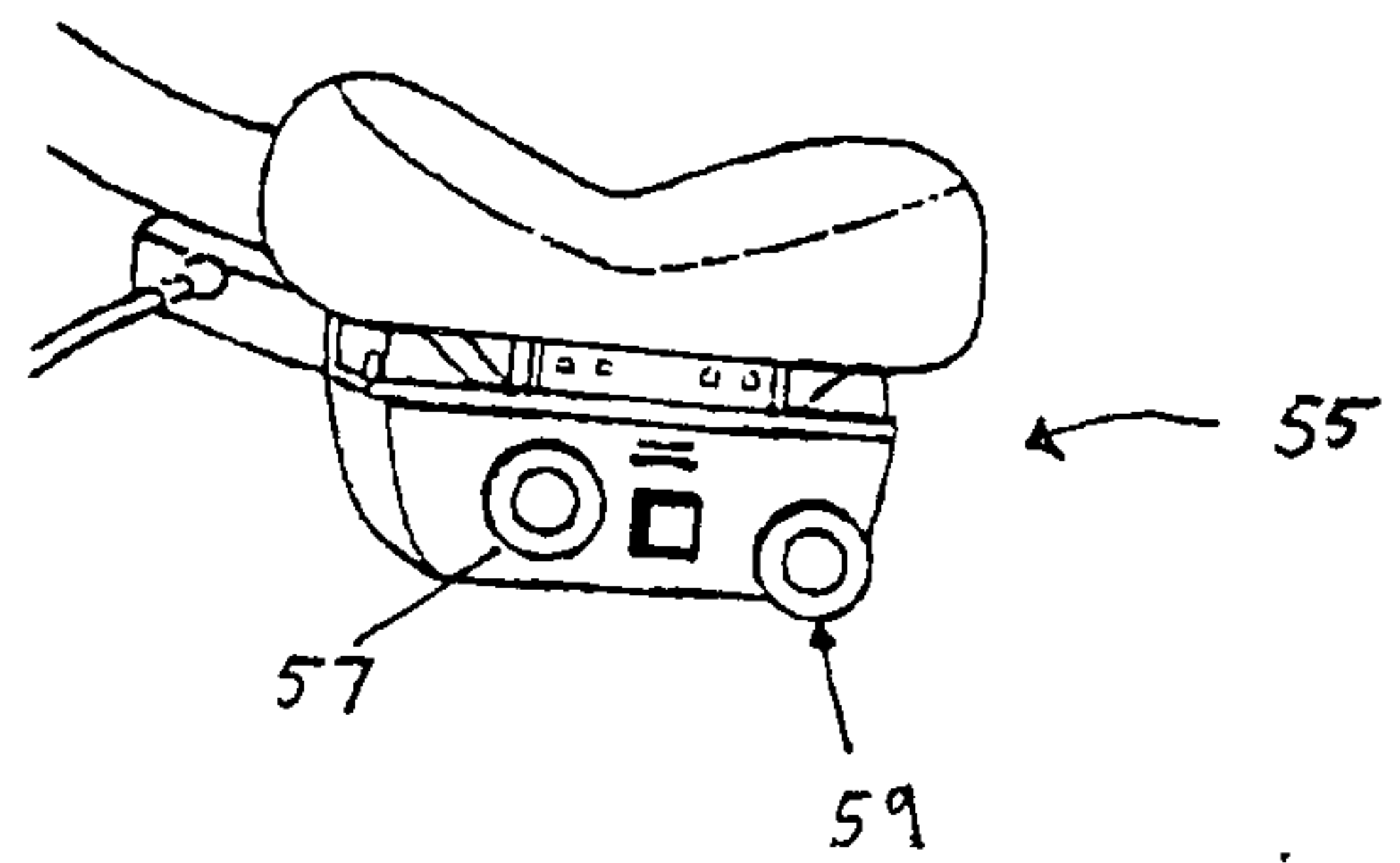

Fig. 8C

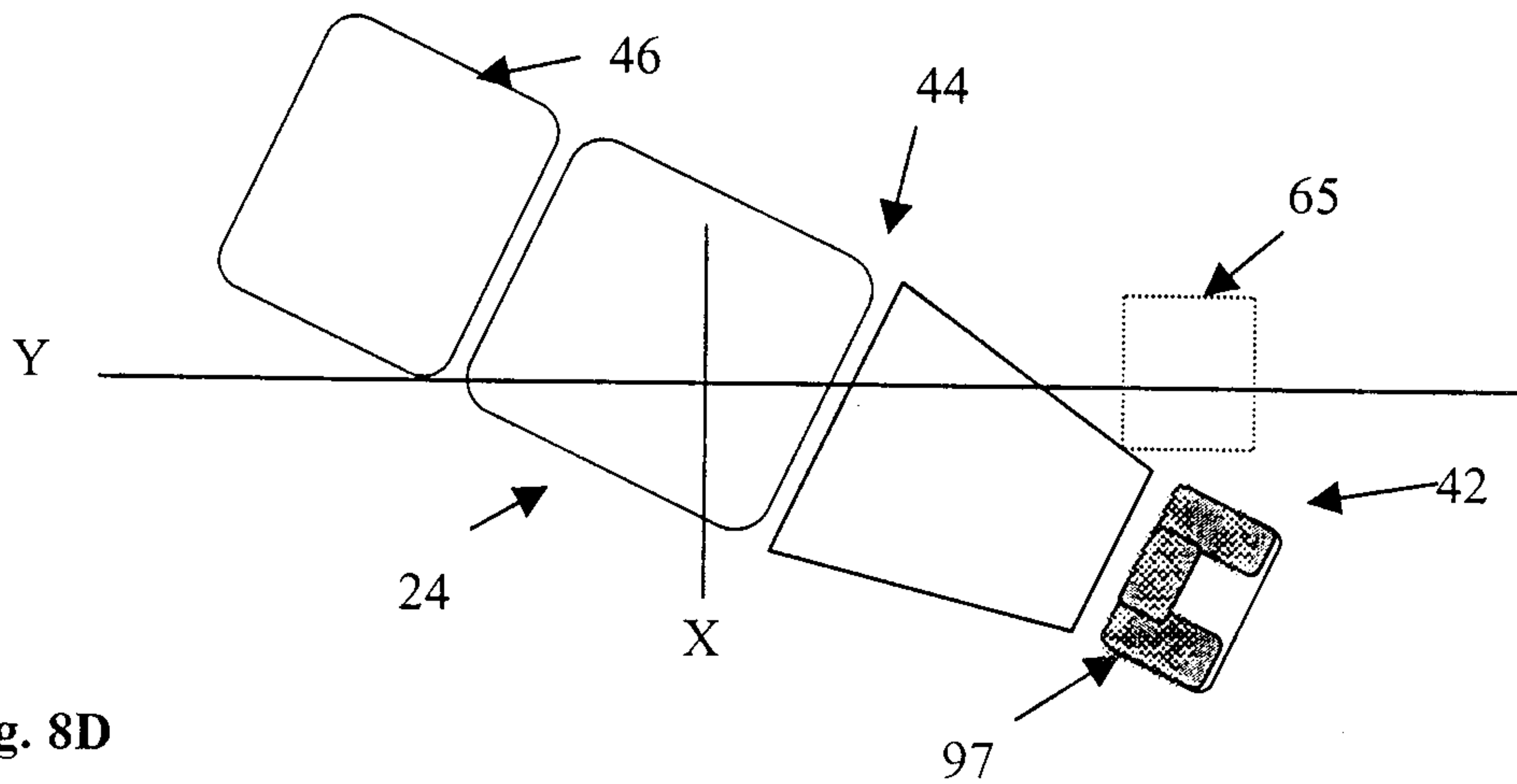

Fig. 8D

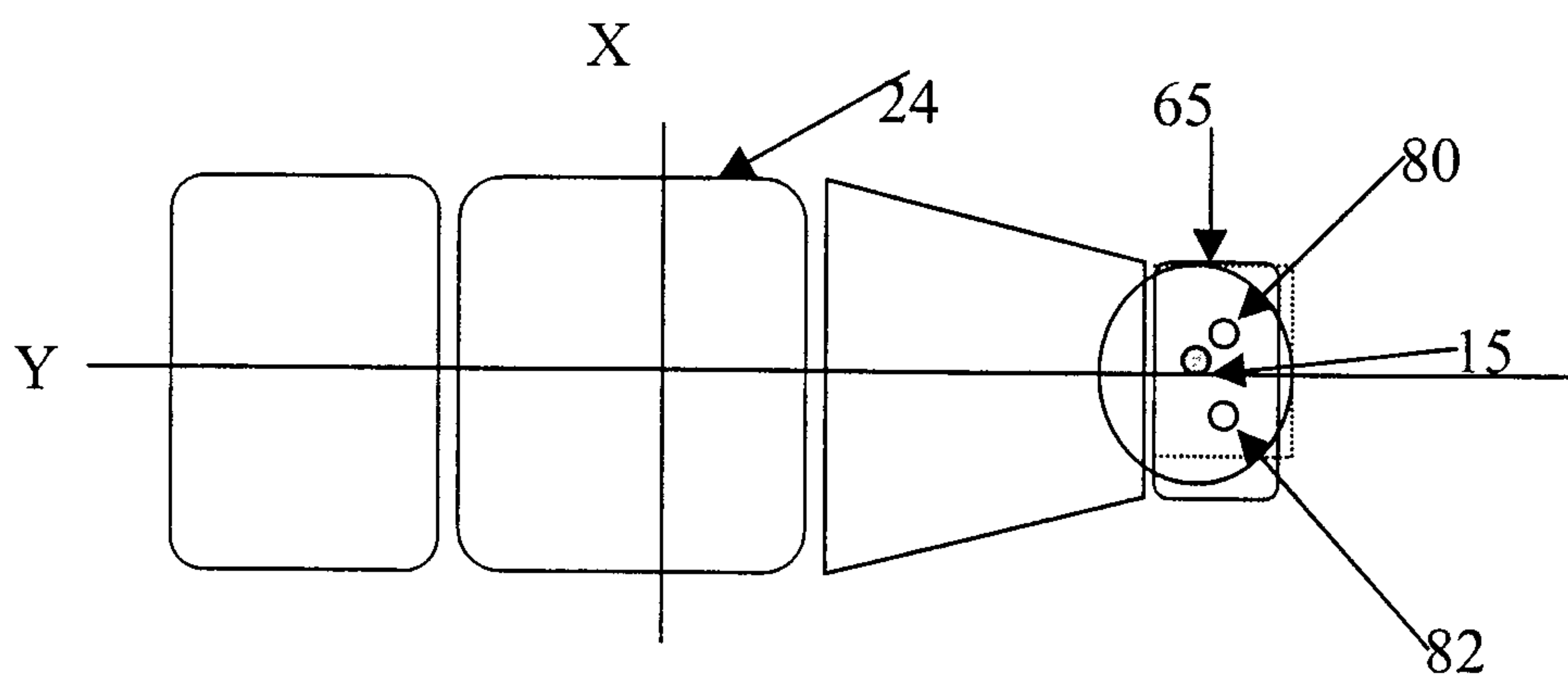

Fig. 8E

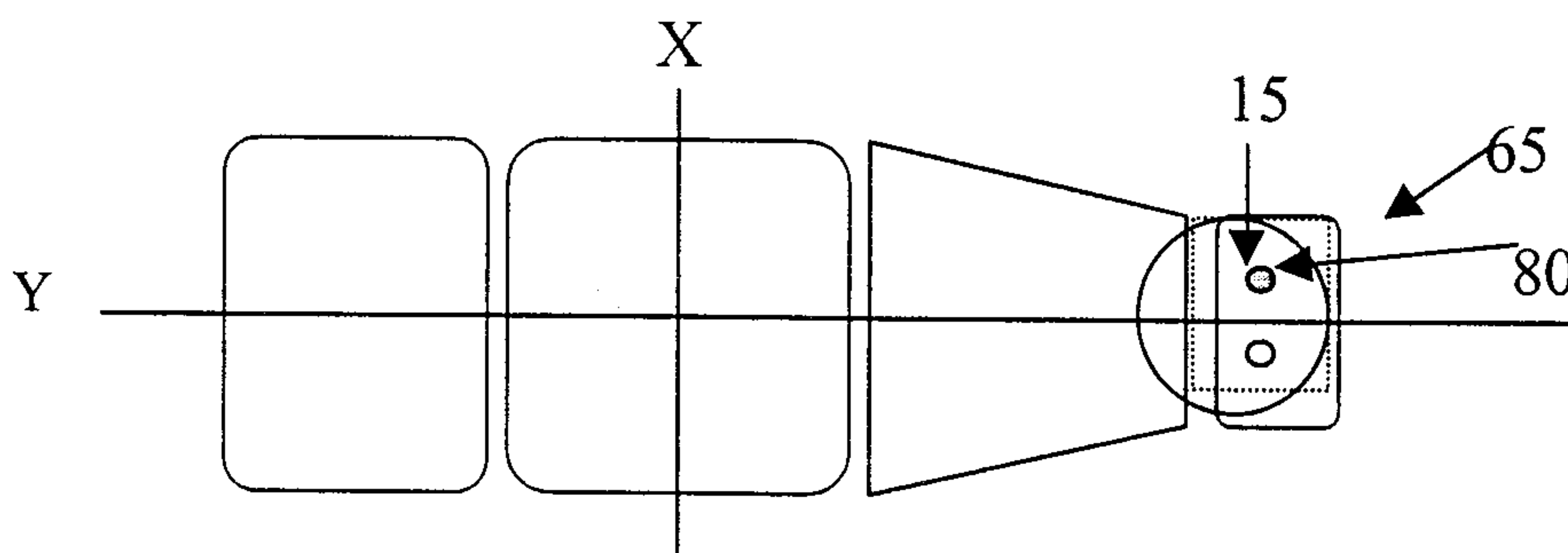

Fig. 8F

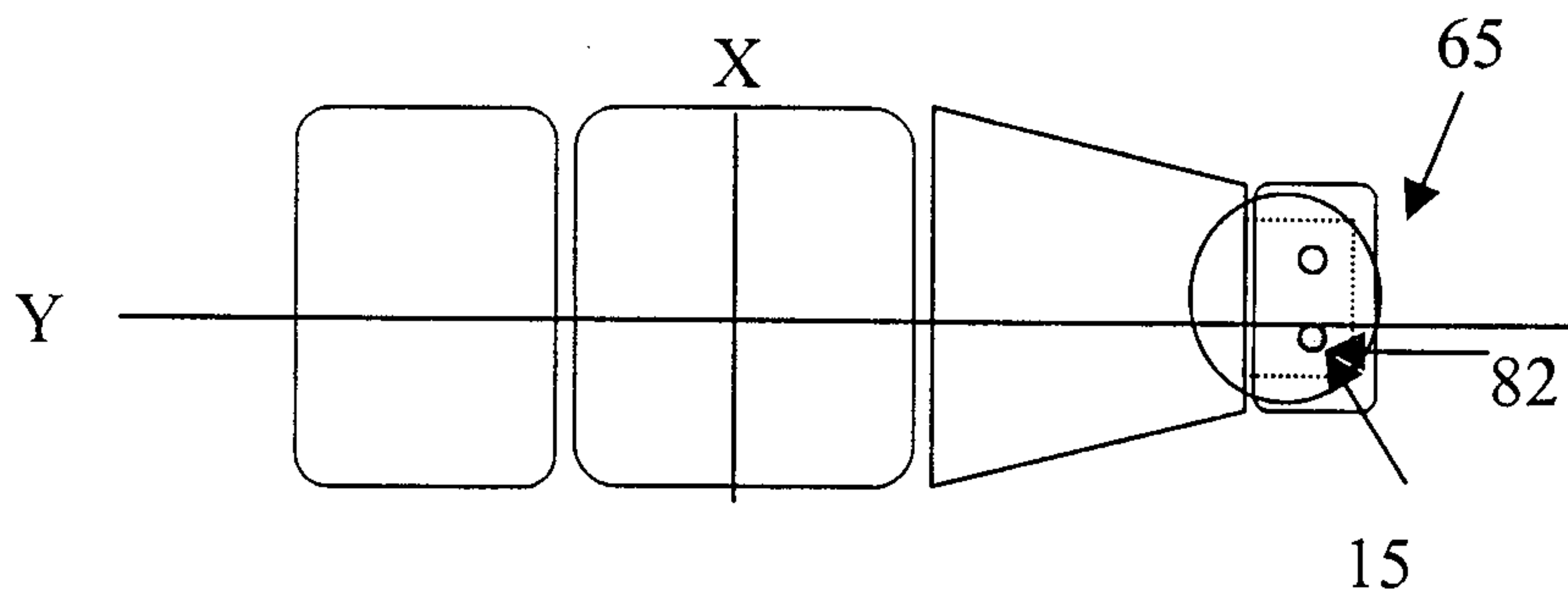

Fig. 8G

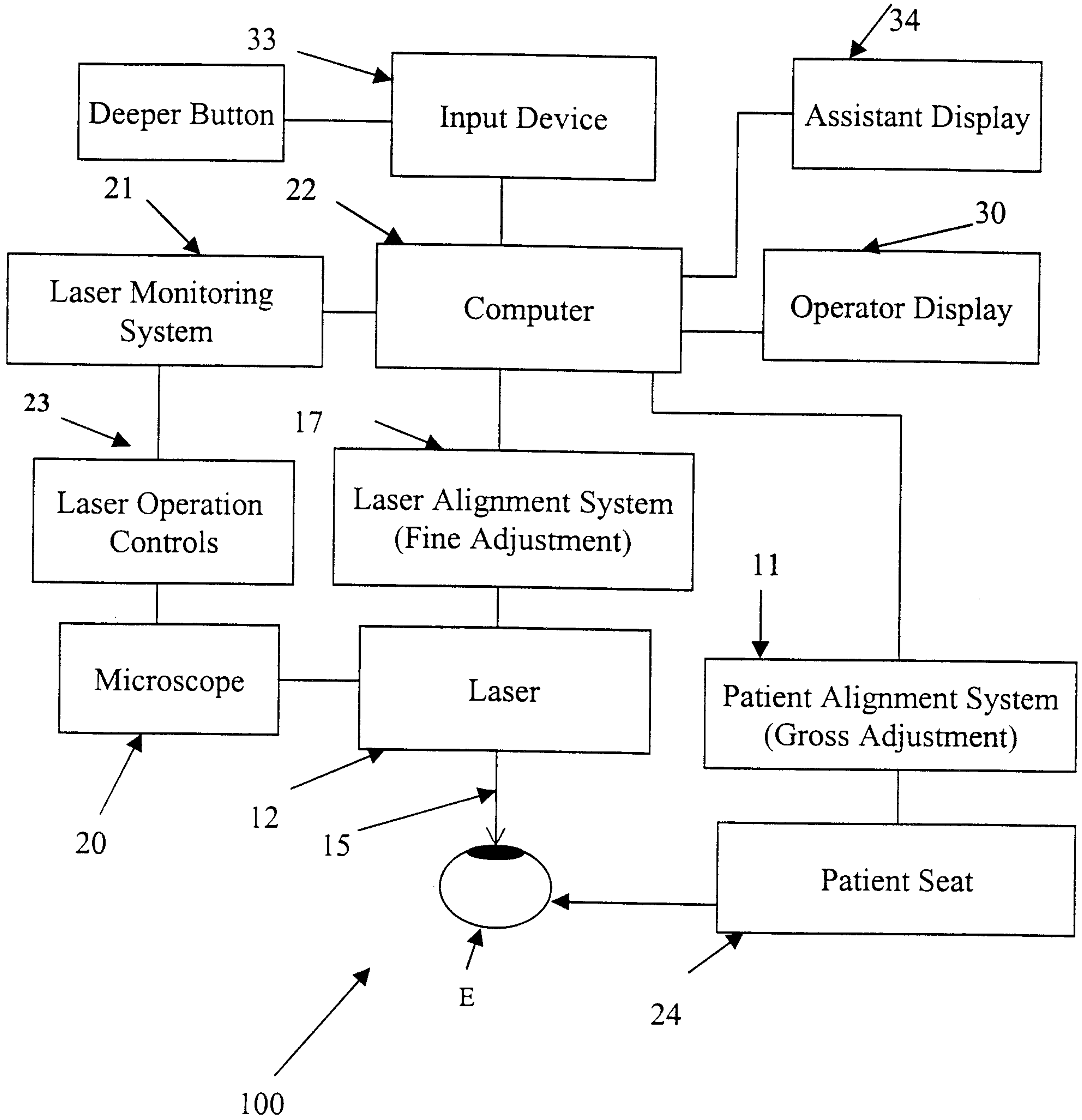

Fig. 9

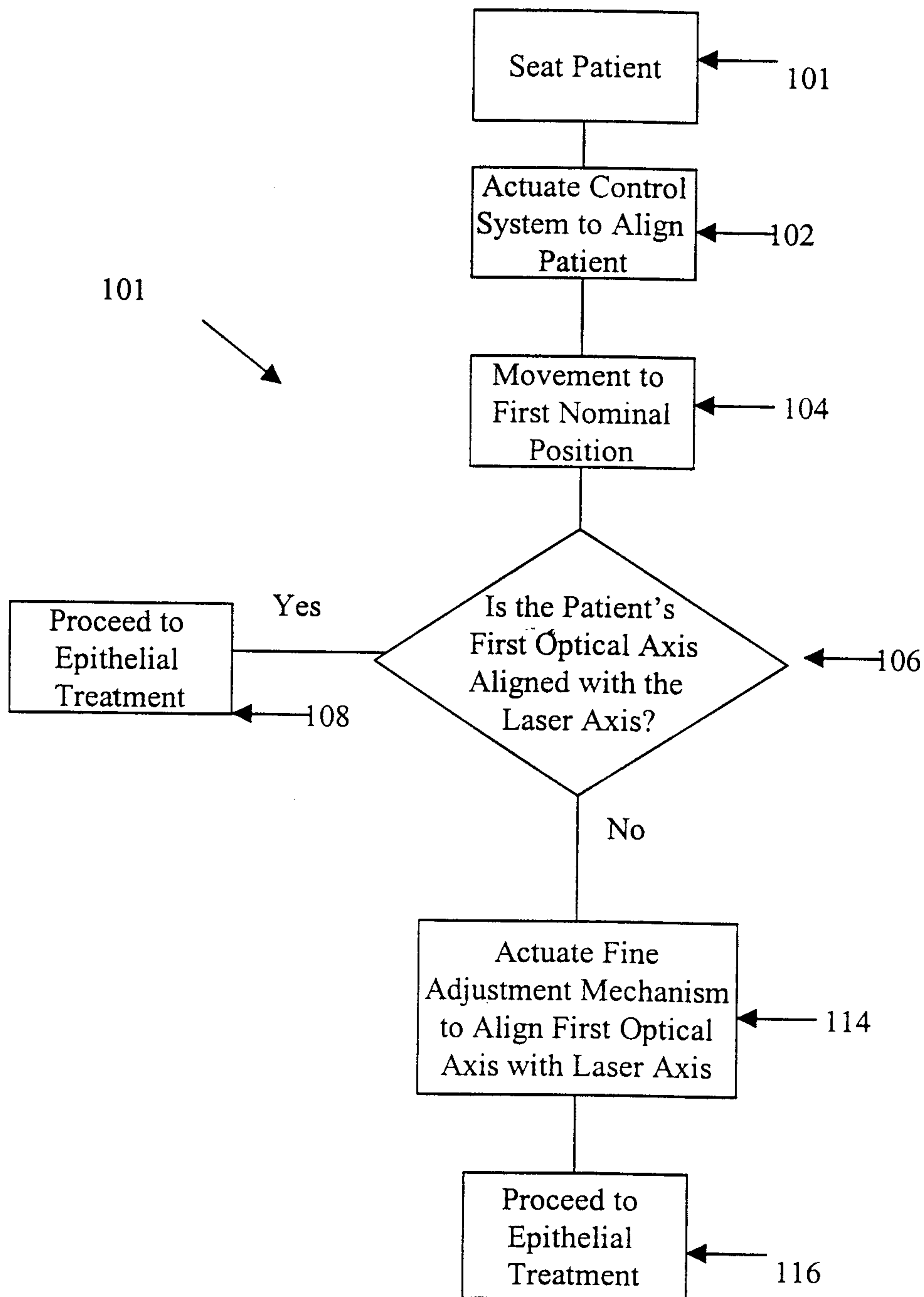

Fig. 10

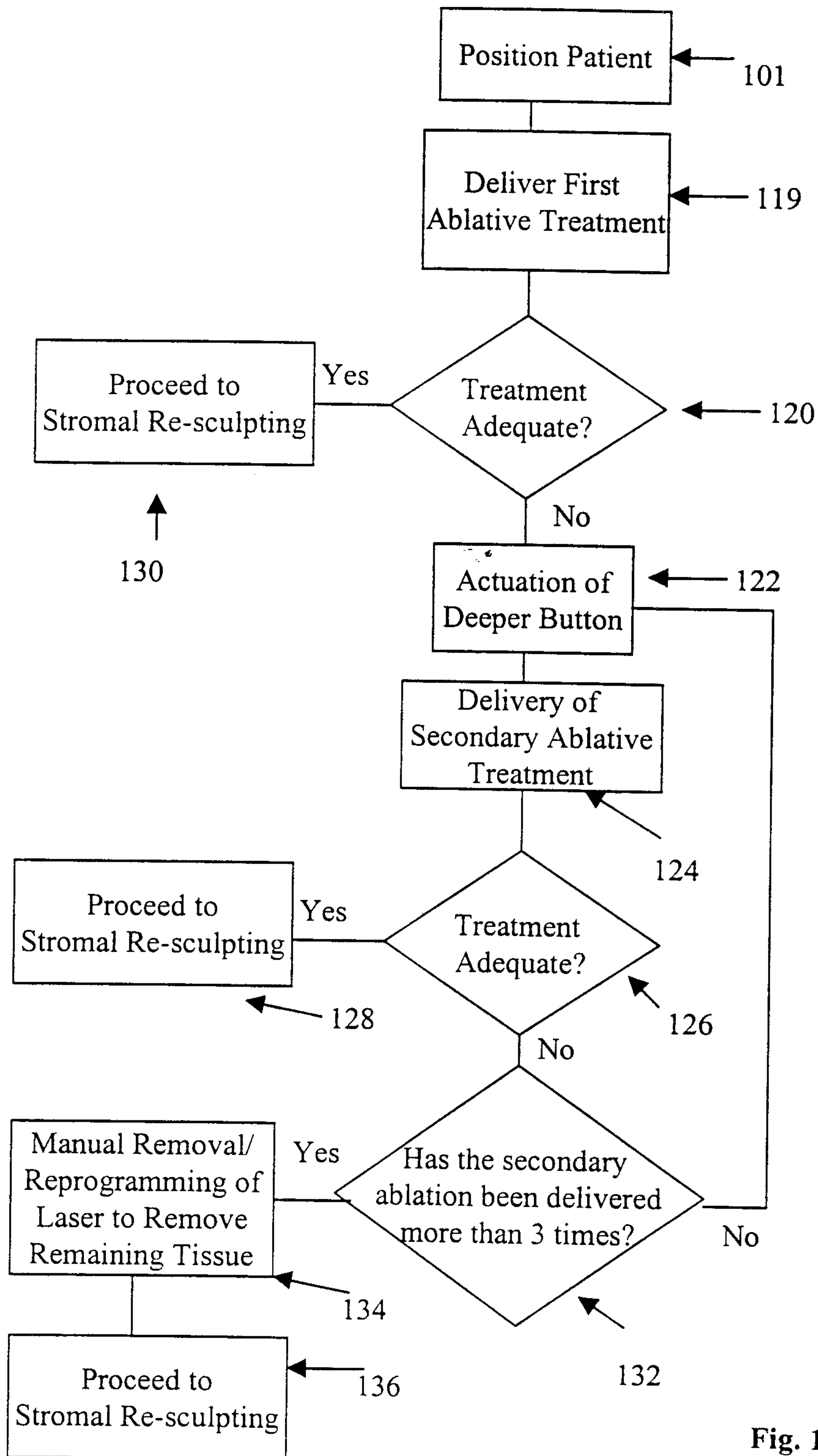

Fig. 11

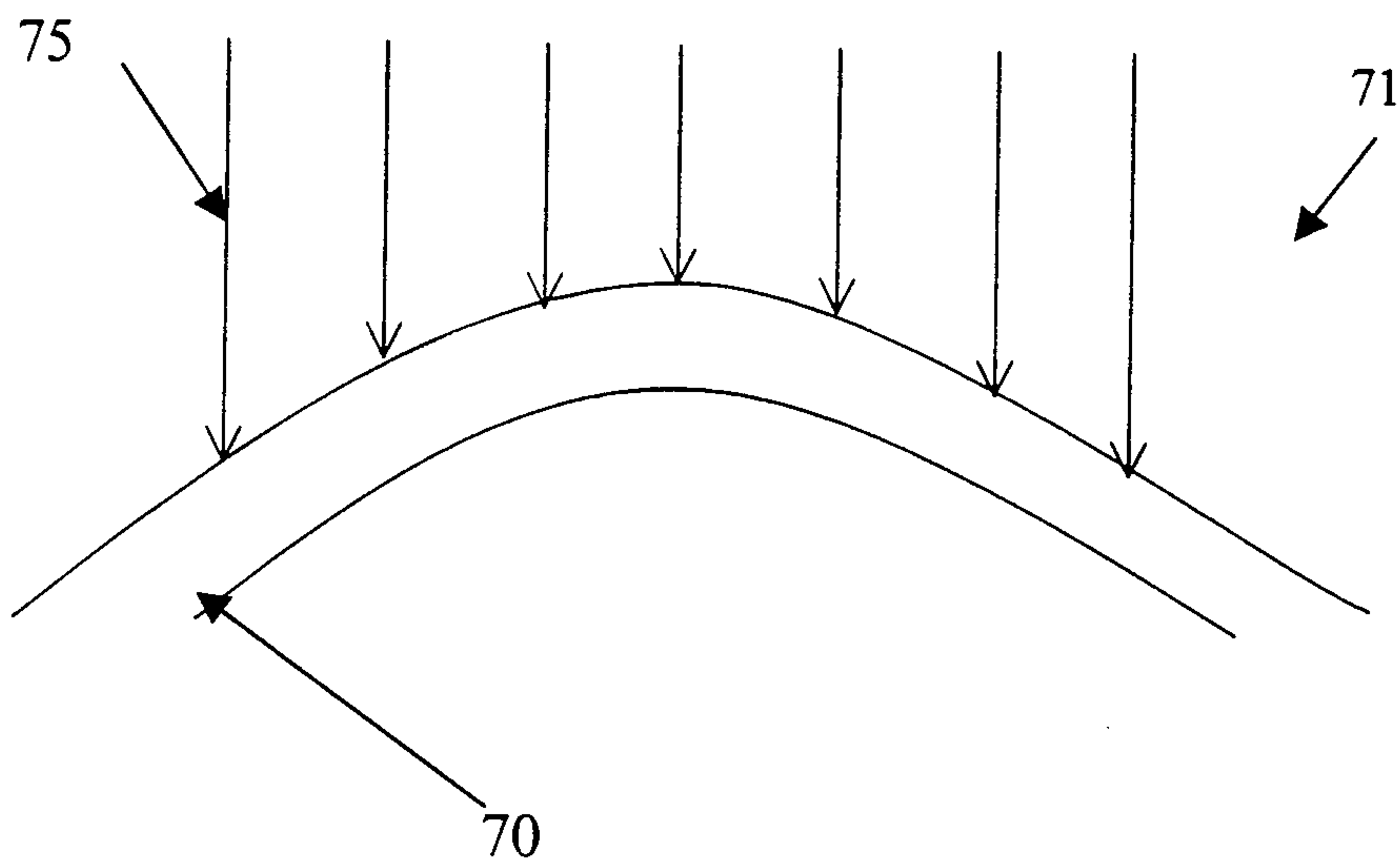

Fig. 11A

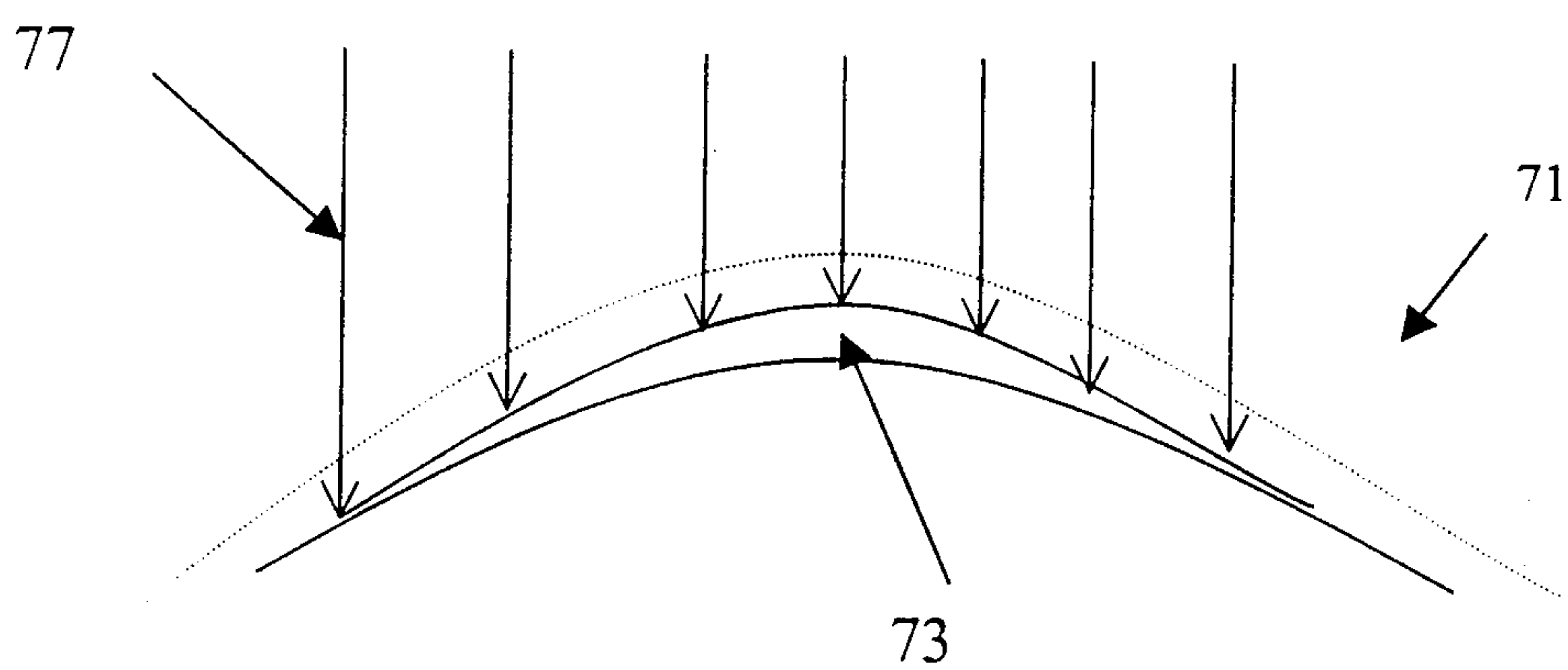

Fig. 11B

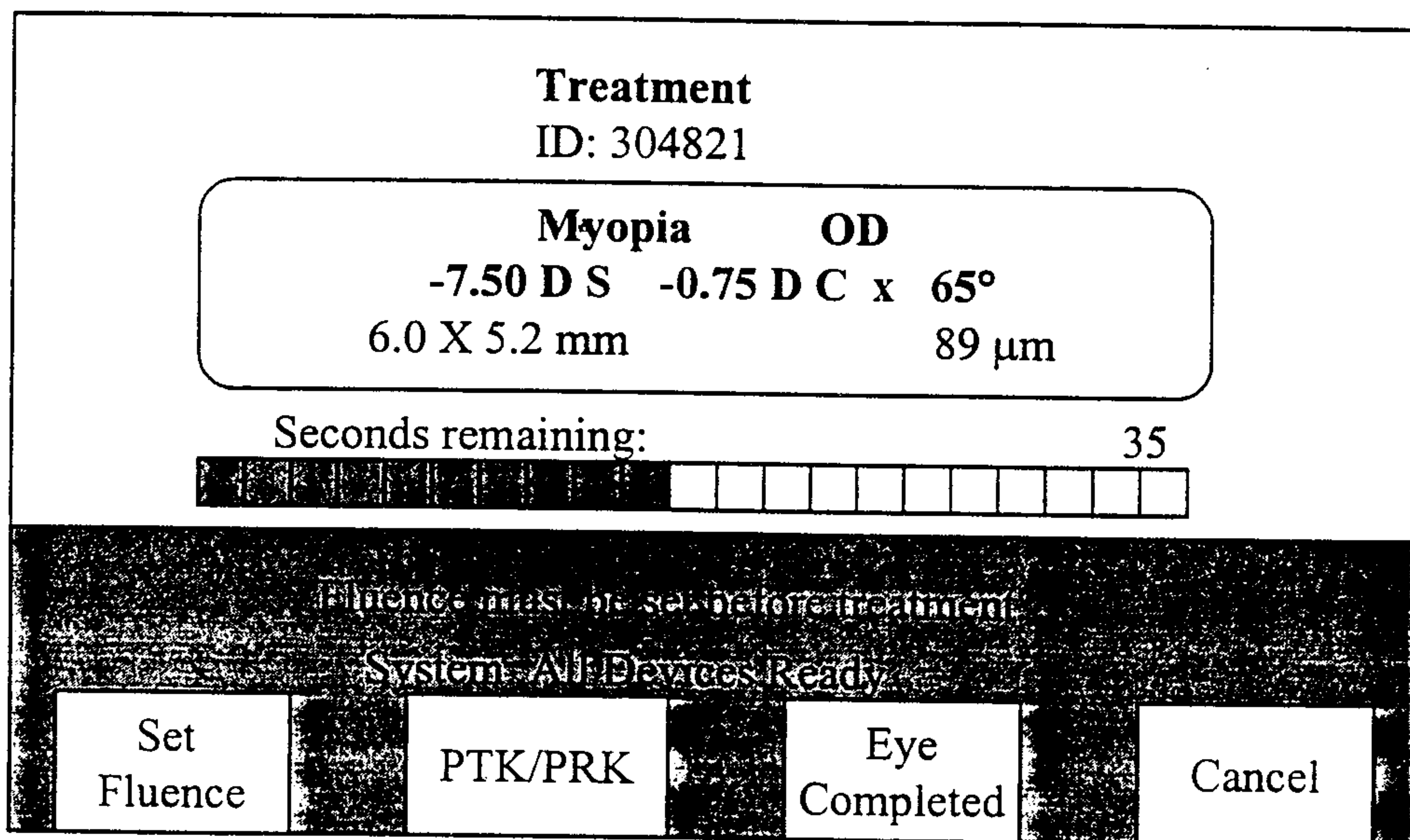

Fig. 12

