

R. A. STAHN.
Shingle Press.

No. 203,955.

Patented May 21, 1878.

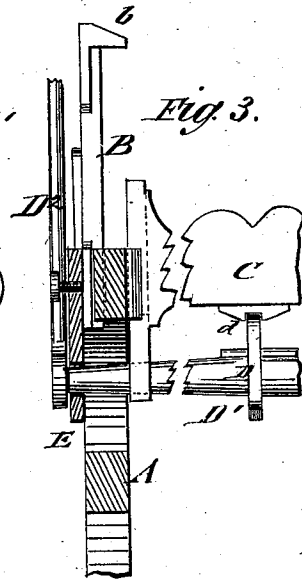
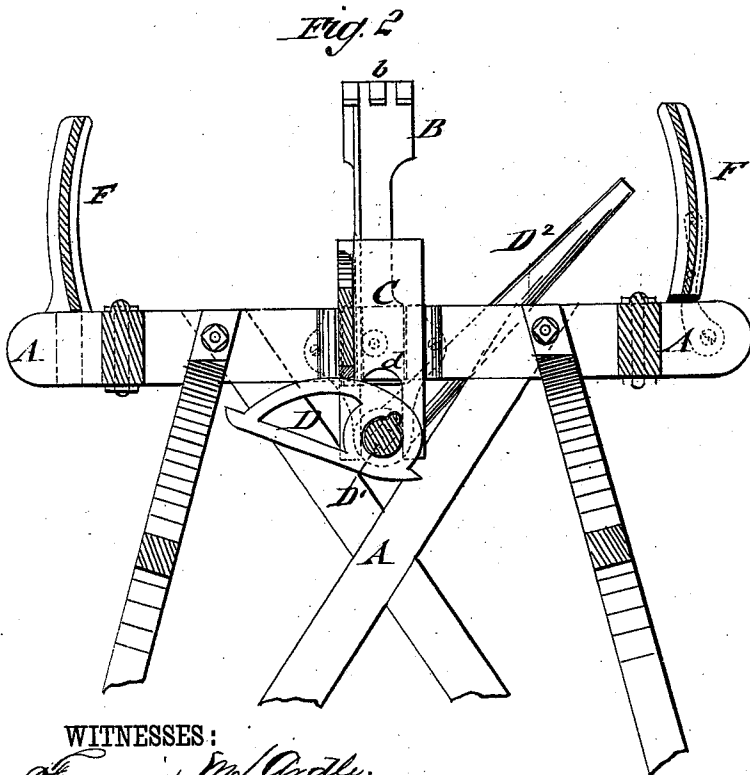
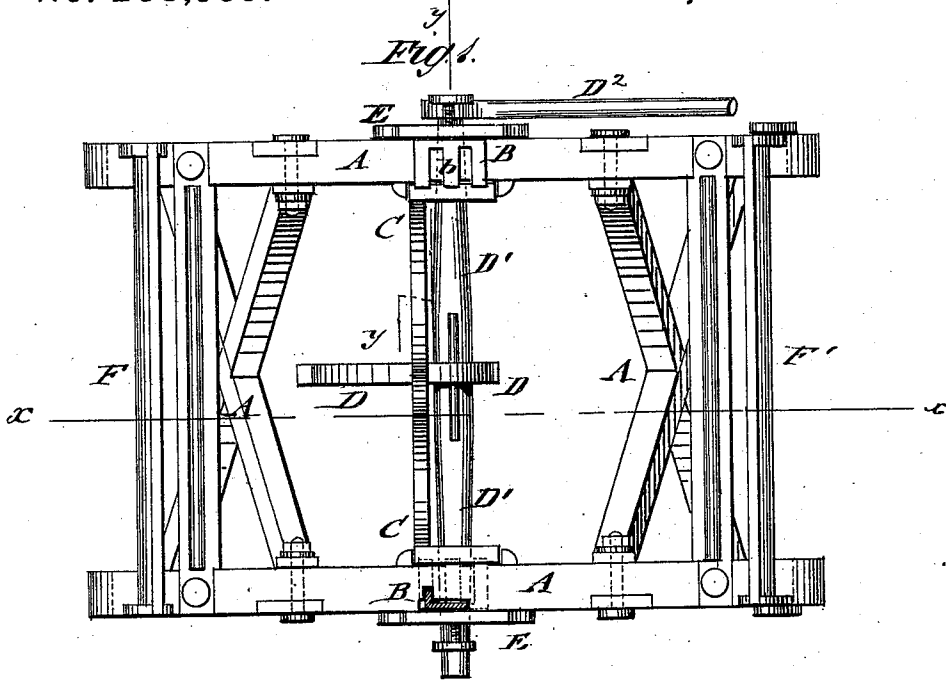

WITNESSES:

Francis McArdle.
C. Sedgwick

INVENTOR:

R. A. Stahn

BY

Munn & Co.

ATTORNEYS.

UNITED STATES PATENT OFFICE.

RUDOLPH A. STAHN, OF SOUTH STILLWATER, MINNESOTA.

IMPROVEMENT IN SHINGLE-PRESSES.

Specification forming part of Letters Patent No. 203,955, dated May 21, 1878; application filed January 18, 1878.

To all whom it may concern:

Be it known that I, RUDOLPH A. STAHN, of South Stillwater, county of Washington, State of Minnesota, have invented a new and Improved Shingle-Press, of which the following is a specification:

In the accompanying drawing, Figure 1 represents a top view of my improved shingle-press; and Figs. 2 and 3 are, respectively, a vertical longitudinal and a vertical transverse section of the same on lines *xx* and *yy*, Fig. 1.

Similar letters of reference indicate corresponding parts.

The object of the invention is to furnish an improved shingle-press, by which the shingles may be bunched, pressed, and tied with facility, the press being furthermore so constructed as to be readily taken to pieces, shipped, and set up again for work.

Referring to the drawing, A represents the supporting-frame of my improved shingle-press, which frame is stiffened by lateral braces, and its parts bolted together in such a manner that the entire frame may be taken to pieces for shipment and readily and firmly connected when being set up for use. The frame A is arranged at both sides with central ribbed standards B, that are guided in recesses of the frame and secured at any suitable height above the frame, according to the thickness of the shingles and size of the bunches to be made thereon. The standards B are provided at the top with inwardly-projecting seats or bearings *b*, that are recessed for the passage of the fastening wires or cords. Laterally between the standards B is placed a vertically-sliding follower, C, that is guided by inner side rails of the supporting-frame, and acted upon by an eccentric-cam, D, of a shaft, D¹, operated by a hand-lever, D². The cam D bears on a recessed bottom guide, *d*, of metal, and is keyed in suitable manner to the shaft.

The shaft D¹ is hung to bearings of hangers E, which are screwed to the outside of the frame A.

The side plates of the lateral follower C are centrally recessed, so as to ride over the shaft D¹ and slide up and down without interfering with the same. To the rear end of frame A is attached a fixed vertical gage-board, F, against which one set of shingles is butted, while the alternating set of shingles is laid with the thicker ends at the front end of the press, to which, by pivoted side arms, a swinging gage-board, F', is applied, that is raised when all the shingles are laid in position, so as to uniformly gage the alternating set of shingles. The shingles are then pressed by the action of the lever, eccentric, and follower between retaining cross-pieces that are placed crosswise at the bottom and top, one resting on the follower, the other against the projecting seats of the standard. When the shingles are pressed to the required degree, they are firmly tied by the wires passed through the recesses of the top seats. In case one of the binders breaks, another one can be put in without losing the shape of the bundle, as this is firmly held between follower and top seats of standards. When the shingles are thus bundled, the front gage-board is swung down and the bundle then removed from the press, which is then ready for the next quantity of shingles.

Having thus fully described my invention, I claim as new and desire to secure by Letters Patent—

A shingle-press provided with a cam, D, and recessed guide *d*, arranged as and for the purpose specified.

RUDOLPH A. STAHN.

Witnesses:

LOUIS BERGERON,
JOHN BERGERON.