

(19) **DANMARK**

(10) **DK/EP 1419672 T4**



Patent- og  
Varemærkestyrelsen

(12) **Oversættelse af ændret  
europæisk patentskrift**

- 
- (51) Int.Cl.: **H 04 R 3/00 (2006.01)**
- (45) Oversættelsen bekendtgjort den: **2015-10-19**
- (80) Dato for Den Europæiske Patentmyndigheds bekendtgørelse om opretholdelse af patentet i ændret form: **2015-07-22**
- (86) Europæisk ansøgning nr.: **01982007.5**
- (86) Europæisk indleveringsdag: **2001-10-24**
- (87) Den europæiske ansøgnings publiceringsdag: **2004-05-19**
- (86) International ansøgning nr.: **CA2001001509**
- (87) Internationalt publikationsnr.: **WO2003024152**
- (30) Prioritet: **2001-09-07 CA 2357200**
- (84) Designerede stater: **AT BE CH CY DE DK ES FI FR GB GR IE IT LI LU MC NL PT SE TR**
- (73) Patenthaver: **Semiconductor Components Industries, LLC, 5005 E. McDowell Road, Phoenix, AZ 85008, USA**
- (72) Opfinder: **BRENNAN, Robert, 42 Forest Breeze Court, Kitchener, Ontario N2N 3H9, Canada**  
**SCHNEIDER, Todd, 468 Stillmeadow Circle, Waterloo, Ontario N2L 5M3, Canada**  
**NIELSEN, Jakob, 5 Father David Bauer Drive, Unit 313, Waterloo, N2L 6M2 Ontario, Canada**
- (74) Fuldmægtig i Danmark: **NORDIC PATENT SERVICE A/S, Bredgade 30, 1260 København K, Danmark**
- (54) Benævnelse: **LYTTEANORDNING**
- (56) Fremdragne publikationer:  
**EP-A- 1 018 854**  
**US-B1- 6 272 229**



# DESCRIPTION

## Field of the Invention

[0001] The present invention generally relates to a listening device, and more particularly relates to a method for equalizing output signals from a plurality of signal paths processing a plurality of sound signals in a listening device, including hearing aids and headsets, speech recognition front-ends and hands-free telephony systems.

## Background of the Invention

[0002] The background of the invention is described with particular reference to the field of directional hearing aid, where the present invention is applied, although not exclusively.

[0003] Conventionally, hearing aids utilize two microphones spaced apart at a predetermined short distance in order to capture an incoming sound signal. Such devices are often referred to as a directional hearing aid since the subsequent processing of the two audio inputs results in a better directionality perception by the user of the hearing aid. Similar techniques are applied in a number of applications where there is spatial separation between the desired signal and noise sources. Examples include headsets, speech recognition systems and hands-free telephony in automobiles.

[0004] In FIG. 1, there is shown a schematic representation of a prior art hearing aid, which is generally denoted by a reference numeral 10. As depicted in FIG. 1, the device includes two microphones 11 a and 11 b, two amplifiers 12a and 12b, two analog-to-digital (A/D) converters 13a and 13b, a combiner 15, a digital signal processor (DSP) 16, a digital-to-analog (D/A) converter 17, and a loud speaker 18, which are successively connected. In operation, a sound signal coming from a surrounding environment, for example, from a person to whom a user of the device speaks, is captured by the microphone 11 a, in which the sound signal is converted to an electrical analog signal. The electrical analog signal is input to the amplifier 12a, where the analog signal is amplified to a higher specific level. Subsequently, the amplified analog signal is converted to a digital representation (a digital signal) of the sound signal in the A/D converter 13a. Similarly, the other signal path, consisting of the microphone 11b, the amplifier 12b, and the A/D converter 13b, performs the same operation as above to produce another digital representation (digital signal) of the sound signal. The two digital signals are then processed in the combiner 15 where the two digital signals are combined into one single signal. The output signal of the combiner 15 may be further processed in the DSP (digital signal processor) 16 where, for example, the signal is filtered or further amplified according to the specific requirements of the application. Alternatively, the combiner 15 can be incorporated into the DSP 16 such that the signal combining can be done in the DSP.

[0005] Finally, the amplified and processed digital signal is converted back to an electrical analog signal in the digital-to-analog converter 17 and then converted into sound waves through the loud speaker 18, or applied directly to another systems as an electrical system from the output of the digital-to-analog converter 17.

[0006] With the hearing aid noted above, however, use of matched microphones is required in order to perform a satisfactory directionality enhancement through combination and processing of the two audio signals. In this context, the matched microphones mean that they have equal transfer functions and thus equal magnitude and phase responses in a specified frequency range. The concept of matched microphones will be further described in greater detail in conjunction with the description of the preferred embodiments of the present invention.

[0007] Currently, the provision of matched microphones has been attempted by using microphone pairs that have been matched by a microphone manufacturer. That is, the microphone manufacturer produces a number of microphones, followed by pairing of the microphones that have similar magnitude and phase response. The manual handling of the microphones affects their properties, and prevents automation of the manufacturing process. Also, additional costs are incurred in the attempt to match the microphones, though they are only matched within a specified tolerance.

[0008] Oticon A/S (EP-A-1 018854) discloses a method and system for separating target and noise signals from two input directional microphones. The signals from the directional microphones are processed using a separation algorithm in a digital signal processor. Oticon A/S does not address matching the microphones.

[0009] Baekgaard (US-B1- 6 272229) addresses the technical problem of matching of input microphones and employs the

technique of adaptive phase matching of the microphone signals.

**[0010]** Also, US Patent Nos. 4,142,072 and 5,206,913 disclose microphone matching technologies.

**[0011]** However, none of current methods are expected to be satisfactorily successful.

**[0012]** Therefore, there is a need to solve the problems noted above and also a need for an innovative approach to replace the prior art.

### **Summary of the Invention**

**[0013]** According to one aspect of the invention, there is provided a method for equalizing output signals from a plurality of signal paths in a listening device. The method comprises steps of: (a) identifying a transfer function for each of the signal paths, (b) determining a filtering function for, each signal path such that a product of the transfer function and the filtering function is a selected function, and (c) applying the filtering function to the corresponding signal path, thereby correcting the transfer function of the signal path to the selected function to equalize the output signals from the signal paths.

**[0014]** The selected function may be the transfer function for one of the plurality of signal paths. The filtering function may be set to a selected common factor.

**[0015]** In one embodiment, the step of applying the filtering function comprises steps of: (a) providing a filter means to the signal path and (b) applying the filtering function to the filter means of its corresponding signal path, thereby equalizing output signals from the filter means of the signal paths.

**[0016]** In another embodiment, the step of identifying a transfer function comprises steps of: (a) providing a sample signal to the signal path to produce a sample output signal through the signal path and (b) processing the sample signal and the sample output signal to identify the transfer function for its corresponding signal path.

**[0017]** The signal path comprises (a) a microphone for converting a sound signal to an electrical analog signal; and (b) an analog-to-digital converter coupled to the microphone for converting the electrical analog signal into a digital signal, wherein the step of identifying a transfer function comprises steps of: (a) providing a noise sample to the microphone to produce a sample output signal through the signal path and (b) processing the noise sample and the sample output signal to identify the transfer function of its corresponding signal path. The transfer function of the signal path may be a transfer function of the microphone of each signal path.

**[0018]** The step of identifying a transfer function comprises steps of: (a) acoustically providing a noise sample to the microphone with a propagation time delay to produce a first output processed through the signal path, (b) providing a second output corresponding to the noise sample with the propagation time delay, and (c) processing the first output and the second output to identify the transfer function of its corresponding signal path. The propagation delay time is selected to be integer multiple of the noise sample.

**[0019]** The step of providing the noise sample comprises steps of: (a) providing a first digital noise signal, and (b) converting the first digital noise signal into the noise sample. The step of providing a second output comprises steps of: (a) providing a second digital noise signal, the second digital noise signal being synchronized with the first digital noise signal and having properties corresponding to the first digital noise signal, (b) delaying the second digital noise signal by same amount of time as the propagation delay time, and (c) compensating the conversion factor of the first digital noise signal into the noise sample.

**[0020]** The first and second digital noise signals are provided by a maximum length sequence generator. The first and second noise signals comprise a white noise signal or a random noise signal.

**[0021]** According to another aspect of the invention, there is provided an apparatus for equalizing output signals from a plurality of signal paths in a listening device. The apparatus comprises: (a) means for identifying a transfer function for the signal path, (b) means for determining a filtering function for the signal path such that a product of the transfer function and the filtering function is a selected function, and (c) means for applying the filtering function to its corresponding signal path, thereby correcting the transfer function of the signal path to the selected function to equalize the output signals from the signal paths.

[0022] The selected function may be the transfer function for one of the signal paths. The filtering function can be a common factor.

[0023] In one embodiment, the filtering function applying means comprises: (a) a filter means provided to the signal path, and (b) means for applying the filtering function to the filter means of its corresponding signal path, thereby equalizing output signals from the filter means of the signal paths.

[0024] In another embodiment, the transfer function identifying means comprises: (a) means for providing a sample signal to the signal path to produce a sample output signal through the signal path, and (b) means for processing the sample signal and the sample output signal to identify the transfer function for its corresponding signal path.

[0025] The signal path comprises (a) a microphone for converting a sound signal to an electrical analog signal; and (b) an analog-to-digital converter coupled to the microphone for converting the electrical analog signal into a digital signal, wherein the transfer function identifying means comprises: (a) means for providing a noise sample to the microphone to produce a sample output signal through the signal path, and (b) means for processing the noise sample and the sample output signal to identify the transfer function of its corresponding signal path. The transfer function of the signal path may be a transfer function of the microphone.

[0026] The transfer function identifying means comprises: (a) means for acoustically providing a noise sample to the microphone with a propagation time delay to produce a first output processed through the signal path, (b) means for providing a second output corresponding to the noise sample with the propagation time delay, and (c) means for processing the first output and the second output to identify the transfer function of its corresponding signal path. The propagation delay time is selected to be integer multiple of the first noise sample.

[0027] The noise sample providing means comprises: (a) means for generating a first noise signal, and (b) means for converting the first digital noise signal into the noise sample. The second output providing means comprises: (a) means for generating a second digital noise signal, the second digital noise signal being synchronized with the first digital noise signal and having properties corresponding to the first digital noise signal; (b) means for delaying the second digital noise signal by same amount of time as the propagation delay time; and (c) means for compensating the conversion factor of the first digital noise signal into the noise sample. The converting means includes a digital-to-analog converter and in some applications, a loud speaker.

[0028] The first and second digital noise signal providing means are a maximum length sequence generator.

[0029] The first and second digital noise signals are a white noise signal or a random noise signal.

[0030] The first and second digital noise signals can be provided by a single source.

[0031] Embodiments of the invention include a listening device including hearing aids and headset, speech recognition system front-ends and hands-free telephony front-ends, which utilizes the methods described above and/or comprises the apparatus described above.

[0032] According to the present invention summarized above, the equalization process is carried out digitally so that absolute matching of the microphones can be accomplished. Therefore, the listening device user can get better speech intelligibility in noisy environments. Also, the equalization procedure of the invention is simply to deploy in production because the equalization is performed on the digital listening device chip by using a one button" procedure. Thus, the work and expense to match microphones can be saved.

[0033] A further understanding of the other features, aspects, and advantages of the present invention will be realized by reference to the following description, appended claims, and accompanying drawings.

## **Brief "Description of the Drawings**

[0034] Embodiments of the invention will now be described with reference to the accompanying drawings, in which:

Figure 1 is a schematic representation of a prior art hearing aid;

Figure 2a is a schematic representation of a hearing aid according to one embodiment of the invention;

Figure 2b is a schematic representation of a headset according to another embodiment of the invention;

Figure 2c is a schematic representation showing an embodiment of multiple signal paths according to the invention; and

Figure 3 is a schematic illustration of the equalizing filter means in Figures 2 and 2a.

#### **Detailed Description of the Preferred Embodiment(s)**

**[0035]** The preferred embodiment will be described with particular reference to a hearing aid and a headset, to which the present invention is principally applied, but not exclusively.

**[0036]** As one preferred embodiment of the present invention, a hearing aid using the inventive concept is schematically illustrated in FIG. 2a, where the hearing aid is generally denoted by a reference numeral 20. As depicted in FIG. 2a, the hearing aid includes two microphones 21 a and 21 b, two amplifiers 22a and 22b, two analog-to-digital (A/D) converters 23a and 23b, two equalizing filter means 30a and 30b, a combiner 25, a digital signal processor (DSP) 26, a digital-to-analog (D/A) converter 27, and a loud speaker 28, which are successively connected. The configuration of the hearing aid is similar to the prior art shown in FIG. 1, except for the equalizing filter means generally designated by reference numerals 30a and 30b, which constitute a significant concept and feature of the present embodiment of the invention and will be further described in greater detail hereinafter, particularly in conjunction with the description of FIG. 3.

**[0037]** For the convenience of the description and explanation of the invention, the signal path consisting of the microphone 21 a, the amplifier 22a and the A/D converter 23a is referred to as signal path A, and the signal path consisting of the microphone 21 b, the amplifier 22b and the A/D converter 23b as signal path B. In this embodiment, two signal paths A and B are illustrated; however, more than two signal paths may be utilized, depending upon applications of the present invention. -

**[0038]** In general operation, sound signals from a surrounding environment are converted into electrical analog signals via the microphones 21 a and 21 b respectively. Each of the analog signals is then fed to the respective amplifier 22a or 22b, where each signal is amplified to a specific level. The two amplified analog signals are converted through the respective analog-to-digital converter 23a or 23b to digital signals, which correspond respectively to a digital representation for the input of two microphones 21 a and 21 b. Subsequently, these digital signals are equalized by passing through the respective equalizing filters means 30a or 30b, which are generally denoted by a reference numeral 30. The equalizing means 30 and advantages associated with them will be further detailed below.

**[0039]** The two digital signals are then processed in the combiner 25 where the two digital signals are combined into one single signal. This combination can be performed in various ways, i.e., by delaying one input signal before subtracting both input signals, or by applying more complicated directional processing methods. The output signal of the combiner 25 may be further processed in the DSP (digital signal processor) 26, where, for example, the signal is filtered or further amplified according to the specific requirements of the application of the invention, including the hearing loss of a user. Finally, the amplified and processed digital signal is converted back to an electrical analog signal in the digital-to-analog converter 27 and then converted into sound waves through the loud speaker 28.

**[0040]** Alternatively, the DSP 26 can be replaced by an oversampled weighted-overlap add (WOLA) filterbank or a general purpose DSP core, which are described in US Patents Nos. 6,236,731 and 6,240,192 respectively. The disclosures of the patents are incorporated herein by reference thereto.

**[0041]** In order to facilitate the understanding of the present invention, the concept of a transfer function of a microphone or a signal path, matched and unmatched microphones, and the signal equalization will be described before disclosing the inventive concept of the equalizing filter means. A microphone converts an audio signal into an electrical signal. However, different microphones respond differently to the audio signal.

**[0042]** Thus, the conversion from the audio domain to the electrical domain can be represented in terms of a transfer function or a filtering function. Together with the different magnitude response, a phase difference between the audio signal at the microphone inlet and the electrical output signal is also part of the transfer function due to the fact that the phase lag varies with the frequency.

**[0043]** Within the microphone pass band, the attenuation and the time lags at the different frequencies are described in terms of a magnitude response and a phase response respectively of the microphone transfer function. As will be understood to those skilled in the art, the same idea will be applied to a signal circuit, for example, to the signal paths A and B as shown in FIG. 2a. In this embodiment of FIG. 2a, therefore, the transfer functions of the two microphones 21 a and 21 b may be described as M1 and M2 respectively. Also, the magnitude term is described as mag(M1) and mag(M2) and the phase term as ph(M1) and ph(M2) respectively. Consequently, in the frequency region of interest, the criteria of matched microphones can be defined as:

"A microphone 1 and a microphone 2 are said to be matched if M1 is equal to M2, i.e., mag(M1) is equal to mag(M2) and ph(M1) is equal to ph(M2)."

**[0044]** In the prior art, they have been approximately matched. Thus, the above criteria of matched microphones could not be met in the prior art.

**[0045]** The equalizing filter means 30a and 30b in FIG. 2a provide a solution to the problems in the prior art noted above. Referring to FIG. 2a, the concept of the equalizing filter means is explained below. Firstly, the transfer functions (M1 and M2) of the microphones 21 a and 21 b are identified, and secondly filtering functions (H1 and H2) are determined so that the overall transfer function between the inlet of the microphone and the output of the equalizing filter means can be equal to a certain selected function (F) for every individual microphone or signal path, which is generally represented by the following equation:

$$\begin{aligned}
 M1 * H1 &= F \\
 M2 * H2 &= F \\
 M3 * H3 &= F & (1) \\
 &: \\
 &: \\
 Mn * Hn &= F,
 \end{aligned}$$

where n is the number of microphones or signal paths as illustrated in FIG. 2c.

**[0046]** Therefore, each filtering function (H1, H2, H3,....., Hn) can be readily determined by dividing each equation with the transfer functions (M1, M2, M3,....., Mn), which have been identified in the previous step. As will be understood by those skilled in the art, the transfer functions M1 and M2 may be identified for a signal path, for example, the signal paths A and B in FIG. 2a. Thus, in the embodiment of FIG. 2a, by applying the filtering function H1 and H2, the two output signals from the equalizing filter means are shaped in an identical way even though they might have been shaped differently by the two unmatched microphones 21 a and 21 b, or by the two signal paths A and B.

**[0047]** Alternatively, the selected function (F) can be set up to a common factor A for the convenience of subsequent computations, which can be generally represented by the following equations:

$$\begin{aligned}
 M1 * H1 &= A \\
 M2 * H2 &= A \\
 M3 * H3 &= A & (2) \\
 &: \\
 &: \\
 Mn * Hn &= A,
 \end{aligned}$$

where n is the number of microphones or the number of signal paths. Therefore, each filtering function (H1, H2, H3,....., Hn) can be readily determined According to the equation (1) or (2) by using the transfer functions (M1, M2, M3,....., Mn). which have been identified in the previous step.

**[0048]** FIG. 3 depicts an embodiment of the equalizing filter means in accordance with the present invention. For the convenience of the description, although one equalizing filter means 30a for the signal path A is illustrated in FIG. 3, the same configuration can be applied to every signal path. As noted above, the equalizing filter means of the invention, in general, comprises two major functional components, one is means for identifying a transfer function (M) of the signal path to which the corresponding equalizing filter means is coupled, and the other is means for determining a filtering function (H) so that a whole transfer function of the signal path after being processed by the equalizing means become a certain constant function. The transfer function (M) of the signal path can be a transfer function of a microphone in the respective signal path.

**[0049]** As shown in FIG. 3, in this embodiment, the equalizing filter means 30a is coupled to the microphone 21a, the amplifier 22a, and the analog-to-digital converter 23a, which are from the signal path A in FIG. 2a. The equalizing filter means 30a comprises a first noise source 31, a second noise source 32, a synchronizer 33 for the first and second noise sources 31 and 32, a compensation filter 43, a delay block 34, and an identification block 35, a coefficient determination block 36, and an equalization filter 37. In FIG. 3, except for the coefficient determination block 36 and the equalization filter 37, all the elements which are bounded by a dot line C constitute the means for identifying a transfer function (M), which is one of two major functional components as noted above. The two remaining elements, the coefficient determination block 36 and the equalization filter 37, are corresponding to the means for determining a filtering function (H) depending upon the transfer function (M) identified by the previous means.

**[0050]** The first and second noise sources 31 and 32 may include an MLS (Maximum Length Sequence) generator. The MLS generator is a noise generator which generates white noise or random noise in a controlled and predictable way; see T.Schneider, D.G. Jamieson, "A Dual channel MLS-Based Test System for Hearing-Aid Characterization", J. Audio Eng. Soc, Vol. 41, No. 7/8, 1993 July/August, p583-593, the disclosure of which is incorporated herein by reference thereto. Ideally This MLS noise has an equal magnitude at all frequencies. Also, the fact that the noise can be generated in a controlled way means that the random noise is always the same on a sample-by-sample basis. Therefore, it is possible to have two or more noise generators, i.e., MLS generators, produce the exact same noise sample at different instants in time although the noise is said to be randomly distributed. In alternate, one common noise generator can be used for both the first and second noise sources 31 and 32.

**[0051]** All the elements in FIG. 3 work in combination to achieve the desired purpose of the equalizing means. That is, all the output signals from the equalization filter 30 remain constant for every signal path, so that they can have the same characteristics, for example, the same magnitude and phase response as if they were coming from a pair of ideally matched microphones. As illustrated in FIG. 3, the first noise source comprises a noise generator 31 a for generating a first noise signal and a loud speaker 31 b coupled to the noise generator 31 a for converting the noise signal into the first noise sample. The loud speaker 31 b has a known transfer function, and acoustically connected to the microphone 21 a with a propagation delay time (T), as noted by a dotted arrow D. Therefore, when the first noise samples from the loud speaker 31 b travels to the microphone 21 a, they are delayed by the delay time (T). The propagation delay time (T) is the time it takes for the first noise samples to propagate through air from the loud speaker 31 b to the microphone 21 a. Preferably, the delay time (T) may be selected to be integer multiple of the first noise sample, so that subsequent computations can be simplified. Then, the first noise sample is successively converted into an electrical analog signal, an amplified signal, and a digital signal via the microphone 21 a, the amplifier 22a, and the analog-to-digital converter respectively. Finally, the digital signal for the first noise sample, which represents an output in a digital form from the microphone 21a, is input to the identification method 35 as a first input signal.

**[0052]** Referring to FIG. 3, the second noise source 32 produces a second noise signal as the second noise sample. The second noise signal is synchronized with the first noise signal by the synchronizer 33, and has the same signal properties as the first noise signal, so that two signals are identical at any instant in time. The second noise signal is compensated through the compensation filter 43 for the conversion factor (i.e., the known transfer function of the loud speaker 31 b) of the first noise signal by the loud speaker 31 b, then, delayed by the same amount of time as the above propagation delay time (T) through the delay block 34, and input to the identification block 35 as a second input signal. This second input signal can represent an input in a digital form to the microphone 21 a since the amplifier 22a and the A/D converter 23a have flat frequency responses in the frequency interval of interest.

**[0053]** Subsequently, the two input signals are processed to identify an unknown transfer function (M) of the microphone 21 a by the identification block 35. In this embodiment, the transfer function can be estimated in terms of an Auto Regressive Moving Average (ARMA); see "Digital Signal Processing", Richard A. Roberts, Clifford T. Mullis, ISBN 0-201-16350-0, pg. 486-487 , the disclosure of which is incorporated herein by reference thereto. That is, a mode, which contains both poles and zeroes, is of the form described in the following equation in case of z-domain:

$$M(z) = \frac{\sum_{n=0}^{N-1} b_n z^{-n}}{1 + \sum_{n=1}^{N-1} a_n z^{-n}} \quad (3)$$

**[0054]** In the above equation (3), the coefficients b and a can be estimated in various ways, for example, by using error minimization methods. In this embodiment, the Steiglitz McBride method may be used, but other method may also be applicable.

The outcome of the identification block 35 is the coefficients  $b$  and  $a$ , which represent an estimate of the transfer function of the microphone 21a.

[0055] Once the transfer function  $M$  of the microphone or the signal path has been estimated as shown in the equation (3), the filter function  $H$  can be determined through the coefficient determination block 36, where a new set of coefficients for the filter function  $H$  are calculated according to the equations (1) or (2). The new coefficients are input to the equalization filter 37.

[0056] As another preferred embodiment of the present invention, a headset using the inventive concept is schematically illustrated in FIG. 2b, where the headset is generally denoted by a reference numeral 20A. As depicted in FIG. 2b, the headset further includes an adjustment filter 30c, in addition to all the components in the hearing aid illustrated in FIG. 2a. The operations of the components in FIG. 2b are identical to those in FIG. 2a, except for that of the adjustment filter 30c.

[0057] In the adjustment filter 30c of the headset 20A, an equalized signal provided by the equalization filter 30b (i.e., from the signal path B) is further processed according to applications of the headset. That is, the phase from the signal path B can be precisely changed relative to the signal path A, such that subsequent combination of the two signals can result in optimal speech intelligibility from any directions rather than in front of the headset user as in the hearing aid. For example, this headset can be used by a driver in a car where the driver talks to a person on the back seat, or by a pilot in a plane where the pilot talks to a co-pilot next to him.

[0058] It is noted that the equalizing filter means of Fig. 3 can be embodied as standalone equipment for determining equalizing coefficients and providing them to an equalization filter, thereby equalizing a plurality of signals from a plurality of signal paths. That is, the equipment comprises all elements of Fig. 3 except for the microphone 21 a, the amplifier 22a, the A/D converter 23a, and the equalization filter 37. In operation of the equipment, for example, the hearing aid 20 of Fig. 2a or the headset 20A of Fig. 2b can be provided with equalization filters F1 and F2 (like the equalization filter 37 in Fig. 3) instead of the whole filter means H1 and H2. Then, by using the standalone equipment, appropriate coefficients for each equalization filter F1 and F2 can be determined according to the same operation and procedures as noted above in conjunction with the previous embodiment of Fig.3, and stored in the hearing aid or the headset. Therefore, these coefficients are loaded into the filter when the hearing aid and headset are switched on by the end users.

[0059] While the present invention has been described with reference to specific embodiments, the description is illustrative of the invention and is not to be construed as limiting the invention. Various modifications may occur to those skilled in the art without departing from the true spirit and scope of the invention as defined by the appended claims. For example, the present invention can apply to spatial processing as well.

## REFERENCES CITED IN THE DESCRIPTION

This list of references cited by the applicant is for the reader's convenience only. It does not form part of the European patent document. Even though great care has been taken in compiling the references, errors or omissions cannot be excluded and the EPO disclaims all liability in this regard.

### Patent documents cited in the description

- [EP1018854A \[0008\]](#)
- [US6272229B1 \[0009\]](#)
- [US4142072A \[0010\]](#)
- [US5206913A \[0010\]](#)
- [US6236731B \[0040\]](#)
- [US6240192B \[0040\]](#)

### Non-patent literature cited in the description

- **T.SCHNEIDER**,**G. JAMIESON**A Dual channel MLS-Based Test System for Hearing-Aid CharacterizationJ. Audio Eng. Soc, 1993, vol. 41, 7/8583-593 [0050]
- **RICHARD A. ROBERTS****CLIFFORD T. MULLIS**Digital Signal Processing, 486-487 [0053]

PATENTKRAV

1. Fremgangsmåde til udligning af udgangssignaler fra et antal signalveje, hvilken fremgangsmåde omfatter:
- 5
- (a) identificering af en overføringsfunktion for hver af signalvejene;
- (b) bestemmelse af en filtreringsfunktion for hver signalvej, således at et produkt af overføringsfunktionen og filtreringsfunktionen er en udvalgt funktion; og
- 10
- (c) anvendelse af filtreringsfunktionen til den tilsvarende signalvej, hvorved signalvejens overføringsfunktion korrigeres til den valgte funktion for at udligne udgangssignalerne fra signalvejene,
- 15
- hvori signalvejen omfatter (a) en mikrofon til at konvertere et lydsignal til et elektrisk, analogt signal; og (b) en analog-til-digital-konverter, der er koblet til mikrofonen til konvertering af det elektriske, analoge signal til et digitalt signal, hvori trinnet med identificering omfatter trinnene med:
- 20
- (a) akustisk tilvejebringelse af en støjprøve til mikrofonen med en transmissionsforsinkelse for at frembringe et første output behandlet via signalvejen;
- (b) tilvejebringelse af et andet output svarende til støjprøven med transmissionsforsinkelsen; og
- 25
- (c) behandling af det første output og det andet output for at identificere overføringsfunktionen for den tilsvarende signalvej.
2. Fremgangsmåde ifølge krav 1, hvori den udvalgte funktion er overføringsfunktionen for én af antallet af signalveje.
- 30
3. Fremgangsmåde ifølge krav 1, hvori filtreringsfunktionen er bestemt, således at et produkt af overføringsfunktionen og filtreringsfunktionen er en udvalgt fælles faktor.

4. Fremgangsmåde ifølge krav 1, hvori trinnet med anvendelse af hver filtreringsfunktion omfatter trinnene med:
- 5
- (a) tilvejebringelse af et filtermiddel til signalvejen; og
  - (b) anvendelse af filtreringsfunktionen til den tilsvarende signalvejs filtermiddel, hvorved udgangssignalerne fra signalvejenes filtermiddel udlignes.
5. Fremgangsmåde ifølge krav 1, hvori trinnet med identificering af omfatter trinnene med:
- 10
- (a) tilvejebringelse af et prøvesignal til signalvejen for at frembringe et prøveudgangssignal via signalvejen; og
  - (b) behandling af prøvesignalet og prøveudgangssignalet for at identificere overføringsfunktionen for den tilsvarende signalvej.
- 15
6. Fremgangsmåde ifølge krav 1, hvori signalvejen omfatter (a) en mikrofon til at konvertere et lydssignal til et elektrisk, analogt signal; og (b) en analog-til-digital-konverter, der er koblet til mikrofonen til konvertering af det elektriske, analoge signal til et digitalt signal, hvori trinnet med identificering af omfatter trinnene med:
- 20
- (a) tilvejebringelse af en støjprøve til mikrofonen for at frembringe et prøveudgangssignal via signalvejen; og
  - (b) behandling af støjprøven og prøveudgangssignalet for at identificere overføringsfunktionen for den tilsvarende signalvej.
- 25
7. Fremgangsmåde ifølge krav 1, hvori trinnet med tilvejebringelse af støjprøven omfatter trinnene med:
- 30
- (a) tilvejebringelse af et første digitalt støjsignal, og
  - (b) konvertering af det første digitale støjsignal til støjprøven.

8. Fremgangsmåde ifølge krav 7, hvori trinnet med tilvejebringelse af et andet output omfatter trinnene med:
- 5
- (a) tilvejebringelse af et andet digitalt støjsignal, hvilket andet digitalt støjsignal er synkroniseret med det første digitale støjsignal og har egenskaber, der svarer til det første digitale støjsignal;
- 10
- (b) udsættelse af det andet digitale støjsignal med det samme tidsrum som transmissionsforsinkelsen; og
- (c) kompensering for det første digitale støjsignals konverteringsfaktor i støjprøven.
9. Fremgangsmåde ifølge krav 6, hvori signalvejens overføringsfunktion kan være en overføringsfunktion for mikrofonen.
- 15
10. Fremgangsmåde ifølge krav 1, hvori transmissionsforsinkelsen (T) er udvalgt til at være et helt multiplum af støjprøven.
- 20
11. Fremgangsmåde ifølge krav 7, hvori det første digitale støjsignal er tilvejebragt ved hjælp af en generator af maksimal sekvenslængde.
12. Fremgangsmåde ifølge krav 8, hvori det andet digitale støjsignal er tilvejebragt ved hjælp af en generator af maksimal sekvenslængde.
- 25
13. Fremgangsmåde ifølge krav 8, hvori det første og andet støjsignal omfatter et hvidt støjsignal.
14. Fremgangsmåde ifølge krav 8, hvori det første og andet støjsignal omfatter et vilkårligt støjsignal.
- 30
15. Apparat til udligning af udgangssignaler fra et antal signalveje, hvilket apparat omfatter:
- (a) et middel til at identificere en overføringsfunktion hver af signalvejene;
- (b) et middel til bestemmelse af en filtreringsfunktion for hver signalvej, således at et produkt af overføringsfunktionen og filtreringsfunktionen er en udvalgt funktion; og
- 35

- (c) et middel til anvendelse af filtreringsfunktionen til den tilsvarende signalvej, hvorved signalvejens overføringsfunktion korrigeres til den valgte funktion for at udligne udgangssignalerne fra signalvejene,
- 5 hvori signalvejen omfatter (a) en mikrofon til at konvertere et lydsignal til et elektrisk, analogt signal; og (b) en analog-til-digital-konverter, der er koblet til mikrofonen til konvertering af det elektriske, analoge signal til et digitalt signal, hvori midlet til identificering af overføringsfunktionen omfatter:
- 10 (a) et middel til akustisk tilvejebringelse af en støjprøve til mikrofonen med en transmissionsforsinkelse for at frembringe et første output behandlet via signalvejen;
- (b) et middel til tilvejebringelse af et andet output svarende til støjprøven med transmissionsforsinkelsen; og
- 15 (e) et middel til behandling af det første output og det andet output for at identificere overføringsfunktionen af den tilsvarende signalvej.
16. Apparat ifølge krav 15, hvori den udvalgte funktion er overføringsfunktionen for én af
- 20 signalvejene.
17. Apparat ifølge krav 15, hvori filtreringsfunktionen er bestemt således, at et produkt af overføringsfunktionen og filtreringsfunktionen er en fælles faktor.
- 25 18. Apparat ifølge krav 15, hvori midlet til anvendelse af filtreringsfunktionen omfatter:
- (a) et filtermiddel tilvejebragt til signalvejen; og
- (b) et middel til anvendelse af filtreringsfunktionen til den tilsvarende signalvejs filtermiddel,
- 30 hvorved udgangssignalerne fra signalvejenes filtermiddel udlignes.
19. Apparat ifølge krav 15, hvori midlet til identificering af overføringsfunktionen omfatter:
- (a) et middel til tilvejebringelse af et prøvesignal til signalvejen for at frembringe et
- 35 prøveudgangssignal via signalvejen; og

- (b) et middel til behandling af prøvesignalet og prøveudgangssignalet for at identificere overføringsfunktionen for den tilsvarende signalvej.
- 5 20. Apparat ifølge krav 15, hvori signalvejen omfatter (a) en mikrofon til at konvertere et lydsignal til et elektrisk, analogt signal; og (b) en analog-til-digital-konverter, der er koblet til mikrofonen til konvertering af det elektriske, analoge signal til et digitalt signal, hvori midlet til identificering af overføringsfunktionen omfatter:
- 10 (a) et middel til tilvejebringelse af en støjprøve til mikrofonen for at frembringe et prøveudgangssignal via signalvejen; og
- (b) et middel til behandling af støjprøven og prøveudgangssignalet for at identificere overføringsfunktionen af den tilsvarende signalvej.
- 15 21. Apparat ifølge krav 20, hvori midlet til tilvejebringelse af støjprøven omfatter:
- (a) et middel til generering af et første støjsignal; og
- 20 (b) et middel til konvertering af det første digitale støjsignal i støjprøven.
22. Apparat ifølge krav 21, hvori et middel til tilvejebringelse af et andet output omfatter:
- (a) et middel til generering af et andet digitalt støjsignal, hvilket andet digitalt støjsignal er synkroniseret med det første digitale støjsignal og har egenskaber, der svarer til det første digitale støjsignal;
- 25 (b) et middel til udsættelse af det andet digitale støjsignal med det samme tidsrum som transmissionsforsinkelsen; og
- 30 (c) et middel til kompensering for det første digitale støjsignals konverteringsfaktor i støjprøven.
23. Apparat ifølge krav 21, hvori midlet til tilvejebringelse af det første digitale støjsignal er en generator af maksimal sekvenslængde.
- 35

24. Apparat ifølge krav 21, hvori konverteringsmidlet indbefatter en digital-til-analog-konverter og en højttaler.
- 5 25. Apparat ifølge krav 22, hvori midlet til tilvejebringelse af den anden digitale støj indbefatter en generator af maksimal sekvenslængde.
26. Apparat ifølge krav 20, hvori signalvejens overføringsfunktion er en overføringsfunktion for mikrofonen.
- 10 27. Apparat ifølge krav 15, hvori transmissionsforsinkelsen er udvalgt til at være et helt multiplum af den første støjprøve.
28. Apparat ifølge krav 22, hvori det første og det andet digitale støjsignal er et hvidt støjsignal.
- 15 29. Apparat ifølge krav 22, hvori det første og det andet digitale støjsignal er et vilkårligt støjsignal.
30. Apparat ifølge krav 22, hvori det første og det andet digitale støjsignal tilvejebringes ved hjælp af en enkelt kilde.
- 20 31. Lytteanordning ved anvendelse af en fremgangsmåde ifølge et hvilket som helst af kravene 1 til 14.
32. Høreapparat ved anvendelse af en fremgangsmåde ifølge et hvilket som helst af kravene 1 til 14.
- 25 33. Headset ved anvendelse af en fremgangsmåde ifølge et hvilket som helst af kravene 1 til 14.
34. Lytteanordning, der omfatter et apparat ifølge et hvilket som helst af kravene 15 til 30.
- 30 35. Høreapparat, der omfatter et apparat ifølge et hvilket som helst af kravene 15 til 30.
36. Headset, der omfatter et apparat ifølge et hvilket som helst af kravene 15 til 30.
37. Lytteanordning, der omfatter et signaludligningsfilter, hvori filterets funktion bestemmes ved hjælp af en fremgangsmåde ifølge et hvilket som helst af kravene 1 til 14.
- 35

38. Høreapparat, der omfatter et signaludligningsfilter, hvori filterets funktion bestemmes ved hjælp af en fremgangsmåde ifølge et hvilket som helst af kravene 1 til 14.
- 5 39. Headset, der omfatter et signaludligningsfilter, hvori filterets funktion bestemmes ved hjælp af en fremgangsmåde ifølge et hvilket som helst af kravene 1 til 14.

DRAWINGS

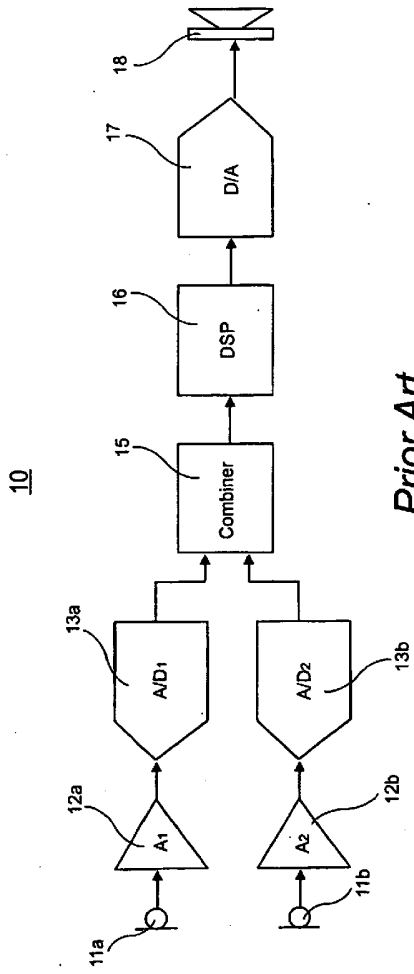

*Prior Art*  
FIG. 1

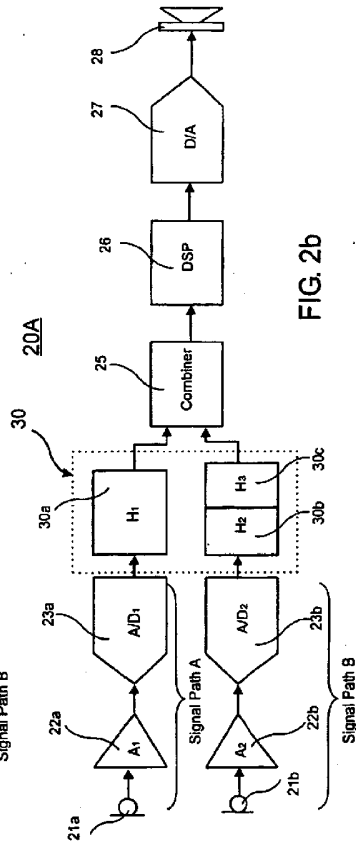
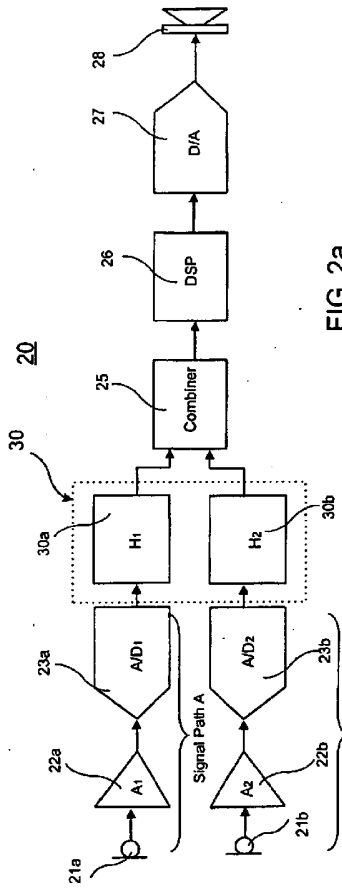

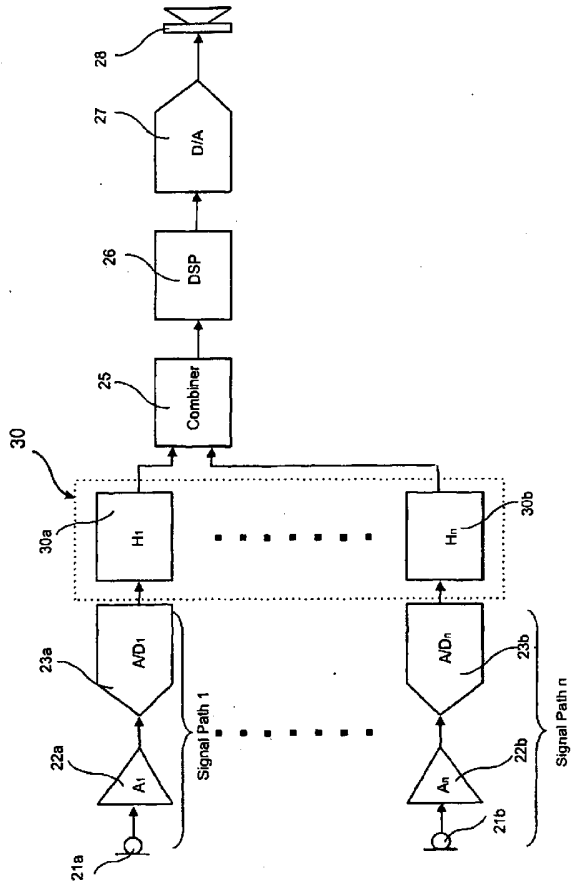

FIG. 2c

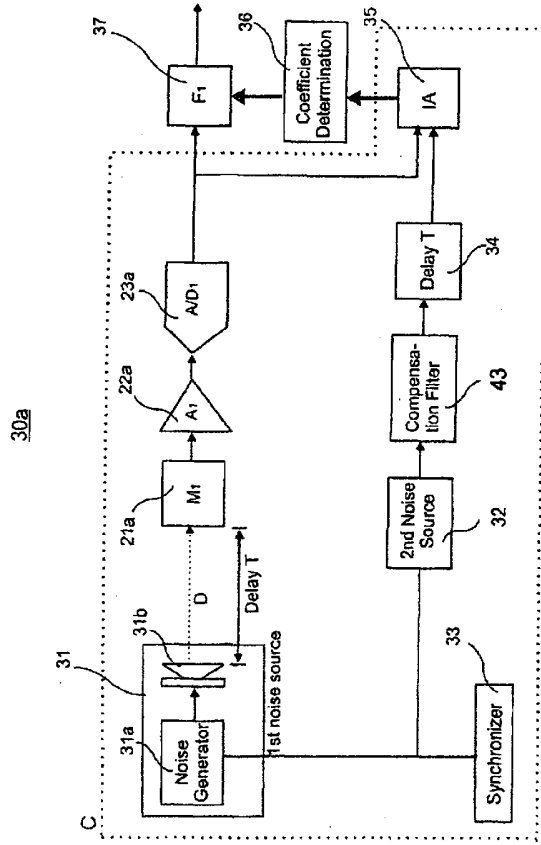

FIG.3