

(19) World Intellectual Property Organization
International Bureau



(43) International Publication Date
8 January 2009 (08.01.2009)

PCT

(10) International Publication Number
WO 2009/005308 A3

- (51) International Patent Classification:
H04N 7/24 (2006.01)
- (21) International Application Number:
PCT/KR2008/003915
- (22) International Filing Date: 2 July 2008 (02.07.2008)
- (25) Filing Language: English
- (26) Publication Language: English
- (30) Priority Data:
60/947,447 2 July 2007 (02.07.2007) US
60/957,714 24 August 2007 (24.08.2007) US
60/974,084 21 September 2007 (21.09.2007) US
10-2008-0063684 1 July 2008 (01.07.2008) KR
- (71) Applicant (for all designated States except US): LG ELECTRONICS INC. [KR/KR]; 20, Yeouido-dong, Yeongdeungpo-gu, Seoul 150-721 (KR).
- (72) Inventors; and
- (75) Inventors/Applicants (for US only): OH, Hyen O [KR/KR]; Lg Electornics Inc. Ip Group, 16 Woomyeon-Dong, Seocho-Gu, Seoul 137-724 (KR). CHOI, In Hwan [KR/KR]; Lg Electornics Inc. Ip Group, 16 Woomyeon-Dong, Seocho-Gu, Seoul 137-724 (KR). KWAK, Kook Yeon [KR/KR]; Lg Electornics Inc. Ip Group, 16 Woomyeon-Dong, Seocho-Gu, Seoul 137-724 (KR). LEE, Hyoung Gon [KR/KR]; Lg Electornics Inc. Ip Group, 16 Woomyeon-Dong, Seocho-Gu, Seoul 137-724 (KR). SONG, Won Gyu [KR/KR]; Lg Electornics Inc. Ip Group, 16 Woomyeon-Dong, Seocho-Gu, Seoul 137-724 (KR).

- (KR). KIM, Jin Woo [KR/KR]; Lg Electornics Inc. Ip Group, 16 Woomyeon-Dong, Seocho-Gu, Seoul 137-724 (KR). KIM, Byoung Gill [KR/KR]; Lg Electornics Inc. Ip Group, 16 Woomyeon-Dong, Seocho-Gu, Seoul 137-724 (KR).
- (74) Agents: KIM, Yong In et al.; KBK & Associates, 7th Floor, Hyundai Building, 175-9 Jamsil-dong, Songpa-gu, Seoul 138-861 (KR).
- (81) Designated States (unless otherwise indicated, for every kind of national protection available): AE, AG, AL, AM, AO, AT, AU, AZ, BA, BB, BG, BH, BR, BW, BY, BZ, CA, CH, CN, CO, CR, CU, CZ, DE, DK, DM, DO, DZ, EC, EE, EG, ES, FI, GB, GD, GE, GH, GM, GT, HN, HR, HU, ID, IL, IN, IS, JP, KE, KG, KM, KN, KP, KZ, LA, LC, LK, LR, LS, LT, LU, LY, MA, MD, ME, MG, MK, MN, MW, MX, MY, MZ, NA, NG, NI, NO, NZ, OM, PG, PH, PL, PT, RO, RS, RU, SC, SD, SE, SG, SK, SL, SM, SV, SY, TJ, TM, TN, TR, TT, TZ, UA, UG, US, UZ, VC, VN, ZA, ZM, ZW.
- (84) Designated States (unless otherwise indicated, for every kind of regional protection available): ARIPO (BW, GH, GM, KE, LS, MW, MZ, NA, SD, SL, SZ, TZ, UG, ZM, ZW), Eurasian (AM, AZ, BY, KG, KZ, MD, RU, TJ, TM), European (AT, BE, BG, CH, CY, CZ, DE, DK, EE, ES, FI, FR, GB, GR, HR, HU, IE, IS, IT, LT, LU, LV, MC, MT, NL, NO, PL, PT, RO, SE, SI, SK, TR), OAPI (BF, BJ, CF, CG, CI, CM, GA, GN, GQ, GW, ML, MR, NE, SN, TD, TG).

Published:
— with international search report

[Continued on next page]

(54) Title: BROADCASTING RECEIVER AND BROADCAST SIGNAL PROCESSING METHOD

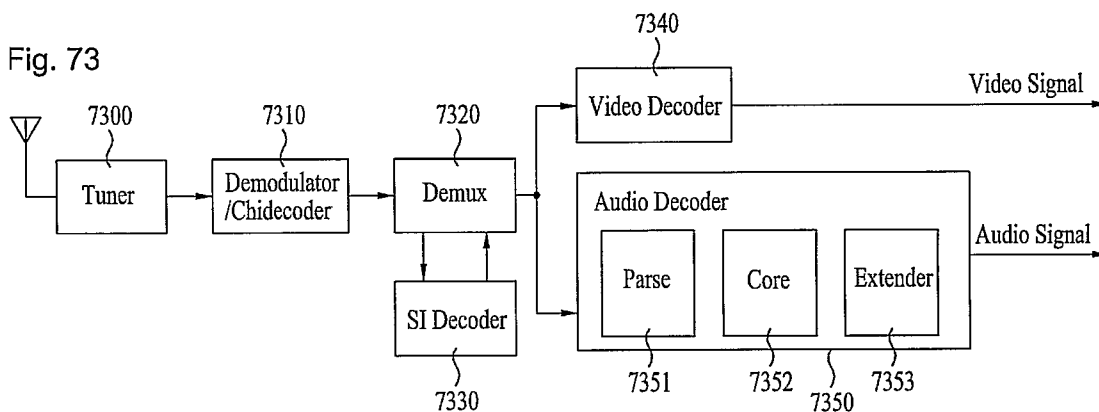

(57) Abstract: A broadcasting receiver and broadcast signal processing method are disclosed. A receiver receives a broadcast signal including mobile service data and main service data, in which the mobile service data is able to construct a data group, the data group is divided into several areas, N number of known data streams are inserted into some areas from among the several areas, and a transmission parameter is inserted between a first known data stream and a second known data stream from among the N number of known data streams. A transmission parameter detector detects the transmission parameter. A block decoder performs block-unit symbol-decoding of the mobile service data contained in the received broadcast signal on the basis of the detected transmission parameter. And a decoder extracts audio data and additional information from the symbol-decoded mobile service data, dequantizing the audio data, converts the dequantized audio data into a time-domain signal for each block according to a length of a block indicated by an identifier contained in the additional information, and restores an audio signal.

WO 2009/005308 A3



— *before the expiration of the time limit for amending the claims and to be republished in the event of receipt of amendments*

(88) Date of publication of the international search report:
26 February 2009

INTERNATIONAL SEARCH REPORT

International application No.
PCT/KR2008/003915**A. CLASSIFICATION OF SUBJECT MATTER****H04N 7/24(2006.01)i**

According to International Patent Classification (IPC) or to both national classification and IPC

B. FIELDS SEARCHED

Minimum documentation searched (classification system followed by classification symbols)

IPC 8 H04N

Documentation searched other than minimum documentation to the extent that such documents are included in the fields searched
Korean Utility models and applications for Utility Models: IPC as aboveElectronic data base consulted during the international search (name of data base and, where practicable, search terms used)
eKIPASS(KIPO internal): "broadcasting, receiver, decoder, mobile service data"**C. DOCUMENTS CONSIDERED TO BE RELEVANT**

Category*	Citation of document, with indication, where appropriate, of the relevant passages	Relevant to claim No.
A	WO 2006/065071 A1 (SAMSUNG ELECTRONICS CO., LTD.) 22 June 2006 See abstract, page 5, line 12 - page 12, line 12.	1-15
A	US 2006/0248563 A1 (LEE et al.) 2 Nov. 2006 See abstract, page 4, [0054] - page 5, [0059].	1-15
A	US 6,211,800 B1 (YANAGIHARA et al.) 3 Apr. 2001 See abstract, column 3, line 13 - column 4, line 56.	1-15

 Further documents are listed in the continuation of Box C. See patent family annex.

* Special categories of cited documents:

"A" document defining the general state of the art which is not considered to be of particular relevance

"E" earlier application or patent but published on or after the international filing date

"L" document which may throw doubts on priority claim(s) or which is cited to establish the publication date of citation or other special reason (as specified)

"O" document referring to an oral disclosure, use, exhibition or other means

"P" document published prior to the international filing date but later than the priority date claimed

"T" later document published after the international filing date or priority date and not in conflict with the application but cited to understand the principle or theory underlying the invention

"X" document of particular relevance; the claimed invention cannot be considered novel or cannot be considered to involve an inventive step when the document is taken alone

"Y" document of particular relevance; the claimed invention cannot be considered to involve an inventive step when the document is combined with one or more other such documents, such combination being obvious to a person skilled in the art

"&" document member of the same patent family

Date of the actual completion of the international search

07 JANUARY 2009 (07.01.2009)

Date of mailing of the international search report

07 JANUARY 2009 (07.01.2009)

Name and mailing address of the ISA/KR

Korean Intellectual Property Office
Government Complex-Daejeon, 139 Seonsa-ro, Seo-gu, Daejeon 302-701, Republic of Korea

Facsimile No. 82-42-472-7140

Authorized officer

CHO, Woo Yeon

Telephone No. 82-42-481-8524



INTERNATIONAL SEARCH REPORT

Information on patent family members

International application No.

PCT/KR2008/003915

Patent document cited in search report	Publication date	Patent family member(s)	Publication date
WO 2006-065071 A1	22.06.2006	CN 101080925	28.11.2007
		EP 1839439 A1	03.10.2007
		KR 10-2006-0067848	20.06.2006
		US 2006-133429 A1	22.06.2006
US 2006-248563 A1	02.11.2006	CN 1893660 A	10.01.2007
		EP 1717977 A2	02.11.2006
		JP 2006-311567	09.11.2006
		KR 20060112527 A	01.11.2006
US 6211800	03.04.2001	CN 1122273 C	24.09.2003
		CN 1188963 A	29.07.1998
		EP 0833514 A2	01.04.1998
		EP 0833514 A3	12.02.2003
		JP 10-154373 A	09.06.1998
		KR 10-1998-0024869	06.07.1998