

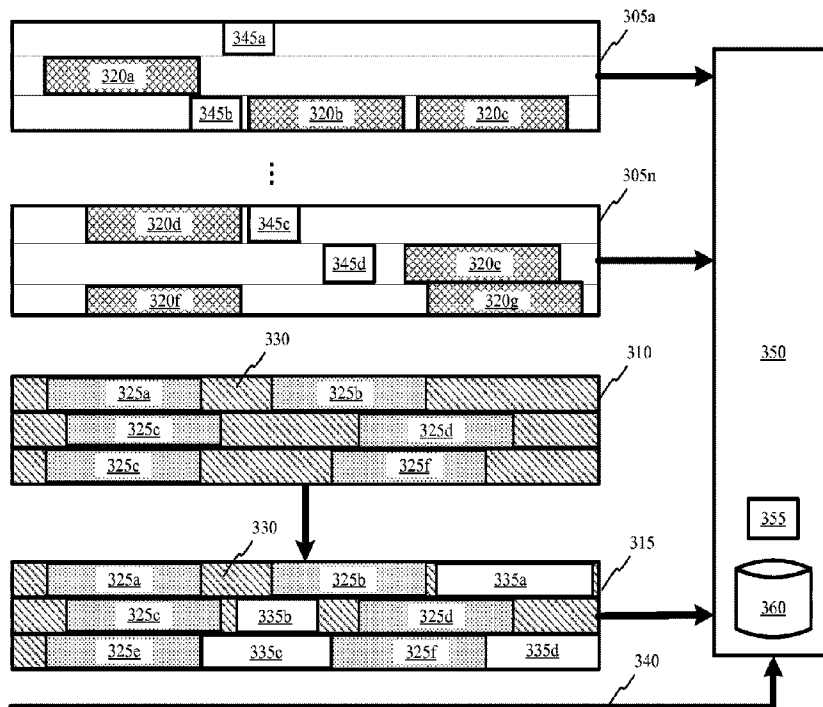

(86) Date de dépôt PCT/PCT Filing Date: 2013/08/06
 (87) Date publication PCT/PCT Publication Date: 2014/02/13
 (45) Date de délivrance/Issue Date: 2024/02/06
 (85) Entrée phase nationale/National Entry: 2015/02/03
 (86) N° demande PCT/PCT Application No.: US 2013/053822
 (87) N° publication PCT/PCT Publication No.: 2014/025804
 (30) Priorité/Priority: 2012/08/06 (US61/679,836)

(51) Cl.Int./Int.Cl. *H04N 21/647* (2011.01),
H04N 21/40 (2011.01), *H04N 21/458* (2011.01),
H04N 21/61 (2011.01), *H04N 7/10* (2006.01)
 (72) Inventeurs/Inventors:
 HABERMAN, SETH, US;
 NIEMEIJER, GERRIT, US
 (73) Propriétaire/Owner:
 FREEWHEEL MEDIA, INC., US
 (74) Agent: GOWLING WLG (CANADA) LLP

(54) Titre : SYSTEMES, PROCEDES ET SUPPORTS LISIBLES PAR ORDINATEUR POUR STOCKAGE DE CONTENU LOCAL DANS UN RESEAU MULTIMEDIA
 (54) Title: SYSTEMS, METHODS AND COMPUTER-READABLE MEDIA FOR LOCAL CONTENT STORAGE WITHIN A MEDIA NETWORK



(57) **Abrégé/Abstract:**

Systems, methods and computer-readable storage media for storing or caching targeted content on a receiver device using existing bandwidth within a media network are described. For example, unused bandwidth within a transport stream may be detected and targeted content may be inserted into the transport stream within the unused bandwidth. The targeted content may include targeted advertisements for a household addressable media network. The transport stream may be transmitted to the receiver device which may access and store the targeted content responsive to various targeted content signals. For instance, the transport stream may include targeted content signals configured to trigger the receive device to access and store the targeted content. The transport stream may include a commercial feed transport stream.

(12) INTERNATIONAL APPLICATION PUBLISHED UNDER THE PATENT COOPERATION TREATY (PCT)

(19) World Intellectual Property Organization
International Bureau



(10) International Publication Number
WO 2014/025804 A1

(43) International Publication Date
13 February 2014 (13.02.2014)

- (51) International Patent Classification:
H04N 7/10 (2006.01)
- (21) International Application Number:
PCT/US2013/053822
- (22) International Filing Date:
6 August 2013 (06.08.2013)
- (25) Filing Language: English
- (26) Publication Language: English
- (30) Priority Data:
61/679,836 6 August 2012 (06.08.2012) US
- (71) Applicant: **VISIBLE WORLD, INC** [—/US]; 460 West 34th Street, New York, New York 10001 (US).
- (72) Inventors: **HABERMAN, Seth**; 1 West 85th Street Apt. 11C, New York, New York 10024 (US). **NIEMEIJER, Gerrit**; 23 Franklin Place, Maplewood, New Jersey 07040 (US).
- (74) Agent: **HAIGHT IV, George S.**; Pepper Hamilton LLP, Suite 500, 500 Grant Street, Pittsburgh, Pennsylvania 15219-2507 (US).
- (81) Designated States (unless otherwise indicated, for every kind of national protection available): AE, AG, AL, AM, AO, AT, AU, AZ, BA, BB, BG, BH, BN, BR, BW, BY,

BZ, CA, CH, CL, CN, CO, CR, CU, CZ, DE, DK, DM, DO, DZ, EC, EE, EG, ES, FI, GB, GD, GE, GH, GM, GT, HN, HR, HU, ID, IL, IN, IS, JP, KE, KG, KN, KP, KR, KZ, LA, LC, LK, LR, LS, LT, LU, LY, MA, MD, ME, MG, MK, MN, MW, MX, MY, MZ, NA, NG, NI, NO, NZ, OM, PA, PE, PG, PH, PL, PT, QA, RO, RS, RU, RW, SA, SC, SD, SE, SG, SK, SL, SM, ST, SV, SY, TH, TJ, TM, TN, TR, TT, TZ, UA, UG, US, UZ, VC, VN, ZA, ZM, ZW.

(84) Designated States (unless otherwise indicated, for every kind of regional protection available): ARIPO (BW, GH, GM, KE, LR, LS, MW, MZ, NA, RW, SD, SL, SZ, TZ, UG, ZM, ZW), Eurasian (AM, AZ, BY, KG, KZ, RU, TJ, TM), European (AL, AT, BE, BG, CH, CY, CZ, DE, DK, EE, ES, FI, FR, GB, GR, HR, HU, IE, IS, IT, LT, LU, LV, MC, MK, MT, NL, NO, PL, PT, RO, RS, SE, SI, SK, SM, TR), OAPI (BF, BJ, CF, CG, CI, CM, GA, GN, GQ, GW, KM, ML, MR, NE, SN, TD, TG).

Published:

- with international search report (Art. 21(3))
- before the expiration of the time limit for amending the claims and to be republished in the event of receipt of amendments (Rule 48.2(h))

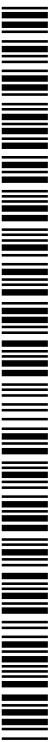

WO 2014/025804 A1

(54) Title: SYSTEMS, METHODS AND COMPUTER-READABLE MEDIA FOR LOCAL CONTENT STORAGE WITHIN A MEDIA NETWORK

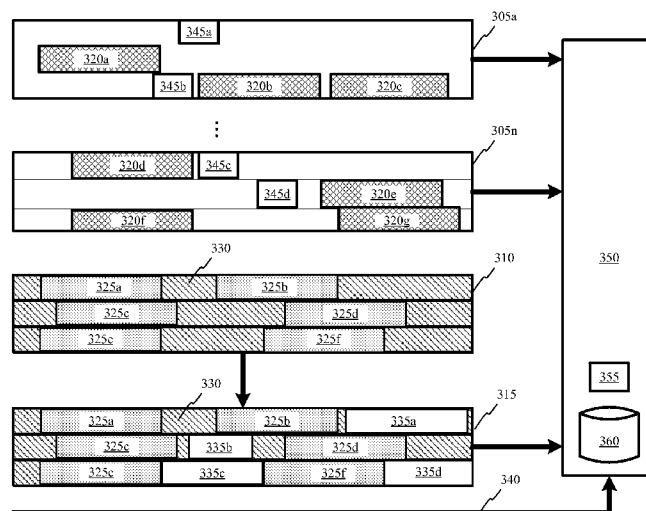

FIG. 3

(57) Abstract: Systems, methods and computer-readable storage media for storing or caching targeted content on a receiver device using existing bandwidth within a media network are described. For example, unused bandwidth within a transport stream may be detected and targeted content may be inserted into the transport stream within the unused bandwidth. The targeted content may include targeted advertisements for a household addressable media network. The transport stream may be transmitted to the receiver device which may access and store the targeted content responsive to various targeted content signals. For instance, the transport stream may include targeted content signals configured to trigger the receive device to access and store the targeted content. The transport stream may include a commercial feed transport stream.

SYSTEMS, METHODS AND COMPUTER-READABLE MEDIA FOR LOCAL CONTENT STORAGE WITHIN A MEDIA NETWORK

CROSS REFERENCE TO RELATED APPLICATIONS

[0001] This application claims the benefit of U.S. Provisional Application No. 61/679,836 filed on August 6, 2012.

FIELD OF INVENTION

[0002] The described technology generally relates to storing content at a local receiver device within a media network, and, more specifically, to the efficient use and/or configuration of available bandwidth within the media network for caching content at a local receiver device for subsequent playback by the device.

BACKGROUND

[0003] Household addressable media networks, such as cable and satellite television networks, allow network operators to provide specific content to target households. For example, an advertiser may be able to send one version of an advertisement to a first segment of households and another version of the advertisement to a second segment of households. Receiver devices, such as set-top-boxes (STB), may be configured to cache targeted content so that the targeted content may be accessed locally when a programming slot, such as an advertising slot, requires the targeted content. However, accessing and caching the targeted content is performed outside of normal content access for the receiver device, such as normal television viewing by a user. Existing technology provides for additional broadcast streams for transmitting the targeted content to the receiver devices for local storage. However, this introduces inefficiencies and extra cost into the operation of the media network due to the need

to handle extra bandwidth. Accordingly, a media network may benefit from a system in which targeted content may be provided to receiver devices for local caching without also requiring additional resources that diminish the value of targeted content within a household addressable network.

5

SUMMARY

[0004] This disclosure is not limited to the particular systems, devices and methods described, as these may vary. The terminology used in the description is for the purpose of describing the particular versions or embodiments only, and is not intended to limit the scope.

10 [0005] As used in this document, the singular forms “a,” “an,” and “the” include plural references unless the context clearly dictates otherwise. Unless defined otherwise, all technical and scientific terms used herein have the same meanings as commonly understood by one of ordinary skill in the art. Nothing in this disclosure is to be construed as an admission that the embodiments described in this disclosure are not entitled to antedate such disclosure by virtue of
15 prior invention. As used in this document, the term “comprising” means “including, but not limited to.”

[0006] In an embodiment, a system for storing at least one targeted content element on a receiver device within a household-addressable media network may include a processor and a non-transitory, computer-readable storage medium in operable communication with the
20 processor. The computer-readable storage medium may contain one or more programming instructions that, when executed, cause the processor to determine unused bandwidth in at least one transport stream being broadcast to the receiver device, insert the at least one targeted content element into the unused bandwidth, and provide a content storage signal to the receiver device to store the targeted content element.

[0007] In an embodiment, a computer-implemented method for storing at least one targeted content element on a receiver device within a household-addressable media network may include, by a processor determining unused bandwidth in at least one transport stream being broadcast to the receiver device by the media network, inserting the at least one targeted content element into the unused bandwidth, and providing a content storage signal to the receiver device to store the targeted content element.

[0008] In an embodiment, a receiver device for storing at least one targeted content element broadcast through at least one transport stream within a household-addressable media network may include a plurality of tuners configured to tune the receiver device to receive the at least one transport stream, a processor, at least one storage device in operable communication with the processor, and a non-transitory, computer-readable storage medium in operable communication with the processor. The computer-readable storage medium contains one or more programming instructions that, when executed, cause the processor to receive a content storage signal comprising targeted content information, tune at least one of the plurality of tuners to the at least one transport stream responsive to receiving the content storage signal, and store the at least one pre-stored content element in the at least one storage device based on the pre-stored content information.

[0009] In an embodiment, a computer-readable storage medium having computer-readable program code configured to store at least one targeted content element on a receiver device within a household-addressable media network. The computer-readable program code may include computer-readable program code configured to determine unused bandwidth in at least one transport stream being broadcast to the receiver device, computer-readable program code configured to insert the at least one targeted content element into the unused bandwidth, and computer-readable program code configured to provide a content storage signal to the receiver device to store the targeted content element.

[0009a] There is provided a computer-implemented method for storing at least one targeted content element on a receiver device within a household-addressable media network, the method comprising, by a processor: determining a capacity and at least one location of unused bandwidth in at least one commercial feed transport stream being transmitted to a plurality of tuners in a receiver device, the plurality of tuners configured to tune the receiver device to receive the at least one commercial feed transport stream, wherein the commercial feed transport stream comprises one or more non-targeted content elements; inserting the at least one targeted content element into the unused bandwidth of the at least one commercial feed transport stream; and inserting at least one content storage signal into at least one of a plurality of programming transport streams being transmitted to the receiver device, the at least one content storage signal being configured to instruct the receiver device to store the at least one targeted content element.

[0009b] There is provided a receiver device for storing at least one targeted content element broadcast through at least one transport stream within a household-addressable media network, the device comprising: a plurality of tuners configured to tune the receiver device to receive the at least one transport stream; a processor; at least one storage device in operable communication with the processor; and a non-transitory, computer-readable storage medium in operable communication with the processor, wherein the computer-readable storage medium contains one or more programming instructions that, when executed, cause the processor to: receive at least one commercial feed transport stream and at least one of a plurality of programming transport streams, wherein the commercial feed transport stream comprises one or more non-targeted content elements, receive at least one content storage signal via the at least one programming transport stream, the at least one content storage signal comprising targeted content information configured to instruct the receiver device to store the at least one targeted content element being broadcast in unused bandwidth of the at least one commercial feed transport stream, tune at least one of the plurality of tuners to the at least one commercial feed transport stream responsive to receiving the content storage signal while another of the plurality of tuners is tuned to the at least one of a plurality of programming transport streams, and store at least one of the at least one targeted content element in the at least one storage device based on the targeted content information.

[0009c] There is provided a method comprising: determining at least one location of unused bandwidth in at least one commercial feed transport stream, the at least one commercial feed transport stream comprising one or more nontargeted content elements; inserting at least one targeted content element into the unused bandwidth of the at least one commercial feed transport stream; and sending, in at least one programming transport stream, to a receiver device within a household-addressable media network, at least one content storage signal configured to instruct the receiver device to store the at least one targeted content element.

[0009d] There is provided a method comprising: determining unused bandwidth in one or more commercial transport streams, wherein the one or more commercial transport streams comprise one or more non-targeted content elements; determining one or more targeted content elements to send to a computing device; and sending, via a programming transport stream and to the computing device, one or more signals configured to cause the computing device to receive the one or more targeted content elements sent in the unused bandwidth, wherein the signal comprises metadata indicating information associated with the one or more targeted content elements.

[0009e] There is provided a method comprising: determining unused bandwidth in one or more content streams; determining one or more targeted content elements to send to a computing device; and sending, via to the computing device, one or more instructions to cause the computing device to receive the one or more targeted content elements in the unused bandwidth, wherein the one or more instructions comprise metadata indicating information associated with the one or more targeted content elements.

BRIEF DESCRIPTION OF THE DRAWINGS

[0010] The above and other objects of the present invention will become more readily apparent from the following detailed description taken in connection with the accompanying
5 drawings.

[0011] FIG. 1 depicts an illustrative media network according to some embodiments.

[0012] FIG. 2 depicts an illustrative receiver device configured according to an embodiment.

[0013] FIG. 3 depicts an illustrative system for providing targeted content to a receiver
10 device.

[0014] FIG. 4 depicts a block diagram of exemplary internal hardware that may be used to contain or implement the various computer processes and systems as discussed above.

DETAILED DESCRIPTION

[0015] The described technology is generally directed to systems, methods and
15 computer-readable media configured to store targeted content broadcast within a media network on a receiver device for subsequent playback on the receiver device. For example, some embodiments may provide for analyzing a transport stream, such as a commercial feed transport stream, for unused bandwidth. The targeted content may be inserted into the unused bandwidth
20 and transmitted to the receiver device. One or more targeted content signals may also be provided to the receiver device to trigger the receiver device to access and store the targeted content.

[0016] FIG. 1 depicts an illustrative media network according to some embodiments. As shown in FIG. 1, a media network **100** may include a media content provider **105**. Non-limiting
25 examples of a media content provider **105** include a television broadcast network, a cable

television network, a satellite television network, an internet service provider (ISP), a computing device advertising network, a media distribution network, a cloud computing network, a local area network (LAN), a wide area network (WAN), or any combination thereof. The media content provider **105** may transmit content to one or more local content systems **110a-110n** 5 configured to communicate with an audience **115** of the media network **100**. The local content systems **110a-110n** may include equipment and systems configured to transmit media content received from the media content provider **105** to a defined portion of the audience **115**.

Illustrative and non-restrictive examples of a local content system **110a-110n** include a cable television network headend, an internet service provider base station, or the like.

10 [0017] According to embodiments, the media content provider **105** may be configured to operate across physical device platforms and networks simultaneously. For example, content may be delivered to set-top-boxes (STBs) and/or digital video recorders (DVRs) over a cable television system, to mobile computing devices using standard network communication protocols (for instance, Ethernet or Wi-Fi) over an ISP network, to smart phone devices over 15 standard telecommunication protocols (for instance, third Generation (3G), fourth Generation (4G), long-term evolution (LTE), or the like), and to home gateway devices through a LAN, WAN and/or ISP network.

[0018] The audience **115** may include a plurality of households **120** capable of receiving media content from the media network **100** through various receiver devices, including, without 20 limitation, a STB, a television, a DVR, a personal computer (PC), a laptop computer, a mobile computing device, a smartphone, a tablet computing device, a home gateway, or the like. Although multiple households **120** are depicted in FIG. 1, only one is labeled to simplify the figure. The audience **115** may be divided into segments **125a-125n** based on various segmentation factors. Non-limiting examples of segmentation factors include age, gender, 25 occupation, years of home ownership, household size, income, geographic location, family size,

media consumption habits, and combinations thereof. For example, an audience segment may include males between the ages of 25 to 35 with an annual income above \$50,000.

[0019] According to some embodiments, the audience may be household addressable such that the media content provider **105** and/or the local content systems **110a-110n** may direct
5 particular content directly to each household **120** and/or segments **125a-125n** of the audience **115**. According to some embodiments, content may generally include any type of data capable of being received and consumed by a recipient. Illustrative and non-restrictive examples of content include advertising, entertainment programs, informational programs, messages, video, audio, graphical, and/or animated content. The media network **105** may direct particular media
10 content, such as an advertisement or a television program, only to certain segments **125a-125n**.

[0020] In an embodiment, the media content provider **105** and/or the local content systems **110a-110n** may be configured to implement linear addressable systems, such as a linear addressable television advertising system. In a linear addressable system, content may be targeted to individual household **120** receiver devices, such as STBs, home gateways, and/or
15 DVRs in a linear broadcast system. In general, a linear broadcast system may be configured to broadcast all or substantially all content (for example, programming networks) to all receiver devices within the audience **115**. Providing targeted content or targeted content elements, such as advertisements, within a linear broadcast system may require that receiver devices are able to access the targeted content during the time that the targeted content is scheduled to be shown,
20 which may generally be referred to as an “avail.”

[0021] The receiver devices may access the targeted content from various sources. In one example, the targeted content may be broadcast simultaneously with the avail through the media network **100** using a separate transmission stream. In such an example, the receiver devices may switch to the transmission stream carrying the targeted content during the avail and
25 then back to the original transmission stream (for example, a programming transport stream) to

return to the original content (for example, a television program) being accessed through the media device. According to some embodiments, the targeted content may be saved, cached, recorded, or otherwise stored on a storage device or disk accessible by the media device. In such embodiments, the media device may access the targeted content stored on the storage
5 device during the avail and then switches back to the original content after the avail has ended.

[0022] FIG. 2 depicts an illustrative receiver device configured according to an embodiment. As shown in FIG. 2, a household **215** may receive multiple transport streams **210a-210n**, **215a-215n** from a media network **205**. The household **215** may include a receiver device **235**, such as a STB, DVR, a home gateway, a television (for instance, a “Smart TV,” a
10 “Connected TV,” a “Hybrid TV,”), a computing device, or any combination thereof. In an embodiment, the transport streams may include programming transport streams **210a-210n** and commercial feed transport streams **215a-215n**. The programming transport streams **210a-210n** may be configured to transmit programming (for example, television programs) and avail slots to the receiver device **235** as well as information associated with the avails, including time
15 information, information associated with the content scheduled to fill the avail, or the like. The commercial feed transport streams **215a-215n** may be configured to transmit content, such as advertising content, that may be configured to be accessed during an avail.

[0023] The receiver device **235** may include multiple tuners **225a-225n** configured to tune the receiver device **235** to a transport stream **210a-210n**, **215a-215n**. In an embodiment, the
20 receiver device **235** may be capable of simultaneously handling multiple transport streams **210a-210n**, **215a-215n** using the multiple tuners **225a-225n**. For example, tuner **225a** may be tuned to programming transport stream **210a** that is being sent through the receiver device **235** to a display device **240** operably coupled to the receiver device for viewing by a user. Tuner **225n** may be tuned to commercial feed transport stream **210a**, which may be sending the content from

the commercial feed transport stream **215a** to a storage device **230**, such as a DVR or hard disk drive, associated with the receiver device **235**.

[0024] A media network **205** may include multiple receiver devices **235** associated with a storage device **230** as well as receiver devices that are not associated with a storage device (that is, they do not have the ability to store or cache content) that may receive targeted content. As such, the media network **205** may transmit commercial feed transport streams **215a-215n** that are time synchronized with avails within the programming transport streams **210a-210n**.

[0025] Receiving devices **235** associated with a storage device **230** may save, cache, record, or otherwise store targeted content according to various methods. In a first example according to existing technology, the targeted content may be broadcast at one or more predetermined times (for example, during low activity periods such as late night/early morning) over a commercial feed transport stream **215a-215n**. Receiver devices **235** associated with a storage device **230** may be programmed to tune to one or more of the commercial feed transport streams **210a-210n** to access and store the targeted content in the storage device. In a second example using existing technology, the targeted content may be individually transmitted to the receiver devices **235** associated with a storage device **230** for storage therein. The transmission of the targeted content in such an example may require a separate connection, such as a unicast connection. An illustrative connection may include an Internet protocol (IP) connection, for example, over DOCSIS 3.

[0026] Methods for providing targeted content for storage on a storage device **230** require additional bandwidth, for example, because they use bandwidth beyond that already allocated by the media network **205** for existing transport streams **210a-210n**, **215a-215n**. For instance, in the first example, broadcast bandwidth is required at predetermined times to transmit the targeted content and in the second example, unicast bandwidth is required. The use of additional bandwidth introduces inefficiencies and costs into the media network **205** that

diminish the benefits of providing household addressable targeted content, especially targeted advertising. Accordingly, embodiments provide methods, systems, and computer-readable media configured to, among other things, implement targeted content within a media network **205** that does not require additional bandwidth for the targeted content. For example, some
5 embodiments may use the unused bandwidth in existing transport streams **210a-210n**, **215a-215n** to transmit targeted content to receiver devices **235**. In an embodiment, the unused bandwidth in commercial feed transport streams **215a-215n** may be used to transmit targeted content to receiver devices **235**. As described in more detail below, some embodiments may use various messaging methods to communicate, schedule, or otherwise initiate the loading and
10 storage of targeted content by receiver devices **235** associated with a storage device **230**.

[0027] FIG. 3 depicts an illustrative system for providing targeted content to a receiver device. As shown in FIG. 3, multiple transport streams **305a-305n**, **310** may be broadcast, transmitted, or otherwise communicated to a receiver device **350**. The transport streams **305a-305n**, **310** may be transmitted through a media network, such as media network **100** of FIG. 1 or
15 media network **205** of FIG. 2. The receiver device **350** may include and/or be associated with a storage device **360**, such as a DVR or hard disk drive. The storage device **360** may be internal to the receiver device **350** or may be accessible through protocols known to those having ordinary skill in the art, such as Ethernet, Wi-Fi, universal serial bus (USB), serial, high-definition multimedia interface (HDMI), or the like.

[0028] The transport streams may include multiple programming transport streams **305a-305n** configured to provide programming to the receiver device **350**. For example, the programming transport streams **305a-305n** may include television programs for a receiver device **350** that is configured as or is configured to provide content to a television. The programming transport streams **305a-305n** may also include avails **320a-320g** configured for targeted content,
25 such as household addressable advertisements.

[0029] At least one commercial feed transport stream **310** may be transmitted to the receiver device **350**. The commercial feed transport stream **310** may include commercial feed content **325a-325f**, such as advertisements, that may be presented, for instance, during an avail **320a-320g**. The commercial feed transport stream **310** may include unused bandwidth **330** that does not include any content, such as the commercial feed content **325a-325f**. According to existing technology, the unused bandwidth **330** goes unutilized within the media network. According to some embodiments, the commercial feed transport stream **310** may be analyzed by computing devices, media network equipment, software, combinations thereof, or the like in order to determine where and how much unused bandwidth **330** may be present in a commercial feed transport stream **310**.

[0030] Some embodiments provided herein may be configured to insert targeted content **335a-335d** within the unused bandwidth **330** of the commercial feed transport stream **310** to generate a targeted content transport stream **315**. Illustrative and non-restrictive examples of targeted content **335a-335d** include advertising, entertainment programs, informational programs, messages, video, audio, graphical, and/or animated content. In an embodiment, the targeted content **335a-335d** includes advertisements, such as household addressable television advertisements. In this manner, some embodiments may transmit targeted content **335a-335d** to receiver devices **350** without requiring additional bandwidth, transmission equipment, network resources, or the like.

[0031] In an embodiment, all or substantially all of the unused bandwidth **330** may be filled with targeted content **335a-335d**, for instance, by providing additional targeted content **335a-335d** and/or by repeating previously broadcast targeted content, providing receiver devices **350** with targeted content that may have been missed earlier storage opportunities. According to some embodiments, the unused bandwidth **330** may be analyzed by computing devices, media network equipment, software, combinations thereof, or the like in order to determine the

locations and capacity of the unused bandwidth in order to properly populate the unused bandwidth with targeted content **335a-335d**.

[0032] According to some embodiments, the digital receiver **350** may include a processor configured to execute a receiver management application (“receiver application”) stored on a computer-readable medium accessible by the processor for controlling certain operations of the digital receiver. The receiver application may be configured to tune the digital receiver to a particular transport stream **305a-305n**, **310**, **315** and to access information transmitted through the transport streams, for example, in response to a signal, schedule, or the like.

[0033] In an embodiment, programs in the programming transport streams **305a-305n** may be configured to include content storage signals **345a-345d** configured to instruct the receiver application that targeted content **335a-335d** is being broadcast on the commercial feed transport stream **315** for storage in the storage device **360**. The content storage signals **345a-345d** may include various types of information, including, without limitation, transport stream identifiers (which commercial feed transport stream **315** includes the targeted content **335a-335d**), targeted content identifiers (which targeted content should be stored), targeted content start times, duration, information for handling the targeted content by the receiver device, or the like. The receiver application may use the information in the content storage signals **345a-345d** to tune the receiver device **350** to a particular commercial feed transport stream **315** to access and store particular targeted content **335a-335d**. In an embodiment where the receiver device **350** includes multiple tuners, the receiver application may be configured to tune an unused tuner (if available) to the particular commercial feed transport stream **315**. In this manner, a user may continue to watch a television program through the receiver device **350** while the receiver device is tuned to a particular commercial feed transport stream **315** to access and store targeted content **335a-335d**. In an embodiment, if a tuner is not available, the receiver application may be

configured to not tune the receiver device **350** to the commercial feed transport stream **315** and pass on the recording opportunity.

[0034] In an embodiment, an out-of-band channel **340** may be used to communicate information to the receiver device **350** for accessing and storing targeted content **335a-335d**.

5 Non-limiting examples of out-of-band channels **340** include IP communication channels, radio frequency (RF) communication channels, or the like. For instance, an STB receiver device **350** may include an IP communication channel for receiving information for accessing and storing targeted content **335a-335d**.

[0035] In an embodiment, the receiver application may access a targeted content
10 schedule **355** configured to instruct the receiver application to tune the receiver device **350** to a particular commercial feed transport stream **315** to access and store particular targeted content **335a-335d** according to a predefined schedule. According to some embodiments, the predefined schedule may be loaded in the receiver device **350** at start-up, may be loaded in the receiver
device **350** after startup through a broadcast carousel, may be loaded in the receiver through the
15 out-of-band channel **340**, may be a part of the firmware of the receiver device, or combinations thereof.

[0036] In an embodiment, information, such as metadata, associated with the targeted
content **335a-335d** may be included in the targeted content signals **345a-345d**, **340**, **355** and in
the commercial feed transport stream **315**. For example, the targeted content signals **345a-345d**,
20 **340**, **355** may include targeted content information associated with a time and location within the commercial feed transport stream **315** to be accessed by the receiver device **350**. At the defined time and location, the commercial feed transport stream **315** may include additional targeted content information, such as the transport stream identifiers, targeted content identifiers, targeted content start times, duration, or the like for the receiver device **350**. In another embodiment, the
25 additional information in the commercial feed transport stream **315** may include metadata

configured to map commercial and location identifiers from the targeted content signals **345a-345d**, **340**, **355** to actual commercial and location identifiers within the commercial feed transport stream.

[0037] Although the commercial feed transport stream **315** has been used as the carrier of targeted content **335a-335d** herein, embodiments are not so limited, as any transport stream capable of operating according to some embodiments is contemplated herein.

[0038] The receiver application and/or media network applications may be configured to provide exception handling, for instance, if the storage of targeted content **335a-335d** is interrupted. In a television network example, targeted commercials may be triggered by a cue tone message, or other suitable trigger, broadcast by the television network which may be triggered at nearly any point in time (for instance, asynchronously). The cue tone on a programming transport stream **305a-305n** may trigger a targeted avail cue tone when the media network is also broadcasting targeted content **335a-335d** through the commercial feed transport stream **315**, for example, because unused bandwidth was detected. The availability of the targeted content **335a-335d** may be communicated to the receiver device **350** through a targeted content signal **345a-345d**, **340**, **355** and the receiver device may be storing the targeted content during the cue tone. As such, the downloading of the targeted content **335a-335d** may need to be cancelled and the receiver devices **350** within the media network that were recording the targeted content may be informed to cancel the storage process. According to some embodiments, a “cancel message” (not shown) may be inserted within the commercial feed transport stream **315** responsive to a storage/avail conflict to notify the receiver devices **350** that the storage of targeted content **335a-335d** must be cancelled, after which the next targeted avail may be executed.

[0039] FIG. 4 depicts a block diagram of exemplary internal hardware that may be used to contain or implement the various computer processes and systems as discussed above. A bus

400 serves as the main information highway interconnecting the other illustrated components of the hardware. CPU 405 is the central processing unit of the system, performing calculations and logic operations required to execute a program. CPU 405, alone or in conjunction with one or more of the other elements disclosed in FIG. 4, is an exemplary processing device, computing device or processor as such terms are used within this disclosure. Read only memory (ROM) 430 and random access memory (RAM) 435 constitute exemplary memory devices.

[0040] A controller 420 interfaces with one or more optional memory devices 425 to the system bus 400. These memory devices 425 may include, for example, an external or internal DVD drive, a CD ROM drive, a hard drive, flash memory, a USB drive or the like. As indicated previously, these various drives and controllers are optional devices. Additionally, the memory devices 425 may be configured to include individual files for storing any software modules or instructions, auxiliary data, common files for storing groups of results or auxiliary, or one or more databases for storing the result information, auxiliary data, and related information as discussed above.

[0041] Program instructions, software or interactive modules for performing any of the functional steps associated with, among other things, analyzing a transport stream, inserting targeted content into a transport stream, and storing targeted data as described above may be stored in the ROM 430 and/or the RAM 435. Optionally, the program instructions may be stored on a tangible computer-readable medium such as a compact disk, a digital disk, flash memory, a memory card, a USB drive, an optical disc storage medium, such as a Blu-ray™ disc, and/or other recording medium.

[0042] An optional display interface 430 may permit information from the bus 400 to be displayed on the display 435 in audio, visual, graphic or alphanumeric format. The information may include information related to a current job ticket and associated tasks. Communication with external devices may occur using various communication ports 440. An exemplary

communication port **440** may be attached to a communications network, such as the Internet or a local area network.

[0043] The hardware may also include an interface **445** which allows for receipt of data from input devices such as a keyboard **450** or other input device **455** such as a mouse, a joystick,
5 a touch screen, a remote control, a pointing device, a video input device and/or an audio input device.

[0044] It will be appreciated that various of the above-disclosed and other features and functions, or alternatives thereof, may be desirably combined into many other different systems or applications. It will also be appreciated that various presently unforeseen or unanticipated
10 alternatives, modifications, variations or improvements therein may be subsequently made by those skilled in the art which alternatives, variations and improvements are also intended to be encompassed by the following claims.

CLAIMS:

1. A computer-implemented method for storing at least one targeted content element on a receiver device within a household-addressable media network, the method comprising, by a processor:

determining a capacity and at least one location of unused bandwidth in at least one commercial feed transport stream being transmitted to a plurality of tuners in a receiver device,

the plurality of tuners configured to tune the receiver device to receive the at least one commercial feed transport stream, wherein the commercial feed transport stream comprises one or more non-targeted content elements;

inserting the at least one targeted content element into the unused bandwidth of the at least one commercial feed transport stream; and

inserting at least one content storage signal into at least one of a plurality of programming transport streams being transmitted to the receiver device, the at least one content storage signal being configured to instruct the receiver device to store the at least one targeted content element.

2. The method of claim 1, wherein the receiver device comprises at least one of a set-top-box, a television, a computing device, or combinations thereof.

3. The method of claim 1 or 2, wherein the media network is configured as a cable television system.

4. The method of any one of claims 1-3, wherein the at least one targeted content element comprises a targeted advertisement.

5. The method of any one of claims 1-4, wherein the at least one content storage signal is inserted into an out-of-band channel.

6. The method of any one of claims 1-5, further comprising transmitting a targeted content schedule to the receiver device for scheduling storage of the at least one targeted content element by the receiver device.

7. The method of any one of claims 1-6, wherein the at least one content storage signal comprises: at least one transport stream identifier, at least one targeted content identifier, and at least one of a targeted content start time, a targeted content duration, and targeted content handling information.

8. A receiver device for storing at least one targeted content element broadcast through at least one transport stream within a household-addressable media network, the device comprising:

a plurality of tuners configured to tune the receiver device to receive the at least one transport stream;

a processor;

at least one storage device in operable communication with the processor; and

a non-transitory, computer-readable storage medium in operable communication with the processor, wherein the computer-readable storage medium contains one or more programming instructions that, when executed, cause the processor to:

receive at least one commercial feed transport stream and at least one of a plurality of programming transport streams, wherein the commercial feed transport stream comprises one or more non-targeted content elements,

receive at least one content storage signal via the at least one programming transport stream, the at least one content storage signal comprising targeted content information configured to instruct the receiver device to store the at least one targeted content element being broadcast in unused bandwidth of the at least one commercial feed transport stream,

tune at least one of the plurality of tuners to the at least one commercial feed transport stream responsive to receiving the content storage signal while another of the plurality of tuners is tuned to the at least one of a plurality of programming transport streams, and

store at least one of the at least one targeted content element in the at least one storage device based on the targeted content information.

9. The device of claim 8, wherein the at least one storage device comprises at least one of a digital video recorder and a hard disk drive.

10. The device of claim 8 or 9, wherein the device comprises is at least one of a set-top-box, a television, a computing device, or combinations thereof.

11. The device of any one of claims 8-10, wherein the media network is configured as a cable television system.

12. The device of any one of claims 8-11, wherein the at least one targeted content element comprises a targeted advertisement.

13. The device of any one of claims 8-12, wherein the content storage signal is provided through an out-of-band channel.

14. The device of any one of claims 8-13, wherein the content storage signal is provided through a targeted content schedule.

15. A method comprising:
determining at least one location of unused bandwidth in at least one commercial feed transport stream, the at least one commercial feed transport stream comprising one or more nontargeted content elements;
inserting at least one targeted content element into the unused bandwidth of the at least one commercial feed transport stream; and
sending, in at least one programming transport stream, to a receiver device within a household-addressable media network, at least one content storage signal configured to instruct the receiver device to store the at least one targeted content element.

16. The method of claim 15, further comprising transmitting a targeted content schedule to the receiver device for scheduling storage of the at least one targeted content element by the receiver device.

17. The method of claim 15 or 16, wherein the at least one content storage signal comprises an indication of a location for the receiver device to access information associated with the targeted content element.

18. The method of claim 17, wherein the information associated with the targeted content element comprises at least one of:

a transport stream identifier;

a targeted content identifier; and

a targeted content start time, a targeted content duration, and targeted content handling information.

19. The method of any one of claims 15-18, wherein the at least one targeted content element comprises a targeted advertisement.

20. The method of any one of claims 15-19, wherein the at least one content storage signal is inserted into an out-of-band channel.

21. A method comprising:

determining unused bandwidth in one or more commercial transport streams, wherein the one or more commercial transport streams comprise one or more non-targeted content elements;

determining one or more targeted content elements to send to a computing device; and

sending, via a programming transport stream and to the computing device, one or more signals configured to cause the computing device to receive the one or more targeted content elements sent in the unused bandwidth, wherein the signal comprises metadata indicating information associated with the one or more targeted content elements.

22. The method of claim 21, wherein the one or more signals are further configured to cause the computing device to store the one or more targeted content elements sent in the unused bandwidth.

23. The method of claim 21 or 22, wherein the information comprises a time and location within the one or more commercial transport streams to be accessed by the computing device.

24. The method of any one of claims 21-23, wherein the information comprises at least one of: a targeted content identifier, a targeted content start time, a targeted content duration, or targeted content handling information.

25. The method of any one of claims 21-24, wherein the one or more targeted content elements comprise an advertisement.

26. The method of any one of claims 21-25, wherein the one or more signals are sent via an out-of-band channel.

27. The method of any one of claims 21-26, wherein the information indicates a mapping between the one or more signals and the one or more targeted content elements sent in the unused bandwidth.

28. The method of any one of claims 1-7, wherein the at least one content storage signal comprises targeted content information associated with a time and location within the at least one commercial feed transport stream to be accessed by the receiver device.

29. A device comprising:
one or more processors; and
memory storing instructions that, when executed by the one or more processors, cause the device to perform the method of any one of claims 1-7 and 28.

30. A non-transitory computer-readable storage medium storing computer-readable instructions that, when executed by a processor, perform the method of any one of claims 1-7 and 28.

31. A system comprising:
a first computing device configured to perform the method of any one of claims 1-7 and 28; and

a second computing device configured to store the at least one targeted content element.

32. A device comprising:
one or more processors; and
memory storing instructions that, when executed by the one or more processors, cause the device to perform the method of any one of claims 15-20.

33. A non-transitory computer-readable storage medium storing computer-readable instructions that, when executed by a processor, perform the method of any one of claims 15-20.

34. A system comprising:
a first computing device configured to perform the method of any one of claims 15-20; and
a second computing device configured to store the at least one targeted content element.

35. A device comprising:
one or more processors; and
memory storing instructions that, when executed by the one or more processors, cause the device to perform the method of any one of claims 21-27.

36. A non-transitory computer-readable storage medium storing computer-readable instructions that, when executed by a processor, perform the method of any one of claims 21-27.

37. A system comprising:
a first computing device configured to perform the method of any one of claims 21-27; and
a second computing device configured to receive the one or more targeted content elements sent in the unused bandwidth.

38. A method comprising:

determining unused bandwidth in one or more content streams;
determining one or more targeted content elements to send to a computing device; and
sending, via to the computing device, one or more instructions to cause the computing device to receive the one or more targeted content elements in the unused bandwidth, wherein the one or more instructions comprise metadata indicating information associated with the one or more targeted content elements.

39. The method of claim 38, wherein the one or more instructions further cause the computing device to store the one or more targeted content elements received in the unused bandwidth.

40. The method of claim 38 or 39, wherein the information comprises a time and location within the one or more content streams to be accessed by the computing device.

41. The method of any one of claims 38-40, wherein the information comprises at least one of: a targeted content identifier, a targeted content start time, a targeted content duration, or targeted content handling information.

42. The method of any one of claims 38-41, wherein the one or more targeted content elements comprise an advertisement.

43. The method of any one of claims 38-42, wherein the one or more instructions are sent via an out-of-band channel.

44. The method of any one of claims 38-43, wherein the information indicates a mapping between the one or more instructions and the one or more targeted content elements sent in the unused bandwidth.

45. A device comprising:
one or more processors; and

memory storing instructions that, when executed by the one or more processors, cause the device to perform the method of any one of claims 38-44.

46. A non-transitory computer-readable storage medium storing computer-readable instructions that, when executed by a processor, perform the method of any one of claims 38-44.

47. A system comprising:
a first computing device configured to perform the method of any one of claims 38-44; and
a second computing device configured to receive the one or more targeted content elements sent in the unused bandwidth.

48. A method comprising:
determining unused bandwidth, in one or more transport streams comprising one or more content elements, that is available for insertion of one or more advertising content elements;
determining, based on audience segmentation information, an advertising content element of the one or more advertising content elements to send to a computing device; and
inserting, in the unused bandwidth, the advertising content element to cause transmission of the advertising content element to the computing device, wherein the advertising content element is associated with metadata accessible by the computing device.

49. The method of claim 48, wherein the metadata comprises information to cause the computing device to store the advertising content element.

50. The method of any one of claims 48-49, wherein the metadata comprises a time and location within the one or more transport streams.

51. The method of any one of claims 48-50, wherein the metadata comprises at least one of: an advertising content identifier, an advertising content start time, an advertising content duration, or advertising content handling information.

52. The method of any one of claims 48-51, wherein the determining the unused bandwidth, in the one or more transport streams comprising the one or more content elements, that is available for insertion of the one or more advertising content elements comprises detecting an advertising avail within the one or more transport streams.

53. The method of claim 52, wherein the advertising avail is indicated by a cue tone in the one or more transport streams.

54. The method of any one of claims 48-53, wherein computing device comprises at least one of: a set-top-box, a digital video recorder, a mobile computing device, or a smartphone.

55. A device comprising:
one or more processors; and
memory storing instructions that, when executed by the one or more processors, cause the device to perform the method of any one of claims 48-54.

56. A non-transitory computer-readable storage medium storing computer-readable instructions that, when executed by a processor, perform the method of any one of claims 48-54.

57. A system comprising:
a first computing device configured to perform the method of any one of claims 48-54; and
a second computing device configured to receive the advertising content element.

58. A method comprising:
determining unused bandwidth, in a first transport stream comprising one or more content elements, that is available for insertion of one or more advertising content elements;
determining, based on audience segmentation information, an advertising content element of the one or more advertising content elements to present to a computing device;
inserting, in the unused bandwidth, the advertising content element; and

sending, via a second transport stream, one or more signals configured to cause the computing device to access the advertising content element, wherein the one or more signals comprise metadata indicating a time and location within the first transport stream.

59. The method of claim 58, wherein the metadata further comprises information to cause the computing device to store the advertising content element.

60. The method of any one of claims 58-59, wherein the metadata further comprises at least one of: an advertising content identifier, an advertising content start time, an advertising content duration, or advertising content handling information.

61. The method of any one of claims 58-60, wherein the one or more signals indicate an advertising avail within the first transport stream.

62. The method of any one of claims 58-61, wherein the advertising avail is indicated by a cue tone associated with the one or more signals.

63. The method of any one of claims 58-62, wherein computing device comprises at least one of: a set-top-box, a digital video recorder, a mobile computing device, or a smartphone.

64. A device comprising:
one or more processors; and
memory storing instructions that, when executed by the one or more processors, cause the device to perform the method of any one of claims 58-63.

65. A non-transitory computer-readable storage medium storing computer-readable instructions that, when executed by a processor, perform the method of any one of claims 58-63.

66. A system comprising:
a first computing device configured to perform the method of any one of claims 58-63; and
a second computing device configured to access the advertising content element.

1/4

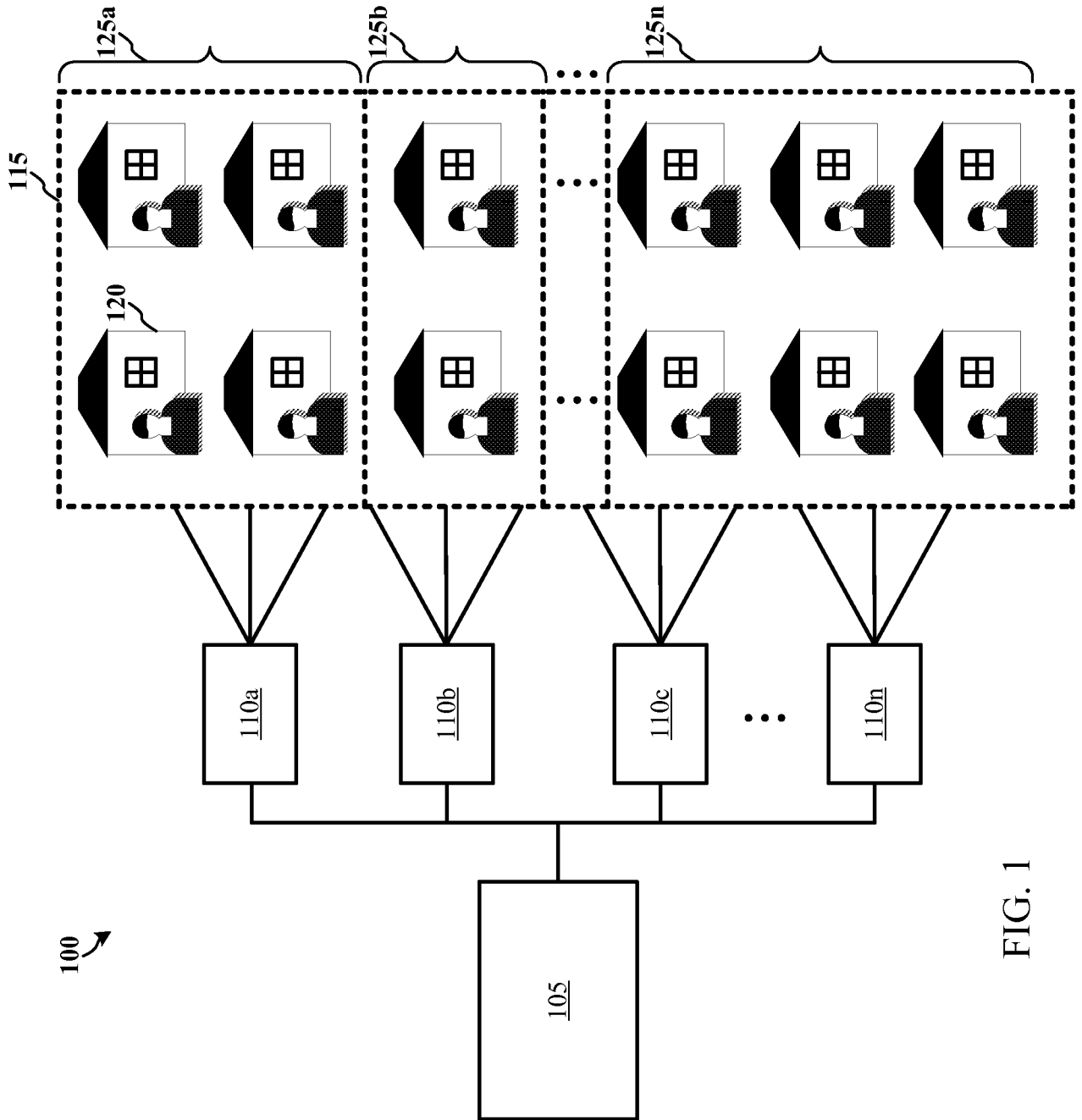

FIG. 1

2/4

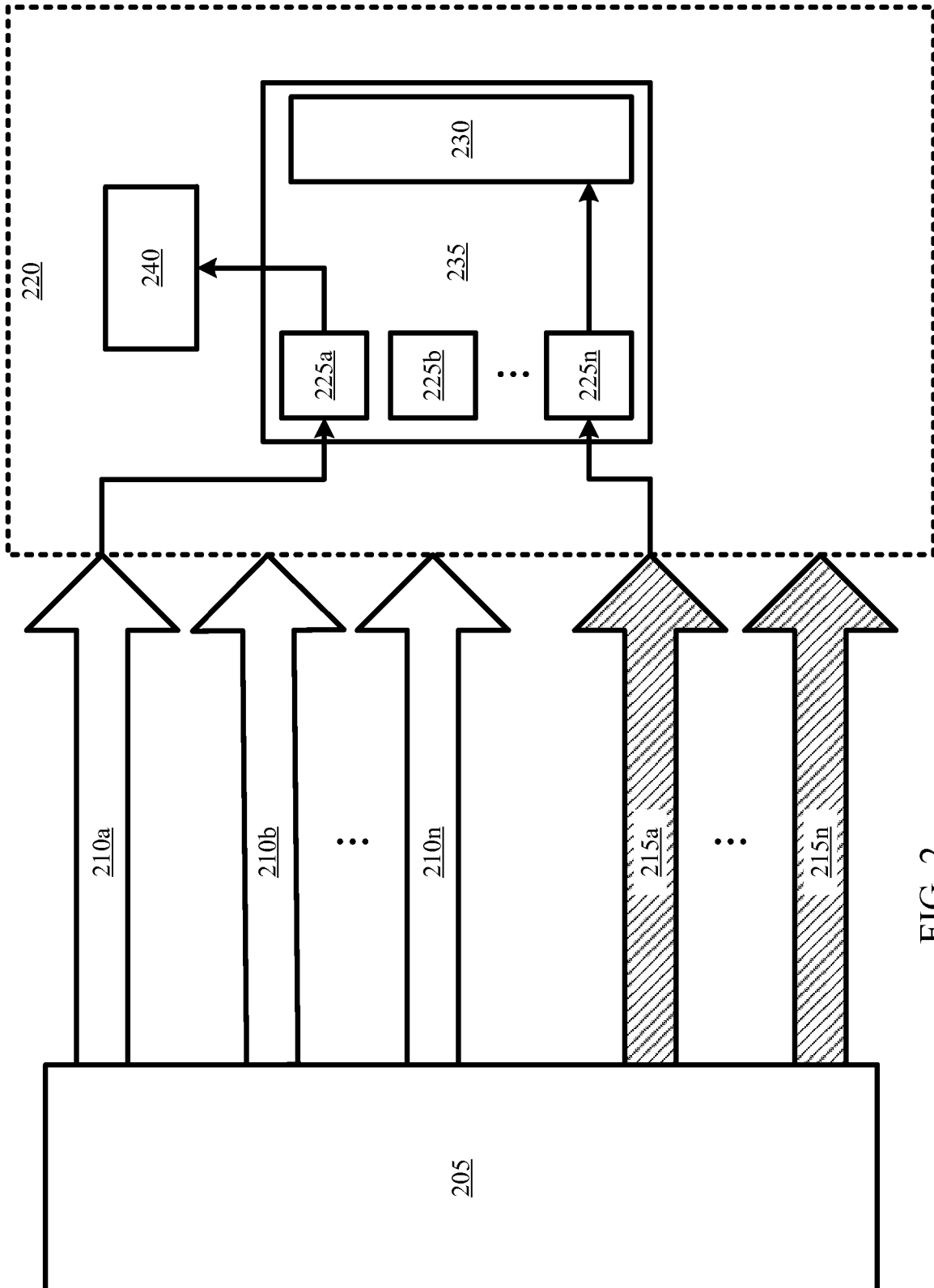

FIG. 2

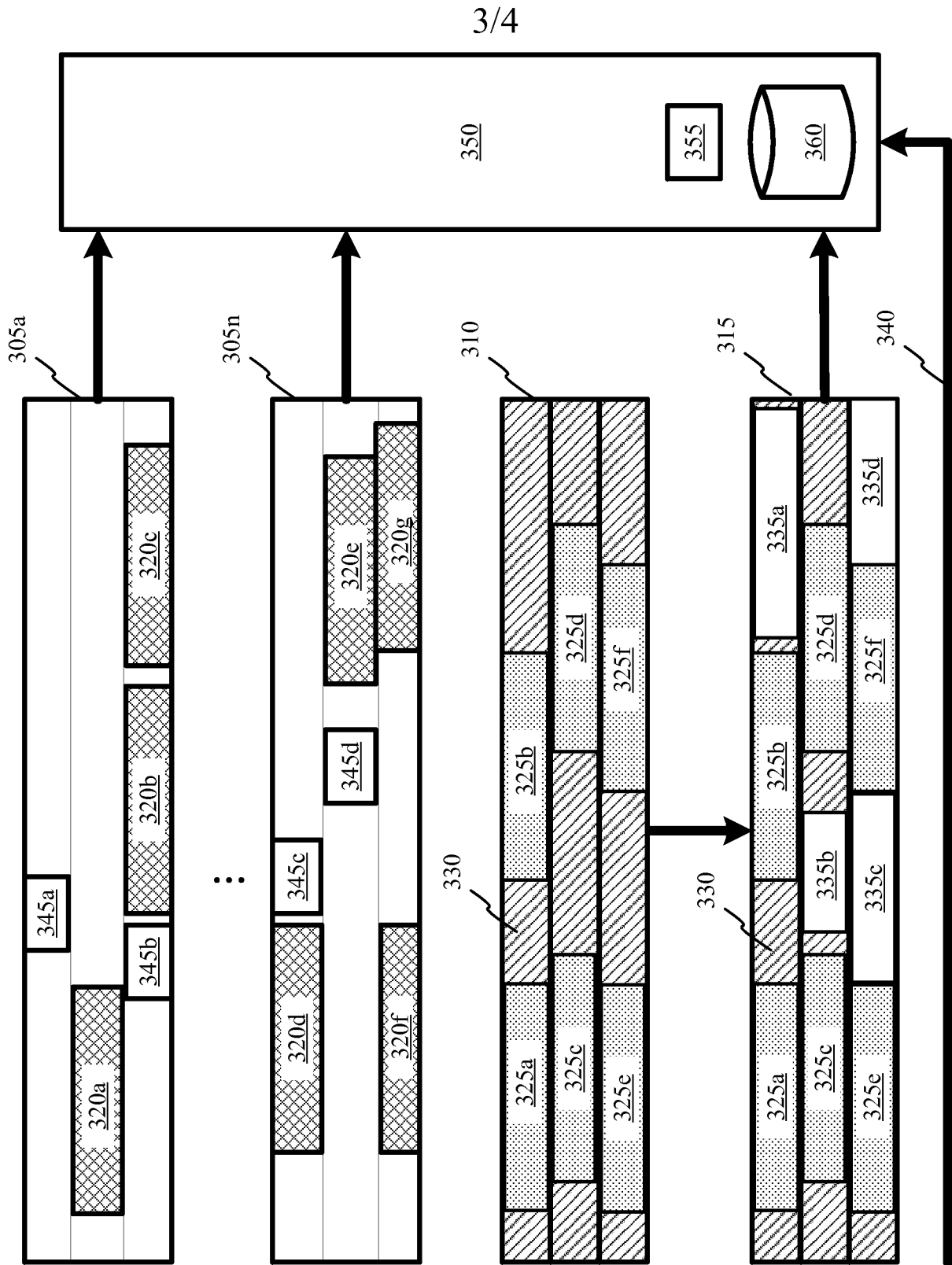

FIG. 3

4/4

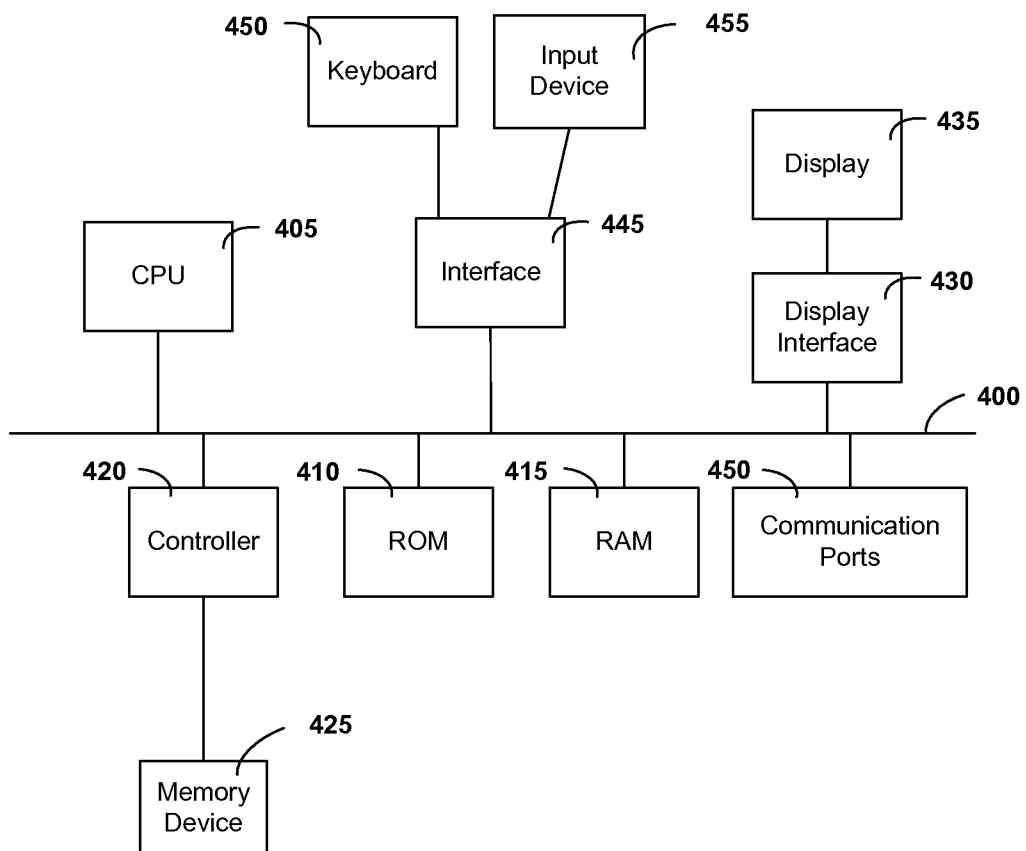

FIG. 4

