

Aug. 10, 1965

H. SYBERTZ

3,199,799

CUTTER FOR WOOD-SHAVING MACHINE

Filed Nov. 20, 1962

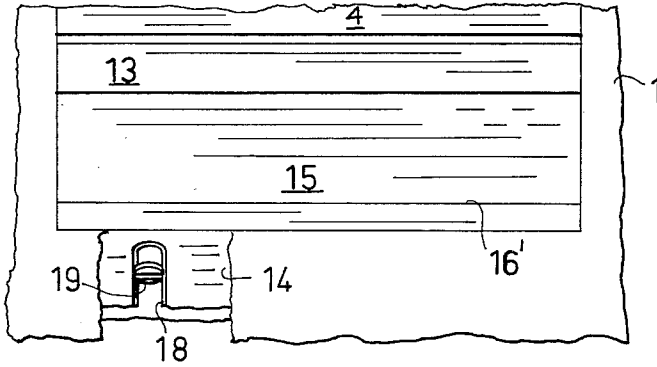

Fig. 3

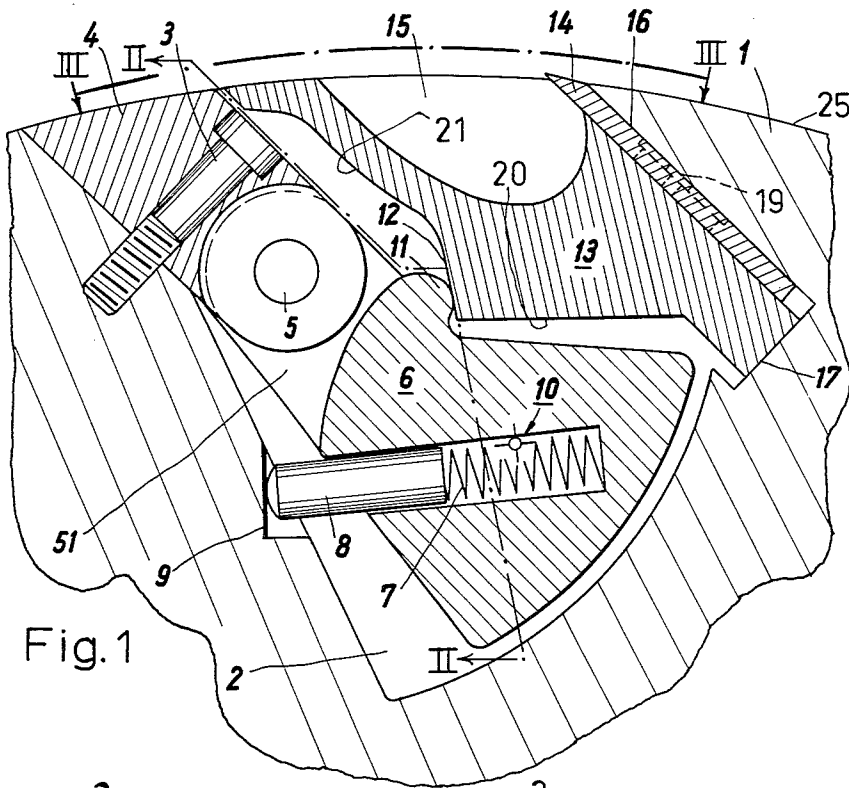

Fig. 1

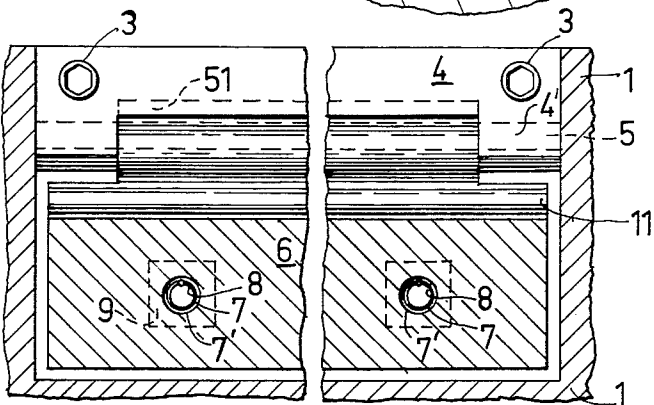

Fig. 2

Inventor:
Hans Sybertz
BY *Karl G. Koss*
AGENT

1

2

3,199,799

CUTTER FOR WOOD-SHAVING MACHINE

Hans Sybertz, Bad Kreuznach, Germany, assignor to
Hombak Maschinenfabrik K.G., Bad Kreuznach,
Germany, a corporation of Germany

Filed Nov. 20, 1962, Ser. No. 238,909

Claims priority, application Germany, Nov. 20, 1961,

H 44,175

6 Claims. (Cl. 241—294)

My present invention relates to improved cutters for wood-shaving machines and, more particularly, to the cutter bodies of wood-comminuting apparatus.

In general, the cutter body of such apparatus is provided with one or more blade members which are held in place by a tightening screw or wedge means to insure a rigid positioning of the blade member even upon rotation of the body. It has also been proposed to provide such arrangements with a clamping member operable upon rotation of the body under the action of centrifugal force to insure that the blade member will not become unseated. In the latter arrangements wedges, bolts and the like are nevertheless employed to force the blade member unyieldably into its seat to prevent shifting of the blade upon cessation of the rotary motion. In each case removal of the clamping member with its consequent inconvenience is required when the blades are to be changed or adjusted. In addition, these prior-art mechanisms are costly and of complicated construction.

It is an object of the present invention to provide a cutter of the character described wherein the blades are secured with a simplified but nevertheless efficient means. A more specific object of the invention is to provide screw means for the blade of a cutter bar wherein the disadvantages of earlier arrangements employing clamping bolts, wedges, etc., are entirely obviated.

These objects are obtained, in accordance with the invention, by providing a cutter with at least one outwardly open peripheral recess and blade means mounted in said recess with a securing means yieldable bearing on the blade means in a stationary condition of the body but including a detent whose center of gravity is offset from a pivotal axis parallel to the axis of rotation of the body whereby the detent surface bears upon the blade means under the action of centrifugal force upon rotation of the body. Advantageously, the recess is provided with an undercut portion against which the blade means is held by the detent whose center of gravity is disposed between this undercut portion and a common plane of the body and pivotal axes. Thus, the blade means may be formed with a pair of outwardly converging surfaces, one of which is engaged by the detent to wedge the blade means within the recess while the other abuts a wall thereof.

According to a more specific feature of the invention, the detent member is provided with a clamping surface eccentric with respect to the pivotal axis and bearing upon a wedge surface of the blade means. The blade means is, preferably, provided with a canning surface engageable with the detent for urging it away from the undercut portion of the recess whereby the blade means can be inserted into the recess into seating relationship therein.

Yet another feature of the invention resides in the provision of a detent member bears resiliently upon the blade means under the action of one or more springs for preventing the blade from slipping out of the recess in the stationary condition of the body. While the blade means referred to may simply be a blade shaped to conform to the configuration of the recess, I prefer to employ a blade-support member upon which a blade is removably mounted. The blade-support member may, therefore, be provided with the requisite chip-clearing channel and a

seating surface adapted to engage positively the walls of the recess. Since there is no tendency for the blade to shift within the recess, the entry of dust, chips and other particles between the seating surface is obviated.

To obtain a maximum centrifugal effect and to permit maximum utilization of the spring force, I prefer to orient the detent member so that its clamping surface is disposed intermediate its center of gravity and pivotal axis, thereby gaining a lever-action mechanical advantage equal substantially to the quotient of the distance from this axis to the center of gravity and the clamping surface. Similarly, the spring means may effectively bear upon the detent member at a location more remote from the pivotal axis than the clamping surface. The latter may be formed on an axially extending protruberance of the detent member so that it engages the blade means substantially over its entire length. Thus, the detent member may be provided with one or more arms extending radially from its pivotal axis and bearing, at their free extremities, a mass centrifugally displaceable upon rotation of the body.

The above and other objects, features and advantages of the instant invention will become more readily apparent from the following description, reference being made to the accompanying drawing in which:

FIG. 1 is a radial cross-sectional view through a rotary cutter embodying the invention;

FIG. 2 is a cross-sectional view taken along line II—II of FIG. 1 and drawn to a reduced scale; and

FIG. 3 is a view taken along the line III—III of FIG. 1, with parts broken away, and drawn to the same scale as FIG. 2.

In FIG. 1 I show a portion of the cutter of a wood-comminuting machine which is provided with a plurality of angularly spaced blades extending outwardly from the periphery of the cutter body 1. Although the present drawing shows but a single one of these blades, it should be understood that identical means can be employed to secure the remaining blades in place. In addition, it should be noted that such securing means are also effective for wood-shaping apparatus and other devices employing a rotary cutter body. The body 1 is formed with a recess 2 having an undercut portion 16. A plurality of bolts 3 (FIGS. 1 and 2) secure a journal block 4 within this recess. This block carries a shaft 5 about which the arm 51 of a weighted detent member 6 is journaled. Arm 51 is, of course, representative of any means articulating the detent member upon shaft 5 and may be replaced by a plurality of axially spaced radial arms as will be readily apparent. The center of gravity 10 of the detent member 6 is offset from its pivotal axis (i.e., that of shaft 5) and is disposed intermediate an axial plane of body 1 passing through shaft 5 and the undercut surface 16 of the recess so that rotation of the body effects a displacement of the detent member counterclockwise into engagement with blade means 13, 14.

The blade means comprises a support 13 upon which the blade 14 is adjustably secured by screws 19 which pass through slots 18 in the blade into engagement with the body. Thus, the distance above the periphery 25 of the body 1 beyond which the blade 14 projects may be changed by shifting the blade along the screws. The support 13 has its lower end seated against a surface 17 of the recess and is provided with a channel 15 for clearing chips of wood removed by the blade. The detent member 6 is formed with an axially extending protruberance 11 which is eccentric with respect to the pivotal axis of the detent and thus bears upon a wedge surface 12 of the support to clamp the latter against the undercut wall 16 of the recess upon rotation of the body 1. Surface 12 and wall 16 converge outwardly to effect a wedge-

type action preventing displacement of the blade means 13, 14. In addition, support 13 is provided with a camming surface 20 which acts upon the protuberance 11 upon generally radial insertion of the support 13 into the recess 2 to rotate the detent 6 clockwise to clear the support. Springs 7 are received within bars 7' in the detent member and bear upon pins 8 shiftable within these bars in a direction generally transverse to the aforementioned axial plane. Pins 8 bear upon wall surfaces 9 of the recesses 2 whereby the detent member 6 is yieldably biased against the blade support 13. This spring means is, like the center of gravity 10 of the detent, spaced from the shaft 5 by a distance greater than that between the latter and the protuberance 11 so that both the spring and centrifugal actions are applied to the blade means with mechanical advantage.

The centrifugal force acting upon the detent 6 with rotation of the body 1 and the resilient bias of spring 7 suffice to seat the blade and support against the surfaces 16 and 17 at all times without the risk that particles may become interposed between the seating surfaces. It should be noted that the use of a tool for unseating member 13 can be avoided since the shape of protuberance 11 permits removal of the support member in a direction parallel to surface 16 by merely withdrawing it against the force of spring 7. A depression 21 is provided within blade support 13 to facilitate its manipulation.

The invention as described and illustrated admits of many modifications and variations which are deemed to be embraced within the spirit and scope of the invention as defined in the appended claims.

I claim:

1. A cutter for a wood-comminuting machine, comprising a generally cylindrical body rotatable about an axis and formed with at least one outwardly open peripheral recess; blade means seated in said recess, said blade means comprising a blade-support member and a blade mounted upon said support member; and securing means in said recess yieldably bearing upon said support member for clamping said blade means releasably within said recess in a stationary condition of said body and centrifugally actuatable to wedge said blade means in said recess upon rotation of said body, said securing means including a journal block secured within said recess, an axially extending shaft in said block, a weighted detent member swingably mounted on said shaft and having a center of gravity intermediate an axial plane of said body through said shaft and said support member, said members being formed with co-operating surfaces for wedging said support member within said recess upon said rotation of said body, and spring means within said recess for urging said detent member against said support member, thereby releasably retaining the latter within said recess.

2. A cutter for a wood-shaving machine, comprising a body rotatable about an axis and formed with an outwardly open peripheral recess, said recess having an undercut portion; blade means removably seated in said portion of said recess, said blade means including a blade-carrying member and a blade mounted upon said blade-carrying member; support means including a journal

block secured to said body within said recess and forming a pivot parallel to said axis; and detent means swingably mounted on said journal block in said recess for angular displacement about said pivot, said detent means having a center of gravity offset from said pivot and a laterally projecting, axially extending protuberance cammingly engageable with said blade means for holding said blade-carrying member against the undercut portion of said recess and upon rotation of said body to centrifugally urge said detent means against said blade-carrying member; and resilient means bearing upon said detent means and yieldably biasing said detent means in the direction of said blade means.

3. A cutter for a wood-shaving machine, comprising a body rotatable about an axis and formed with an outwardly open peripheral recess, said recess including an undercut portion having an inclined abutment wall; blade means removably seated in said portion of said recess, said blade means including a blade-carrying member having a pair of contact surfaces converging in an outward direction from said recess, said blade means including a blade mounted upon one of the contact surfaces of said blade-carrying member and seated against said inclined abutment surface; support means including a journal block secured to said body within said recess and forming a pivot parallel to said axis; detent means swingably mounted on said journal block in said recess for angular displacement about said pivot, said detent means having a center of gravity offset from said pivot and a laterally projecting, axially extending protuberance cammingly engageable with the other contact surface of said blade-carrying member for holding said blade-carrying member against the undercut portion of said recess and, upon rotation of said body, to centrifugally urge said detent means against said blade-carrying member; and resilient means bearing upon said detent means and yieldably biasing said detent means in the direction of said blade means.

4. A cutter as defined in claim 3 wherein said resilient means comprises at least one spring bearing upon said detent member.

5. A cutter as defined in claim 3 wherein said spring is effective at a location on said detent member spaced from said pivotal axis by a distance greater than the distance between said pivotal axis and said surface.

6. A cutter as defined in claim 3 wherein said center of gravity is located at a distance from said pivot greater than the distance between said pivot and said protuberance.

References Cited by the Examiner

UNITED STATES PATENTS

86,850	2/69	Maulick	143—152
3,014,511	12/61	Kirsten	144—230
3,017,912	1/62	Sybertz et al.	144—173 X

FOREIGN PATENTS

915,265	7/54	Germany.
---------	------	----------

J. SPENCER OVERHOLSER, *Primary Examiner.*