

Oct. 8, 1957

J. M. BIDDISON
APPARATUS FOR AND METHOD OF APPLYING
INSULATING MATERIAL TO COILS

2,809,141

Filed Nov. 15, 1954

2 Sheets-Sheet 1

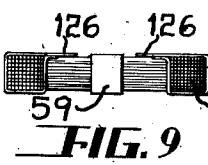
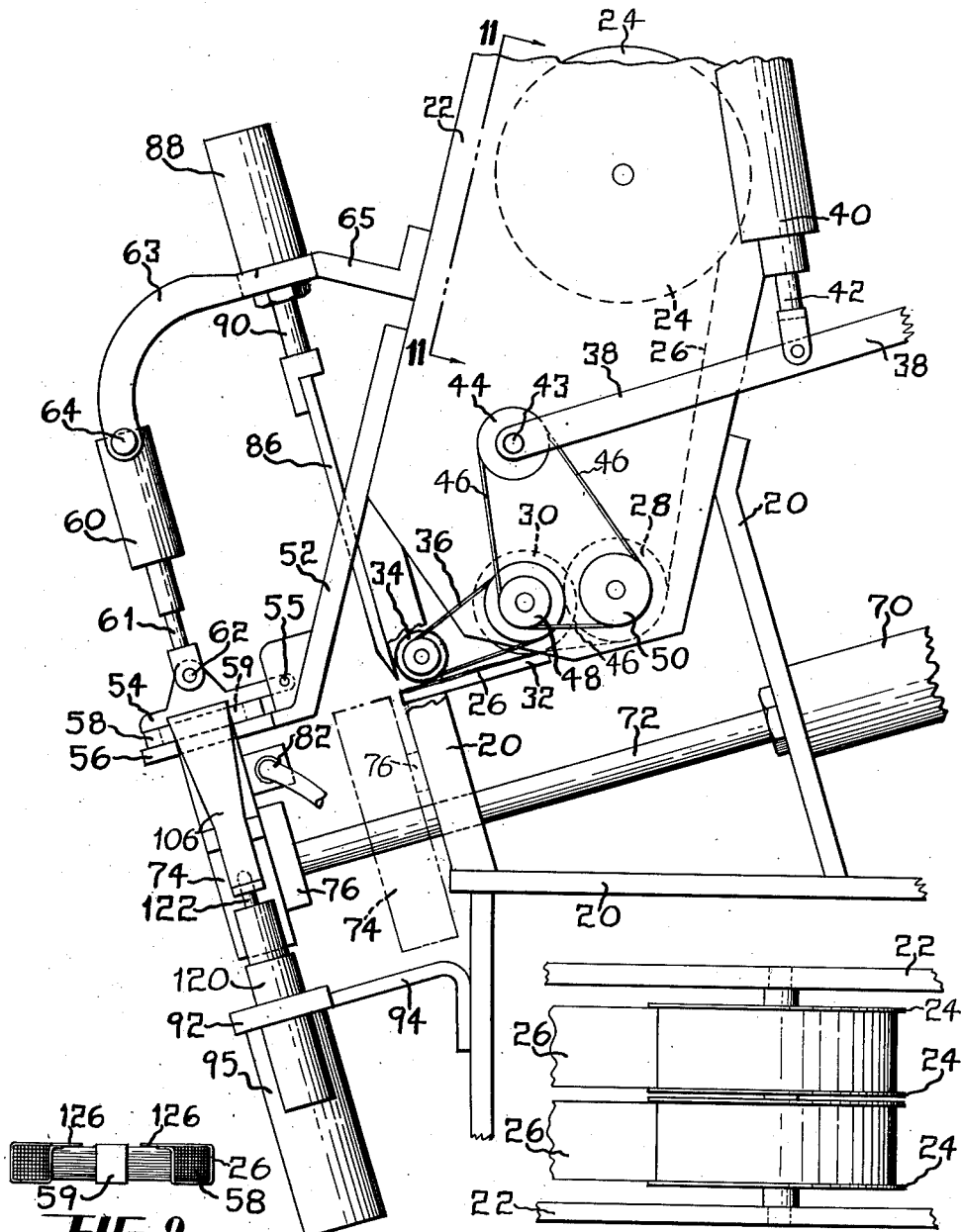

FIG. 9

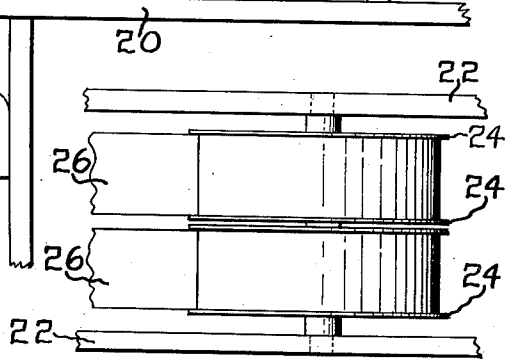

FIG. 11

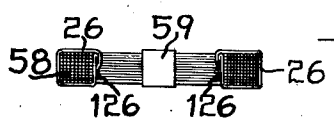

FIG. 10

FIG. 1

INVENTOR.
JOHN M. BIDDISON
BY *DeWing & Jones*
HIS ATTORNEYS

Oct. 8, 1957

J. M. BIDDISON
APPARATUS FOR AND METHOD OF APPLYING
INSULATING MATERIAL TO COILS

2,809,141

Filed Nov. 15, 1954

2 Sheets-Sheet 2

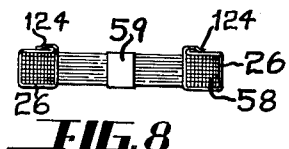
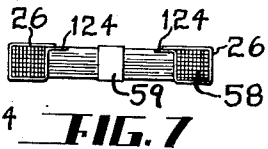
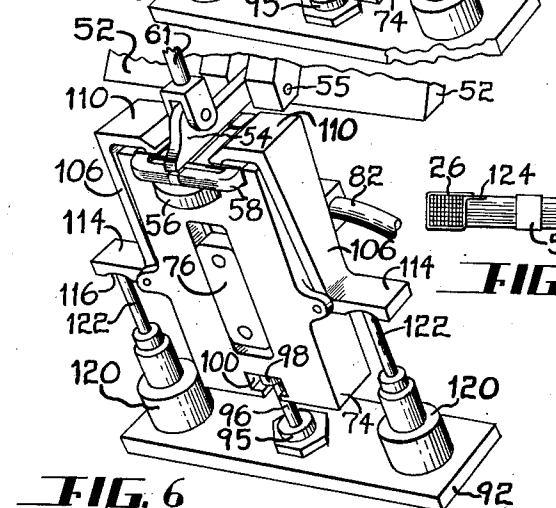
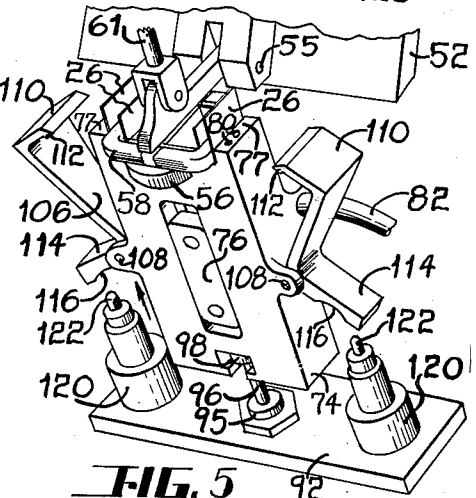
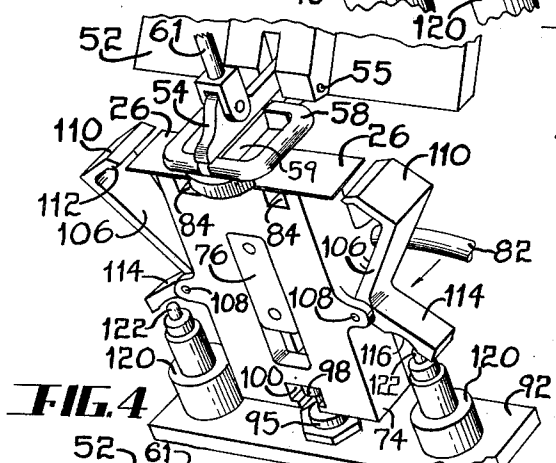
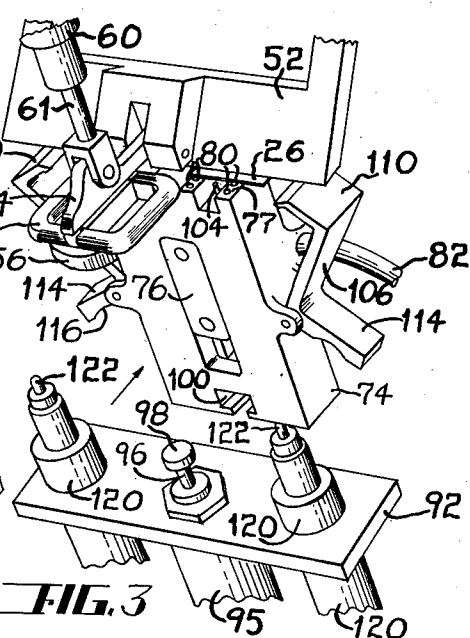
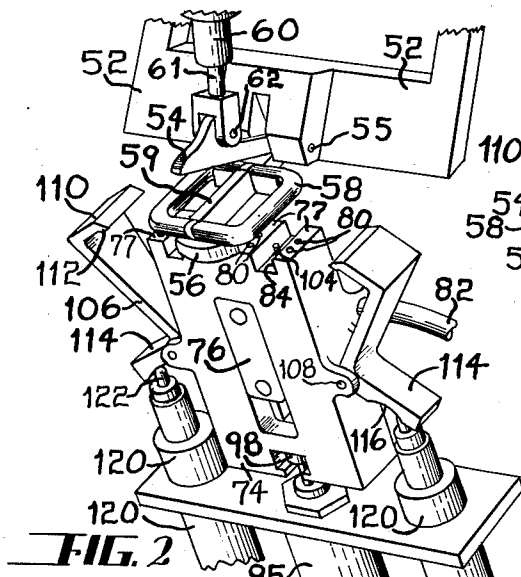

INVENTOR.
JOHN M. BIDDISON
BY *Dybing & Jacob*
HIS ATTORNEYS

1

2,809,141

APPARATUS FOR AND METHOD OF APPLYING INSULATING MATERIAL TO COILS

John M. Biddison, Dayton, Ohio, assignor to Harry W. Moore, Dayton, Ohio

Application November 15, 1954, Serial No. 468,896

14 Claims. (Cl. 154—2.25)

This invention relates to an apparatus for and method of applying insulation material to coils. This invention particularly relates to the application of insulation material to electric coils. However, the invention is not so limited in that it may be used in the application of any type of insulating material to coils. The invention may also be used in the applying of any type of strip material to coils of various kinds and forms.

In the manufacture of electric coils for electrical apparatus a problem has long existed with regard to the wrapping of insulation upon a coil. Ordinarily, it has been necessary to apply the insulation material to the coils manually. This manual procedure has been very slow and thus production of such insulated coils has been very tedious and expensive.

Hence, an object of this invention is to provide an apparatus for applying insulation material to electric coils.

Another object of this invention is to provide a method for applying insulation material to coils.

Another object of this invention is to provide an insulating machine which is capable of rapid operation and high-quality work.

Other objects and advantages reside in the construction of parts, the combination thereof and the mode of operation, as will become more apparent from the following description.

In the drawings,

Figure 1 is a fragmentary side elevational view of the apparatus of this invention for applying insulating material to coils.

Figure 2 is a fragmentary perspective view showing the carriage member and forward structure of this invention with a coil retained by the support structure.

Figure 3 is a front perspective view similar to that of Figure 2 showing the carriage member in a retracted position for receiving sections of insulation material.

Figure 4 is a perspective view similar to that of Figures 2 and 3, showing the carriage member in its forward position with insulation material supported thereby.

Figure 5 is a front perspective view similar to that of Figures 2, 3 and 4, showing the carriage member in a raised position in which the carriage member engages the coil held by the clamping member.

Figure 6 is a front perspective view similar to that of Figures 2, 3, 4 and 5, with the carriage member in its raised position with the arm members of the carriage member in an actuated position.

Figure 7 is a sectional view, slightly enlarged, of a typical coil wrapped with insulation material by a machine of this invention.

Figure 8 is a sectional view, similar to that of Figure 7, of a typical coil showing the insulation material as it is adhesively retained in a folded-back position after having been wrapped about the coil by the machine of this invention.

Figure 9 is a sectional view similar to that of Figures 7 and 8, showing a preferred modification in the posi-

2

tioning of the sections of insulation material upon a coil, so that the ends of the sections may be folded on the inner surfaces of the coil sides.

Figure 10 is a sectional view similar to Figure 9, showing the folded position of the ends of the sections of insulation material against the inner surfaces of the coil sides.

Figure 11 is a sectional view taken substantially on line 11—11 of Figure 1.

Referring to the drawings in detail, the apparatus of this invention comprises a support frame structure 20. Mounted upon the support structure 20 is a paper roll housing 22. Within the paper roll housing 22 is rotatively mounted a pair of rolls 24. Upon each roll 24 is wound a strip of insulation material 26. The strips of insulation material 26 extend in parallel relation from the rolls 24 to paper feed wheels 28 and 30, which are rotatably carried by the housing 22. The pair of adjacent continuous strips of insulation material 26 continue from the rolls 24, engage the paper feed wheel 28, and then engage the paper feed wheel 30, as clearly shown in Figure 1. The paper feed wheels 28 and 30 are each composed of a plurality of spaced-apart axially aligned discs. The discs of one wheel are partially interposed with the discs of the other wheel, as shown in Figure 1.

From the paper feed wheel 30 the strips of insulation material 26 move over a short table member 32. The two strips of insulation material 26 are moved in parallel relation over the table 32 by means of a feed roller 34 which may be driven from the feed wheel 30 by means of a belt member 36.

A ratchet arm 38 actuated by a fluid motor 40, having an operating rod 42 attached to the ratchet arm 38, provides means for feeding equal lengths or sections of strip material 26 upon each actuation of the arm 38 by the fluid motor 40. The arm 38 is pivotally attached to a pin 43 and drives a ratchet mechanism 44 attached to the pin 43.

The ratchet mechanism 44 also serves as a drive wheel which is operatively connected by means of a chain or belt 46 to a pulley wheel 48 of the feed wheel 30 and a pulley wheel 50 of the feed wheel 28. Preferably the pulley wheel 48 of the feed wheel 30 is slightly smaller than the pulley wheel 50 of the feed wheel 28, so that the feed wheel 30 rotates slightly faster than the feed wheel 28 upon each actuation of the arm 38.

A support bracket 52 attached to the housing 22 carries a movable coil clamping member 54 which is pivotally attached to the bracket 52 by means of a pin 55. The bracket 52 also rigidly supports a coil clamping base 56. The pivotally mounted movable coil clamp 54 and the stationary coil clamp base 56 cooperate in retaining a coil 58. The clamping base 56 may be provided with a vertically attached cross block 59. The cross block member 59 extends between opposite sides of the coil 58 and aids in retaining the coil 58 in proper alignment between the clamping members 54 and 56 by abutting the opposite sides of the coil 58 when the coil 58 is positioned upon the stationary clamping member 56.

A fluid motor 60 has an operating rod 61 thereof pivotally attached by means of a pin 62 to the clamp member 54 to pivotally move the clamp member 54 for opening or closing the clamping means. The fluid motor 60 is pivotally attached to an arcuate bracket 63 by means of a pin 64. The arcuate bracket 63 is attached to the housing 22 by means of a brace member 65. It is to be understood, within the purview of this invention, that other suitable means, different from the fluid motor 60, for operating the clamping member 54 may also be employed.

A fluid motor 70 carried by the support structure 20

3

and provided with an operating rod 72 is adapted to reciprocally move a carriage member 74 from a position adjacent the table 32 to a position adjacent the clamping members 54 and 56. At the end of the operating rod 72 is a carrier block 76 normal thereto to which is slidably attached the carriage member 74.

The coil 58, to be wrapped with insulation material 26, is placed upon the stationary clamping member 56, as clearly shown in Figure 2. The fluid motor 60 is then actuated, pivotally moving the movable clamping member 54 into engagement with the coil 58, as clearly shown in Figure 3. While the clamping member 54 is being operatively moved into clamping position with the coil 58, the fluid motor 70, by means of the operating rod 72, moves the carriage member 74 toward the table 32.

At the moment the carriage member 74 reaches its position adjacent the table member 32, as shown by dash lines in Figure 1, the fluid motor 40 is actuated, pivotally operating the arm 38 through a predetermined length of stroke. Thus, the ratchet member 44 is rotated, driving the feed wheels 28 and 30 through a predetermined rotational movement. The feed wheels 28 and 30 thus carry a desired length of the strip material 26 from each of the rolls 24 simultaneously, and the feed roller 34 issues these two lengths from the table member 32 to an upper surface 77 of the carriage member 74. In Figure 3 is shown the strip material 26 moving upon the upper surface 77 of the carriage member 74.

The upper surface 77 of the carriage member 74 is provided with a plurality of apertures 80 which lead inwardly within the carriage member 74 and connect to an air line 82. The air line 82 is adapted for use as a vacuum or suction line. When the carriage member 74 moves toward the table 32 to receive the sections of strip material, suction of air through the apertures 80 through the air line 82 is started. Hence, when the two sections of strip material 26 are received upon the upper surface 77 of the carriage member 74, these sections of strip material 26 cover the apertures 80 and are firmly retained thereon by air pressure or suction pressure. The upper surface 77 of the carriage member 74 is also provided with a pair of transverse slots or grooves 84. The sections of insulation material 26 extend over the grooves 84.

When the predetermined length of strip material has been issued from each roll 24 by the feed roller 34 to the upper surface 77 of the carriage member 74, these two sections of strip material 26 are severed from the remainder of their respective strips by means of a knife member 86. The knife member 86 is sufficiently wide to contact both strips of insulation material 26. The knife member 86 is reciprocally operated adjacent the table member 32 by means of a fluid motor 88 provided with an operating rod 90. The fluid motor 88 is rigidly mounted at the juncture of the arcuate bracket 63 and the brace member 65.

After the two sections of strip material 26 are severed simultaneously from the remainder of the strips by a stroke of the knife member 86, the carriage member 74, carrying the sections of strip material, is immediately moved to its position adjacent the stationary clamping member 56 by means of the operating rod 72 of the fluid motor 70. The carriage member 74, when so positioned, is also adjacent an actuator assembly 92, which is retained by a bracket 94 which is attached to the support structure 20. The carriage member 74 is thus positioned intermediate the clamping member 56 and the actuator assembly 92, as best shown in Figure 4.

Included in the actuator assembly 92 is a fluid motor 95 provided with an operating rod 96, having attached at the end thereof a head member 98. The lower portion of the carriage member 74 is provided with a T-shaped slot 100, as best shown in Figure 3, which is adapted to receive the head 98 which is attached to the operating rod 96 of the fluid motor 95. When the carriage mem-

4

ber 74, as it is moved by the fluid motor 70, reaches its position adjacent the actuator assembly 92, the fluid motor 95 is actuated. The fluid motor 95 thus moves its operating rod 96 upwardly causing the head member 98 to engage the carriage member 74. Due to the fact that the carriage member 74 is slidably attached to the carrier block 76, the carriage member 74 is thus moved upwardly by the head member 98 so that the upper surface 77 of the carriage member 74 engages the coil 58, as best shown in Figure 5.

Due to the fact that opposite sides of the coil 58 extend from the stationary clamping member 56, the opposite sides of the coil 58 may readily be received within the slots 84 of the upper surface 77 of the carriage member 74. Due to the fact that the sections of strip material 26 extend over the grooves or slots 84, the movement of the carriage member 74 into engagement with the coil 58 causes the sections of insulation material 26 to be partially wrapped around the sides of the coil 58, as best shown in Figure 5. At the moment the carriage member 74, in its upward movement, reaches the coil 58, the air pressure or suction pressure through the air line 82 is automatically stopped so that the section of insulation material 26 may easily wrap itself about the sides of the coil 58, as clearly shown in Figure 5.

Within each groove 84 is a pin member 104 which is resiliently retained in a position extending into the groove 84. These pins 104 aid in firmly retaining and aligning the sections of insulating material 26 against the sides of the coil 58 within the grooves 84 as the carriage member 74 engages the coil 58 and the sides of the coil become disposed within the grooves 84.

Attached to the carriage member 74 on opposite sides thereof are a pair of arm members 106 hingedly secured by means of pintles 108. At the upward end of each of the arms 106 is a normally extending finger member 110 which is provided with a lip 112 at the end thereof. Attached to each arm 106, and extending normal thereto, at the pivotal point thereof, is an abutment flange 114 having an arcuate recess 116 in the lower surface thereof.

At the moment the carriage member 74 reaches the upward limit of its movement causing the sections of insulation material 26 to partially wrap themselves about the sides of the coil 58, as shown in Figure 5, a pair of fluid motors 120 are simultaneously operated, as shown in Figure 6. These fluid motors 120 are included in the actuator assembly 92 and are mounted on either side of the fluid motor 95. Each of the fluid motors 120 has an operating rod 122, the end of which engages the arcuate recess 116 of its respective abutment flange 114, causing the arm members 106 to pivotally rotate. This results in the movement of the fingers 110 inwardly causing each section of strip material 26 to be completely wrapped about a side of the coil 58, as best shown in Figure 6. The fluid motors 120 are then deactuated, which results in release of the arms 106 for pivotal movement outwardly. The fluid motor 95 is then deactuated, permitting return movement of the carriage member 74 to its normal position. Following this, the fluid motor 60 is operated, moving the pivotally movable clamping member 54 upwardly so that the coil 58 having the insulation material 26 wrapped about its sides may be removed. The coil 58 with the strip material 26 then appears as shown in Figure 7.

Preferably the strip material 26, which is used as insulation material herein, is provided upon one surface thereof with a coating of adhesive means. The surface of the strip material which is provided with the adhesive means is the surface which engages the coil 58. Due to the fact that the insulation material 26 is provided on one surface thereof with adhesive means, the section of insulation material 26 is firmly fixed to the coil 58. As best shown in Figure 7, after the coil 58 is removed from the clamping members 54 and 56, an extending portion or lip 124 of each section of strip material 26 ex-

ists, the upper surface of which has adhesive material thereon. This lip 124 may be folded back and over, as shown in Figure 8, and adhesively retains itself to the other portion of the strip material 26.

It is to be understood that the sections of strip material 26 may also be so applied to the sides of the coil 58 that a lip 126 exists, as shown in Figure 9, which may be folded in the manner shown in Figure 10. The sections of insulation material 26 may be applied by the machine of this invention so that a lip of insulation exists at other portions of the coil, or the insulation material may be applied so that there is no lip of insulation existing for folding. Such folded material may add to the insulative protection of the coil. Ordinarily, the final operation of folding insulation material 26 may be manually accomplished by the operator of the machine of this invention as the coil 58 is removed from the stationary clamping member 56.

It is to be understood that the method and apparatus of this invention may be employed in the application of only one strip of material to a coil, or the application of any plurality of strips.

It is also to be understood that the method and apparatus of this invention may be employed in the taping of a plurality of coils simultaneously.

Although the preferred embodiment of the device has been described, it will be understood that within the purview of this invention various changes may be made in the form, details, proportion and arrangement of parts, the combination thereof and mode of operation, which generally stated consist in a device capable of carrying out the objects set forth, as disclosed and defined in the appended claims.

Having thus described my invention, I claim:

1. An apparatus for applying insulation material from a supply thereof to coils comprising support structure, coil clamping means attached to the support structure, the insulation material supply being carried by the support structure in spaced relation from the coil clamping means, insulation material carrying means movable from a position adjacent the insulation material supply to a position adjacent the coil clamping means, the insulation material carrying means being provided with air pressure means for securing the insulation material to the insulation material carrying means, means for moving the insulation material carrying means into engagement with a coil retained by the coil clamping means, and arm means attached to the insulation material carrying means engageable with insulation material retained by the coil clamping means, said arm means being adapted to move portions of said insulation material against the coil retained by the coil clamping means.

2. In a machine for wrapping flexible material from a supply thereof about an article of manufacture, the combination comprising support structure, the supply of flexible material being carried by the support structure, a clamping member attached to the support structure for retaining an article of manufacture, the clamping member retaining the article of manufacture so that opposite surfaces thereof are exposed, means for transferring flexible material from the supply thereof to the clamping member, said means being provided with fluid suction means for securing flexible material thereto, said means for transferring flexible material being movable into engagement with one surface of the article of manufacture which is retained by the clamping member, said means for transferring flexible material being provided with a depression portion for receiving the article of manufacture, the flexible material being retained adjacent said depression portion by the fluid suction means during transfer of the flexible material, portions of the flexible material forced against said article of manufacture by said engagement, and means for forcing further wrapping of said flexible material about said article of manufacture.

3. An apparatus for applying insulation material from a roll thereof to coils comprising support structure, the roll of strip material being supported by the support structure, strip material feed means carried by the support structure for feeding a strip of insulation material from the roll of strip material, a coil holding member supported by the support structure in spaced relation from the strip material feed means, an actuator assembly retained by the support structure in spaced alignment with respect to the coil holding member, a carriage member having means for reciprocal movement thereof from a position adjacent the strip material feed means to a position intermediate the actuator assembly and the coil holding member, the strip material feed means being adapted to extend a section of insulation material from the roll of strip material to the carriage member when the carriage member is adjacent the strip material feed means, means for severing said section of the strip of insulation material from the remainder of the strip, the carriage member being provided with air pressure means for securing the section of insulation material to the carriage member while the carriage member moves to its position intermediate the coil holding member and the actuator assembly, the actuator assembly including a reciprocally movable rod for moving the carriage member toward the coil holding member, the carriage member being moved to engagement with a coil retained by the coil holding member, the carriage member being provided with a pair of slots for receiving opposite coil sides of the coil retained by the coil holding member, engagement of the carriage member with the coil causing the section of insulation material to be partially wrapped about a side of the coil, a pair of arm members attached to the carriage member, the actuator assembly also having a pair of piston actuated rods, there being one rod for each of the arm members, the rods being adapted to engage the arm members moving the arm members to a position engaging the coil, the arm members carrying portions of the section of insulation material against the coil.

4. An apparatus for wrapping flat flexible material from a supply thereof about an article of manufacture, the combination comprising support structure, the supply of flexible material being carried by the support structure, clamping means for retaining an article of manufacture, the clamping means being supported by the support structure in spaced relation from the supply of flexible material, carrier means for transferring flexible material from the supply thereof to the clamping means, the carrier means having a surface for receiving the flexible material from the supply thereof, means for providing suction of air at said surface of the carrier means for retaining flexible material upon said surface, and means adjacent the clamping means for forcing flexible material carried by the carrier means to engage an article of manufacture retained by the clamping means.

5. In a method of applying insulation material to an electric coil comprising the steps of retaining a coil in a fixed position, moving a section of insulation material to the coil by carrying means provided with air pressure means to secure the insulation material to the carrying means, placing the carrying means against the coil so that the insulation material engages the coil, wrapping the insulation material about the coil, removing the carrying means and folding upon the coil any insulation material protruding from the coil.

6. In an apparatus for applying flexible insulation material from a roll thereof to an electric coil, the combination comprising support structure, the roll of insulation material being carried by the support structure, dispensing means for issuing a predetermined amount of flexible insulation material from the roll thereof, a retainer member attached to the support structure for retaining an electric coil, a carriage member movable between the dispensing means and the retainer member,

the carriage member being provided with a receiver surface for receiving flexible insulation material issued from the dispensing means, the receiver surface having a pair of coil receiving slots therein, reciprocal means adjacent the retainer member and engageable with the carriage member for moving the receiver surface of the carriage member into engagement with the coil held by the retainer member, said movement of the carriage member causing positioning of portions of the coil within the slots of the receiver surface, and arm means attached to the carriage member for engagement with flexible insulation material carried by the carriage member.

7. In an apparatus for applying flexible insulation material from a supply thereof to an electric coil, the combination comprising support structure, the supply of insulation material being carried by the support structure, dispenser means for issuing a predetermined amount of insulation material from the supply thereof, a retainer member attached to the support structure for retaining a coil, a carrier member movable intermediate the dispenser means and the retainer member, the carrier member being provided with a receiver surface for receiving flexible insulation material issued from the dispenser means, the receiver surface having a pair of coil receiving slots therein, the receiver surface also being provided with a plurality of apertures therein and having conduit means leading to the apertures for providing air flow through the apertures for securing flexible insulation material to the receiver surface, reciprocal means adjacent the retainer member and engageable with the carrier member for moving the carrier member so that the receiver surface thereof engages the coil held by the retainer member, said movement of the carrier member causing positioning of portions of the insulation material and portions of the coil within the slots of the receiver surface, and arm means adjacent the retainer member for engagement with flexible insulation material to provide folding movement thereof.

8. An apparatus for wrapping flexible material from a supply thereof about an article of manufacture, the combination comprising support structure, the supply of flexible material being carried by the support structure, means for issuing a section of flexible material from the supply thereof, clamping means for retaining an article of manufacture, the clamping means being fixedly attached to the support structure in spaced relation from the supply of flexible material, receiver means for receiving a section of flexible material issued from the supply thereof, means for movement of the receiver means for engagement between the receiver means and an article of manufacture held by the clamping means, means for providing air flow through a portion of the receiver means and movable therewith for securing a section of flexible material to said receiver means, and means carried by the receiver means for urging a section of flexible material to wrap about an article of manufacture retained by the clamping means.

9. In a machine for applying insulating material from a supply thereof to electric coils, the combination comprising a coil retaining member, the supply of insulating material being in spaced relation from the coil retaining member, a reciprocally operable carriage member for moving insulating material from the supply thereof to the coil retaining member, means for severing a portion of insulating material held by the carriage member from the supply of insulating material and a conduit member attached to the carriage member for providing fluid pressure upon a portion of insulating material carried by the carriage member to secure the insulating material to the carriage member during movement of the carriage member.

10. In a machine for wrapping flexible insulation material upon an electric coil comprising a coil retaining

member, an insulation retaining member, means for providing relative movement between the retaining members, the insulation retaining member being provided with fluid pressure means to secure flexible insulation material thereto, one of said retaining members being provided with an arm member engageable with the flexible insulation material, the arm member providing wrapping motion to the flexible insulation material.

11. In an apparatus for applying flexible material to coils comprising a coil retainer member, flexible material feed means in spaced relation from the coil retainer member, a flexible material retainer member, means for causing relative movement between said retainer members, an arm member pivotally attached to one of said retainer members and engageable with flexible material held by the flexible material retainer member, the arm member being operable to cause folding movement of flexible material upon a coil held by the coil retainer member, and a reciprocally movable actuator member engageable with the arm member for operation thereof.

12. In an apparatus for applying flexible material to coils, the combination comprising flexible material feed means, a coil retainer member disposed in spaced relation from the flexible material feed means, the feed means being adapted to dispense a section of flexible material, a flexible material carrier member movable from a position adjacent the flexible material feed means to a position adjacent the coil retainer member to transfer a section of insulation material, an actuator member engageable with the flexible material carrier member for movement of the section of flexible material carrier member into engagement with a coil held by the coil retainer member, the flexible material carrier member being provided with a surface for carrying flexible material, said surface having an aperture therein, the flexible material carrier member being provided with a fluid conduit member leading to the aperture.

13. In an apparatus for applying flexible material to coils, the combination comprising a flexible material feed means, the feed means being adapted to dispense a plurality of strips of flexible material, a coil retainer member adapted to retain a plurality of coils disposed in spaced relation from the flexible material feed means, a flexible material carrier member adapted to transfer a plurality of strips of flexible material from a position adjacent the flexible material feed means to a position adjacent the coil retainer member, an actuator member engageable with the flexible material carrier member for movement of the flexible material carrier member into engagement with a coil held by the coil retainer member, the flexible material carrier member being provided with a surface for carrying flexible material, said surface having a plurality of apertures therein, the flexible material carrier member being provided with a fluid conduit member leading to the apertures.

14. In a method of applying insulation material to an electric coil comprising the steps of retaining a coil in a fixed position, moving a section of insulation material to the coil by carrying means provided with air pressure means to secure the insulation material to the carrying means, placing the carrying means against the coil so that the insulation material engages the coil, and wrapping the insulation material about the coil.

References Cited in the file of this patent

UNITED STATES PATENTS

1,980,022	Whitehouse	Nov. 6, 1934
2,318,056	Christman	May 4, 1943
2,334,030	Ranney et al.	Nov. 9, 1943
2,484,600	Weiser et al.	Oct. 11, 1949
2,557,831	Lucenti	June 19, 1951
2,705,978	Caldwell	Apr. 12, 1955