

(19) World Intellectual Property Organization
International Bureau



(43) International Publication Date
16 May 2002 (16.05.2002)

PCT

(10) International Publication Number
WO 02/39260 A2

- (51) International Patent Classification⁷: **G06F 9/00** (US). **WANG, Ho**; 2317 Waterway Bend, Austin, TX 78728 (US).
- (21) International Application Number: PCT/US01/45518
- (22) International Filing Date:
2 November 2001 (02.11.2001)
- (25) Filing Language: English
- (26) Publication Language: English
- (30) Priority Data:
60/246,443 7 November 2000 (07.11.2000) US
09/797,197 1 March 2001 (01.03.2001) US
- (71) Applicant: **SURGIENT NETWORKS, INC.** [US/US];
8303 Mopac, Suite C300, Austin, TX 78746 (US).
- (72) Inventors: **RICHTER, Roger, K.**; 15248 Faubion Trail,
Leander, TX 78641 (US). **HERNANDEZ, Gustavo, G.**;
3500 Greystone Drive, Apartment #108, Austin, TX 78731
- (74) Agent: **ENDERS, William, W.**; O'Keefe, Egan & Peterman, LLP, 1101 Capital of Texas Highway South, Building C, Suite 200, Austin, TX 78746 (US).
- (81) Designated States (*national*): AE, AG, AL, AM, AT, AU, AZ, BA, BB, BG, BR, BY, BZ, CA, CH, CN, CO, CR, CU, CZ, DE, DK, DM, DZ, EC, EE, ES, FI, GB, GD, GE, GH, GM, HR, HU, ID, IL, IN, IS, JP, KE, KG, KP, KR, KZ, LC, LK, LR, LS, LT, LU, LV, MA, MD, MG, MK, MN, MW, MX, MZ, NO, NZ, PH, PL, PT, RO, RU, SD, SE, SG, SI, SK, SL, TJ, TM, TR, TT, TZ, UA, UG, UZ, VN, YU, ZA, ZW.
- (84) Designated States (*regional*): ARIPO patent (GH, GM, KE, LS, MW, MZ, SD, SL, SZ, TZ, UG, ZW), Eurasian patent (AM, AZ, BY, KG, KZ, MD, RU, TJ, TM), European patent (AT, BE, CH, CY, DE, DK, ES, FI, FR, GB, GR, IE, IT, LU, MC, NL, PT, SE, TR), OAPI patent (BF, BJ, CF, CG, CI, CM, GA, GN, GQ, GW, ML, MR, NE, SN, TD, TG).

[Continued on next page]

(54) Title: METHODS AND SYSTEMS FOR THE ORDER SERIALIZATION OF INFORMATION IN A NETWORK PROCESSING ENVIRONMENT

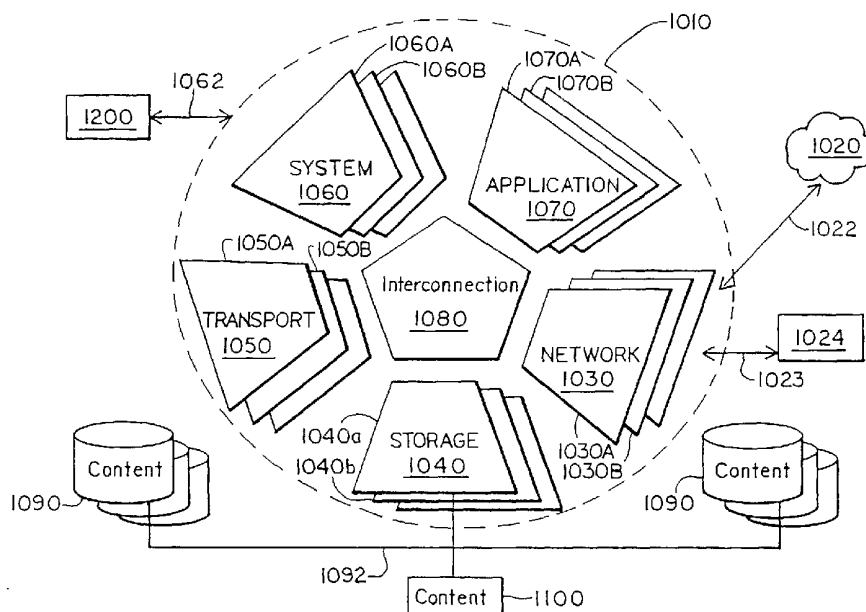

(57) Abstract: A multi-processor network processing environment is provided in which parallel processing may occur. In one embodiment, a network processor having multiple processor cores may be utilized. Parallel processing at the front end of the network processor is encouraged while still maintaining ordered serialization between the input and the output of the network processor. The disclosed order serialization techniques obtain the benefits of parallel processing at the front end of the system while minimizing blocking times at the output.

WO 02/39260 A2



Published:

— without international search report and to be republished upon receipt of that report

For two-letter codes and other abbreviations, refer to the "Guidance Notes on Codes and Abbreviations" appearing at the beginning of each regular issue of the PCT Gazette.

**METHODS AND SYSTEMS FOR THE ORDER SERIALIZATION OF
INFORMATION IN A NETWORK PROCESSING ENVIRONMENT**

5

BACKGROUND OF THE INVENTION

The present invention relates generally to network connected computing systems, and more particularly to order serialization in a multi-processor network processing environment.

10 A wide variety of computing systems may be connected to computer networks. These systems may include network endpoint systems and network intermediate node systems. Servers and clients are typical examples of network endpoint systems. Network switches and routers are typical examples of network intermediate node systems. Many other types of network endpoint systems and network intermediate node systems also exist.

15 As the desire for increased network bandwidth, speed and general performance is always present, many different techniques have been utilized to achieve such goals. A common technique to address network bottlenecks is to simply provide more network connected resources. One scenario is to deploy a set of autonomous computing systems that all run in parallel 'behind' a network device that distributes the workload or data to the set of
20 systems utilizing load-balancing schemes. For example, in an internet data center environment the set of computer systems may be coupled to a load-balancing network switch that distributes network traffic/data to the set of systems operating as servers. Thus, in this server environment the server compute bottleneck is often dealt with by merely adding more servers that are operating in parallel and are coupled to a load-balancing network switch.
25 This has been called a "rack and stack" or "server farm" solution. This solution addresses network performance problems that have developed due to a lack of computing power available in server systems with respect to multi-gigabit media rates available in current networks. In such solutions parallel processing is utilized to increase the overall system performance.

30 Presently, network and computer technologies use parallel and distributed processing techniques to increase overall throughput and enhance performance in a wide variety of other applications. Some technologies presently deployed for parallel/distributed processing range from hardware-centric solutions to software-centric solutions. Examples of some current implementations are: Symmetric Multi-Processing (SMP) in the personal computer and work

station-based server arena, fault tolerant processor arrays in high-end, non-stop servers, and distributed computing software systems such as distributed computing environment (DCE). These solutions process data in a distributed and parallel manner to minimize latency, maximize throughput, and optimize efficient use of computing resources.

5

Parallel processing may also occur within an individual package (i.e. chip, chipset or I/O board) utilized in a network connected device. Thus, in a single package, multiple "processing cores" may be provided with each core operating in parallel to address the necessary processing rates. One such device utilizing multiple processor cores is the network processor. In some examples, network processors may have four, eight, sixteen or more processor cores operating in parallel. Typically network processors are designed for the specialized function of performing tasks at a network intermediate node. Network processors are often utilized in network switches and routers to forward network traffic at the intermediate node. Network processors typically include multiple processor cores that operate in parallel, with some special purpose cores, to achieve the forwarding functionality. The use of the parallel processing cores allows several processing units within the network processor to process data simultaneously. The use and configuration of network processors are described in more detail below.

In a typical network processor application, workloads that are presented to a network processor are assigned to a processing core in a sequential or round robin manner. The workloads typically exit the processor cores in the same sequence as the workloads are presented to the network processor, or in other words, the arrival order and the departure order of workloads are generally the same. Because the sequence of the workloads is maintained, the workloads do not become de-sequenced. The arrival and departure orders are maintained in typically network processor applications because of the nature of the application. In the typical network switching environment the tasks being performed on each data packet arriving at the network processor are the same. For example, the network processor may merely look at the header of each packet and then forward the packet. Thus the amount of time required for processing each data packet (a workload) is relatively constant.

The multiple processor cores of the network processor may each individually "grab" a data packet and process the packet with the time for each packet being constant and

independent of which processor core performs the processing. Because the time for each packet is constant, the output results for the stream of packets presented to the processor cores will be provided in an order sequence that matches the order sequence that the packets were input to the network processor. In other words, if the input sequence of the packet stream is Packet A, Packet B, Packet C, and Packet D, the output sequence of the network processor will be Results for Packet A, Results for Packet B, Results for Packet C and Results for Packet D. These sequences will be maintained even if each packet is processed by a different processing core.

It will be understood that the maintenance of the input/output order sequence in the typical network processor application generally inherently occurs because the time to perform each workload is the same. Thus as task are assigned from one processor core to the next, the order sequence is maintained not because of any programming or circuitry techniques employed with the network processor, but rather, as a result of the tasks the network processor typically performs. Furthermore, although a network processor generally maintains the order sequence of workloads it is not a requirement for most network processor applications that strict order sequence be maintained. Most network protocols anticipate that data packets may become de-sequenced as transmission occurs across a network. Thus at the network endpoint (such as a server) it is anticipated that the packets may be re-sequenced upon arrival at the network endpoint. However, within most endpoint devices strict order sequence of workloads is typically required. De-sequencing in network endpoint devices significantly reduces the efficiency and performance of the network endpoint device.

The workloads performed at a network endpoint are very different from the workloads performed at a switching, or routing, device. Generally the workloads performed at the network endpoint may vary greatly from data packet to data packet. For example, some data packet related tasks may include checksum computation and verification, packet replication, network header rebuilding, etc. and may require lengthier processing for larger data packets or shorter processing for smaller data packets. As such, two data packets having varying sizes and sent by the same node sequentially may be require different processing times. The parallel operation of the multiple cores of the network processor has a high probability of de-sequencing these types of workloads. The inability to maintain proper data packet sequencing for varying tasks is one reason that network processors have been considered inappropriate for use at network endpoints.

The network processor approach to processing provides a cost effective solution, and greater throughput for certain applications, but does not account for enforcing arrival-departure order dependencies that may be needed in other applications, for example endpoint
5 node processing. It would be desirable to combine the benefits of a network processor with the ability to maintain order sequences. Furthermore it would be desirable to achieve this combination with standard commercially available network processors. Additionally it would be highly desirable to maintain order sequence dependencies in a highly efficient manner so as not to reduce the throughput benefits of a network processor.

10

SUMMARY OF THE INVENTION

A multi-processor network processing environment is provided in which parallel processing may occur. In one embodiment, a network processor having multiple processor cores may be utilized. Parallel processing at the front end of the network processor is
15 encouraged while still maintaining ordered serialization between the input and the output of the network processor. The disclosed order serialization techniques obtain the benefits of parallel processing at the front end of the system while minimizing blocking times at the output.

20

As each new data packet arrives at the network processor, the network processor is programmed to assign the packet to a particular processor core in some known sequence of processor cores. The network processor is also programmed to provide the output of each processor core as the network processor output in the same sequence of processor cores. In this manner, the input/output order serialization is maintained.

25

Thus, multiple data packets of information may be communicated to a network processing system and one or more processing cores may process the data packets in a parallel processing manner that maintains order serialization even though the packets may require varying processing times. This technique allows a network processor to be suitable
30 for use in a network endpoint system. The sequence that is utilized for providing workloads to the processor cores and determine the output order of the workload results from the processor cores may be managed through the use of a processing output token.

The sequence at which packets are assigned to processor cores and which the outputs
35 are obtained may be a static sequence or a dynamic sequence. An exemplary static sequence

may be a round robin sequence. A static sequence may also be a user defined sequence list. A dynamic sequence may also be utilized. Each of the various sequences may be utilized in conjunction with a processing token. The processor token may be utilized to manage the output order of the workload results from the various processing cores.

5

DESCRIPTION OF THE FIGURES

FIG. 1A is a representation of components of a content delivery system according to one embodiment of the disclosed content delivery system.

10 FIG. 1B is a representation of data flow between modules of a content delivery system of FIGURE 1A according to one embodiment of the disclosed content delivery system.

FIG. 1C is a simplified schematic diagram showing one possible network content
15 delivery system hardware configuration.

FIG. 1D is a simplified schematic diagram showing a network content delivery engine configuration possible with the network content delivery system hardware configuration of FIG. 1C.

20

FIG. 1E is a simplified schematic diagram showing an alternate network content delivery engine configuration possible with the network content delivery system hardware configuration of FIG. 1C.

25 FIG. 1F is a simplified schematic diagram showing another alternate network content delivery engine configuration possible with the network content delivery system hardware configuration of FIG. 1C.

FIGS. 1G-1J illustrate exemplary clusters of network content delivery systems.

30

FIG. 2 is a simplified schematic diagram showing another possible network content delivery system configuration.

FIG. 2A is a simplified schematic diagram showing a network endpoint computing system.

FIG. 2B is a simplified schematic diagram showing a network endpoint computing
5 system.

FIG. 3 is a functional block diagram of an exemplary network processor.

FIG. 4 is a functional block diagram of an exemplary interface between a switch
10 fabric and a processor.

FIG. 5 is a block diagram of a network processor having multiple processor cores.

FIG. 6 is a network connected system utilizing the order serialization techniques
15 disclosed herein.

FIG. 7 is one method for processing information utilizing the order serialization techniques disclosed herein.

FIG. 8 illustrates one embodiment of a processing output token according to the
20 present invention.

FIG. 9 is one method for processing information utilizing the order serialization techniques disclosed herein.

25

FIG. 10 is one method for processing information utilizing the order serialization techniques disclosed herein.

FIGS. 11A and 11B illustrate exemplary network processors utilizing multiple input
30 and/or output queues.

FIG. 12 illustrates a distributed computer environment in which the present invention may be utilized.

DETAILED DESCRIPTION

Disclosed herein are systems and methods for operating network connected computing systems. The network connected computing systems disclosed provide a more efficient use of computing system resources and provide improved performance as compared to traditional network connected computing systems. Network connected computing systems may include network endpoint systems. The systems and methods disclosed herein may be particularly beneficial for use in network endpoint systems. Network endpoint systems may include a wide variety of computing devices, including but not limited to, classic general purpose servers, specialized servers, network appliances, storage area networks or other storage medium, content delivery systems, corporate data centers, application service providers, home or laptop computers, clients, any other device that operates as an endpoint network connection, etc.

Other network connected systems may be considered a network intermediate node system. Such systems are generally connected to some node of a network that may operate in some other fashion than an endpoint. Typical examples include network switches or network routers. Network intermediate node systems may also include any other devices coupled to intermediate nodes of a network.

Further, some devices may be considered both a network intermediate node system and a network endpoint system. Such hybrid systems may perform both endpoint functionality and intermediate node functionality in the same device. For example, a network switch that also performs some endpoint functionality may be considered a hybrid system. As used herein such hybrid devices are considered to be a network endpoint system and are also considered to be a network intermediate node system.

For ease of understanding, the systems and methods disclosed herein are described with regards to an illustrative network connected computing system. In the illustrative example the system is a network endpoint system optimized for a content delivery application. Thus a content delivery system is provided as an illustrative example that demonstrates the structures, methods, advantages and benefits of the network computing system and methods disclosed herein. Content delivery systems (such as systems for serving streaming content, HTTP content, cached content, etc.) generally have intensive input/output demands.

It will be recognized that the hardware and methods discussed below may be incorporated into other hardware or applied to other applications. For example with respect to hardware, the disclosed system and methods may be utilized in network switches. Such switches may be considered to be intelligent or smart switches with expanded functionality beyond a traditional switch. Referring to the content delivery application described in more detail herein, a network switch may be configured to also deliver at least some content in addition to traditional switching functionality. Thus, though the system may be considered primarily a network switch (or some other network intermediate node device), the system may incorporate the hardware and methods disclosed herein. Likewise a network switch performing applications other than content delivery may utilize the systems and methods disclosed herein. The nomenclature used for devices utilizing the concepts of the present invention may vary. The network switch or router that includes the content delivery system disclosed herein may be called a network content switch or a network content router or the like. Independent of the nomenclature assigned to a device, it will be recognized that the network device may incorporate some or all of the concepts disclosed herein.

The disclosed hardware and methods also may be utilized in storage area networks, network attached storage, channel attached storage systems, disk arrays, tape storage systems, direct storage devices or other storage systems. In this case, a storage system having the traditional storage system functionality may also include additional functionality utilizing the hardware and methods shown herein. Thus, although the system may primarily be considered a storage system, the system may still include the hardware and methods disclosed herein. The disclosed hardware and methods of the present invention also may be utilized in traditional personal computers, portable computers, servers, workstations, mainframe computer systems, or other computer systems. In this case, a computer system having the traditional computer system functionality associated with the particular type of computer system may also include additional functionality utilizing the hardware and methods shown herein. Thus, although the system may primarily be considered to be a particular type of computer system, the system may still include the hardware and methods disclosed herein.

As mentioned above, the benefits of the present invention are not limited to any specific tasks or applications. The content delivery applications described herein are thus illustrative only. Other tasks and applications that may incorporate the principles of the

present invention include, but are not limited to, database management systems, application service providers, corporate data centers, modeling and simulation systems, graphics rendering systems, other complex computational analysis systems, etc. Although the principles of the present invention may be described with respect to a specific application, it will be recognized that many other tasks or applications performed with the hardware and methods.

Disclosed herein are systems and methods for delivery of content to computer-based networks that employ functional multi-processing using a "staged pipeline" content delivery environment to optimize bandwidth utilization and accelerate content delivery while allowing greater determination in the data traffic management. The disclosed systems may employ individual modular processing engines that are optimized for different layers of a software stack. Each individual processing engine may be provided with one or more discrete subsystem modules configured to run on their own optimized platform and/or to function in parallel with one or more other subsystem modules across a high speed distributive interconnect, such as a switch fabric, that allows peer-to-peer communication between individual subsystem modules. The use of discrete subsystem modules that are distributively interconnected in this manner advantageously allows individual resources (*e.g.*, processing resources, memory resources) to be deployed by sharing or reassignment in order to maximize acceleration of content delivery by the content delivery system. The use of a scalable packet-based interconnect, such as a switch fabric, advantageously allows the installation of additional subsystem modules without significant degradation of system performance. Furthermore, policy enhancement/enforcement may be optimized by placing intelligence in each individual modular processing engine.

25

The network systems disclosed herein may operate as network endpoint systems. Examples of network endpoints include, but are not limited to, servers, content delivery systems, storage systems, application service providers, database management systems, corporate data center servers, etc. A client system is also a network endpoint, and its resources may typically range from those of a general purpose computer to the simpler resources of a network appliance. The various processing units of the network endpoint system may be programmed to achieve the desired type of endpoint.

30

Some embodiments of the network endpoint systems disclosed herein are network endpoint content delivery systems. The network endpoint content delivery systems may be utilized in replacement of or in conjunction with traditional network servers. A "server" can be any device that delivers content, services, or both. For example, a content delivery server
5 receives requests for content from remote browser clients via the network, accesses a file system to retrieve the requested content, and delivers the content to the client. As another example, an applications server may be programmed to execute applications software on behalf of a remote client, thereby creating data for use by the client. Various server appliances are being developed and often perform specialized tasks.

10

As will be described more fully below, the network endpoint system disclosed herein may include the use of network processors. Though network processors conventionally are designed and utilized at intermediate network nodes, the network endpoint system disclosed herein adapts this type of processor for endpoint use.

15

The network endpoint system disclosed may be construed as a switch based computing system. The system may further be characterized as an asymmetric multi-processor system configured in a staged pipeline manner.

20 EXEMPLARY SYSTEM OVERVIEW

FIG. 1A is a representation of one embodiment of a content delivery system 1010, for example as may be employed as a network endpoint system in connection with a network 1020. Network 1020 may be any type of computer network suitable for linking computing systems. Content delivery system 1010 may be coupled to one or more networks including,
25 but not limited to, the public internet, a private intranet network (e.g., linking users and hosts such as employees of a corporation or institution), a wide area network (WAN), a local area network (LAN), a wireless network, any other client based network or any other network environment of connected computer systems or online users. Thus, the data provided from the network 1020 may be in any networking protocol. In one embodiment, network 1020
30 may be the public internet that serves to provide access to content delivery system 1010 by multiple online users that utilize internet web browsers on personal computers operating through an internet service provider. In this case the data is assumed to follow one or more of various Internet Protocols, such as TCP/IP, UDP, HTTP, RTSP, SSL, FTP, etc. However, the same concepts apply to networks using other existing or future protocols, such as IPX,

SNMP, NetBios, Ipv6, etc. The concepts may also apply to file protocols such as network file system (NFS) or common internet file system (CIFS) file sharing protocol.

Examples of content that may be delivered by content delivery system 1010 include, 5 but are not limited to, static content (*e.g.*, web pages, MP3 files, HTTP object files, audio stream files, video stream files, *etc.*), dynamic content, *etc.* In this regard, static content may be defined as content available to content delivery system 1010 via attached storage devices and as content that does not generally require any processing before delivery. Dynamic content, on the other hand, may be defined as content that either requires processing before 10 delivery, or resides remotely from content delivery system 1010. As illustrated in FIG. 1A, content sources may include, but are not limited to, one or more storage devices 1090 (magnetic disks, optical disks, tapes, storage area networks (SAN's), *etc.*), other content sources 1100, third party remote content feeds, broadcast sources (live direct audio or video broadcast feeds, *etc.*), delivery of cached content, combinations thereof, *etc.* Broadcast or 15 remote content may be advantageously received through second network connection 1023 and delivered to network 1020 via an accelerated flowpath through content delivery system 1010. As discussed below, second network connection 1023 may be connected to a second network 1024 (as shown). Alternatively, both network connections 1022 and 1023 may be connected to network 1020.

20

As shown in FIG. 1A, one embodiment of content delivery system 1010 includes multiple system engines 1030, 1040, 1050, 1060, and 1070 communicatively coupled via distributive interconnection 1080. In the exemplary embodiment provided, these system engines operate as content delivery engines. As used herein, "content delivery engine" 25 generally includes any hardware, software or hardware/software combination capable of performing one or more dedicated tasks or sub-tasks associated with the delivery or transmittal of content from one or more content sources to one or more networks. In the embodiment illustrated in FIG. 1A content delivery processing engines (or "processing blades") include network interface processing engine 1030, storage processing engine 1040, 30 network transport / protocol processing engine 1050 (referred to hereafter as a transport processing engine), system management processing engine 1060, and application processing engine 1070. Thus configured, content delivery system 1010 is capable of providing multiple dedicated and independent processing engines that are optimized for networking, storage and

application protocols, each of which is substantially self-contained and therefore capable of functioning without consuming resources of the remaining processing engines.

It will be understood with benefit of this disclosure that the particular number and
5 identity of content delivery engines illustrated in FIG. 1A are illustrative only, and that for
any given content delivery system 1010 the number and/or identity of content delivery
engines may be varied to fit particular needs of a given application or installation. Thus, the
number of engines employed in a given content delivery system may be greater or fewer in
number than illustrated in FIG. 1A, and/or the selected engines may include other types of
10 content delivery engines and/or may not include all of the engine types illustrated in FIG. 1A.
In one embodiment, the content delivery system 1010 may be implemented within a single
chassis, such as for example, a 2U chassis.

Content delivery engines 1030, 1040, 1050, 1060 and 1070 are present to
15 independently perform selected sub-tasks associated with content delivery from content
sources 1090 and/or 1100, it being understood however that in other embodiments any one or
more of such subtasks may be combined and performed by a single engine, or subdivided to
be performed by more than one engine. In one embodiment, each of engines 1030, 1040,
1050, 1060 and 1070 may employ one or more independent processor modules (*e.g.*, CPU
20 modules) having independent processor and memory subsystems and suitable for
performance of a given function/s, allowing independent operation without interference from
other engines or modules. Advantageously, this allows custom selection of particular
processor-types based on the particular sub-task each is to perform, and in consideration of
factors such as speed or efficiency in performance of a given subtask, cost of individual
25 processor, *etc.* The processors utilized may be any processor suitable for adapting to
endpoint processing. Any "PC on a board" type device may be used, such as the x86 and
Pentium processors from Intel Corporation, the SPARC processor from Sun Microsystems,
Inc., the PowerPC processor from Motorola, Inc. or any other microcontroller or
microprocessor. In addition, network processors (discussed in more detail below) may also
30 be utilized. The modular multi-task configuration of content delivery system 1010 allows the
number and/or type of content delivery engines and processors to be selected or varied to fit
the needs of a particular application.

The configuration of the content delivery system described above provides scalability without having to scale all the resources of a system. Thus, unlike the traditional rack and stack systems, such as server systems in which an entire server may be added just to expand one segment of system resources, the content delivery system allows the particular resources
5 needed to be the only expanded resources. For example, storage resources may be greatly expanded without having to expand all of the traditional server resources.

DISTRIBUTIVE INTERCONNECT

Still referring to FIG. 1A, distributive interconnection 1080 may be any multi-node
10 I/O interconnection hardware or hardware/software system suitable for distributing functionality by selectively interconnecting two or more content delivery engines of a content delivery system including, but not limited to, high speed interchange systems such as a switch fabric or bus architecture. Examples of switch fabric architectures include cross-bar switch fabrics, Ethernet switch fabrics, ATM switch fabrics, etc. Examples of bus architectures
15 include PCI, PCI-X, S-Bus, Microchannel, VME, etc. Generally, for purposes of this description, a "bus" is any system bus that carries data in a manner that is visible to all nodes on the bus. Generally, some sort of bus arbitration scheme is implemented and data may be carried in parallel, as n-bit words. As distinguished from a bus, a switch fabric establishes independent paths from node to node and data is specifically addressed to a particular node
20 on the switch fabric. Other nodes do not see the data nor are they blocked from creating their own paths. The result is a simultaneous guaranteed bit rate in each direction for each of the switch fabric's ports.

The use of a distributed interconnect 1080 to connect the various processing engines
25 in lieu of the network connections used with the switches of conventional multi-server endpoints is beneficial for several reasons. As compared to network connections, the distributed interconnect 1080 is less error prone, allows more deterministic content delivery, and provides higher bandwidth connections to the various processing engines. The distributed interconnect 1080 also has greatly improved data integrity and throughput rates as compared
30 to network connections.

Use of the distributed interconnect 1080 allows latency between content delivery engines to be short, finite and follow a known path. Known maximum latency specifications are typically associated with the various bus architectures listed above. Thus, when the

employed interconnect medium is a bus, latencies fall within a known range. In the case of a switch fabric, latencies are fixed. Further, the connections are "direct", rather than by some undetermined path. In general, the use of the distributed interconnect 1080 rather than network connections, permits the switching and interconnect capacities of the content delivery system 1010 to be predictable and consistent.

One example interconnection system suitable for use as distributive interconnection 1080 is an 8/16 port 28.4 Gbps high speed PRIZMA-E non-blocking switch fabric switch available from IBM. It will be understood that other switch fabric configurations having greater or lesser numbers of ports, throughput, and capacity are also possible. Among the advantages offered by such a switch fabric interconnection in comparison to shared-bus interface interconnection technology are throughput, scalability and fast and efficient communication between individual discrete content delivery engines of content delivery system 1010. In the embodiment of FIG. 1A, distributive interconnection 1080 facilitates parallel and independent operation of each engine in its own optimized environment without bandwidth interference from other engines, while at the same time providing peer-to-peer communication between the engines on an as-needed basis (e.g., allowing direct communication between any two content delivery engines 1030, 1040, 1050, 1060 and 1070). Moreover, the distributed interconnect may directly transfer inter-processor communications between the various engines of the system. Thus, communication, command and control information may be provided between the various peers via the distributed interconnect. In addition, communication from one peer to multiple peers may be implemented through a broadcast communication which is provided from one peer to all peers coupled to the interconnect. The interface for each peer may be standardized, thus providing ease of design and allowing for system scaling by providing standardized ports for adding additional peers.

NETWORK INTERFACE PROCESSING ENGINE

As illustrated in FIG. 1A, network interface processing engine 1030 interfaces with network 1020 by receiving and processing requests for content and delivering requested content to network 1020. Network interface processing engine 1030 may be any hardware or hardware/software subsystem suitable for connections utilizing TCP (Transmission Control Protocol) IP (Internet Protocol), UDP (User Datagram Protocol), RTP (Real-Time Transport Protocol), Internet Protocol (IP), Wireless Application Protocol (WAP) as well as other networking protocols. Thus the network interface processing engine 1030 may be suitable

for handling queue management, buffer management, TCP connect sequence, checksum, IP address lookup, internal load balancing, packet switching, *etc.* Thus, network interface processing engine 1030 may be employed as illustrated to process or terminate one or more layers of the network protocol stack and to perform look-up intensive operations, offloading
5 these tasks from other content delivery processing engines of content delivery system 1010. Network interface processing engine 1030 may also be employed to load balance among other content delivery processing engines of content delivery system 1010. Both of these features serve to accelerate content delivery, and are enhanced by placement of distributive interchange and protocol termination processing functions on the same board. Examples of
10 other functions that may be performed by network interface processing engine 1030 include, but are not limited to, security processing.

With regard to the network protocol stack, the stack in traditional systems may often be rather large. Processing the entire stack for every request across the distributed
15 interconnect may significantly impact performance. As described herein, the protocol stack has been segmented or “split” between the network interface engine and the transport processing engine. An abbreviated version of the protocol stack is then provided across the interconnect. By utilizing this functionally split version of the protocol stack, increased bandwidth may be obtained. In this manner the communication and data flow through the
20 content delivery system 1010 may be accelerated. The use of a distributed interconnect (for example a switch fabric) further enhances this acceleration as compared to traditional bus interconnects.

The network interface processing engine 1030 may be coupled to the network 1020
25 through a Gigabit (Gb) Ethernet fiber front end interface 1022. One or more additional Gb Ethernet interfaces 1023 may optionally be provided, for example, to form a second interface with network 1020, or to form an interface with a second network or application 1024 as shown (*e.g.*, to form an interface with one or more server/s for delivery of web cache content, *etc.*). Regardless of whether the network connection is via Ethernet, or some other means, the
30 network connection could be of any type, with other examples being ATM, SONET, or wireless. The physical medium between the network and the network processor may be copper, optical fiber, wireless, *etc.*

In one embodiment, network interface processing engine 1030 may utilize a network processor, although it will be understood that in other embodiments a network processor may be supplemented with or replaced by a general purpose processor or an embedded microcontroller. The network processor may be one of the various types of specialized processors that have been designed and marketed to switch network traffic at intermediate nodes. Consistent with this conventional application, these processors are designed to process high speed streams of network packets. In conventional operation, a network processor receives a packet from a port, verifies fields in the packet header, and decides on an outgoing port to which it forwards the packet. The processing of a network processor may be considered as "pass through" processing, as compared to the intensive state modification processing performed by general purpose processors. A typical network processor has a number of processing elements, some operating in parallel and some in pipeline. Often a characteristic of a network processor is that it may hide memory access latency needed to perform lookups and modifications of packet header fields. A network processor may also have one or more network interface controllers, such as a gigabit Ethernet controller, and are generally capable of handling data rates at "wire speeds".

Examples of network processors include the C-Port processor manufactured by Motorola, Inc., the IXP1200 processor manufactured by Intel Corporation, the Prism processor manufactured by SiTera Inc., and others manufactured by MMC Networks, Inc. and Agere, Inc. These processors are programmable, usually with a RISC or augmented RISC instruction set, and are typically fabricated on a single chip.

The processing cores of a network processor are typically accompanied by special purpose cores that perform specific tasks, such as fabric interfacing, table lookup, queue management, and buffer management. Network processors typically have their memory management optimized for data movement, and have multiple I/O and memory buses. The programming capability of network processors permit them to be programmed for a variety of tasks, such as load balancing, network protocol processing, network security policies, and QoS/CoS support. These tasks can be tasks that would otherwise be performed by another processor. For example, TCP/IP processing may be performed by a network processor at the front end of an endpoint system. Another type of processing that could be offloaded is execution of network security policies or protocols. A network processor could also be used for load balancing. Network processors used in this manner can be referred to as "network

accelerators” because their front end “look ahead” processing can vastly increase network response speeds. Network processors perform look ahead processing by operating at the front end of the network endpoint to process network packets in order to reduce the workload placed upon the remaining endpoint resources. Various uses of network accelerators are described in the following concurrently filed U.S. patent applications: no. 09/797,412
5 entitled “Network Transport Accelerator,” by Bailey et. al; no. 09/797,507 entitled “Single Chassis Network Endpoint System With Network Processor For Load Balancing,” by Richter et. al; and no. 09/797,411 entitled “Network Security Accelerator,” by Canion et. al; the disclosures of which are all incorporated herein by reference.

10

FIG. 3 illustrates one possible general configuration of a network processor. As illustrated, a set of traffic processors 21 operate in parallel to handle transmission and receipt of network traffic. These processors may be general purpose microprocessors or state machines. Various core processors 22 - 24 handle special tasks. For example, the core
15 processors 22 - 24 may handle lookups, checksums, and buffer management. A set of serial data processors 25 provide Layer 1 network support. Interface 26 provides the physical interface to the network 1020. A general purpose bus interface 27 is used for downloading code and configuration tasks. A specialized interface 28 may be specially programmed to optimize the path between network processor 12 and distributed interconnection 1080.

20

As mentioned above, the network processors utilized in the content delivery system 1010 are utilized for endpoint use, rather than conventional use at intermediate network nodes. In one embodiment, network interface processing engine 1030 may utilize a MOTOROLA C-Port C-5 network processor capable of handling two Gb Ethernet interfaces
25 at wire speed, and optimized for cell and packet processing. This network processor may contain sixteen 200 MHz MIPS processors for cell/packet switching and thirty-two serial processing engines for bit/byte processing, checksum generation/verification, etc. Further processing capability may be provided by five co-processors that perform the following network specific tasks: supervisor/executive, switch fabric interface, optimized table lookup, queue management, and buffer management. The network processor may be coupled to the
30 network 1020 by using a VITESSE GbE SERDES (serializer-deserializer) device (for example the VSC7123) and an SFP (small form factor pluggable) optical transceiver for LC fiber connection.

TRANSPORT / PROTOCOL PROCESSING ENGINE

Referring again to FIG. 1A, transport processing engine 1050 may be provided for performing network transport protocol sub-tasks, such as processing content requests received from network interface engine 1030. Although named a "transport" engine for discussion purposes, it will be recognized that the engine 1050 performs transport and protocol processing and the term transport processing engine is not meant to limit the functionality of the engine. In this regard transport processing engine 1050 may be any hardware or hardware/software subsystem suitable for TCP/UDP processing, other protocol processing, transport processing, *etc.* In one embodiment transport engine 1050 may be a dedicated TCP/UDP processing module based on an INTEL PENTIUM III or MOTOROLA POWERPC 7450 based processor running the Thread-X RTOS environment with protocol stack based on TCP/IP technology.

As compared to traditional server type computing systems, the transport processing engine 1050 may off-load other tasks that traditionally a main CPU may perform. For example, the performance of server CPUs significantly decreases when a large amount of network connections are made merely because the server CPU regularly checks each connection for time outs. The transport processing engine 1050 may perform time out checks for each network connection, session management, data reordering and retransmission, data queueing and flow control, packet header generation, *etc.* off-loading these tasks from the application processing engine or the network interface processing engine. The transport processing engine 1050 may also handle error checking, likewise freeing up the resources of other processing engines.

NETWORK INTERFACE / TRANSPORT SPLIT PROTOCOL

The embodiment of FIG. 1A contemplates that the protocol processing is shared between the transport processing engine 1050 and the network interface engine 1030. This sharing technique may be called "split protocol stack" processing. The division of tasks may be such that higher tasks in the protocol stack are assigned to the transport processor engine. For example, network interface engine 1030 may processes all or some of the TCP/IP protocol stack as well as all protocols lower on the network protocol stack. Another approach could be to assign state modification intensive tasks to the transport processing engine.

In one embodiment related to a content delivery system that receives packets, the network interface engine performs the MAC header identification and verification, IP header identification and verification, IP header checksum validation, TCP and UDP header identification and validation, and TCP or UDP checksum validation. It also may perform the
5 lookup to determine the TCP connection or UDP socket (protocol session identifier) to which a received packet belongs. Thus, the network interface engine verifies packet lengths, checksums, and validity. For transmission of packets, the network interface engine performs TCP or UDP checksum generation, IP header generation, and MAC header generation, IP checksum generation, MAC FCS/CRC generation, etc.

10

Tasks such as those described above can all be performed rapidly by the parallel and pipeline processors within a network processor. The “fly by” processing style of a network processor permits it to look at each byte of a packet as it passes through, using registers and other alternatives to memory access. The network processor’s “stateless forwarding”
15 operation is best suited for tasks not involving complex calculations that require rapid updating of state information.

An appropriate internal protocol may be provided for exchanging information between the network interface engine 1030 and the transport engine 1050 when setting up or
20 terminating a TCP and/or UDP connections and to transfer packets between the two engines. For example, where the distributive interconnection medium is a switch fabric, the internal protocol may be implemented as a set of messages exchanged across the switch fabric. These messages indicate the arrival of new inbound or outbound connections and contain inbound or outbound packets on existing connections, along with identifiers or tags for those
25 connections. The internal protocol may also be used to transfer identifiers or tags between the transport engine 1050 and the application processing engine 1070 and/or the storage processing engine 1040. These identifiers or tags may be used to reduce or strip or accelerate a portion of the protocol stack.

30 For example, with a TCP/IP connection, the network interface engine 1030 may receive a request for a new connection. The header information associated with the initial request may be provided to the transport processing engine 1050 for processing. That result of this processing may be stored in the resources of the transport processing engine 1050 as state and management information for that particular network session. The transport

processing engine 1050 then informs the network interface engine 1030 as to the location of these results. Subsequent packets related to that connection that are processed by the network interface engine 1030 may have some of the header information stripped and replaced with an identifier or tag that is provided to the transport processing engine 1050. The identifier or tag
5 may be a pointer, index or any other mechanism that provides for the identification of the location in the transport processing engine of the previously setup state and management information (or the corresponding network session). In this manner, the transport processing engine 1050 does not have to process the header information of every packet of a connection. Rather, the transport interface engine merely receives a contextually meaningful identifier or
10 tag that identifies the previous processing results for that connection.

In one embodiment, the data link, network, transport and session layers (layers 2-5) of a packet may be replaced by identifier or tag information. For packets related to an established connection the transport processing engine does not have to perform intensive
15 processing with regard to these layers such as hashing, scanning, look up, etc. operations. Rather, these layers have already been converted (or processed) once in the transport processing engine and the transport processing engine just receives the identifier or tag provided from the network interface engine that identifies the location of the conversion results.

20

In this manner an identifier or tag is provided for each packet of an established connection so that the more complex data computations of converting header information may be replaced with a more simplistic analysis of an identifier or tag. The delivery of content is thereby accelerated, as the time for packet processing and the amount of system
25 resources for packet processing are both reduced. The functionality of network processors, which provide efficient parallel processing of packet headers, is well suited for enabling the acceleration described herein. In addition, acceleration is further provided as the physical size of the packets provided across the distributed interconnect may be reduced.

30 Though described herein with reference to messaging between the network interface engine and the transport processing engine, the use of identifiers or tags may be utilized amongst all the engines in the modular pipelined processing described herein. Thus, one engine may replace packet or data information with contextually meaningful information that may require less processing by the next engine in the data and communication flow path. In

addition, these techniques may be utilized for a wide variety of protocols and layers, not just the exemplary embodiments provided herein.

With the above-described tasks being performed by the network interface engine, the
5 transport engine may perform TCP sequence number processing, acknowledgement and retransmission, segmentation and reassembly, and flow control tasks. These tasks generally call for storing and modifying connection state information on each TCP and UDP connection, and therefore are considered more appropriate for the processing capabilities of general purpose processors.

10

As will be discussed with references to alternative embodiments (such as FIGS. 2 and 2A), the transport engine 1050 and the network interface engine 1030 may be combined into a single engine. Such a combination may be advantageous as communication across the switch fabric is not necessary for protocol processing. However, limitations of many
15 commercially available network processors make the split protocol stack processing described above desirable.

APPLICATION PROCESSING ENGINE

Application processing engine 1070 may be provided in content delivery system 1010
20 for application processing, and may be, for example, any hardware or hardware/software subsystem suitable for session layer protocol processing (*e.g.*, HTTP, RTSP streaming, *etc.*) of content requests received from network transport processing engine 1050. In one embodiment application processing engine 1070 may be a dedicated application processing module based on an INTEL PENTIUM III processor running, for example, on standard x86
25 OS systems (*e.g.*, Linux, Windows NT, FreeBSD, *etc.*). Application processing engine 1070 may be utilized for dedicated application-only processing by virtue of the off-loading of all network protocol and storage processing elsewhere in content delivery system 1010. In one embodiment, processor programming for application processing engine 1070 may be generally similar to that of a conventional server, but without the tasks off-loaded to network
30 interface processing engine 1030, storage processing engine 1040, and transport processing engine 1050.

STORAGE MANAGEMENT ENGINE

Storage management engine 1040 may be any hardware or hardware/software subsystem suitable for effecting delivery of requested content from content sources (for example content sources 1090 and/or 1100) in response to processed requests received from application processing engine 1070. It will also be understood that in various embodiments a storage management engine 1040 may be employed with content sources other than disk drives (*e.g.*, solid state storage, the storage systems described above, or any other media suitable for storage of data) and may be programmed to request and receive data from these other types of storage.

In one embodiment, processor programming for storage management engine 1040 may be optimized for data retrieval using techniques such as caching, and may include and maintain a disk cache to reduce the relatively long time often required to retrieve data from content sources, such as disk drives. Requests received by storage management engine 1040 from application processing engine 1070 may contain information on how requested data is to be formatted and its destination, with this information being comprehensible to transport processing engine 1050 and/or network interface processing engine 1030. The storage management engine 1040 may utilize a disk cache to reduce the relatively long time it may take to retrieve data stored in a storage medium such as disk drives. Upon receiving a request, storage management engine 1040 may be programmed to first determine whether the requested data is cached, and then to send a request for data to the appropriate content source 1090 or 1100. Such a request may be in the form of a conventional read request. The designated content source 1090 or 1100 responds by sending the requested content to storage management engine 1040, which in turn sends the content to transport processing engine 1050 for forwarding to network interface processing engine 1030.

Based on the data contained in the request received from application processing engine 1070, storage processing engine 1040 sends the requested content in proper format with the proper destination data included. Direct communication between storage processing engine 1040 and transport processing engine 1050 enables application processing engine 1070 to be bypassed with the requested content. Storage processing engine 1040 may also be configured to write data to content sources 1090 and/or 1100 (*e.g.*, for storage of live or broadcast streaming content).

In one embodiment storage management engine 1040 may be a dedicated block-level cache processor capable of block level cache processing in support of thousands of concurrent multiple readers, and direct block data switching to network interface engine 1030. In this regard storage management engine 1040 may utilize a POWER PC 7450 processor in conjunction with ECC memory and a LSI SYMFC929 dual 2GBaud fibre channel controller for fibre channel interconnect to content sources 1090 and/or 1100 via dual fibre channel arbitrated loop 1092. It will be recognized, however, that other forms of interconnection to storage sources suitable for retrieving content are also possible. Storage management engine 1040 may include hardware and/or software for running the Fibre Channel (FC) protocol, the SCSI (Small Computer Systems Interface) protocol, iSCSI protocol as well as other storage networking protocols.

Storage management engine 1040 may employ any suitable method for caching data, including simple computational caching algorithms such as random removal (RR), first-in first-out (FIFO), predictive read-ahead, over buffering, etc. algorithms. Other suitable caching algorithms include those that consider one or more factors in the manipulation of content stored within the cache memory, or which employ multi-level ordering, key based ordering or function based calculation for replacement. In one embodiment, storage management engine may implement a layered multiple LRU (LMLRU) algorithm that uses an integrated block/buffer management structure including at least two layers of a configurable number of multiple LRU queues and a two-dimensional positioning algorithm for data blocks in the memory to reflect the relative priorities of a data block in the memory in terms of both recency and frequency. Such a caching algorithm is described in further detail in concurrently filed U.S. patent application no. 09/797,198 entitled "Systems and Methods for Management of Memory" by Qiu et. al, the disclosure of which is incorporated herein by reference.

For increasing delivery efficiency of continuous content, such as streaming multimedia content, storage management engine 1040 may employ caching algorithms that consider the dynamic characteristics of continuous content. Suitable examples include, but are not limited to, interval caching algorithms. In one embodiment, improved caching performance of continuous content may be achieved using an LMLRU caching algorithm that weighs ongoing viewer cache value versus the dynamic time-size cost of maintaining particular content in cache memory. Such a caching algorithm is described in further detail in

concurrently filed U.S. patent application no. 09/797,201 entitled "Systems and Methods for Management of Memory in Information Delivery Environments" by Qiu et. al, the disclosure of which is incorporated herein by reference.

5 SYSTEM MANAGEMENT ENGINE

System management (or host) engine 1060 may be present to perform system management functions related to the operation of content delivery system 1010. Examples of system management functions include, but are not limited to, content provisioning/updates, comprehensive statistical data gathering and logging for sub-system engines, collection of
10 shared user bandwidth utilization and content utilization data that may be input into billing and accounting systems, "on the fly" ad insertion into delivered content, customer programmable sub-system level quality of service ("QoS") parameters, remote management (e.g., SNMP, web-based, CLI), health monitoring, clustering controls, remote/local disaster recovery functions, predictive performance and capacity planning, etc. In one embodiment,
15 content delivery bandwidth utilization by individual content suppliers or users (e.g., individual supplier/user usage of distributive interchange and/or content delivery engines) may be tracked and logged by system management engine 1060, enabling an operator of the content delivery system 1010 to charge each content supplier or user on the basis of content volume delivered.

20

System management engine 1060 may be any hardware or hardware/software subsystem suitable for performance of one or more such system management engines and in one embodiment may be a dedicated application processing module based, for example, on an INTEL PENTIUM III processor running an x86 OS. Because system management engine
25 1060 is provided as a discrete modular engine, it may be employed to perform system management functions from within content delivery system 1010 without adversely affecting the performance of the system. Furthermore, the system management engine 1060 may maintain information on processing engine assignment and content delivery paths for various content delivery applications, substantially eliminating the need for an individual processing
30 engine to have intimate knowledge of the hardware it intends to employ.

Under manual or scheduled direction by a user, system management processing engine 1060 may retrieve content from the network 1020 or from one or more external servers on a second network 1024 (e.g., LAN) using, for example, network file system (NFS)

or common internet file system (CIFS) file sharing protocol. Once content is retrieved, the content delivery system may advantageously maintain an independent copy of the original content, and therefore is free to employ any file system structure that is beneficial, and need not understand low level disk formats of a large number of file systems.

5

Management interface 1062 may be provided for interconnecting system management engine 1060 with a network 1200 (*e.g.*, LAN), or connecting content delivery system 1010 to other network appliances such as other content delivery systems 1010, servers, computers, *etc.* Management interface 1062 may be by any suitable network interface, such as 10/100
10 Ethernet, and may support communications such as management and origin traffic. Provision for one or more terminal management interfaces (not shown) for may also be provided, such as by RS-232 port, *etc.* The management interface may be utilized as a secure port to provide system management and control information to the content delivery system 1010. For example, tasks which may be accomplished through the management interface 1062 include
15 reconfiguration of the allocation of system hardware (as discussed below with reference to FIGS. 1C-1F), programming the application processing engine, diagnostic testing, and any other management or control tasks. Though generally content is not envisioned being provided through the management interface, the identification of or location of files or systems containing content may be received through the management interface 1062 so that
20 the content delivery system may access the content through the other higher bandwidth interfaces.

MANAGEMENT PERFORMED BY THE NETWORK INTEFACE

Some of the system management functionality may also be performed directly within
25 the network interface processing engine 1030. In this case some system policies and filters may be executed by the network interface engine 1030 in real-time at wirespeed. These polices and filters may manage some traffic / bandwidth management criteria and various service level guarantee policies. Examples of such system management functionality of are described below. It will be recognized that these functions may be performed by the system
30 management engine 1060, the network interface engine 1030, or a combination thereof.

For example, a content delivery system may contain data for two web sites. An operator of the content delivery system may guarantee one web site (“the higher quality site”) higher performance or bandwidth than the other web site (“the lower quality site”),

presumably in exchange for increased compensation from the higher quality site. The network interface processing engine 1030 may be utilized to determine if the bandwidth limits for the lower quality site have been exceeded and reject additional data requests related to the lower quality site. Alternatively, requests related to the lower quality site may be rejected to ensure the guaranteed performance of the higher quality site is achieved. In this manner the requests may be rejected immediately at the interface to the external network and additional resources of the content delivery system need not be utilized. In another example, storage service providers may use the content delivery system to charge content providers based on system bandwidth of downloads (as opposed to the traditional storage area based fees). For billing purposes, the network interface engine may monitor the bandwidth use related to a content provider. The network interface engine may also reject additional requests related to content from a content provider whose bandwidth limits have been exceeded. Again, in this manner the requests may be rejected immediately at the interface to the external network and additional resources of the content delivery system need not be utilized.

Additional system management functionality, such as quality of service (QoS) functionality, also may be performed by the network interface engine. A request from the external network to the content delivery system may seek a specific file and also may contain Quality of Service (QoS) parameters. In one example, the QoS parameter may indicate the priority of service that a client on the external network is to receive. The network interface engine may recognize the QoS data and the data may then be utilized when managing the data and communication flow through the content delivery system. The request may be transferred to the storage management engine to access this file via a read queue, e.g., [Destination IP][Filename][File Type (CoS)][Transport Priorities (QoS)]. All file read requests may be stored in a read queue. Based on CoS/QoS policy parameters as well as buffer status within the storage management engine (empty, full, near empty, block seq#, etc), the storage management engine may prioritize which blocks of which files to access from the disk next, and transfer this data into the buffer memory location that has been assigned to be transmitted to a specific IP address. Thus based upon QoS data in the request provided to the content delivery system, the data and communication traffic through the system may be prioritized. The QoS and other policy priorities may be applied to both incoming and outgoing traffic flow. Therefore a request having a higher QoS priority may

be received after a lower order priority request, yet the higher priority request may be served data before the lower priority request.

The network interface engine may also be used to filter requests that are not supported
5 by the content delivery system. For example, if a content delivery system is configured only to accept HTTP requests, then other requests such as FTP, telnet, etc. may be rejected or filtered. This filtering may be applied directly at the network interface engine, for example by programming a network processor with the appropriate system policies. Limiting undesirable traffic directly at the network interface offloads such functions from the other
10 processing modules and improves system performance by limiting the consumption of system resources by the undesirable traffic. It will be recognized that the filtering example described herein is merely exemplary and many other filter criteria or policies may be provided.

MULTI-PROCESSOR MODULE DESIGN

As illustrated in FIG. 1A, any given processing engine of content delivery system
15 1010 may be optionally provided with multiple processing modules so as to enable parallel or redundant processing of data and/or communications. For example, two or more individual dedicated TCP/UDP processing modules 1050a and 1050b may be provided for transport processing engine 1050, two or more individual application processing modules 1070a and
20 1070b may be provided for network application processing engine 1070, two or more individual network interface processing modules 1030a and 1030b may be provided for network interface processing engine 1030 and two or more individual storage management processing modules 1040a and 1040b may be provided for storage management processing engine 1040. Using such a configuration, a first content request may be processed between a
25 first TCP/UDP processing module and a first application processing module via a first switch fabric path, at the same time a second content request is processed between a second TCP/UDP processing module and a second application processing module via a second switch fabric path. Such parallel processing capability may be employed to accelerate content delivery.

30

Alternatively, or in combination with parallel processing capability, a first TCP/UDP processing module 1050a may be backed-up by a second TCP/UDP processing module 1050b that acts as an automatic failover spare to the first module 1050a. In those embodiments employing multiple-port switch fabrics, various combinations of multiple

modules may be selected for use as desired on an individual system-need basis (*e.g.*, as may be dictated by module failures and/or by anticipated or actual bottlenecks), limited only by the number of available ports in the fabric. This feature offers great flexibility in the operation of individual engines and discrete processing modules of a content delivery system, which may be translated into increased content delivery acceleration and reduction or substantial elimination of adverse effects resulting from system component failures.

In yet other embodiments, the processing modules may be specialized to specific applications, for example, for processing and delivering HTTP content, processing and delivering RTSP content, or other applications. For example, in such an embodiment an application processing module 1070a and storage processing module 1040a may be specially programmed for processing a first type of request received from a network. In the same system, application processing module 1070b and storage processing module 1040b may be specially programmed to handle a second type of request different from the first type. Routing of requests to the appropriate respective application and/or storage modules may be accomplished using a distributive interconnect and may be controlled by transport and/or interface processing modules as requests are received and processed by these modules using policies set by the system management engine.

Further, by employing processing modules capable of performing the function of more than one engine in a content delivery system, the assigned functionality of a given module may be changed on an as-needed basis, either manually or automatically by the system management engine upon the occurrence of given parameters or conditions. This feature may be achieved, for example, by using similar hardware modules for different content delivery engines (*e.g.*, by employing PENTIUM III based processors for both network transport processing modules and for application processing modules), or by using different hardware modules capable of performing the same task as another module through software programmability (*e.g.*, by employing a POWER PC processor based module for storage management modules that are also capable of functioning as network transport modules). In this regard, a content delivery system may be configured so that such functionality reassignments may occur during system operation, at system boot-up or in both cases. Such reassignments may be effected, for example, using software so that in a given content delivery system every content delivery engine (or at a lower level, every discrete content delivery processing module) is potentially dynamically reconfigurable using software

commands. Benefits of engine or module reassignment include maximizing use of hardware resources to deliver content while minimizing the need to add expensive hardware to a content delivery system.

5 Thus, the system disclosed herein allows various levels of load balancing to satisfy a work request. At a system hardware level, the functionality of the hardware may be assigned in a manner that optimizes the system performance for a given load. At the processing engine level, loads may be balanced between the multiple processing modules of a given processing engine to further optimize the system performance.

10

CLUSTERS OF SYSTEMS

The systems described herein may also be clustered together in groups of two or more to provide additional processing power, storage connections, bandwidth, etc. Communication between two individual systems each configured similar to content delivery system 1010 may
15 be made through network interface 1022 and/or 1023. Thus, one content delivery system could communicate with another content delivery system through the network 1020 and/or 1024. For example, a storage unit in one content delivery system could send data to a network interface engine of another content delivery system. As an example, these communications could be via TCP/IP protocols. Alternatively, the distributed interconnects
20 1080 of two content delivery systems 1010 may communicate directly. For example, a connection may be made directly between two switch fabrics, each switch fabric being the distributed interconnect 1080 of separate content delivery systems 1010.

FIGS. 1G-1J illustrate four exemplary clusters of content delivery systems 1010. It
25 will be recognized that many other cluster arrangements may be utilized including more or less content delivery systems. As shown in FIGS. 1G-1J, each content delivery system may be configured as described above and include a distributive interconnect 1080 and a network interface processing engine 1030. Interfaces 1022 may connect the systems to a network 1020. As shown in FIG. 1G, two content delivery systems may be coupled together through
30 the interface 1023 that is connected to each system's network interface processing engine 1030. FIG. 1H shows three systems coupled together as in FIG. 1G. The interfaces 1023 of each system may be coupled directly together as shown, may be coupled together through a network or may be coupled through a distributed interconnect (for example a switch fabric).

FIG. 1I illustrates a cluster in which the distributed interconnects 1080 of two systems are directly coupled together through an interface 1500. Interface 1500 may be any communication connection, such as a copper connection, optical fiber, wireless connection, etc. Thus, the distributed interconnects of two or more systems may directly communicate
5 without communication through the processor engines of the content delivery systems 1010. FIG. 1J illustrates the distributed interconnects of three systems directly communicating without first requiring communication through the processor engines of the content delivery systems 1010. As shown in FIG. 1J, the interfaces 1500 each communicate with each other through another distributed interconnect 1600. Distributed interconnect 1600 may be a
10 switched fabric or any other distributed interconnect.

The clustering techniques described herein may also be implemented through the use of the management interface 1062. Thus, communication between multiple content delivery systems 1010 also may be achieved through the management interface 1062
15

EXEMPLARY DATA AND COMMUNICATION FLOW PATHS

FIG. 1B illustrates one exemplary data and communication flow path configuration among modules of one embodiment of content delivery system 1010. The flow paths shown in FIG. 1B are just one example given to illustrate the significant improvements in data
20 processing capacity and content delivery acceleration that may be realized using multiple content delivery engines that are individually optimized for different layers of the software stack and that are distributively interconnected as disclosed herein. The illustrated embodiment of FIG. 1B employs two network application processing modules 1070a and 1070b, and two network transport processing modules 1050a and 1050b that are
25 communicatively coupled with single storage management processing module 1040a and single network interface processing module 1030a. The storage management processing module 1040a is in turn coupled to content sources 1090 and 1100. In FIG. 1B, inter-processor command or control flow (i.e. incoming or received data request) is represented by dashed lines, and delivered content data flow is represented by solid lines. Command and
30 data flow between modules may be accomplished through the distributive interconnection 1080 (not shown), for example a switch fabric.

As shown in FIG. 1B, a request for content is received and processed by network interface processing module 1030a and then passed on to either of network transport

processing modules 1050a or 1050b for TCP/UDP processing, and then on to respective application processing modules 1070a or 1070b, depending on the transport processing module initially selected. After processing by the appropriate network application processing module, the request is passed on to storage management processor 1040a for processing and retrieval of the requested content from appropriate content sources 1090 and/or 1100. Storage management processing module 1040a then forwards the requested content directly to one of network transport processing modules 1050a or 1050b, utilizing the capability of distributive interconnection 1080 to bypass network application processing modules 1070a and 1070b. The requested content may then be transferred via the network interface processing module 1030a to the external network 1020. Benefits of bypassing the application processing modules with the delivered content include accelerated delivery of the requested content and offloading of workload from the application processing modules, each of which translate into greater processing efficiency and content delivery throughput. In this regard, throughput is generally measured in sustained data rates passed through the system and may be measured in bits per second. Capacity may be measured in terms of the number of files that may be partially cached, the number of TCP/IP connections per second as well as the number of concurrent TCP/IP connections that may be maintained or the number of simultaneous streams of a certain bit rate. In an alternative embodiment, the content may be delivered from the storage management processing module to the application processing module rather than bypassing the application processing module. This data flow may be advantageous if additional processing of the data is desired. For example, it may be desirable to decode or encode the data prior to delivery to the network.

To implement the desired command and content flow paths between multiple modules, each module may be provided with means for identification, such as a component ID. Components may be affiliated with content requests and content delivery to effect a desired module routing. The data-request generated by the network interface engine may include pertinent information such as the component ID of the various modules to be utilized in processing the request. For example, included in the data request sent to the storage management engine may be the component ID of the transport engine that is designated to receive the requested content data. When the storage management engine retrieves the data from the storage device and is ready to send the data to the next engine, the storage management engine knows which component ID to send the data to.

As further illustrated in FIG. 1B, the use of two network transport modules in conjunction with two network application processing modules provides two parallel processing paths for network transport and network application processing, allowing simultaneous processing of separate content requests and simultaneous delivery of separate content through the parallel processing paths, further increasing throughput/capacity and accelerating content delivery. Any two modules of a given engine may communicate with separate modules of another engine or may communicate with the same module of another engine. This is illustrated in FIG. 1B where the transport modules are shown to communicate with separate application modules and the application modules are shown to communicate with the same storage management module.

FIG. 1B illustrates only one exemplary embodiment of module and processing flow path configurations that may be employed using the disclosed method and system. Besides the embodiment illustrated in FIG. 1B, it will be understood that multiple modules may be additionally or alternatively employed for one or more other network content delivery engines (*e.g.*, storage management processing engine, network interface processing engine, system management processing engine, *etc.*) to create other additional or alternative parallel processing flow paths, and that any number of modules (*e.g.*, greater than two) may be employed for a given processing engine or set of processing engines so as to achieve more than two parallel processing flow paths. For example, in other possible embodiments, two or more different network transport processing engines may pass content requests to the same application unit, or vice-versa.

Thus, in addition to the processing flow paths illustrated in FIG. 1B, it will be understood that the disclosed distributive interconnection system may be employed to create other custom or optimized processing flow paths (*e.g.*, by bypassing and/or interconnecting any given number of processing engines in desired sequence/s) to fit the requirements or desired operability of a given content delivery application. For example, the content flow path of FIG. 1B illustrates an exemplary application in which the content is contained in content sources 1090 and/or 1100 that are coupled to the storage processing engine 1040. However as discussed above with reference to FIG. 1A, remote and/or live broadcast content may be provided to the content delivery system from the networks 1020 and/or 1024 via the second network interface connection 1023. In such a situation the content may be received by the network interface engine 1030 over interface connection 1023 and immediately re-

broadcast over interface connection 1022 to the network 1020. Alternatively, content may be proceed through the network interface connection 1023 to the network transport engine 1050 prior to returning to the network interface engine 1030 for re-broadcast over interface connection 1022 to the network 1020 or 1024. In yet another alternative, if the content
5 requires some manner of application processing (for example encoded content that may need to be decoded), the content may proceed all the way to the application engine 1070 for processing. After application processing the content may then be delivered through the network transport engine 1050, network interface engine 1030 to the network 1020 or 1024.

10 In yet another embodiment, at least two network interface modules 1030a and 1030b may be provided, as illustrated in FIG. 1A. In this embodiment, a first network interface engine 1030a may receive incoming data from a network and pass the data directly to the second network interface engine 1030b for transport back out to the same or different network. For example, in the remote or live broadcast application described above, first
15 network interface engine 1030a may receive content, and second network interface engine 1030b provide the content to the network 1020 to fulfill requests from one or more clients for this content. Peer-to-peer level communication between the two network interface engines allows first network interface engine 1030a to send the content directly to second network interface engine 1030b via distributive interconnect 1080. If necessary, the content may also
20 be routed through transport processing engine 1050, or through transport processing engine 1050 and application processing engine 1070, in a manner described above.

Still yet other applications may exist in which the content required to be delivered is contained both in the attached content sources 1090 or 1100 and at other remote content
25 sources. For example in a web caching application, not all content may be cached in the attached content sources, but rather some data may also be cached remotely. In such an application, the data and communication flow may be a combination of the various flows described above for content provided from the content sources 1090 and 1100 and for content provided from remote sources on the networks 1020 and/or 1024.

30

The content delivery system 1010 described above is configured in a peer-to-peer manner that allows the various engines and modules to communicate with each other directly as peers through the distributed interconnect. This is contrasted with a traditional server architecture in which there is a main CPU. Furthermore unlike the arbitrated bus of

traditional servers, the distributed interconnect 1080 provides a switching means which is not arbitrated and allows multiple simultaneous communications between the various peers. The data and communication flow may by-pass unnecessary peers such as the return of data from the storage management processing engine 1040 directly to the network interface processing engine 1030 as described with reference to FIG. 1B.

Communications between the various processor engines may be made through the use of a standardized internal protocol. Thus, a standardized method is provided for routing through the switch fabric and communicating between any two of the processor engines which operate as peers in the peer to peer environment. The standardized internal protocol provides a mechanism upon which the external network protocols may "ride" upon or be incorporated within. In this manner additional internal protocol layers relating to internal communication and data exchange may be added to the external protocol layers. The additional internal layers may be provided in addition to the external layers or may replace some of the external protocol layers (for example as described above portions of the external headers may be replaced by identifiers or tags by the network interface engine).

The standardized internal protocol may consist of a system of message classes, or types, where the different classes can independently include fields or layers that are utilized to identify the destination processor engine or processor module for communication, control, or data messages provided to the switch fabric along with information pertinent to the corresponding message class. The standardized internal protocol may also include fields or layers that identify the priority that a data packet has within the content delivery system. These priority levels may be set by each processing engine based upon system-wide policies. Thus, some traffic within the content delivery system may be prioritized over other traffic and this priority level may be directly indicated within the internal protocol call scheme utilized to enable communications within the system. The prioritization helps enable the predictive traffic flow between engines and end-to-end through the system such that service level guarantees may be supported.

30

Other internally added fields or layers may include processor engine state, system timestamps, specific message class identifiers for message routing across the switch fabric and at the receiving processor engine(s), system keys for secure control message exchange, flow control information to regulate control and data traffic flow and prevent congestion, and

specific address tag fields that allow hardware at the receiving processor engines to move specific types of data directly into system memory.

In one embodiment, the internal protocol may be structured as a set, or system of
5 messages with common system defined headers that allows all processor engines and, potentially, processor engine switch fabric attached hardware, to interpret and process messages efficiently and intelligently. This type of design allows each processing engine, and specific functional entities within the processor engines, to have their own specific message classes optimized functionally for the exchanging their specific types control and data
10 information. Some message classes that may be employed are: System Control messages for system management, Network Interface to Network Transport messages, Network Transport to Application Interface messages, File System to Storage engine messages, Storage engine to Network Transport messages, etc. Some of the fields of the standardized message header may include message priority, message class, message class identifier (subtype), message size,
15 message options and qualifier fields, message context identifiers or tags, etc. In addition, the system statistics gathering, management and control of the various engines may be performed across the switch fabric connected system using the messaging capabilities.

By providing a standardized internal protocol, overall system performance may be
20 improved. In particular, communication speed between the processor engines across the switch fabric may be increased. Further, communications between any two processor engines may be enabled. The standardized protocol may also be utilized to reduce the processing loads of a given engine by reducing the amount of data that may need to be processed by a given engine.

25

The internal protocol may also be optimized for a particular system application, providing further performance improvements. However, the standardized internal communication protocol may be general enough to support encapsulation of a wide range of networking and storage protocols. Further, while internal protocol may run on PCI, PCI-X,
30 ATM, IB, Lightning I/O, the internal protocol is a protocol above these transport-level standards and is optimal for use in a switched (non-bus) environment such as a switch fabric. In addition, the internal protocol may be utilized to communicate devices (or peers) connected to the system in addition to those described herein. For example, a peer need not be a processing engine. In one example, a peer may be an ASIC protocol converter that is

coupled to the distributed interconnect as a peer but operates as a slave device to other master devices within the system. The internal protocol may also be as a protocol communicated between systems such as used in the clusters described above.

5 Thus a system has been provided in which the networking / server clustering / storage networking has been collapsed into a single system utilizing a common low-overhead internal communication protocol / transport system.

CONTENT DELIVERY ACCELERATION

10 As described above, a wide range of techniques have been provided for accelerating content delivery from the content delivery system 1010 to a network. By accelerating the speed at which content may be delivered, a more cost effective and higher performance system may be provided. These techniques may be utilized separately or in various combinations.

15

 One content acceleration technique involves the use of a multi-engine system with dedicated engines for varying processor tasks. Each engine can perform operations independently and in parallel with the other engines without the other engines needing to freeze or halt operations. The engines do not have to compete for resources such as memory,
20 I/O, processor time, etc. but are provided with their own resources. Each engine may also be tailored in hardware and/or software to perform specific content delivery task, thereby providing increasing content delivery speeds while requiring less system resources. Further, all data, regardless of the flow path, gets processed in a staged pipeline fashion such that each engine continues to process its layer of functionality after forwarding data to the next engine /
25 layer.

 Content acceleration is also obtained from the use of multiple processor modules within an engine. In this manner, parallelism may be achieved within a specific processing engine. Thus, multiple processors responding to different content requests may be operating
30 in parallel within one engine.

 Content acceleration is also provided by utilizing the multi-engine design in a peer to peer environment in which each engine may communicate as a peer. Thus, the communications and data paths may skip unnecessary engines. For example, data may be

communicated directly from the storage processing engine to the transport processing engine without have to utilize resources of the application processing engine.

Acceleration of content delivery is also achieved by removing or stripping the
5 contents of some protocol layers in one processing engine and replacing those layers with
identifiers or tags for use with the next processor engine in the data or communications flow
path. Thus, the processing burden placed on the subsequent engine may be reduced. In
addition, the packet size transmitted across the distributed interconnect may be reduced.
Moreover, protocol processing may be off-loaded from the storage and/or application
10 processors, thus freeing those resources to focus on storage or application processing.

Content acceleration is also provided by using network processors in a network
endpoint system. Network processors generally are specialized to perform packet analysis
functions at intermediate network nodes, but in the content delivery system disclosed the
15 network processors have been adapted for endpoint functions. Furthermore, the parallel
processor configurations within a network processor allow these endpoint functions to be
performed efficiently.

In addition, content acceleration has been provided through the use of a distributed
20 interconnection such as a switch fabric. A switch fabric allows for parallel communications
between the various engines and helps to efficiently implement some of the acceleration
techniques described herein.

It will be recognized that other aspects of the content delivery system 1010 also
25 provide for accelerated delivery of content to a network connection. Further, it will be
recognized that the techniques disclosed herein may be equally applicable to other network
endpoint systems and even non-endpoint systems.

EXEMPLARY HARDWARE EMBODIMENTS

30 FIGS. 1C-1F illustrate just a few of the many multiple network content delivery
engine configurations possible with one exemplary hardware embodiment of content delivery
system 1010. In each illustrated configuration of this hardware embodiment, content delivery
system 1010 includes processing modules that may be configured to operate as content
delivery engines 1030, 1040, 1050, 1060, and 1070 communicatively coupled via distributive

interconnection 1080. As shown in FIG. 1C, a single processor module may operate as the network interface processing engine 1030 and a single processor module may operate as the system management processing engine 1060. Four processor modules 1001 may be configured to operate as either the transport processing engine 1050 or the application processing engine 1070. Two processor modules 1003 may operate as either the storage processing engine 1040 or the transport processing engine 1050. The Gigabit (Gb) Ethernet front end interface 1022, system management interface 1062 and dual fibre channel arbitrated loop 1092 are also shown.

As mentioned above, the distributive interconnect 1080 may be a switch fabric based interconnect. As shown in FIG. 1C, the interconnect may be an IBM PRIZMA-E eight/sixteen port switch fabric 1081. In an eight port mode, this switch fabric is an 8 x 3.54 Gbps fabric and in a sixteen port mode, this switch fabric is a 16 x 1.77 Gbps fabric. The eight/sixteen port switch fabric may be utilized in an eight port mode for performance optimization. The switch fabric 1081 may be coupled to the individual processor modules through interface converter circuits 1082, such as IBM UDASL switch interface circuits. The interface converter circuits 1082 convert the data aligned serial link interface (DASL) to a UTOPIA (Universal Test and Operations PHY Interface for ATM) parallel interface. FPGAs (field programmable gate array) may be utilized in the processor modules as a fabric interface on the processor modules as shown in FIG. 1C. These fabric interfaces provide a 64/66Mhz PCI interface to the interface converter circuits 1082. FIG. 4 illustrates a functional block diagram of such a fabric interface 34. As explained below, the interface 34 provides an interface between the processor module bus and the UDASL switch interface converter circuit 1082. As shown in FIG. 4, at the switch fabric side, a physical connection interface 41 provides connectivity at the physical level to the switch fabric. An example of interface 41 is a parallel bus interface complying with the UTOPIA standard. In the example of FIG. 4, interface 41 is a UTOPIA 3 interface providing a 32-bit 110 Mhz connection. However, the concepts disclosed herein are not protocol dependent and the switch fabric need not comply with any particular ATM or non ATM standard.

30

Still referring to FIG. 4, SAR (segmentation and reassembly) unit 42 has appropriate SAR logic 42a for performing segmentation and reassembly tasks for converting messages to fabric cells and vice-versa as well as message classification and message class-to-queue routing, using memory 42b and 42c for transmit and receive queues. This permits different

classes of messages and permits the classes to have different priority. For example, control messages can be classified separately from data messages, and given a different priority. All fabric cells and the associated messages may be self routing, and no out of band signaling is required.

5

A special memory modification scheme permits one processor module to write directly into memory of another. This feature is facilitated by switch fabric interface 34 and in particular by its message classification capability. Commands and messages follow the same path through switch fabric interface 34, but can be differentiated from other control and data messages. In this manner, processes executing on processor modules can communicate directly using their own memory spaces.

Bus interface 43 permits switch fabric interface 34 to communicate with the processor of the processor module via the module device or I/O bus. An example of a suitable bus architecture is a PCI architecture, but other architectures could be used. Bus interface 43 is a master/target device, permitting interface 43 to write and be written to and providing appropriate bus control. The logic circuitry within interface 43 implements a state machine that provides the communications protocol, as well as logic for configuration and parity.

Referring again to FIG. 1C, network processor 1032 (for example a MOTOROLA C-Port C-5 network processor) of the network interface processing engine 1030 may be coupled directly to an interface converter circuit 1082 as shown. As mentioned above and further shown in FIG. 1C, the network processor 1032 also may be coupled to the network 1020 by using a VITESSE GbE SERDES (serializer-deserializer) device (for example the VSC7123) and an SFP (small form factor pluggable) optical transceiver for LC fibre connection.

The processor modules 1003 include a fibre channel (FC) controller as mentioned above and further shown in FIG. 1C. For example, the fibre channel controller may be the LSI SYMFC929 dual 2GBaud fibre channel controller. The fibre channel controller enables communication with the fibre channel 1092 when the processor module 1003 is utilized as a storage processing engine 1040. Also illustrated in FIGS. 1C-1F is optional adjunct processing unit 1300 that employs a POWER PC processor with SDRAM. The adjunct processing unit is shown coupled to network processor 1032 of network interface processing

engine 1030 by a PCI interface. Adjunct processing unit 1300 may be employed for monitoring system parameters such as temperature, fan operation, system health, etc.

As shown in FIGS. 1C-1F, each processor module of content delivery engines 1030, 1040, 1050, 1060, and 1070 is provided with its own synchronous dynamic random access memory ("SDRAM") resources, enhancing the independent operating capabilities of each module. The memory resources may be operated as ECC (error correcting code) memory. Network interface processing engine 1030 is also provided with static random access memory ("SRAM"). Additional memory circuits may also be utilized as will be recognized by those skilled in the art. For example, additional memory resources (such as synchronous SRAM and non-volatile FLASH and EEPROM) may be provided in conjunction with the fibre channel controllers. In addition, boot FLASH memory may also be provided on the of the processor modules.

The processor modules 1001 and 1003 of FIG. 1C may be configured in alternative manners to implement the content delivery processing engines such as the network interface processing engine 1030, storage processing engine 1040, transport processing engine 1050, system management processing engine 1060, and application processing engine 1070. Exemplary configurations are shown in FIGS. 1D-1F, however, it will be recognized that other configurations may be utilized.

As shown in FIG. 1D, two Pentium III based processing modules may be utilized as network application processing modules 1070a and 1070b of network application processing engine 1070. The remaining two Pentium III-based processing modules are shown in FIG. 1D configured as network transport / protocol processing modules 1050a and 1050b of network transport / protocol processing engine 1050. The embodiment of FIG. 1D also includes two POWER PC-based processor modules, configured as storage management processing modules 1040a and 1040b of storage management processing engine 1040. A single MOTOROLA C-Port C-5 based network processor is shown employed as network interface processing engine 1030, and a single Pentium III-based processing module is shown employed as system management processing engine 1060.

In FIG. 1E, the same hardware embodiment of FIG. 1C is shown alternatively configured so that three Pentium III-based processing modules function as network

application processing modules 1070a, 1070b and 1070c of network application processing engine 1070, and so that the sole remaining Pentium III-based processing module is configured as a network transport processing module 1050a of network transport processing engine 1050. As shown, the remaining processing modules are configured as in FIG. 1D.

5

In FIG. 1F, the same hardware embodiment of FIG. 1C is shown in yet another alternate configuration so that three Pentium III-based processing modules function as application processing modules 1070a, 1070b and 1070c of network application processing engine 1070. In addition, the network transport processing engine 1050 includes one
10 Pentium III-based processing module that is configured as network transport processing module 1050a, and one POWER PC-based processing module that is configured as network transport processing module 1050b. The remaining POWER PC-based processor module is configured as storage management processing module 1040a of storage management processing engine 1040.

15

It will be understood with benefit of this disclosure that the hardware embodiment and multiple engine configurations thereof illustrated in FIGS. 1C-1F are exemplary only, and that other hardware embodiments and engine configurations thereof are also possible. It will further be understood that in addition to changing the assignments of individual processing
20 modules to particular processing engines, distributive interconnect 1080 enables the various processing flow paths between individual modules employed in a particular engine configuration in a manner as described in relation to FIG. 1B. Thus, for any given hardware embodiment and processing engine configuration, a number of different processing flow paths may be employed so as to optimize system performance to suit the needs of particular
25 system applications.

SINGLE CHASSIS DESIGN

As mentioned above, the content delivery system 1010 may be implemented within a single chassis, such as for example, a 2U chassis. The system may be expanded further while
30 still remaining a single chassis system. In particular, utilizing a multiple processor module or blade arrangement connected through a distributive interconnect (for example a switch fabric) provides a system that is easily scalable. The chassis and interconnect may be configured with expansion slots provided for adding additional processor modules. Additional processor modules may be provided to implement additional applications within

the same chassis. Alternatively, additional processor modules may be provided to scale the bandwidth of the network connection. Thus, though describe with respect to a 1Gbps Ethernet connection to the external network, a 10 Gbps, 40 Gbps or more connection may be established by the system through the use of more network interface modules. Further, 5 additional processor modules may be added to address a system's particular bottlenecks without having to expand all engines of the system. The additional modules may be added during a systems initial configuration, as an upgrade during system maintenance or even hot plugged during system operation.

10 ALTERNATIVE SYSTEMS CONFIGURATIONS

Further, the network endpoint system techniques disclosed herein may be implemented in a variety of alternative configurations that incorporate some, but not necessarily all, of the concepts disclosed herein. For example, FIGS. 2 and 2A disclose two exemplary alternative configurations. It will be recognized, however, that many other 15 alternative configurations may be utilized while still gaining the benefits of the inventions disclosed herein.

FIG. 2 is a more generalized and functional representation of a content delivery system showing how such a system may be alternately configured to have one or more of the 20 features of the content delivery system embodiments illustrated in FIGS. 1A-1F. FIG. 2 shows content delivery system 200 coupled to network 260 from which content requests are received and to which content is delivered. Content sources 265 are shown coupled to content delivery system 200 via a content delivery flow path 263 that may be, for example, a storage area network that links multiple content sources 265. A flow path 203 may be 25 provided to network connection 272, for example, to couple content delivery system 200 with other network appliances, in this case one or more servers 201 as illustrated in FIG. 2.

In FIG. 2 content delivery system 200 is configured with multiple processing and memory modules that are distributively interconnected by inter-process communications path 30 230 and inter-process data movement path 235. Inter-process communications path 230 is provided for receiving and distributing inter-processor command communications between the modules and network 260, and interprocess data movement path 235 is provided for receiving and distributing inter-processor data among the separate modules. As illustrated in FIGS. 1A-1F, the functions of inter-process communications path 230 and inter-process data

movement path 235 may be together handled by a single distributive interconnect 1080 (such as a switch fabric, for example), however, it is also possible to separate the communications and data paths as illustrated in FIG. 2, for example using other interconnect technology.

5 FIG. 2 illustrates a single networking subsystem processor module 205 that is provided to perform the combined functions of network interface processing engine 1030 and transport processing engine 1050 of FIG. 1A. Communication and content delivery between network 260 and networking subsystem processor module 205 are made through network connection 270. For certain applications, the functions of network interface processing
10 engine 1030 and transport processing engine 1050 of FIG. 1A may be so combined into a single module 205 of FIG. 2 in order to reduce the level of communication and data traffic handled by communications path 230 and data movement path 235 (or single switch fabric), without adversely impacting the resources of application processing engine or subsystem module. If such a modification were made to the system of FIG. 1A, content requests may be
15 passed directly from the combined interface/transport engine to network application processing engine 1070 via distributive interconnect 1080. Thus, as previously described the functions of two or more separate content delivery system engines may be combined as desired (*e.g.*, in a single module or in multiple modules of a single processing blade), for example, to achieve advantages in efficiency or cost.

20

In the embodiment of FIG. 2, the function of network application processing engine 1070 of FIG. 1A is performed by application processing subsystem module 225 of FIG. 2 in conjunction with application RAM subsystem module 220 of FIG. 2. System monitor module 240 communicates with server/s 201 through flow path 203 and Gb Ethernet network
25 interface connection 272 as also shown in FIG. 2. The system monitor module 240 may provide the function of the system management engine 1060 of FIG. 1A and/or other system policy / filter functions such as may also be implemented in the network interface processing engine 1030 as described above with reference to FIG. 1A.

30 Similarly, the function of network storage management engine 1040 is performed by storage subsystem module 210 in conjunction with file system cache subsystem module 215. Communication and content delivery between content sources 265 and storage subsystem module 210 are shown made directly through content delivery flowpath 263 through fibre channel interface connection 212. Shared resources subsystem module 255 is shown

provided for access by each of the other subsystem modules and may include, for example, additional processing resources, additional memory resources such as RAM, *etc.*

Additional processing engine capability (*e.g.*, additional system management
5 processing capability, additional application processing capability, additional storage
processing capability, encryption / decryption processing capability, compression /
decompression processing capability, encoding / decoding capability, other processing
capability, *etc.*) may be provided as desired and is represented by other subsystem module
275. Thus, as previously described the functions of a single network processing engine may
10 be sub-divided between separate modules that are distributively interconnected. The sub-
division of network processing engine tasks may also be made for reasons of efficiency or
cost, and/or may be taken advantage of to allow resources (*e.g.*, memory or processing) to be
shared among separate modules. Further, additional shared resources may be made available
to one or more separate modules as desired.

15

Also illustrated in FIG. 2 are optional monitoring agents 245 and resources 250. In
the embodiment of FIG. 2, each monitoring agent 245 may be provided to monitor the
resources 250 of its respective processing subsystem module, and may track utilization of
these resources both within the overall system 200 and within its respective processing
20 subsystem module. Examples of resources that may be so monitored and tracked include, but
are not limited to, processing engine bandwidth, Fibre Channel bandwidth, number of
available drives, IOPS (input/output operations per second) per drive and RAID (redundant
array of inexpensive discs) levels of storage devices, memory available for caching blocks of
data, table lookup engine bandwidth, availability of RAM for connection control structures
25 and outbound network bandwidth availability, shared resources (such as RAM) used by
streaming application on a per-stream basis as well as for use with connection control
structures and buffers, bandwidth available for message passing between subsystems,
bandwidth available for passing data between the various subsystems, *etc.*

30 Information gathered by monitoring agents 245 may be employed for a wide variety
of purposes including for billing of individual content suppliers and/or users for pro-rata use
of one or more resources, resource use analysis and optimization, resource health alarms, *etc.*
In addition, monitoring agents may be employed to enable the deterministic delivery of
content by system 200 as described in concurrently filed, co-pending United States patent

application number 09/797,200 entitled "Systems and Methods for the Deterministic Management of Information," which is incorporated herein by reference.

In operation, content delivery system 200 of FIG. 2 may be configured to wait for a
5 request for content or services prior to initiating content delivery or performing a service. A
request for content, such as a request for access to data, may include, for example, a request
to start a video stream, a request for stored data, *etc.* A request for services may include, for
example, a request for to run an application, to store a file, *etc.* A request for content or
services may be received from a variety of sources. For example, if content delivery system
10 200 is employed as a stream server, a request for content may be received from a client
system attached to a computer network or communication network such as the Internet. In a
larger system environment, e.g., a data center, a request for content or services may be
received from a separate subcomponent or a system management processing engine, that is
responsible for performance of the overall system or from a sub-component that is unable to
15 process the current request. Similarly, a request for content or services may be received by a
variety of components of the receiving system. For example, if the receiving system is a
stream server, networking subsystem processor module 205 might receive a content request.
Alternatively, if the receiving system is a component of a larger system, e.g., a data center,
system management processing engine may be employed to receive the request.

20

Upon receipt of a request for content or services, the request may be filtered by
system monitor 240. Such filtering may serve as a screening agent to filter out requests that
the receiving system is not capable of processing (*e.g.*, requests for file writes from read-only
system embodiments, unsupported protocols, content/services unavailable on system 200,
25 *etc.*). Such requests may be rejected outright and the requestor notified, may be re-directed to
a server 201 or other content delivery system 200 capable of handling the request, or may be
disposed of any other desired manner.

Referring now in more detail to one embodiment of FIG. 2 as may be employed in a
30 stream server configuration, networking processing subsystem module 205 may include the
hardware and/or software used to run TCP/IP (Transmission Control Protocol/Internet
Protocol), UDP/IP (User Datagram Protocol/Internet Protocol), RTP (Real-Time Transport
Protocol), Internet Protocol (IP), Wireless Application Protocol (WAP) as well as other
networking protocols. Network interface connections 270 and 272 may be considered part of

networking subsystem processing module 205 or as separate components. Storage subsystem module 210 may include hardware and/or software for running the Fibre Channel (FC) protocol, the SCSI (Small Computer Systems Interface) protocol, iSCSI protocol as well as other storage networking protocols. FC interface 212 to content delivery flowpath 263 may
5 be considered part of storage subsystem module 210 or as a separate component. File system cache subsystem module 215 may include, in addition to cache hardware, one or more cache management algorithms as well as other software routines.

Application RAM subsystem module 220 may function as a memory allocation
10 subsystem and application processing subsystem module 225 may function as a stream-serving application processor bandwidth subsystem. Among other services, application RAM subsystem module 220 and application processing subsystem module 225 may be used to facilitate such services as the pulling of content from storage and/or cache, the formatting of content into RTSP (Real-Time Streaming Protocol) or another streaming protocol as well the
15 passing of the formatted content to networking subsystem 205.

As previously described, system monitor module 240 may be included in content delivery system 200 to manage one or more of the subsystem processing modules, and may also be used to facilitate communication between the modules.
20

In part to allow communications between the various subsystem modules of content delivery system 200, inter-process communication path 230 may be included in content delivery system 200, and may be provided with its own monitoring agent 245. Inter-process communications path 230 may be a reliable protocol path employing a reliable IPC (Inter-process Communications) protocol. To allow data or information to be passed between the
25 various subsystem modules of content delivery system 200, inter-process data movement path 235 may also be included in content delivery system 200, and may be provided with its own monitoring agent 245. As previously described, the functions of inter-process communications path 230 and inter-process data movement path 235 may be together
30 handled by a single distributive interconnect 1080, that may be a switch fabric configured to support the bandwidth of content being served.

In one embodiment, access to content source 265 may be provided via a content delivery flow path 263 that is a fibre channel storage area network (SAN), a switched

technology. In addition, network connectivity may be provided at network connection 270 (e.g., to a front end network) and/or at network connection 272 (e.g., to a back end network) via switched gigabit Ethernet in conjunction with the switch fabric internal communication system of content delivery system 200. As such, that the architecture illustrated in FIGURE 5 2 may be generally characterized as equivalent to a networking system.

One or more shared resources subsystem modules 255 may also be included in a stream server embodiment of content delivery system 200, for sharing by one or more of the other subsystem modules. Shared resources subsystem module 255 may be monitored by the 10 monitoring agents 245 of each subsystem sharing the resources. The monitoring agents 245 of each subsystem module may also be capable of tracking usage of shared resources 255. As previously described, shared resources may include RAM (Random Access Memory) as well as other types of shared resources.

15 Each monitoring agent 245 may be present to monitor one or more of the resources 250 of its subsystem processing module as well as the utilization of those resources both within the overall system and within the respective subsystem processing module. For example, monitoring agent 245 of storage subsystem module 210 may be configured to monitor and track usage of such resources as processing engine bandwidth, Fibre Channel 20 bandwidth to content delivery flow path 263, number of storage drives attached, number of input/output operations per second (IOPS) per drive and RAID levels of storage devices that may be employed as content sources 265. Monitoring agent 245 of file system cache subsystem module 215 may be employed monitor and track usage of such resources as processing engine bandwidth and memory employed for caching blocks of data. Monitoring 25 agent 245 of networking subsystem processing module 205 may be employed to monitor and track usage of such resources as processing engine bandwidth, table lookup engine bandwidth, RAM employed for connection control structures and outbound network bandwidth availability. Monitoring agent 245 of application processing subsystem module 225 may be employed to monitor and track usage of processing engine bandwidth. 30 Monitoring agent 245 of application RAM subsystem module 220 may be employed to monitor and track usage of shared resource 255, such as RAM, which may be employed by a streaming application on a per-stream basis as well as for use with connection control structures and buffers. Monitoring agent 245 of inter-process communication path 230 may be employed to monitor and track usage of such resources as the bandwidth used for message

passing between subsystems while monitoring agent 245 of inter-process data movement path 235 may be employed to monitor and track usage of bandwidth employed for passing data between the various subsystem modules.

5 The discussion concerning FIG. 2 above has generally been oriented towards a system designed to deliver streaming content to a network such as the Internet using, for example, Real Networks, Quick Time or Microsoft Windows Media streaming formats. However, the disclosed systems and methods may be deployed in any other type of system operable to deliver content, for example, in web serving or file serving system environments. In such
10 environments, the principles may generally remain the same. However for application processing embodiments, some differences may exist in the protocols used to communicate and the method by which data delivery is metered (via streaming protocol, versus TCP/IP windowing).

15 FIG. 2A illustrates an even more generalized network endpoint computing system that may incorporate at least some of the concepts disclosed herein. As shown in Figure 2A, a network endpoint system 10 may be coupled to an external network 11. The external network 11 may include a network switch or router coupled to the front end of the endpoint system 10. The endpoint system 10 may be alternatively coupled to some other intermediate
20 network node of the external network. The system 10 may further include a network engine 9 coupled to an interconnect medium 14. The network engine 9 may include one or more network processors. The interconnect medium 14 may be coupled to a plurality of processor units 13 through interfaces 13a. Each processor unit 13 may optionally be couple to data storage (in the exemplary embodiment shown each unit is couple to data storage). More or
25 less processor units 13 may be utilized than shown in FIG. 2A.

The network engine 9 may be a processor engine that performs all protocol stack processing in a single processor module or alternatively may be two processor modules (such as the network interface engine 1030 and transport engine 1050 described above) in which
30 split protocol stack processing techniques are utilized. Thus, the functionality and benefits of the content delivery system 1010 described above may be obtained with the system 10. The interconnect medium 14 may be a distributive interconnection (for example a switch fabric) as described with reference to FIG. 1A. All of the various computing, processing, communication, and control techniques described above with reference to FIGS. 1A-1F and 2

may be implemented within the system 10. It will therefore be recognized that these techniques may be utilized with a wide variety of hardware and computing systems and the techniques are not limited to the particular embodiments disclosed herein.

5 The system 10 may consist of a variety of hardware configurations. In one configuration the network engine 9 may be a stand-alone device and each processing unit 13 may be a separate server. In another configuration the network engine 9 may be configured within the same chassis as the processing units 13 and each processing unit 13 may be a separate server card or other computing system. Thus, a network engine (for example an
10 engine containing a network processor) may provide transport acceleration and be combined with multi-server functionality within the system 10. The system 10 may also include shared management and interface components. Alternatively, each processing unit 13 may be a processing engine such as the transport processing engine, application engine, storage engine, or system management engine of FIG. 1A. In yet another alternative, each processing unit
15 may be a processor module (or processing blade) of the processor engines shown in the system of FIG. 1A.

FIG. 2B illustrates yet another use of a network engine 9. As shown in FIG. 2B, a network engine 9 may be added to a network interface card 35. The network interface card
20 35 may further include the interconnect medium 14 which may be similar to the distributed interconnect 1080 described above. The network interface card may be part of a larger computing system such as a server. The network interface card may couple to the larger system through the interconnect medium 14. In addition to the functions described above, the network engine 9 may perform all traditional functions of a network interface card.

25

It will be recognized that all the systems described above (FIGS. 1A, 2, 2A, and 2B) utilize a network engine between the external network and the other processor units that are appropriate for the function of the particular network node. The network engine may therefore offload tasks from the other processors. The network engine also may perform
30 "look ahead processing" by performing processing on a request before the request reaches whatever processor is to perform whatever processing is appropriate for the network node. In this manner, the system operations may be accelerated and resources utilized more efficiently.

ORDER SERIALIZATION

The systems described above may be implemented with order serialization techniques applied to the network processor(s) contained within the network interface engine. The order serialization techniques described herein may also be implemented in many other parallel
5 processing environments. The techniques are particularly appropriate for use with the multiple processing cores of a network processor and therefore are described for illustrative purposes with reference to a network processor. As described above and utilized herein, a network processor may include any of the wide variety of commercially available network processors, may include a network processor utilized in conjunction with another type of
10 processor, or may include a general processor configured to provide the specialized functionality equivalent, or similar, to a network processor.

FIG. 5 illustrates a simplified network processor 5000 having a plurality of processor cores 5002. For ease of illustration the network processor 5000 is shown with four processor
15 cores 5002. Each processor core may be assigned an identifier, for example a number 1, 2, 3, and 4 respectively as is shown. A input stream of workloads to be processed by the network processor 5000 is shown as data packets 5010A, 5010B, 5010C and 5010D contained within the input data stream or input data queue 5010. After processing, these data packets are provided as an output stream of processing results 5020. The output results are shown as
20 5020A, 5020B, 5020C, and 5020D which correspond to the results for each data packet 5010A, 5010B, 5010C and 5010D respectively. The output results are provided in the output data stream or output data queue 5020. In the illustration of FIG. 5, the first data packet provided to the network processor is packet 5010A and the last packet is 5010D. Similarly, the first output result from the network processor is 5020A and the last output is 5020D. As
25 shown in FIG. 5, input/output order serialization or arrival-departure order has been maintained.

The order serialization techniques described herein allow for parallel processing of the input data packets 5010A, 5010B, 5010C and 5010D by the processor cores 5002. The
30 output stream or queue 5020 may be maintained in serial order with respect to the input stream or queue 5010 even though the processing times for each data packet may be vary significantly. Thus, the benefits of parallel processing at the front end of the network processor may be obtained while still achieving an order serialized back end output. In this

manner a network processor may be now suitable for use in a network endpoint system, such as the systems of FIGS. 1A, 2 and 2A described above.

To better understand the order serialization techniques disclosed herein, the techniques will first be generally discussed with reference to the simplified network processor 5 5000 shown in FIG. 5. As each new data packet arrives at the network processor 5000, the network processor 5000 is programmed to assign the packet to a one of the processor cores 5002. The particular processor core assigned the packet is determined according to some known sequence of the processor cores. The network processor is also programmed to 10 provide the output of each processor core as the network processor output in the same sequence of processor cores. In this manner, the input/output order serialization is maintained.

An exemplary sequence of processor core assignments is a simple round robin 15 assignment technique according to the processor core identifier. For example with reference to FIG. 5, the first data packet to arrive at the network processor is assigned to processor core number 1, the second data packet to arrive at the network processor is assigned to processor core number 2, the third data packet to arrive at the network processor is assigned to processor core number 3, the fourth data packet to arrive at the network processor is assigned 20 to processor core number 4, the fifth data packet to arrive at the network processor is assigned to processor core number 1, etc. A predetermined sequence such as described above may be considered a simple static assignment sequence. The predetermined or static sequence may be established at system boot up time, during system maintenance, or at other times. The round-robin sequence for accessing the input data may be implemented with a 25 hardware latch so that input data from a network or queue is received in the desired ordered. Minimal input delivery order enforcement (on the order of a few nanoseconds or microseconds headstart in processing) may be used to allow each processor core to start somewhat in advance of another.

30 Output results provided from the network processor may then be obtained by obtaining an output result from each processor core in the same sequence that the input data packets were provided to the processor cores. Thus with respect to the example above, the network processor outputs may be provided by first obtaining a processor result from processor core number 1, then obtaining a processor result from processor core number 2,

then obtaining a processor result from processor core number 3, then obtaining a processor result from processor core number 4, then obtaining a processor result from processor core number 1, etc. In this manner, the order serialization may be maintained between the input and the output of the network processor while still utilizing the parallel processing structure of the network processor. Thus, multiple data packets of information may be communicated to a network processing system and one or more processing cores may process the data packets in a parallel processing manner that maintains order serialization even though the packets may require varying processing times. This technique allows a network processor to be suitable for use in a network endpoint system.

10

The sequence that is utilized for providing workloads to the processor cores and determine the output order of the workload results from the processor cores may be managed through the use of a processing output token. More particularly, the input sequence for the assignment of workloads to processing tasks may be a known sequence (for example the round robin sequence identified above) that may be hardware or software based. The processing output token is then utilized for providing output data from the appropriate processing core by maintaining a value within the token that corresponds to, or identifies, the processing core that should provide the next output.

20

In operation, upon one of the processing cores finishing processing, the processing core may access the processing output token to determine if the value of the token indicates that the particular processing core is valid to provide output data. Thus, if processing core number 1 has completed processing for a workload, processing core number 1 may access the processing output token to determine the value of the token. The value of the token may be a number, an address or any other means that identifies a specific processor core. If the value of the token identifies processor core number 1, then the processed information from processor core number 1 may be provided as an output of the network processor or communicated, queued, stored transferred, etc. as is appropriate for the application. The processing core number 1 may then update the processing output token to the next processor value, for example processing core number 2 in the example discussed above. In this manner, a single processing core may be operable to exclusively update the processing output token to the next processor core. As such, a single processing core may exclusively access the processing token, read the value of the processing token, output/input content if it is the valid processing core, update the processing token, and release the processing token for subsequent

30

access by other processing cores. The token may be based upon a single-writer, multiple-reader algorithm which allows only the valid processor core to modify the token.

A processor core may complete a workload prior to the proper time for the network processor to provide the output from the particular processor core. Thus, upon a processing
5 core accessing the processing output token, the value within the processing output token may not be valid for the accessing processing core. In one embodiment, the processor core may “stall” and refrain from further processing. While the processor core is stalled, the processor core may keep monitoring the processing output token until the token identifies that
10 particularly processor core.

In an alternative embodiment, the processing core may receive and/or process additional information until a valid value for the processing core is provided by the processing output token. Thus, a processor core may begin processing a second data packet
15 prior to providing the output of the first data packet to the network processor output. In this case, the processor core may have internal memory (or an assigned portion of system memory) that is utilized to store the processed data. The processor core output may be provided from this memory in a first-in-first -out (FIFO) fashion. In this manner, processing cores provide efficient utilization within a network processing system while providing
20 ordering or serialization of processed information through use of a processing output token.

Thus, through the use of a processing output token, parallel processing by the processor cores may be optimally utilized. At the input, the processor cores do not have to be latched but rather operate in a nearly continuous manner. Order enforcement is provided at
25 the final stage(s) of processing through the use of the processing output token. In this manner a network endpoint may advantageously utilize the parallel processing benefits of a network processor while still maintaining the order serialization required in endpoint processing.

It will be recognized that many other methods may be utilized to track the input /
30 output sequence to maintain order serialization and the concepts of the present invention are not limited to a particular processing output token method.

FIG. 6 illustrates one embodiment of a network processing system operable to process information using a network processor. A network processing system, illustrated generally at

100, includes a network processor 101 which may include several processing cores coupled to a network 103 through a communication port 102. The system may also include memory 105 and a processing output token 104. Processing output token 104 may include a value that corresponds to or identifies a processor core within the network processor 101 as described
5 above. Processing output token 104 may be stored within a memory location accessible by the processing cores of the network processor 101 and may include data identifying a processor core. The processor output token may also be stored as a list within a memory location within memory 105, as a variable associated with each processing core, as a hardware latch associated with a data bus or any other hardware or software configuration
10 which may be operable to provide a processing output token 104.

Memory 105 may include one or more types of memory such as random access memory (RAM), read only memory (ROM), electrically erasable programmable read only memory (EEPROM), or other types of memory operable to store information. Additionally,
15 memory 105 may be configured in many ways such as buffer memory, cache memory, FIFO memory, or other memory configurations operable to store information. Memory 105 may also include other types of information storage mediums which may include peripheral devices such as hard disk drives, tape drives, etc. or other mediums which may be located proximal or distal to system 100.

20

The network processing system 100 may be any network endpoint system or network intermediate node system. For example, the network processing system 100 may be a portion of the systems described above with reference to FIGS. 1A-1F, 2 and 2A.

25 During use, processing output token 104 may be initialized to a state that identifies the processing core within the network processor 101 that corresponds to the first processor core of the workload input sequence. Information may be received from network 103 or another processor and a processing core may process the received information. For example, a data packet of information may be received by system 100 and a process routine may be
30 deployed by a processor core within network processor 101. Such processes may include, but are not limited to, checksum computations and verification, packet replication, network header rebuilding, any other processes described above with reference to a network processor, etc.

Upon the processor core finishing the processing of the data packet, the processor core determines if the value within processing output token 104 is the same as the processor core's identifier. If the value in the processing output token corresponds to the particular core (i.e. the data is valid for the accessing processing core), the processor core outputs the processed information and updates processing output token 104 to the next processor identifier. In one embodiment, the identifier stored within the processing output token 104 may not be valid for the processing core accessing the processing output token 104. As such, the invalid processing core may stall or may continue to process additional information or data packets until the identifier of the processing output token 104 is valid for the processing core. As such, System 100 allows for an ordered serialization of information through the use of a processing output token 104 that has a processing order or sequence which may be updated by a valid processor core within network processor 101. The system thereby increases processing efficiency and provides efficient processing of network communicated information even if the processing times for individual packets varies significantly.

15

FIG. 7 illustrates one embodiment of a method for a processing system using a simple static processing sequence, such as a round robin sequence. The simple static sequence may be implemented through an algorithm contained in logic, a state machine, etc. The method begins at step 2000. At step 2010, a processor, such as a processing core within a network processor, accesses an input data queue and dequeues and processes information, data packets, etc., described collectively as data units. The processor cores may access the input queue according to the established static processing sequence. For example, the processor cores may access the input queue in a round robin fashion such as described above. Upon processing a data unit, the method proceeds to step 2020 where the processor core "latches" a data memory bus or data line and reads the processor core identifier associated with the processing output token.

Upon reading the identifier within the processing output token, the method proceeds to step 2030 where the method determines if the valid processor core identified within the token is the processor core accessing the processing output token. If the processor core reading the token is not the identified processor core, the method proceeds to step 2040 where the method releases the token (i.e. "de-latch" the database) and proceeds to step 2010 where the processing core accesses/dequeues/processes additional data unit(s) or to step 2020 where the method again reads the identifier in the processing output token (a stall).

If at step 2030, the processor core identified within the token is the same as the processor core accessing the token, the method proceeds to step 2050 where the method outputs the data unit(s) processed by the processor core. The data unit(s) may then be placed
5 within an output queue or queues. The method then proceeds to step 2060 where the method updates the processor core identifier within the token to the next appropriate processor core identifier and to step 2070 where the method releases the processing output token. Upon releasing the token, the method proceeds to step 2010 where the method again accesses the input queue and dequeues and processes data unit(s) using the processor core.

10

The processor cores may access the input queue according to processing sequences different from the round robin sequence described above. For example another static processing sequence may be based upon a user or system defined sequence list. The sequence list may be provided at system boot up time, during system maintenance or at other
15 times. In this case, the data within the processing output token corresponds to the defined sequence list. The processing output token may be realized as a fixed list located within a memory location accessible by a processing core. The processing output token may include multiple fields containing the data of the list. Each field may contain the identifier for a particular processor core. In addition, a mechanism may also be provided to indicate which
20 particular field is the current valid field that contains the identifier for the current valid processor core. This mechanism may be a pointer, an index system, etc. For illustrative purposes, a pointer will be described, however, the use of a list is not limited to any particular method of indicating the valid field. Upon determining that a processing core is valid, the processor core may output data and update the index / pointer accordingly.

25

FIG. 8 illustrates one embodiment of a processing output token for use with a static processing sequence based upon a user defined sequence list. This type of sequence may be considered a static list sequence. The processing output token, illustrated generally at 400 may be realized as a fixed list located within a memory location accessible by the processor
30 cores. Processing token 400 generally illustrates a list of processor core identifiers (in this case core numbers) associated with a plurality of processing cores for a network processor. Array 401 includes a first field 402, a second identifier field 403, a third field 404, a fourth field 405, a fifth field 406 a, and sixth field 407. The number of fields shown is provided for illustrative purposes and more or less fields may be utilized. As shown in FIG. 8, the

processor core identifiers contained in the fields 402, 403, 404, 405, 406 and 407 contain processor core numbers 1, 3, 2, 4, 5, and 6 respectively. The sequence of the cores as shown in FIG. 8 is merely illustrative and many other sequences may be provided in the list.

5 During use, a processing core may finish processing information and access processing output token 400 to determine a valid processor core for outputting or queuing information to / from the network processor. To identify the current valid processor core, the processing token includes a pointer 408 that may point to one of the fields in the memory. As mentioned above, an index or any other mechanism may also be used to select the valid field.

10 A latch may be placed on processing output token 400 (for example on the pointer 408) and, upon determining a valid processor core, the valid processor core may output the information or data unit(s). Upon outputting the information on data unit(s), the processing output token 400 may be updated by the processor core updating the pointer 408. The network processing core may then release processing token 400 by releasing the pointer 408 to allow other

15 network processing cores to access processing token 400. As used herein the term latch may be construed as any mechanism which prevents other processor cores from changing the processing output token while one core is utilizing the token. For example, the token update operation can be done atomically in a memory location (e.g. a memory field that can be updated in a single write cycle). In this case the "latch" may actually be a null operation.

20 This scenario requires no special "latching" operation or hardware.

In the pointer example, the processing output token 400 may be updated by incrementing the pointer 408 so that the pointer 408 points to the next field. Thus for the example shown in FIG. 8, when the pointer 408 points to the field 402 the valid processor

25 core for outputting data is processor core number 1. After processor core number 1 outputs data, the pointer is moved to the field 403 which identifies processor core number 3 as valid for outputting data. In this fashion the pointer may be incremented by each valid processor core until processor core 6 outputs valid data. The pointer may be configured so that after the pointer has reached the bottom of the list the pointer wraps around to the top of the list. Thus

30 in the example, processor core number 6 will increment the pointer which returns the pointer 408 back to the position of pointing to field 402.

As in the embodiments discussed above, a network processing core may finish processing information prior to the processor core being a valid processor core for

outputting/queuing information. As such, the processor core may stall awaiting it to become valid or the processor core may queue and process additional information until a valid processing value is provided by processing token 400.

5 FIGURE 9 illustrates a method for processing information via a network processing system using a user or system defined static list sequence such as described above. The method begins at step 500. The method proceeds to step 501 where a processing core associated with a network processor accesses an input buffer or queue, dequeues information or data unit(s), and processes data unit(s) using the processing core. The method then
10 proceeds to step 502 where the processing core latches the processing output token by latching the pointer and determines which field is then valid, i.e., which field is currently being pointed to. The processor core may latch the processing output token to provide exclusive access to read and modify the output token. The processor core may then read which field that the pointer is pointing to (or read which field the index is then selecting if an
15 index is used). The method then proceeds to step 503 where the processor core identified in the pointed to field is read. Using the list of FIG. 8 as an example, if the pointer points to the processor core identifier field 406, the processor core number 6 will be the valid processor core read in step 503. Upon determining the valid processor core, the method proceeds to step 504 where the method determines if the processor core identifier matches that of the
20 processing core currently accessing the processor output token. If the identifiers do not match, the method proceeds to step 505 where the processing core releases the token and then to step 501 where the method may access the input queue/dequeue/process data unit(s) or to step 502 where the method latches the processor output token and reads the valid field again. When utilizes a pointer or index it will be recognized that only the token pointer field or
25 index field needs to be latched or atomically modified.

If at step 504 the processor core identifier matches the identifier of the processor core accessing the processing output token, the method proceeds to step 506 where the method outputs the processed data units to an output queue and to step 507 where the token is
30 updated (i.e. the token pointer or index is incremented) to the next field in the list. The method then proceeds to step 508 where the processing output token is released and to step 501 where the processor core may access the input queue(s), dequeue, and process data unit(s) again. As such, an ordered serialization of data may be maintained using a processing output token thereby providing efficient use of a network processor.

In another embodiment, a processing output token may be implemented as a dynamic processing output token that expands and compresses based upon the number of processors or processor cores processing information. In this example, the sequence that processor cores are assigned an input workload is not static or predetermined but rather dynamic. In the dynamic input processing sequence each processing core may accept or “grab” a workload when the processing core has the resources to accept additional workloads. Order enforcement hardware at the input for assignment workloads to processor cores is therefore not necessary. The processing output token in this case is configured as a logical or literal queue that may expand and contract.

When the first workload is accepted by a processor core, the identity of the processor core is placed in an element or field that is enqueued to the token queue which acts as a FIFO queue. For each successive workload, the identity of the processor core that accepted the workload is placed in a field that is similarly enqueued to the token queue. In this manner the order that the processor cores accept workloads may be tracked, with the processor core identity associated with the most recent workload accepted being enqueued in a field at the bottom of the queue and the processor core identity associated with the oldest workload accepted being enqueued in a field at the head or top of the queue.

With this dynamic approach, the processor core that is valid to provide an output is identified at the head or top of the queue. Thus, if a processor core is ready to provide an output result, the processor core may compare its identity to the identity contained at the head of the queue. After the processor core that is valid has delivered its processed data, the processor core may update the processing output token by removing (i.e. dequeuing its identity from the head or top of the queue.

FIG. 10 illustrates one embodiment of a method for processing information via a network processing environment using a dynamic processing output token. The method begins at step 700. At step 701, a processing core accesses a data input queue(s) and dequeues information or data unit(s). The method proceeds to step 702 where the method latches on output token queue and enqueues or adds the processor core identity to the field at the bottom of the processing output token queue. The method then proceeds to step 703 where the processing output token is released. The method then proceeds to step 704 where

the method processes data unit(s) using the processor core. Upon completing processing the data unit(s), the method proceeds to step 705 where the method latches and accesses the processing output token queue and reads the queue head field (or element) to obtain a processor identity. The method then proceeds to step 706 where the method determines if the
5 processor identity within the queue head element corresponds to the processor core accessing the processing output token.

If the processor core identity in the token queue head element does not correspond to the inquiring processing core, the method proceeds to step 707 where the method releases the
10 token and then returns to either step 701 where the processing core accesses/dequeues/processes data unit(s) or stalls by returning to step 705 where the output token queue head element is read again.

If at step 706 the processor core identity in the queue head element corresponds to the
15 inquiring processing core, the method proceeds to step 708 where the processor core outputs the data unit(s). The method then proceeds to step 709 where the processing core dequeues the current queue head element from the processing output token and to step 710 where the method releases the token. The method then proceeds to step 701 where the processing core may access the input queue, dequeue and process additional data unit(s).

20

The methods described above have included steps described in terms including latching and releasing the processing output token. Generally such steps are utilized to block manipulation of the processing output token or put a "lock" on the token when one core is accessing the token. Such steps may be implemented with a wide range of hardware and/or
25 software techniques. For example, as used herein the term latch may be construed as any mechanism which prevents other processor cores from changing the processing output token while one core is utilizing the token. For example, the token update operation can be done atomically in a memory location (e.g. a memory field that can be updated in a single write cycle). In this case the "latch" may actually be a null operation. This scenario requires no
30 special "latching" operation or hardware. Thus if a system is configured such that access to the processing output token by two processor cores will not overlap, the latch and release steps may even be omitted.

The methods described above have been shown and discussed with respect to one processor core. It will be recognized, however, that each processor core may implement these methods in parallel. In this manner, a processor core may access a processing token in a substantially isolated manner thereby allowing a valid processing core to automatically
5 update the processing token for all of the processing cores associated with a network processor while parallel processing is still enabled.

The above examples have also been described with reference to a network processor having multiple processing cores. It will be recognized that the principles disclosed herein
10 may also be applied to separate processors operating in parallel. In such a case, the techniques described above are applicable if one assumes each processor core may be a separate processor.

Examples described above have provided with reference to a network processor
15 containing a single data input queue and a single data output queue, for example the data input queue 5010 and data output queue 5020 of FIG. 5. It will be recognized that the techniques described herein may be equally applied to processor systems that have more than one data input queue and/or more than one data output queue. FIG. 11 illustrates a network processor 5000 having multiple cores. As shown in FIG. 11A, three data input queues 5010
20 may be provided and one data output queue 5020 is provided. The queues 5010 and 5020 may be implemented in memory within the network processor 5000. In one exemplary use, each data input queue 5010 is provided as a separate queue for data received from a separate network source. Utilizing the processing token techniques described above, order serialization may be maintained between the input order that the processor cores access data
25 from the input queues 5010 and the output order that the processor cores provide the data to the output queue 5020. Thus, no matter which input queue that data is obtained or "grabbed" from by a processor core, the processor core results will be provided at the output in the same sequence that the data was obtained or "grabbed."

30 FIG. 11B illustrates another embodiment of multiple input and output queues. FIG. 11B is similar to FIG. 11A except in this system a single data input queue 5010 is provided and multiple data output queues 5020 are provided. An exemplary use of such a system may be an application in which the incoming data includes some indicator or tag which the processor will recognize as being affiliated specifically with one of the output queues. The

processing results for the data will then be directed to the appropriate output queue affiliated with the data. Order serialization between the input and the output of the system of FIG. 11B may be obtained by utilizing the processing output token techniques described above. The dynamic list or queue serialization technique described above may be particularly useful for systems such as shown in FIG. 11B. It will be recognized that many other arrangements of multiple input and/or output queues may be utilized in addition to the examples shown herein.

The examples described above have been made with reference to a single network processor that has multiple processor cores. Such a system may be considered to be a "tightly bound" or highly embedded system. In the tightly bound system a discrete number of processor cores are generally located on a single integrated circuit and are architecturally tightly connected to each other through on-chip data buses that provide internal communication paths between the processing cores and/or shared memory.

15

The techniques described above may also be implemented with "less than tightly bound" systems. Such systems may include multiple processors, with the processors operating in a symmetrical or asymmetrical multi-processing fashion. The individual processors may be relatively tightly coupled by a system bus and may share common memory. The processing output token in these systems may include processor identities for each of the processors. Thus, a single processing output token may be utilized for multiple processors.

The order serialization techniques provided herein may also be utilized in a "loosely-bound" processing environment which may include one or more separate network systems. In a loosely-bound processing environment one or more systems may have a network processor. The systems may communicate with each other via a network or switch and may require some messaging or state mechanisms for one system to access information from another. In such a system, each network processor may include several processing cores that may utilize a common processing output token. The processing output token may be stored proximal to each system within an atomically updated memory location accessible by each system. As such, each processing core associated with each system may access the processing output token to determine a valid processor core. Upon determining a valid processor core, the processor core may update the processing output token.

30

FIG. 12 illustrates a "loosely coupled" distributive processing network for processing information that may utilize the order serialization techniques described herein. The distributed processing network, illustrated generally at 600, includes a processing Node A 601, a processing Node B 602, processing Node C 603, or other processing Nodes *N* 604 5 communicatively coupled via a network 605. In one embodiment, one or more processing Nodes may include a network processor having a plurality of processing cores operable to process information communicated via network 605. Alternatively, each node may contain a processing unit other than a network processor. A common token 610 may be provided or 10 alternatively tokens 612 may be provided at each node. The tokens 612 may be stored in memory locations that are accessible by each node. In yet another alternative, one token 612 may be provided to act as common token 610 which can be passed from node to node, or be granted to the requesting node(s) by a "token sequence" (which could be one of the designated nodes).

15

The techniques described above for order serialization may be implemented in the distributive processing network through the use of tokens 610 or 612. As such, upon a network processor or processing core within a node completing processing, the associated processing core may access the commonly accessible memory location to determine if a valid 20 processor identifier for that processing core is within the processing token.

If multiple tokens 612 are utilized, one token may be provided the initial identifier value, initial static token list or initial dynamic token list. After output data is provided, the token may be released and the token data may be either passed on to token memory location 25 of the next node in the processing sequence or the token data may be made available so that the next node may grab the data and place it in the next nodes token memory location. The token values could include a node network address and a processor ID pair, or just a node network address, or some other value.

30 It will be understood with benefit of this disclosure that although specific exemplary embodiments of hardware and software have been described herein, other combinations of hardware and/or software may be employed to achieve one or more features of the disclosed systems and methods. Furthermore, it will be understood that operating environment and application code may be modified as necessary to implement one or more aspects of the

disclosed technology, and that the disclosed systems and methods may be implemented using other hardware models as well as in environments where the application and operating system code may be controlled.

WHAT IS CLAIMED IS:

1. A network processing system comprising:
a network processor having a plurality of processing cores, the processing cores
operable to process information in a substantially parallel manner; and
5 a processor value associated with each of the processing cores, the processor value
operable to identify each processing core for communicating the information.
2. The system of Claim 1, further comprising a processing token operably coupled to the
network processor, the processing token including a valid processor value associated with
10 one of the processing cores.
3. The system of Claim 2, wherein the processing token comprises a hardware latch
deployable by the processing cores.
- 15 4. The system of Claim 2, wherein the processing token may be updated by a processing
core associated with the valid processor value.
5. The system of Claim 2, wherein the processing token may be exclusively accessed by
a processing core within the network processor.
- 20 6. The system of Claim 2, wherein the processing token maintains a processing order
associated with processing information using the network processor.
7. The system of Claim 2, further comprising memory operably coupled to the network
25 processor, the memory operable to store the processor values associated with each of the
processing cores.
8. The system of Claim 7, wherein the memory comprises the processing token.
- 30 9. The system of Claim 7, wherein the memory comprises a list of the processor values,
the list having a reference identifying the valid processor value.

10. The system of Claim 1, further comprising plural network processors operably coupled to the network processor.
11. The system of Claim 10, wherein the plural network processors comprise distributed
5 network processors.
12. The system of Claim 1, wherein the processing cores comprise processes operably associated with the network processor.
- 10 13. A method for processing information in a network environment comprising:
processing information using a network processor having a plurality of processing
cores;
determining a valid processor value operably associated with communicating the
information; and
15 communicating the processed information from the network processor in response to
determining the valid processor value.
14. The method of Claim 13, wherein the processing further comprises:
accessing a processing input queue including data packets; and
20 dequeuing at least one data packet from the processing input queue.
15. The method of Claim 13, further comprising accessing a processing token associated with providing the valid processor value.
- 25 16. The method of Claim 15, further comprising latching the processing token to
determine the valid processing value.
17. The method of Claim 16, further comprising releasing the processing token upon
determining the valid processor value.
- 30 18. The method of Claim 16, further comprising:
updating the processing token to a next processor value; and
releasing the processing token.

19. The method of Claim 18, further comprising:
queuing the information within an output queue; and
communicating the information from the output queue to a communication medium.
- 5
20. The method of Claim 18, further comprising:
dequeueing the information from an input queue; and
processing the information using the processing core.
- 10 21. A parallel network processing system comprising:
a plurality of processing cores operable to process information in a substantially
parallel manner;
a processor value associated with each of the processing cores, the processor value
identifying each processing core;
15 a processing token operably associated with the processing cores, the processing
token operable to identify a processing core to communicate information;
wherein the processing token is operable to be updated by a valid processing core; and
output memory coupled to the plurality of processing cores, the output memory
operable to store the information based on the valid processing core.
- 20
22. A method of operating a network processor comprising
providing a plurality of processor cores within the network processor;
receiving multiple incoming data packets within the network processor;
performing parallel processing on at least a portion of the data packets with the
25 multiple processor cores, the processing times for a plurality of the incoming
data packets varying;
providing processor core processing output results which are to be forwarded for
additional processing; and
maintaining order serialization of the processor core output results with respect to the
30 order of the multiple incoming data packets,
wherein the order serialization is maintained even though the processing times vary.
23. The method of claim 22, the maintaining step comprising determining if an individual
processor core is a currently valid processor core.

24. The method of claim 23, further comprising stalling the processing of one of the processor cores if the processor core is not a currently valid processor core.
- 5 25. The method of claim 23, further comprising processing additional data in one of the processor cores if the processor core is not a currently valid processor core.
26. The method of claim 22, wherein the order serialization is performed by accessing a processor output token.
- 10 27. The method of claim 26, further comprising inhibiting changes by one processor core to the processor output token when another one processor core is accessing the processor output token.
- 15 28. The method of claim 27, further comprising latching the processor output token to achieve the inhibiting.
29. The method of claim 27, further comprising utilizing a currently valid processor core to update the processor output token.
- 20 30. The method of claim 26, further comprising utilizing a currently valid processor core to update the processor output token.
31. The method of claim 30, wherein a static sequence is utilized to order serialize the
25 output results.
32. The method of claim 30, wherein a dynamic sequence is utilized to order serialize the output results.
- 30 33. The method of claim 22, wherein a static sequence is utilized to order serialize the output results.
34. The method of claim 33, wherein the static sequence is a logical based sequence.

35. The method of claim 34, wherein the static sequence is a round robin sequence.
36. The method of claim 34, wherein the sequence is a defined list sequence.
- 5 37. The method of claim 22, wherein a dynamic output sequence is utilized to order serialize the output results.
38. A method of operating a network endpoint system, comprising:
providing a processor engine, the processor engine comprising a plurality of processor
10 cores;
receiving an incoming data stream from a network connection;
assigning portions of the incoming data stream to the plurality of processor cores for
processing;
processing the portions of the incoming data stream within the processor cores to
15 provide output data which is to further processed by other resources of the
network endpoint system; and
providing the output data from the processor cores in an order serialized manner
which corresponds order of the incoming data streams.
- 20 39. The method of claim 38, the providing step comprising determining if an individual processor core is a currently valid processor core.
40. The method of claim 39, further comprising stalling the processing of one of the processor cores if the processor core is not a currently valid processor core.
- 25 41. The method of claim 39, further comprising processing additional data in one of the processor cores if the processor core is not a currently valid processor core.
42. The method of claim 38, wherein the order serialization is performed by accessing a
30 processor output token.
43. The method of claim 42, further comprising inhibiting changes by one processor core to the processor output token when another one processor core is accessing the processor output token.

44. The method of claim 43, further comprising latching the processor output token to achieve the inhibiting.
- 5 45. The method of claim 43, further comprising utilizing a currently valid processor core to update the processor output token.
46. The method of claim 42, further comprising utilizing a currently valid processor core to update the processor output token.
- 10 47. The method of claim 42, wherein processing times for the plurality of processor cores to process the data packets varies.
48. The method of claim 42, wherein a static sequence is utilized to order serialize the
15 output results.
49. The method of claim 48, wherein the static sequence is a logical based sequence.
50. The method of claim 49, wherein the static sequence is a round robin sequence.
- 20 51. The method of claim 49, wherein the sequence is a defined list sequence.
52. The method of claim 42, wherein a dynamic sequence is utilized to order serialize the output results.
- 25 53. The method of claim 38, wherein a static output sequence is utilized to order serialize the output results.
54. The method of claim 38, wherein a dynamic output sequence is utilized to order
30 serialize the output results.
55. A method of operating a network processor comprising:

receiving input data by the network processor in the form of a plurality of data
packets to be processed at least in part by the network processor, the network
processor providing output data to be subject to additional processing;
assigning the data packets to multiple processor cores within the network processor so
5 that parallel processing of the data packets may be performed;
processing the data packets at least in part with the processor cores;
determining if output results of an individual processor core may be provided for
further processing, the determining being based upon an output sequence; and
providing the output results of the individual processor core based upon the
10 determining step,
wherein the output results of a plurality of the processor cores are provided in an
output order corresponding to the order of the input data.

56. The method of claim 55, the determining step comprising determining if the
15 individual processor core is a currently valid processor core.

57. The method of claim 56, further comprising stalling the processing of one of the
processor cores if the processor core is not a currently valid processor core.

20 58. The method of claim 56, further comprising processing additional data in one of the
processor cores if the processor core is not a currently valid processor core.

59. The method of claim 55 wherein the ordering is performed by accessing a processor
output token.

25 60. The method of claim 59, further comprising inhibiting changes by one processor core
to the processor output token when another one processor core is accessing the processor
output token.

30 61. The method of claim 60, further comprising latching the processor output token to
achieve the inhibiting.

62. The method of claim 60, further comprising utilizing a currently valid processor core
to update the processor output token.

63. The method of claim 59, further comprising utilizing a currently valid processor core to update the processor output token.
- 5 64. A method of operating a network processor comprising:
receiving incoming data packets in an incoming data order;
processing incoming data packets in a parallel processing manner with a plurality of
processor cores within the network processor;
generating processing results with the processor cores, the processor results for a
10 plurality of the incoming data packets being generated in a time order that
varies from the incoming data order; and
order serializing the output results provided from the plurality of processor cores, the
order serialization being with respect to the incoming data order; and
forwarded the output results so that additional processing may be performed upon the
15 output results.
65. The method of claim 64, wherein the processing times for the plurality of processor cores to process the data packets varies.
- 20 66. The method of claim 64, wherein a static sequence is utilized to order serialize the output results.
67. The method of claim 66, wherein the static sequence is a logical based sequence.
- 25 68. The method of claim 67, wherein the static sequence is a round robin sequence.
69. The method of claim 66, wherein the sequence is a defined list sequence.
70. The method of claim 64, wherein a dynamic sequence is utilized to order serialize the
30 output results.
71. A method of configuring an endpoint system, comprising:
providing a network interface processing engine to receive an incoming data stream
from a network;

providing a plurality of processor cores with the network interface processing engine;
providing at least one system processing engine to perform endpoint functions in
response to the incoming data stream;
providing an interconnection coupling the network interface processing engine and
5 the at least one system processing engine;
processing the incoming data stream with the plurality of processor cores in a parallel
manner;
generating processor results from the incoming data stream in the plurality of
processor cores in a time sequence that does not correspond to an input
10 sequence of the incoming data stream; and
ordering an output sequence of the processor results from the plurality of processor
cores such that a network interface processing engine output data stream is
order serialized with respect to the input sequence of the incoming data
stream.

15

72. The method of claim 71, wherein the processing times for the plurality of processor
cores to process the data packets varies.

20

73. The method of claim 71 wherein the output sequence is a static sequence.

74. The method of claim 73, wherein the static sequence is a logical based sequence.

75. The method of claim 74, wherein the static sequence is a round robin sequence.

25

76. The method of claim 73, wherein the sequence is a defined list sequence.

77. The method of claim 71, wherein the sequence is a dynamic sequence.

30

78. The method of claim 71 wherein the ordering is performed by accessing a processor
output token.

79. The method of claim 71, the ordering step further comprising determining, when
processing results are available from one of the processor cores, if that processor core is a
currently valid processor core.

80. The method of claim 79, further comprising stalling the processing of one of the processor cores if the processor core is not a currently valid processor core.
- 5 81. The method of claim 79, further comprising processing additional data in one of the processor cores if the processor core is not a currently valid processor core.
82. A network processor, comprising:
an input, the input provided to receive an input data stream;
10 a plurality of processor cores, the processor cores be configured to process data packets and then forward the data packets for additional processing, the processor cores coupled to the input; and
a processor output token coupled to the plurality of processor cores so that the plurality of processor cores utilize the processor output token to determine an
15 output sequence for the processor cores,
wherein the output sequence of the processor cores is order serialized with respect to the input data stream.
83. The network processor of claim 82, wherein the processing times for the plurality of
20 processor cores to process the data packets varies.
84. The network processor of claim 82 wherein the output sequence is a static sequence.
85. The network processor of claim 84, wherein the static sequence is a logical based
25 sequence.
86. The network processor of claim 85, wherein the static sequence is a round robin sequence.
- 30 87. The network processor of claim 84, wherein the sequence is a defined list sequence.
88. The network processor of claim 87, wherein the processor output token comprises memory fields containing processor core identifiers.

89. The network processor of claim 88, wherein the processor output token further comprises a field identifier.
90. The network processor of claim 89, wherein the field identifier is a pointer.
- 5 91. The network processor of claim 89, wherein the field identifier is an index.
92. The network processor of claim 82, wherein the sequence is a dynamic sequence.
- 10 93. The network processor of claim 92, wherein the processor output token comprises a queue containing processor core identifiers.
94. The network processor of claim 93, wherein the queue size may vary.
- 15 95. A network connectable computing system, the system being configured to be connected on at least one end to a network, the system comprising:
a network interface engine comprising at least one network processor having a plurality of processor cores, the network interface engine coupling an input data stream from the network to the computing system;
20 at least one system processor engine providing system functionality processing; and a distributed interconnection between the at least one system processor engine and the network interface engine,
wherein processor results from the plurality of processor cores are provided in a time sequence that is different from an input sequence of the incoming data stream;
25 and order serialization is applied within the network interface engine such that a network interface processing engine output data stream is order serialized with respect to the input sequence of the incoming data stream.
96. The system of claim 95, wherein the network processor analyzes headers of the data
30 packets provided to the computing system.
97. The system of claim 95, wherein the system is an intermediate network node system.
98. The system of claim 97, wherein the system is a network switch.

99. The system of claim 95, wherein the system is a network endpoint system.
100. The system of claim 95, wherein the system is a network endpoint system having at
5 least one server or at least one server card.
101. The system of claim 95, wherein the system is incorporated into a network interface card.
- 10 102. The system of claim 100, wherein the system is a content delivery system.
103. The system of claim 102, wherein the distributed interconnection is a switch fabric.
104. The system of claim 95, wherein system is an asymmetric multi-processing system
15 having a plurality of system processor engines.
105. The system of claim 95, wherein the plurality of system processor engines are configured to perform separate tasks.
- 20 106. The system of claim 105, wherein the distributed interconnection is a switch fabric and the task specific processor engines include storage or application processor engines.
107. The system of claim 106, wherein the task specific processor engines include storage and application processors.

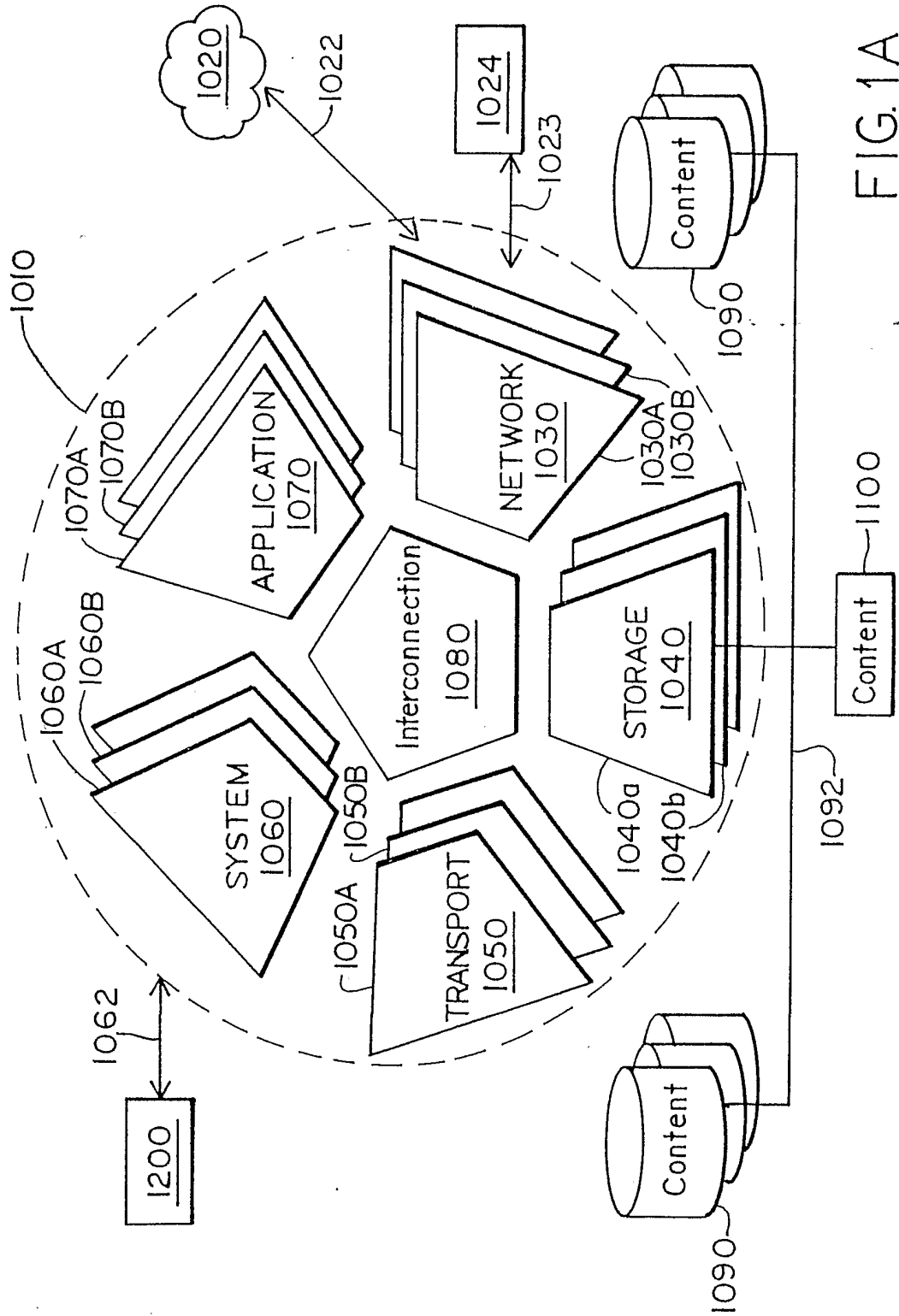

FIG. 1A

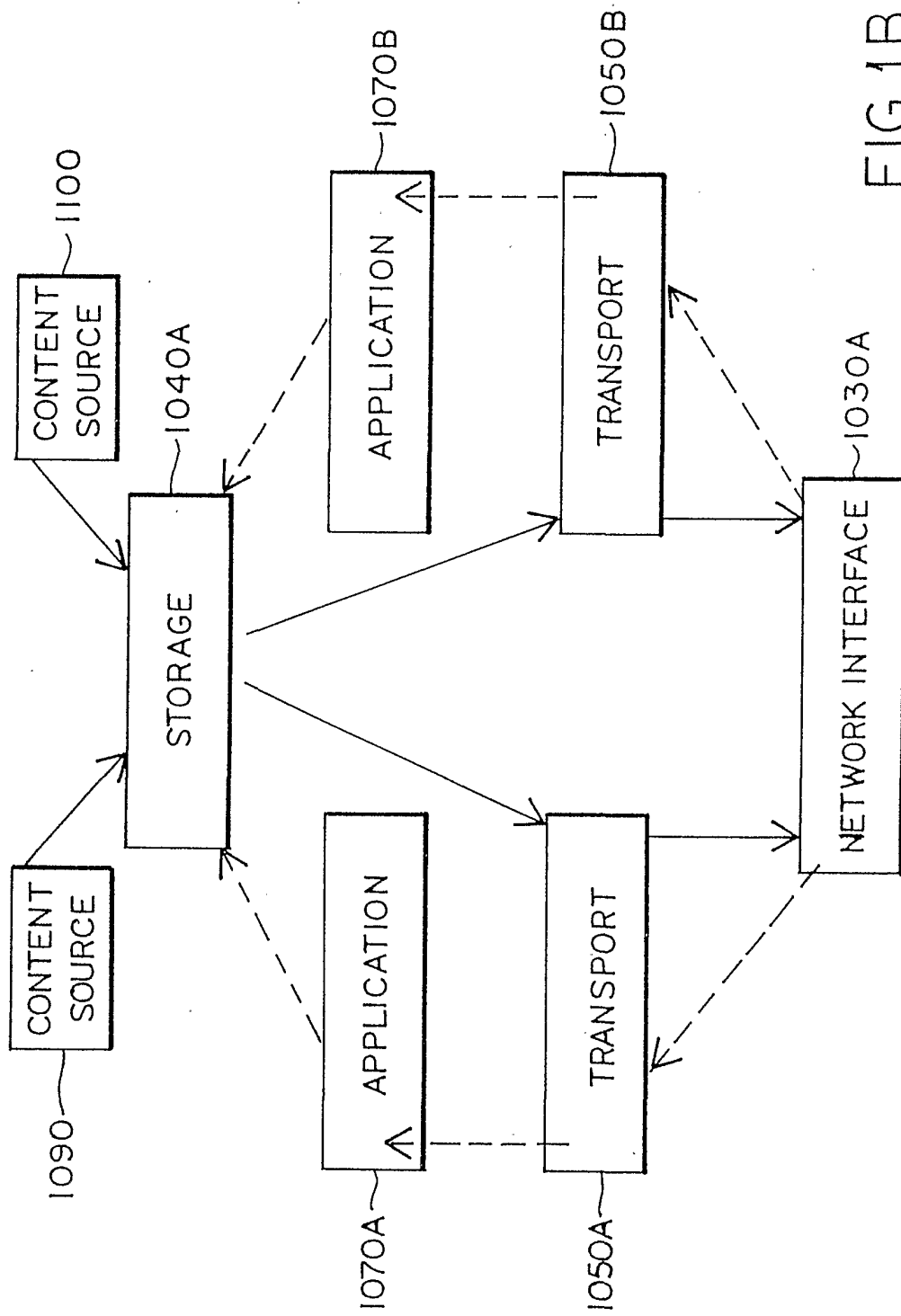

FIG. 1B

FIG. 1C FIG. 1C^I FIG. 1C^{II}

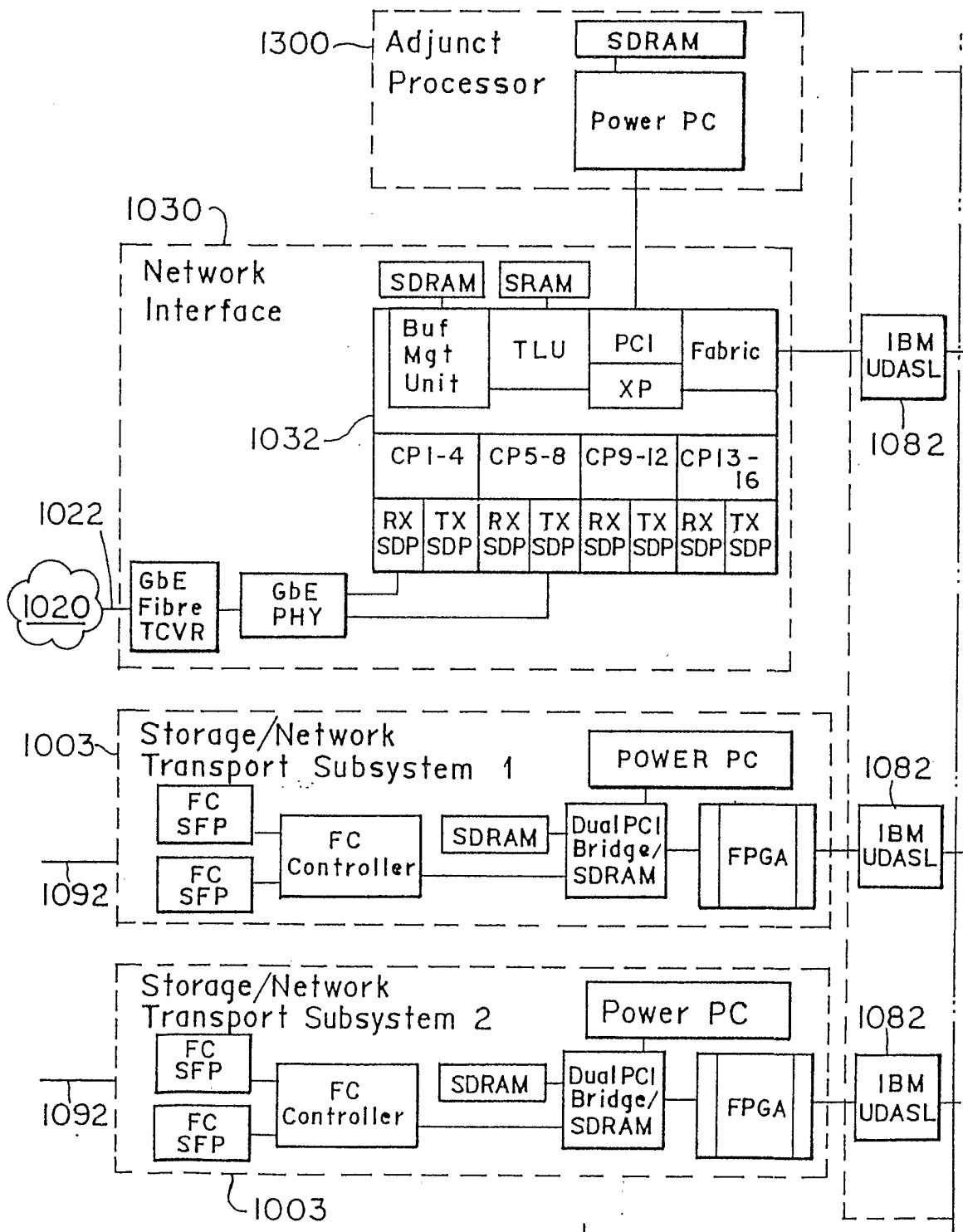

FIG. 1C^I

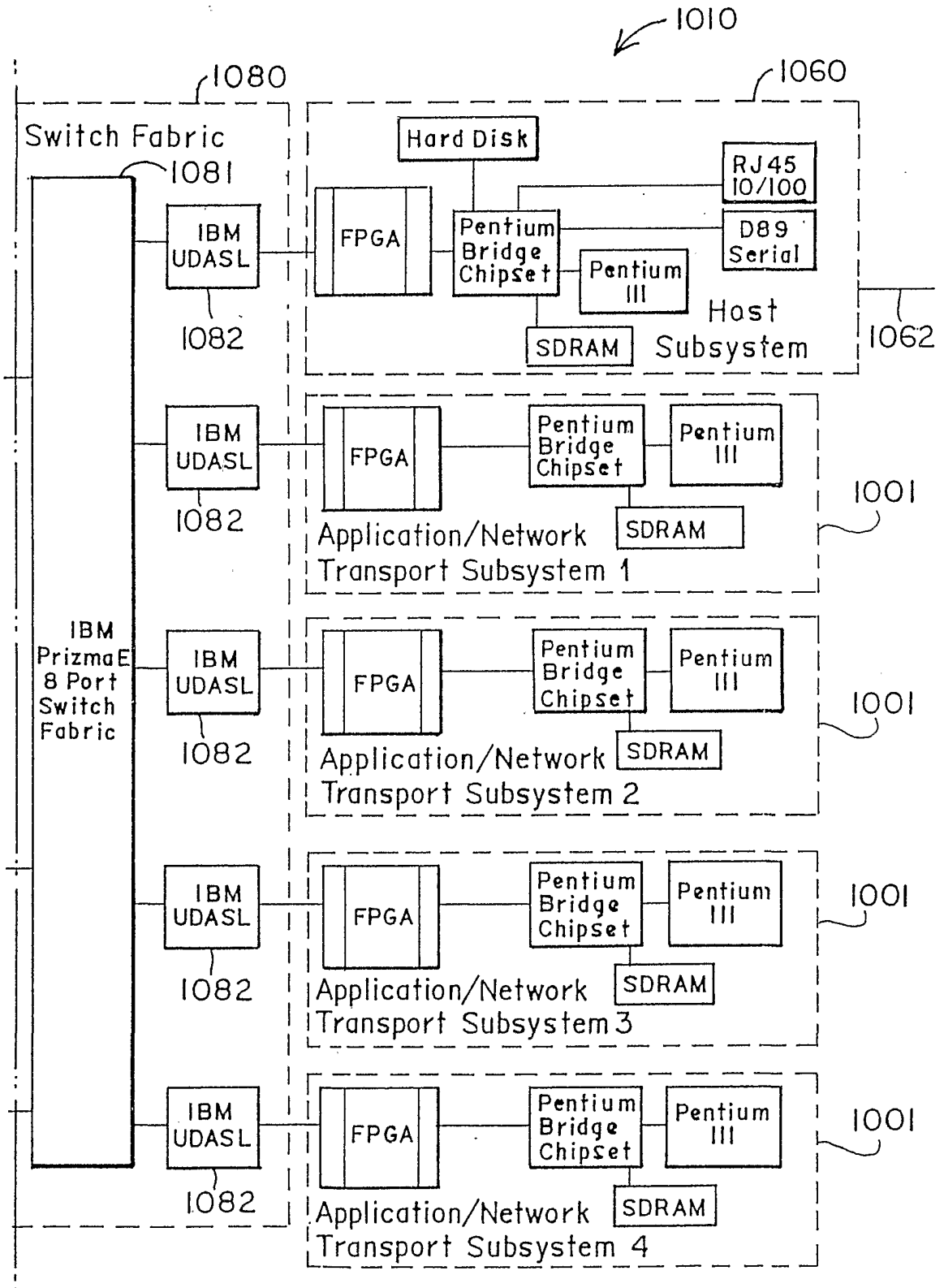
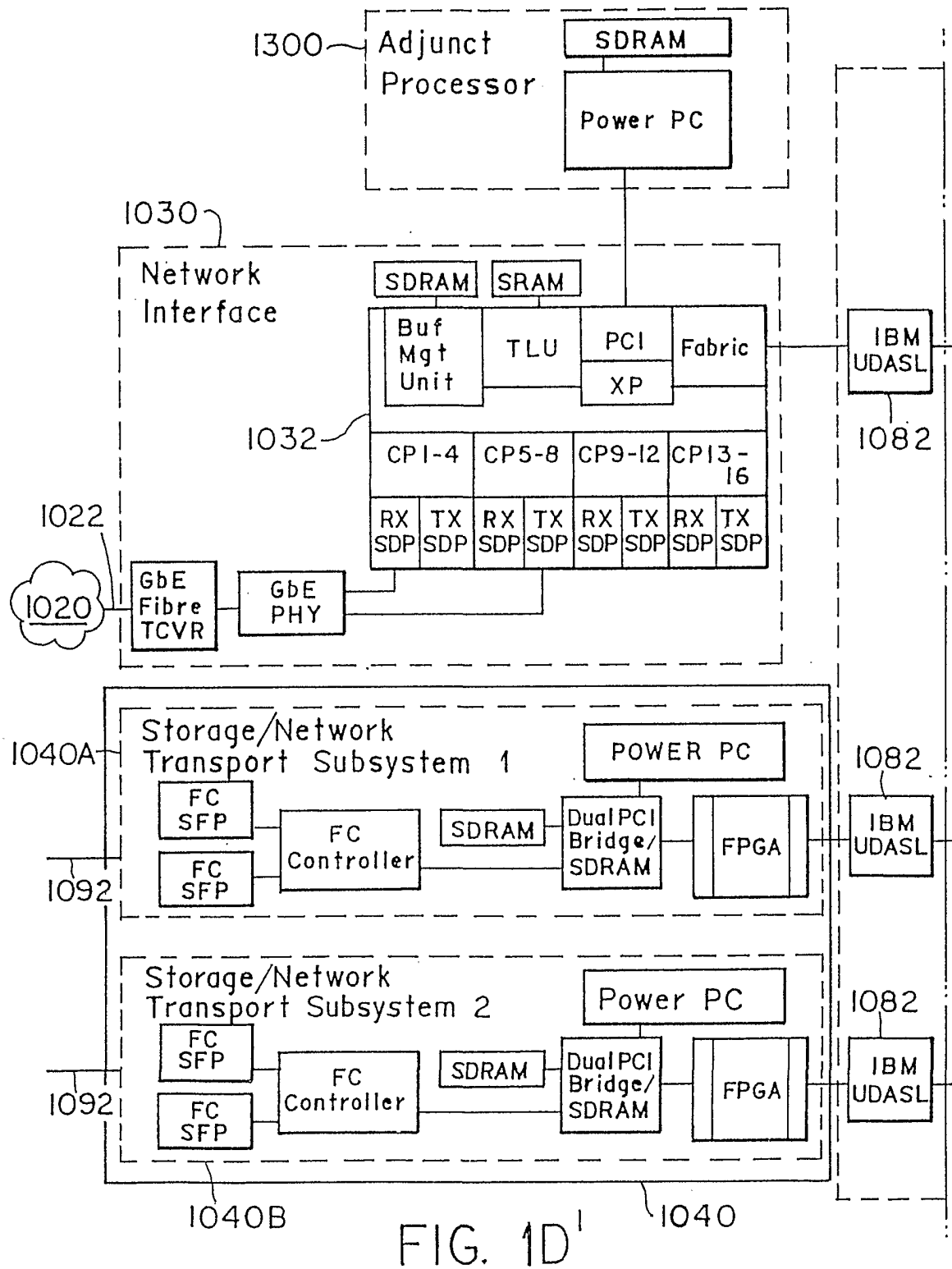

FIG. 10''

FIG. ID FIG. ID^I FIG. ID^{II}



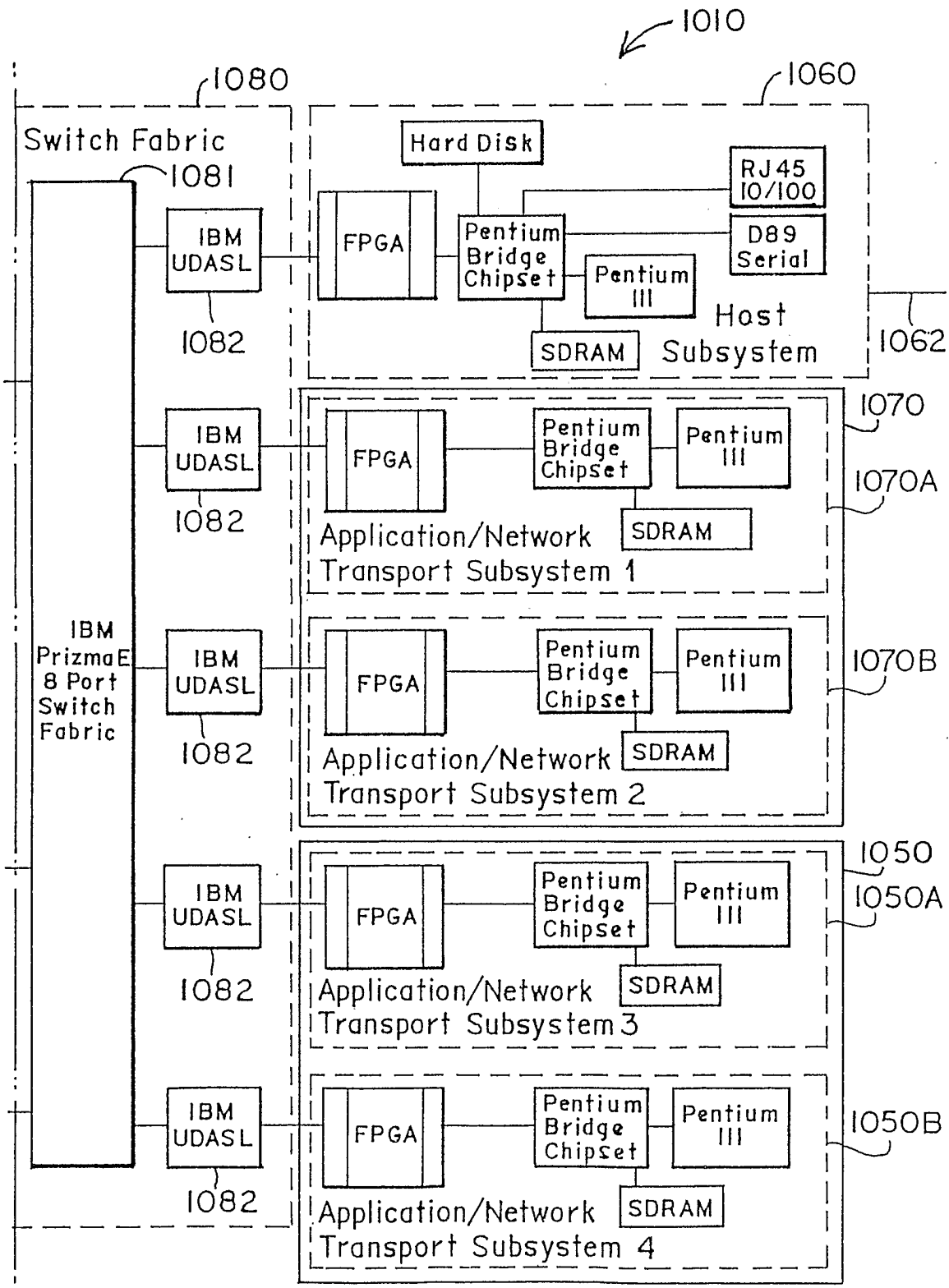

FIG. 1D''

FIG. 1E FIG. 1E^I FIG. 1E^{II}

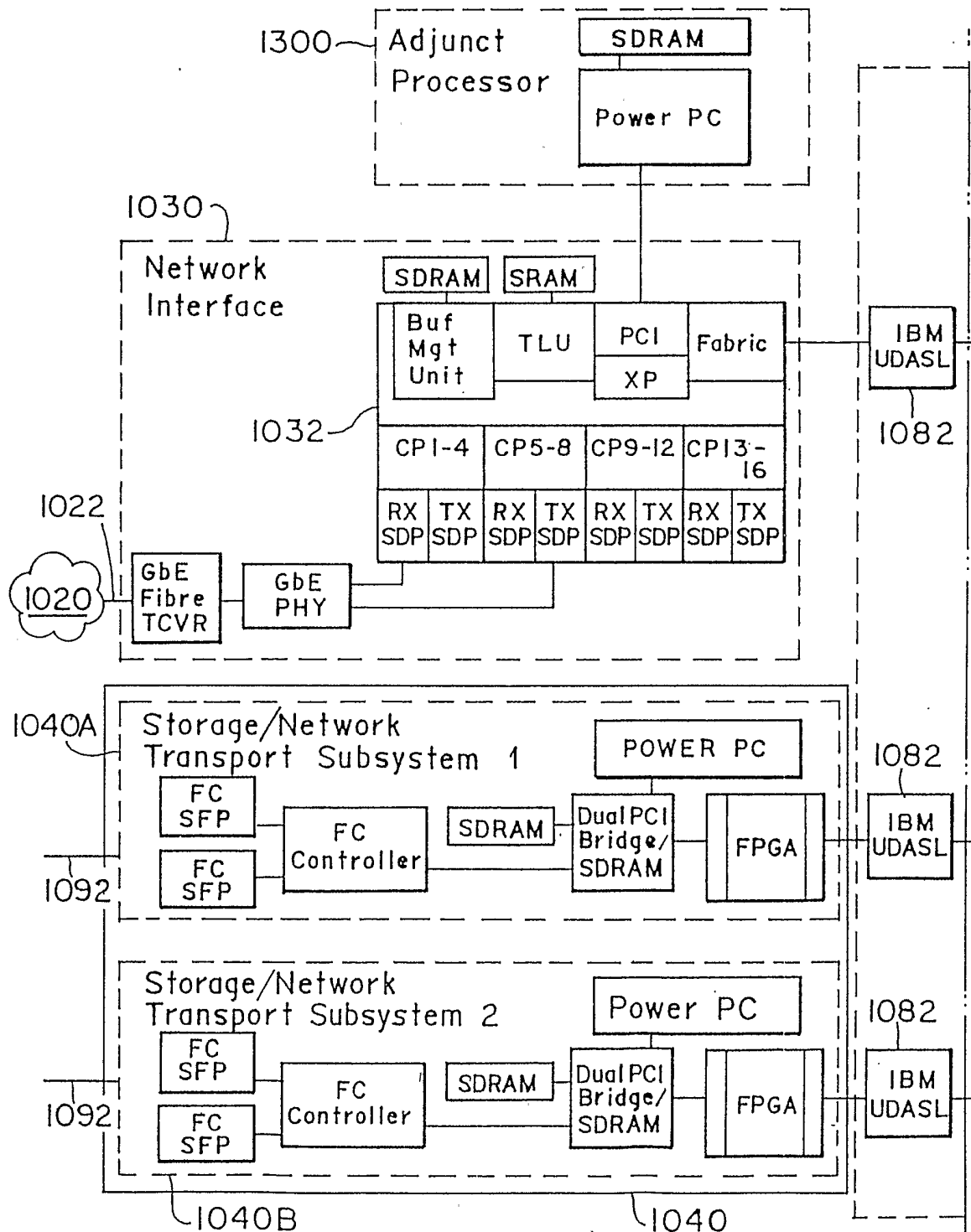

FIG. 1E^I

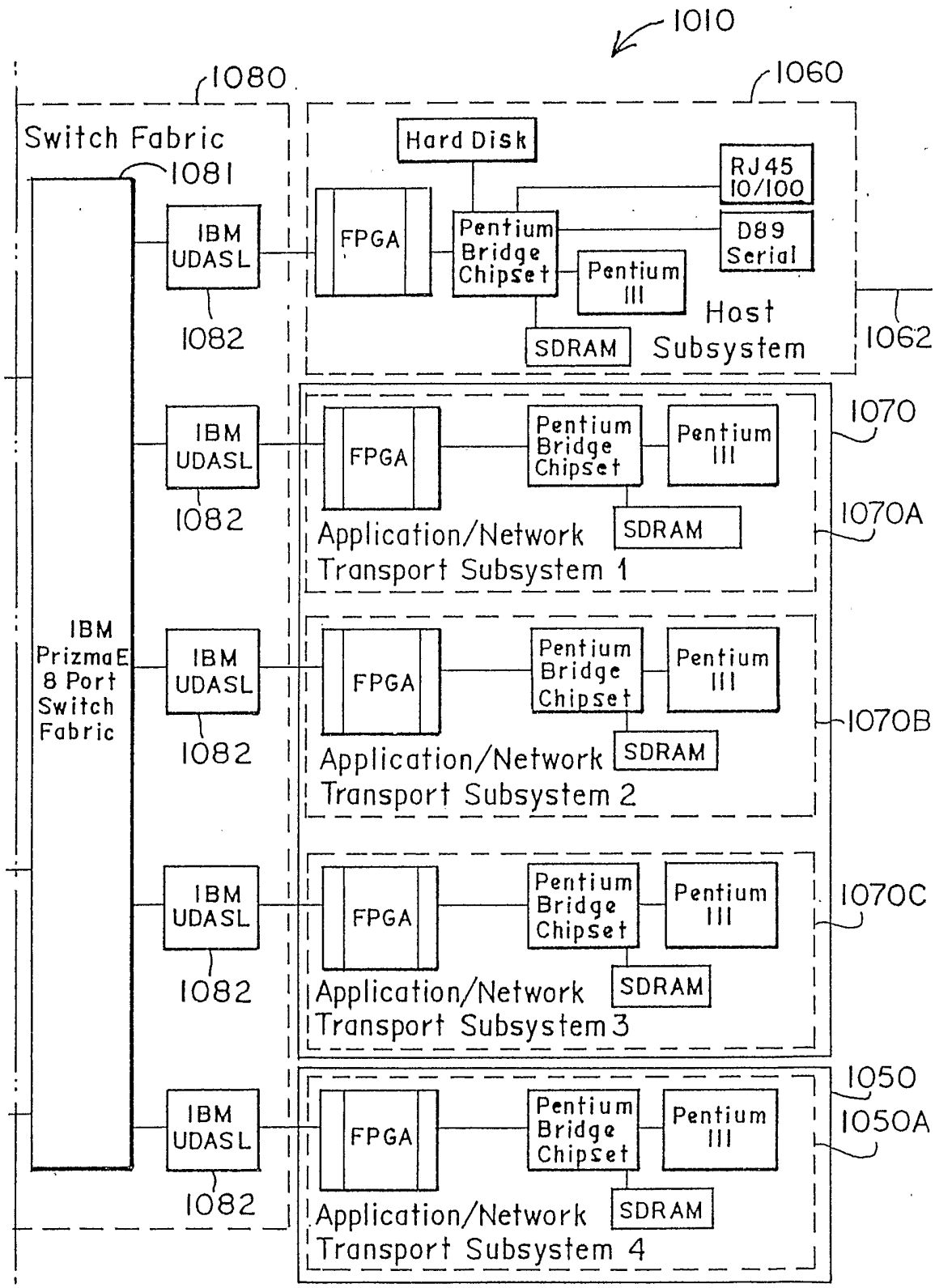

FIG. 1E¹¹

FIG. 1F FIG. 1F^I FIG. 1F^{II}

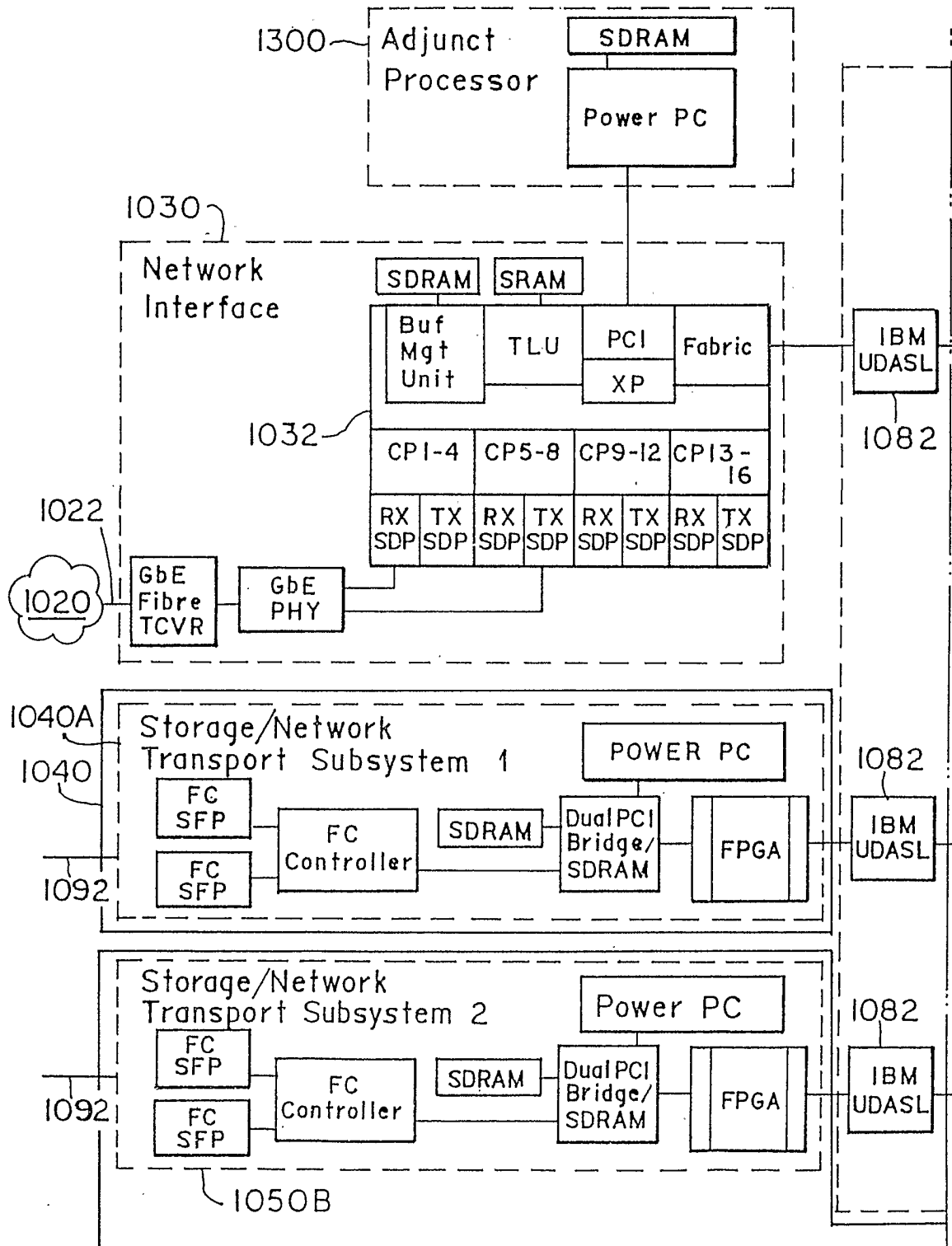

FIG. 1F^I

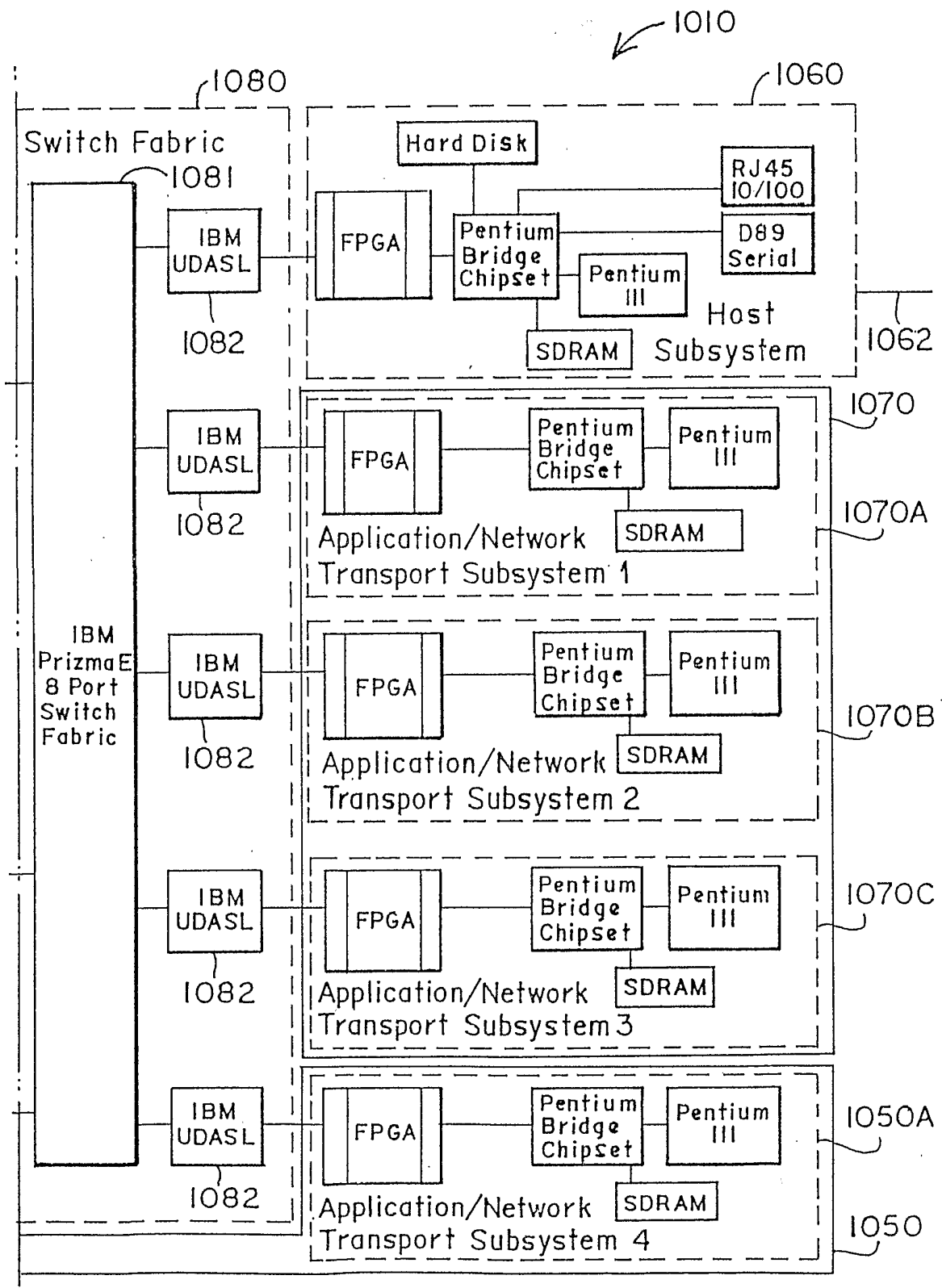

FIG. 1F^{II}

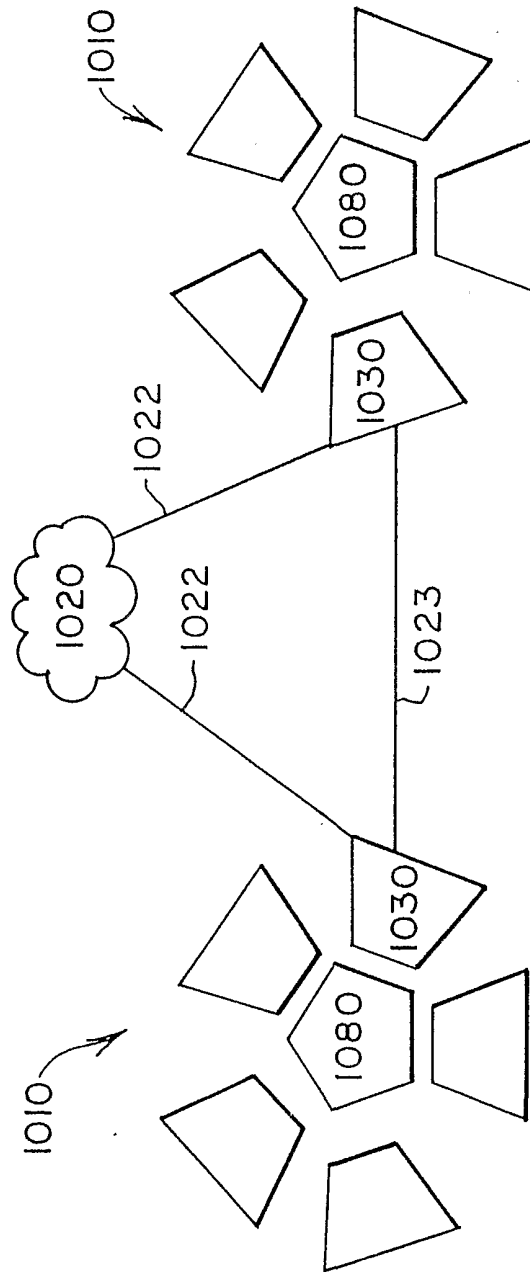

FIG. 1G

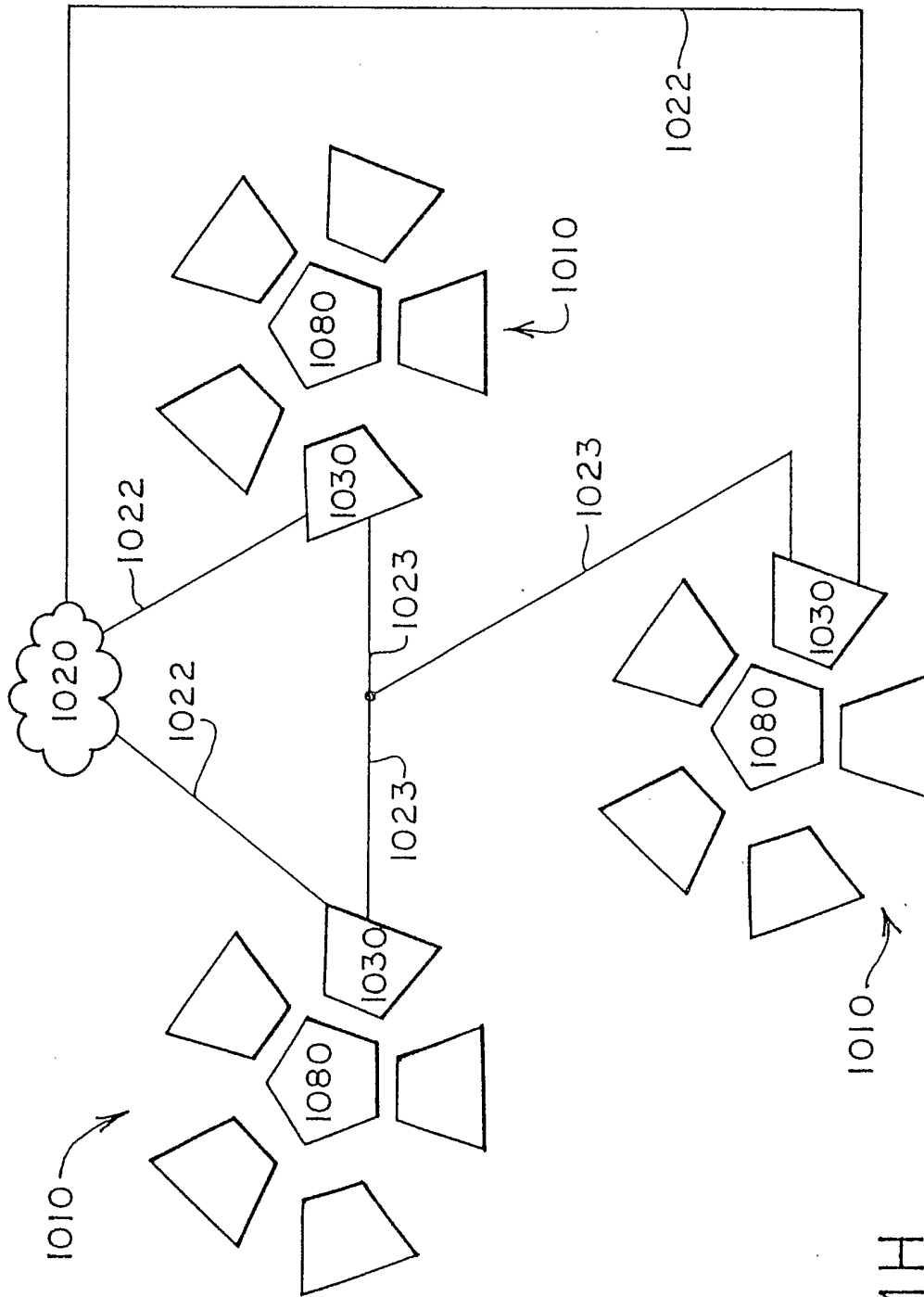

FIG. 1H

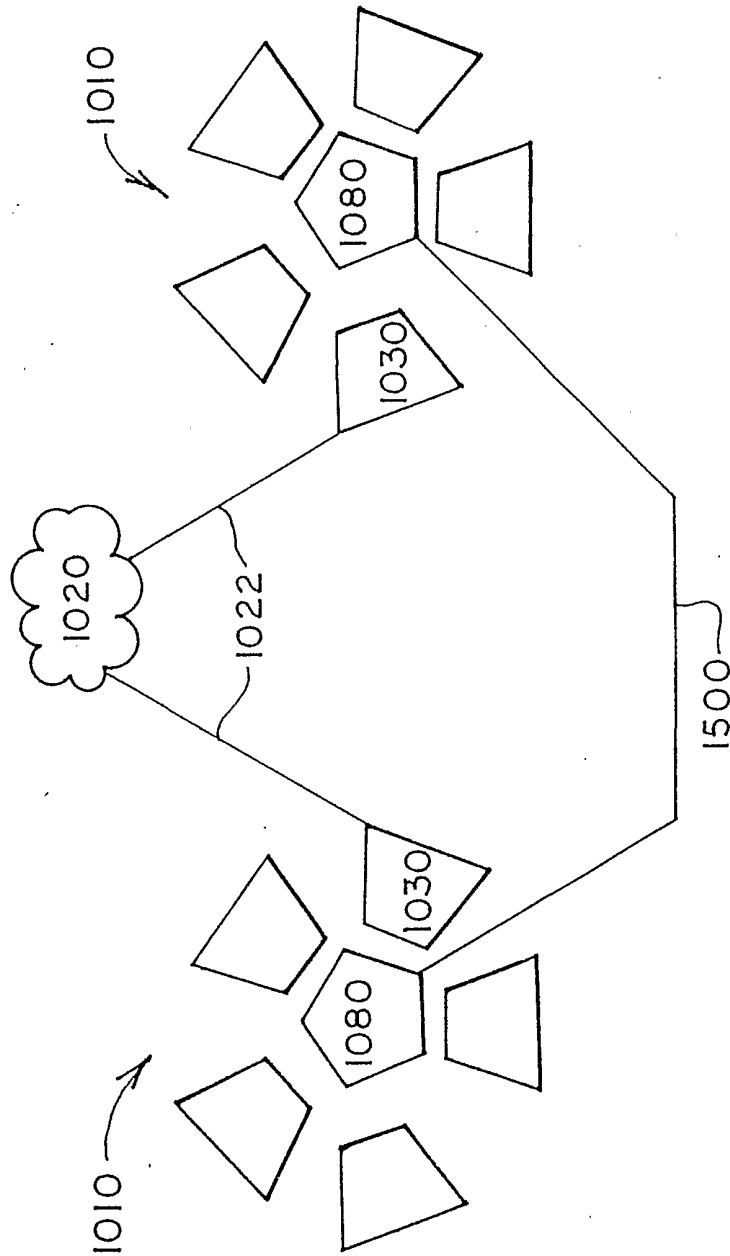

FIG. 1I

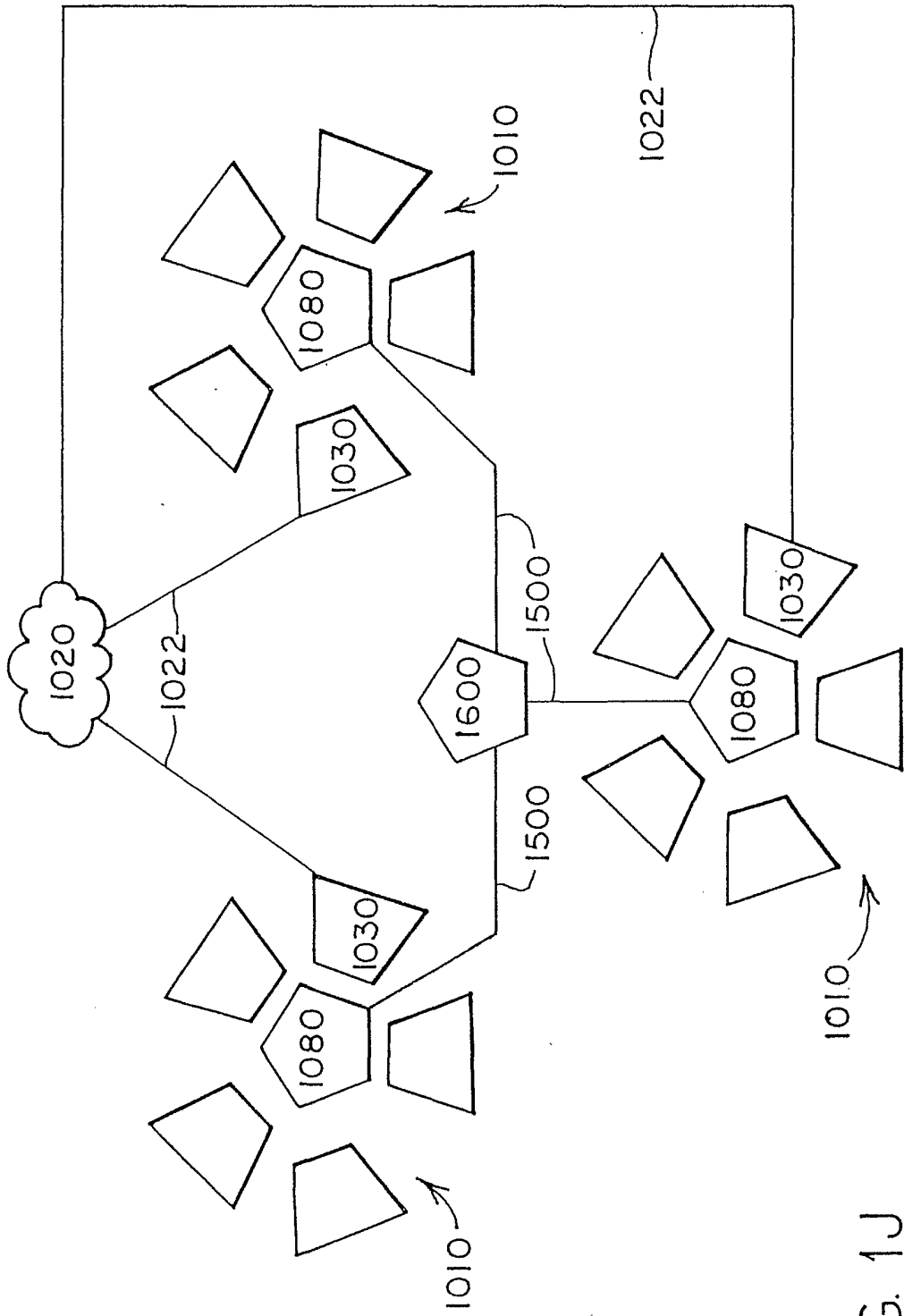

FIG. 1J

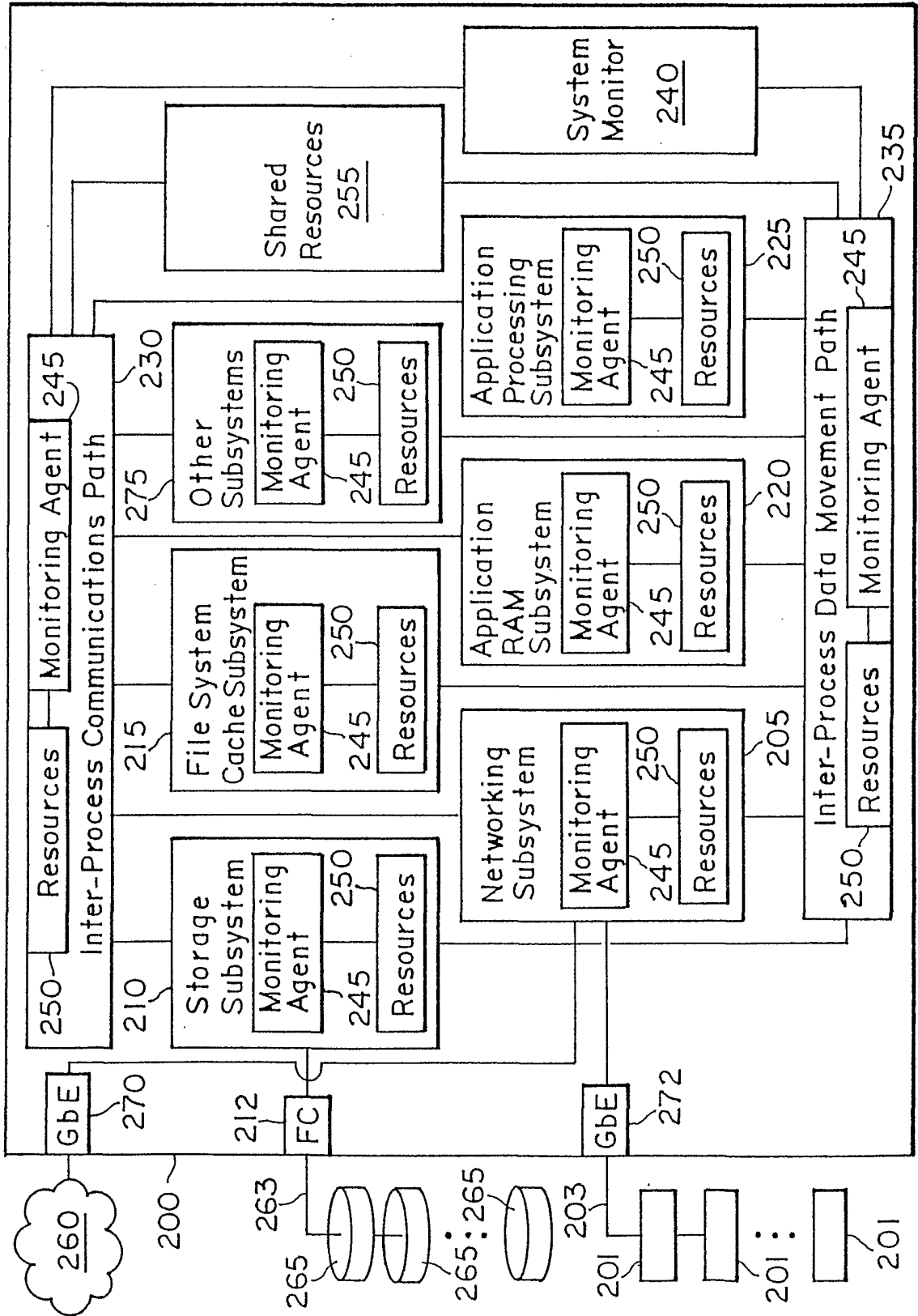

FIG. 2

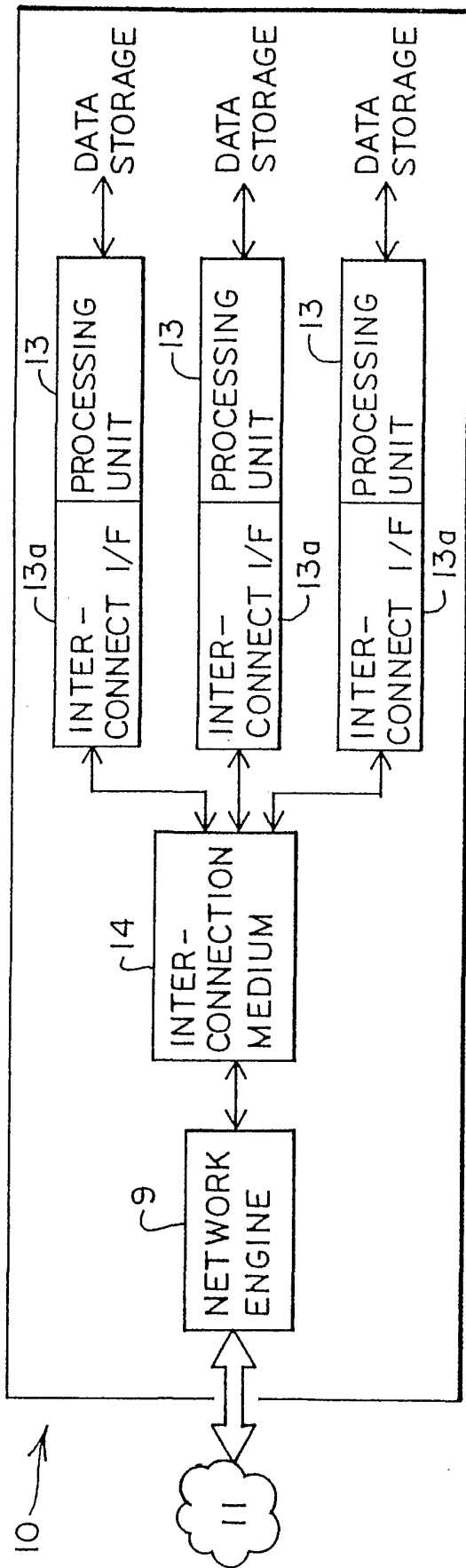

FIG. 2A

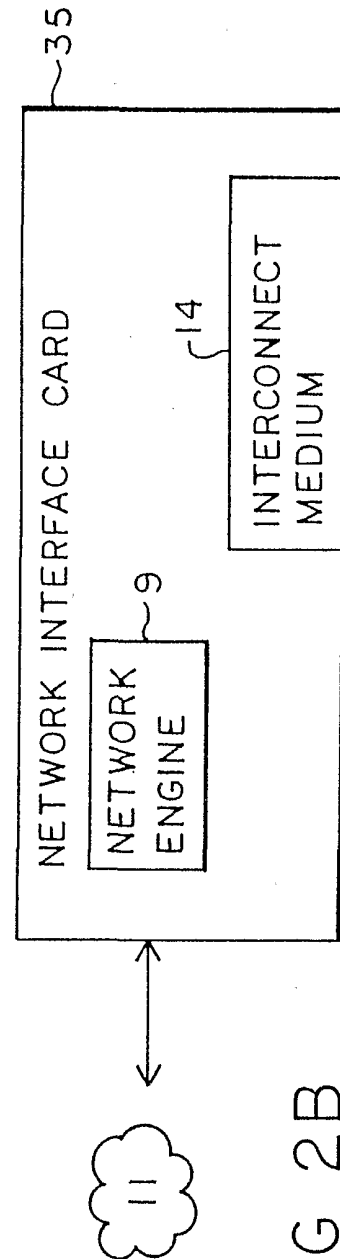

FIG 2B

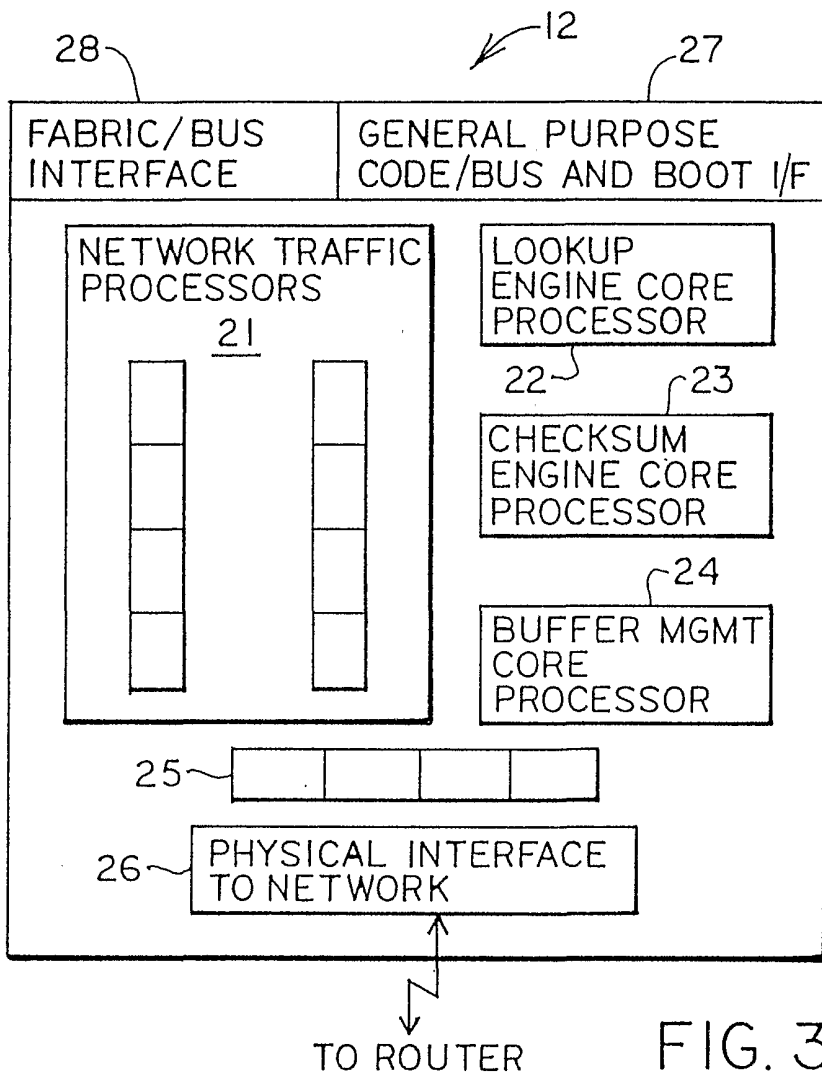

FIG. 3

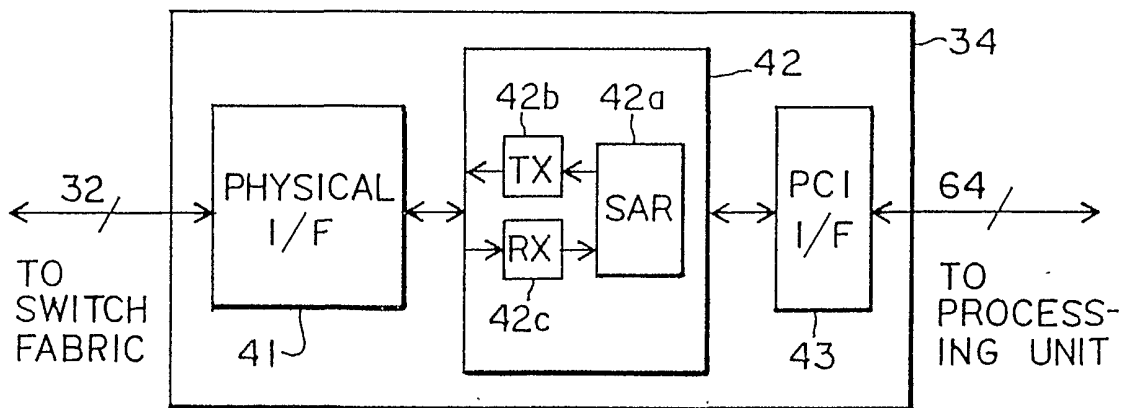

FIG. 4

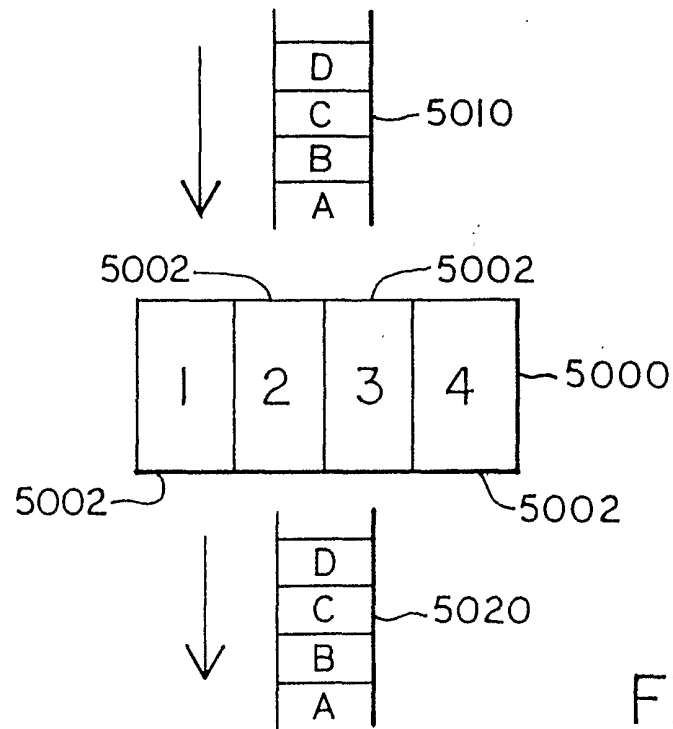

FIG. 5

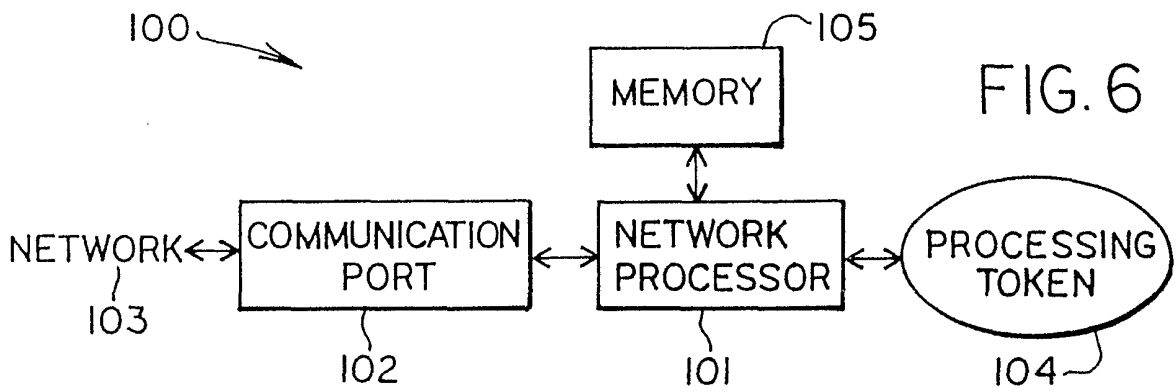

FIG. 6

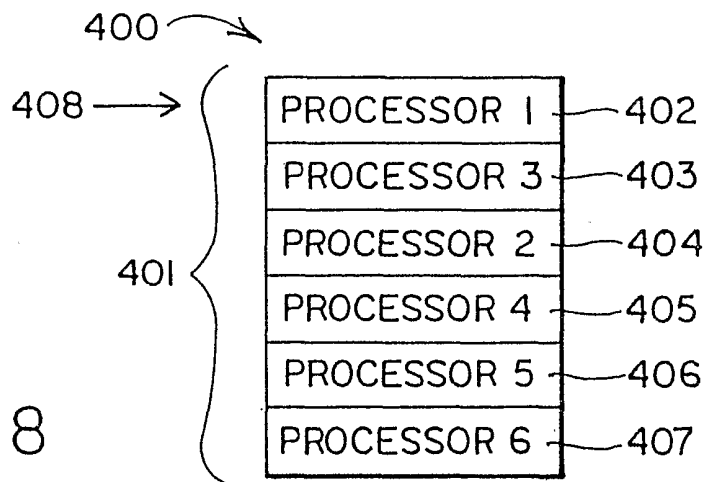

FIG. 8

FIG. 7

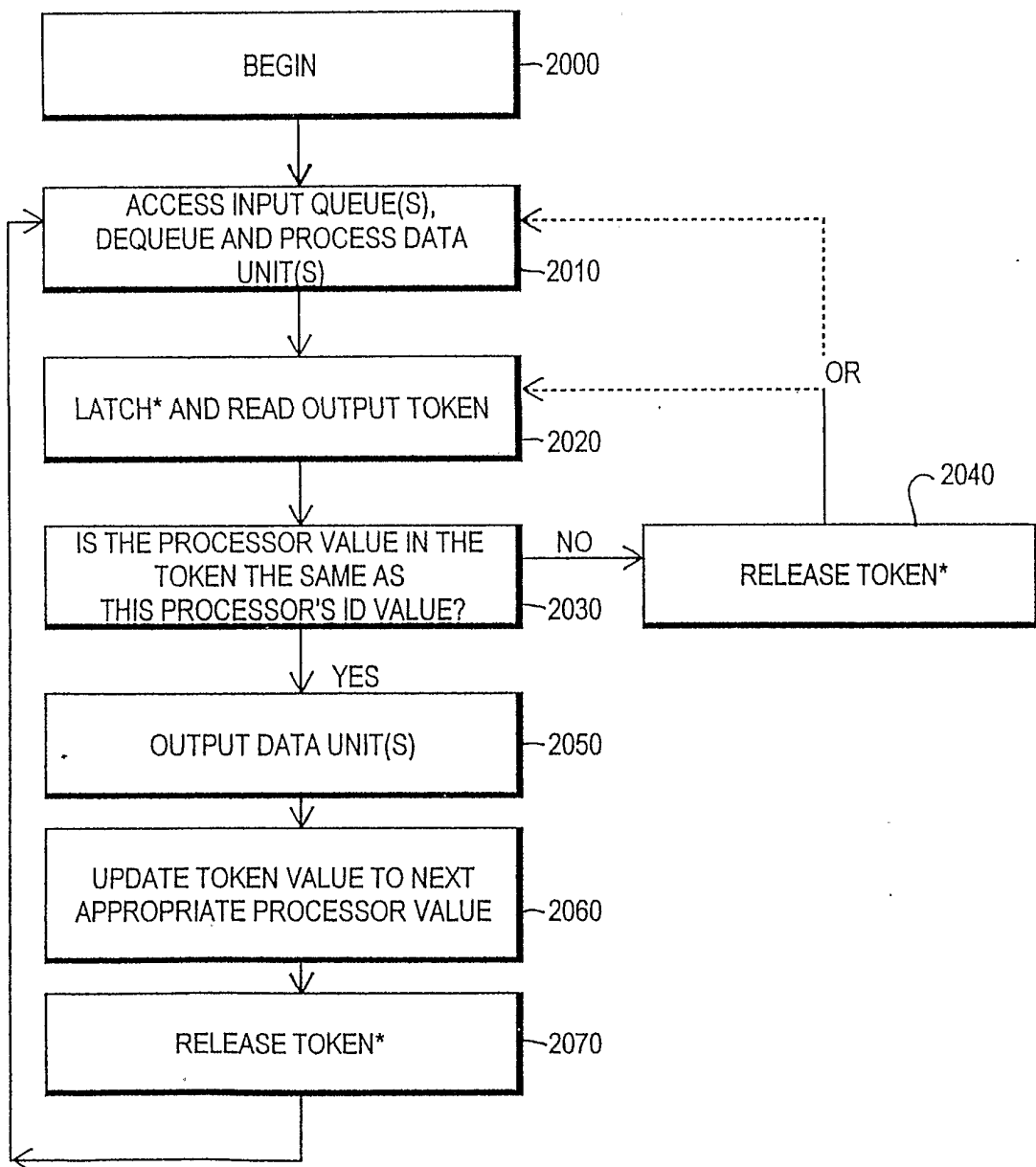

FIG. 9

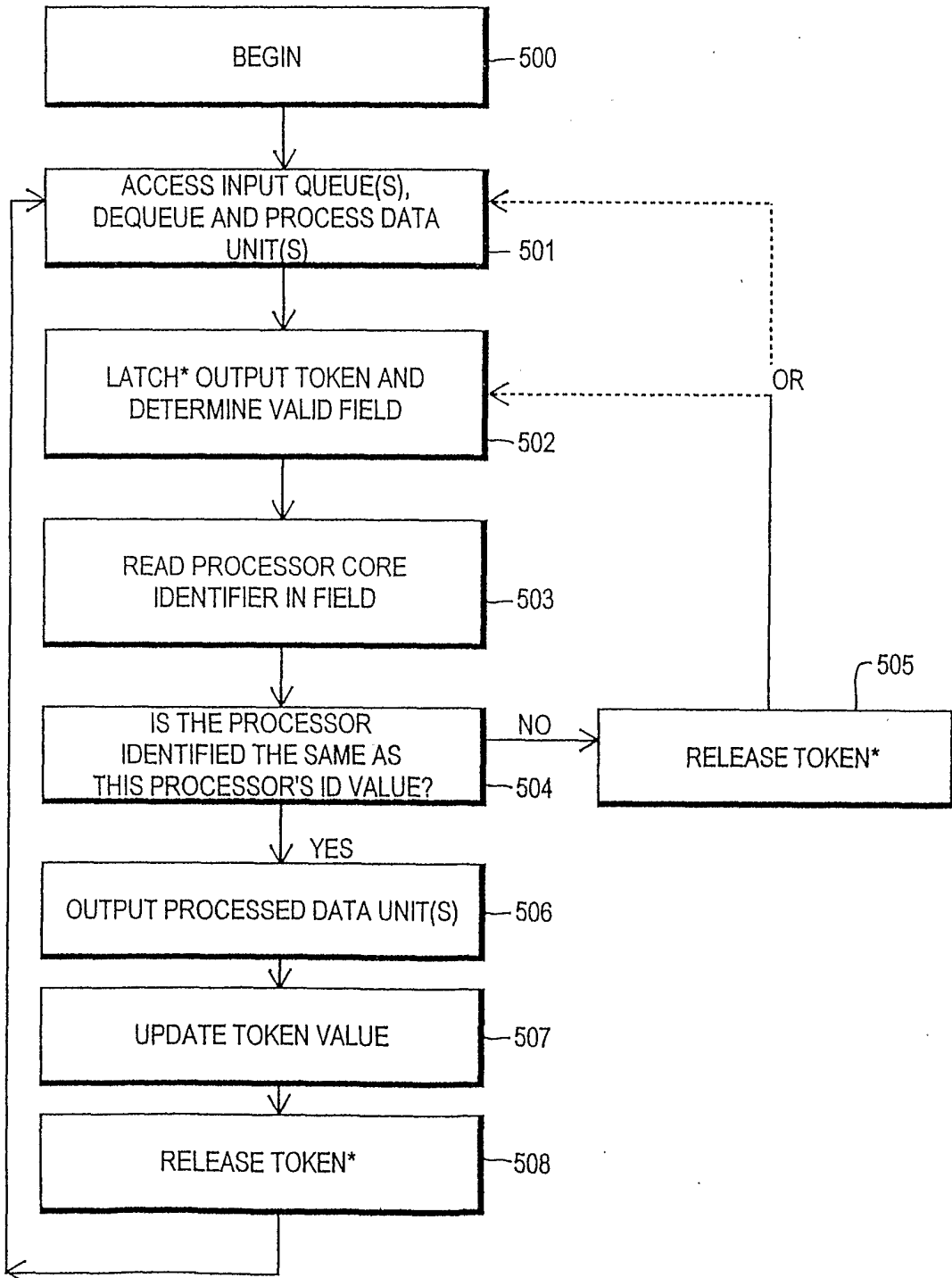
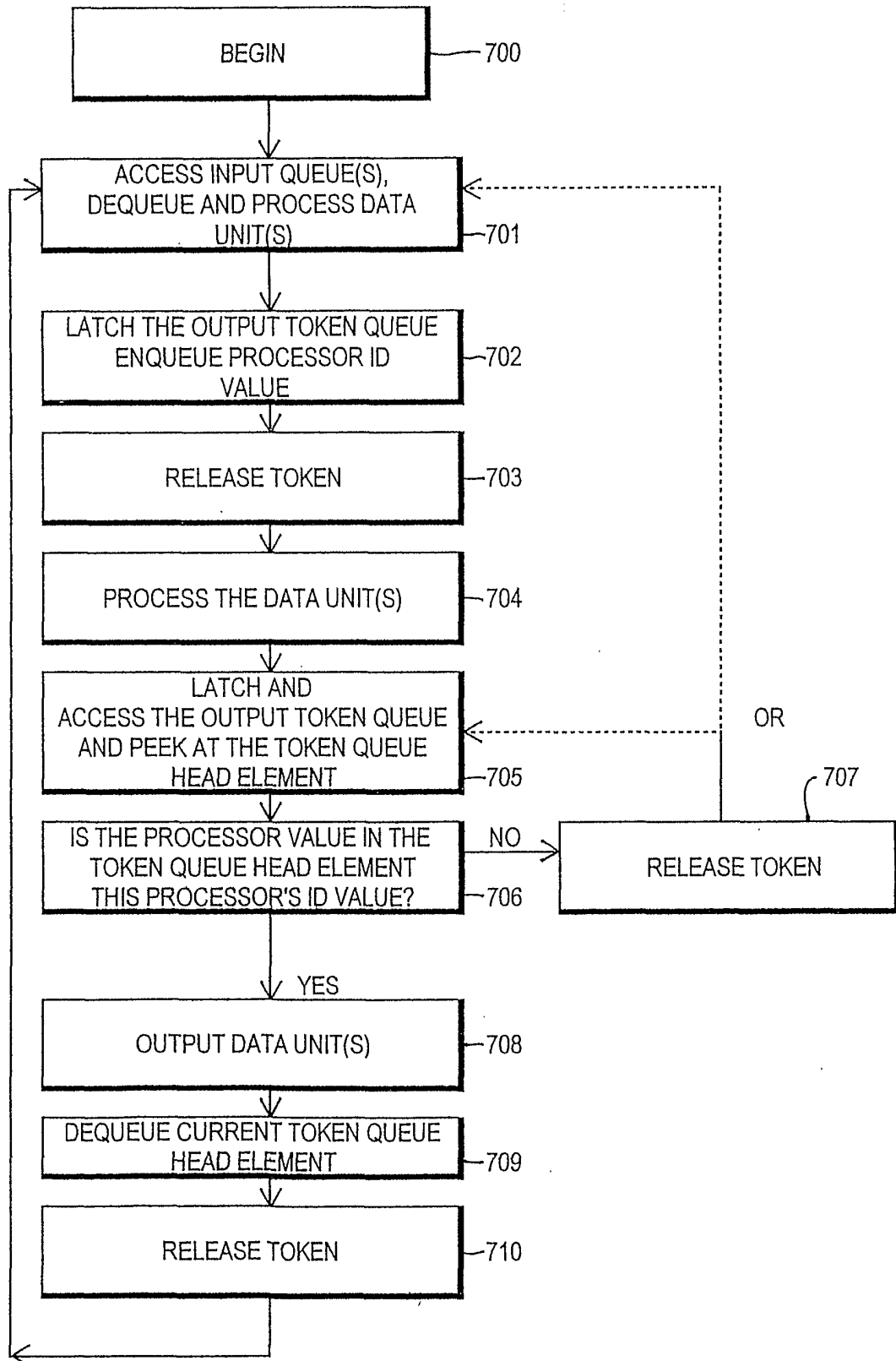

FIG. 10



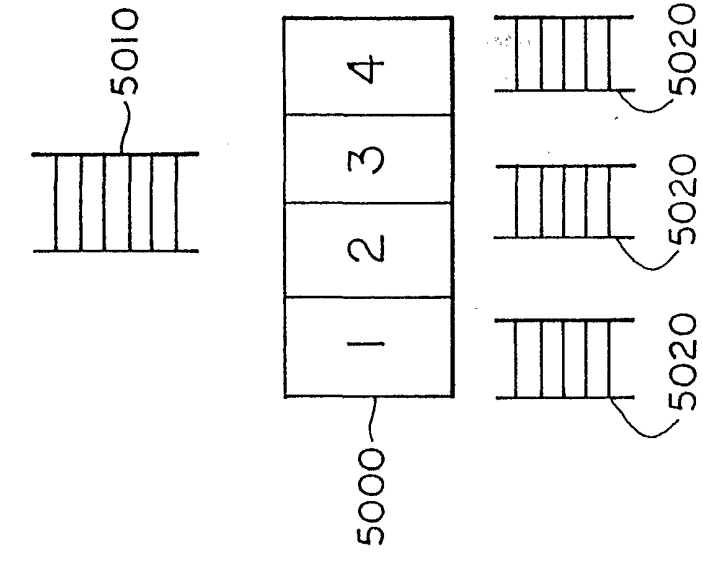

FIG. IIA

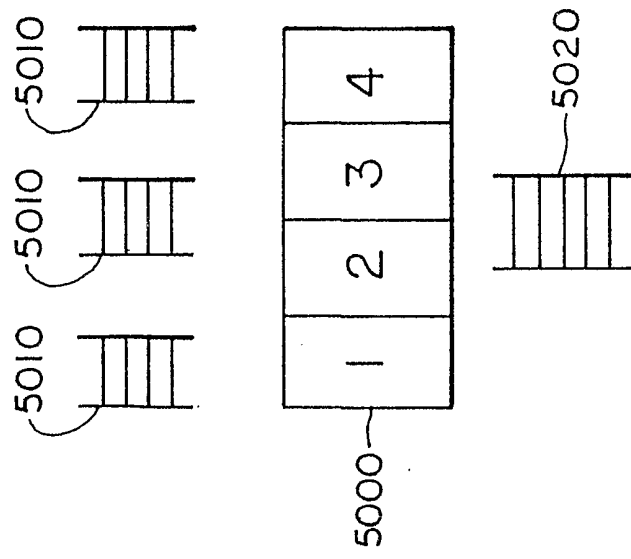

FIG. IIB

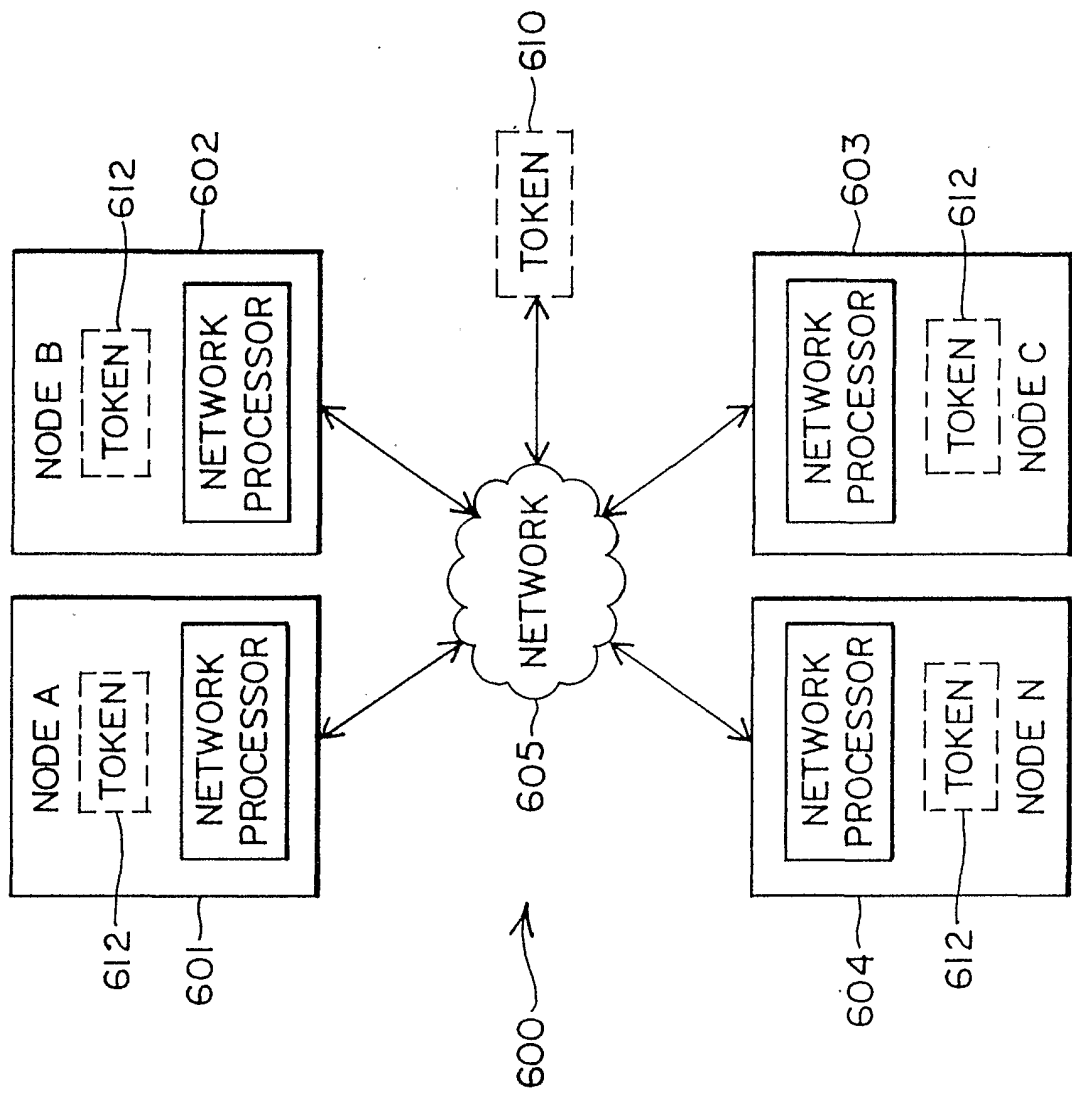

FIG. 12