

Oct. 21, 1958

W. V. BOWMAN ET AL

2,857,085

HOSIERY FORM INSERTING APPARATUS AND METHOD

Filed April 5, 1955

3 Sheets-Sheet 1

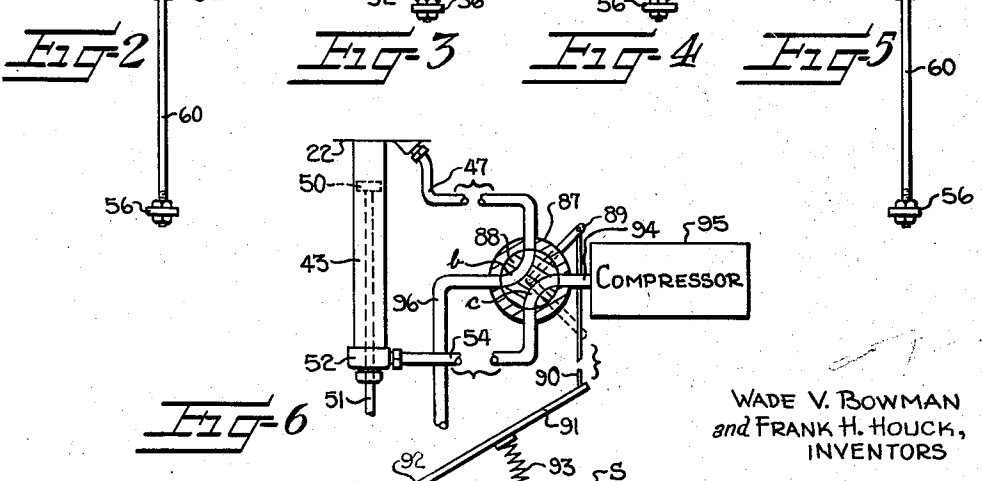
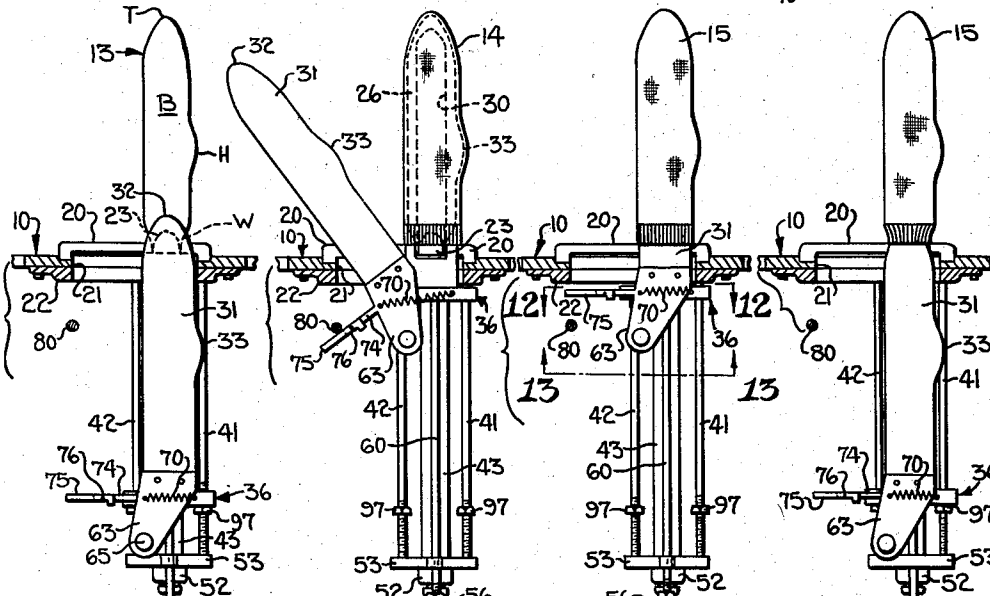
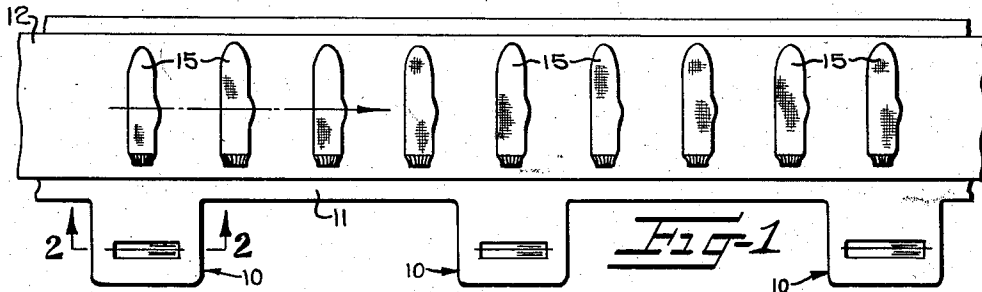

WADE V. BOWMAN
and FRANK H. HOUCK,
INVENTORS

BY *Eaton + Bell*
ATTORNEYS

Oct. 21, 1958

W. V. BOWMAN ET AL

2,857,085

HOSIERY FORM INSERTING APPARATUS AND METHOD

Filed April 5, 1955

3 Sheets-Sheet 2

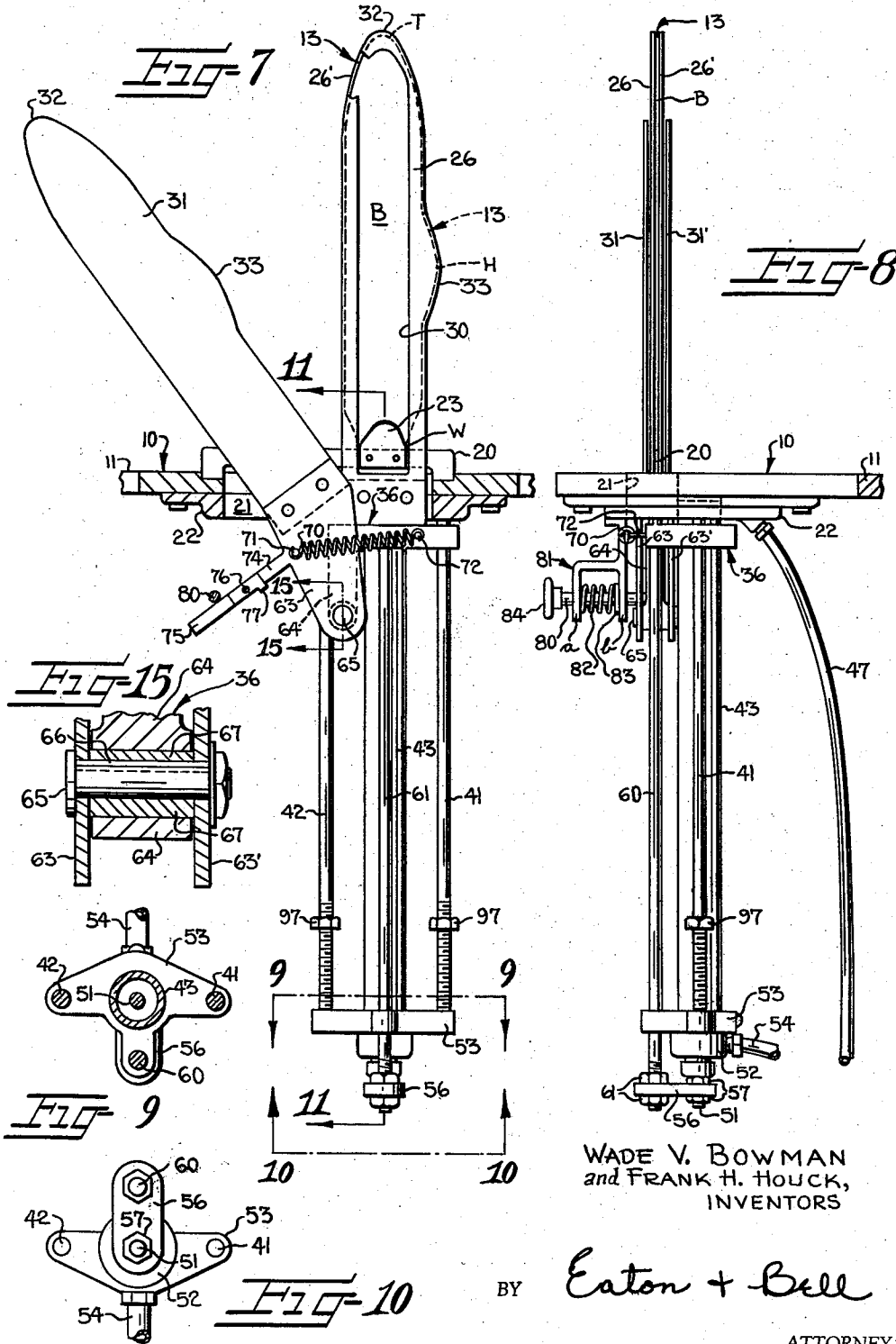

WADE V. BOWMAN
and FRANK H. HOUCK,
INVENTORS

BY *Eaton + Bell*

ATTORNEYS

Oct. 21, 1958

W. V. BOWMAN ET AL

2,857,085

HOSIERY FORM INSERTING APPARATUS AND METHOD

Filed April 5, 1955

3 Sheets-Sheet 3

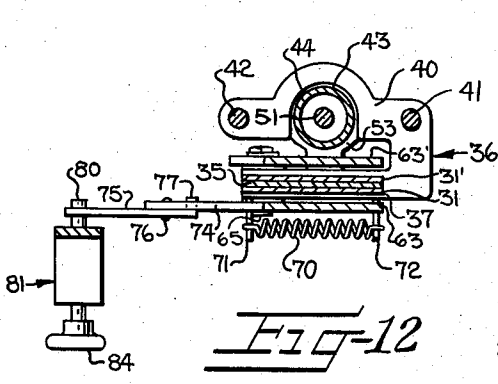

FIG-12

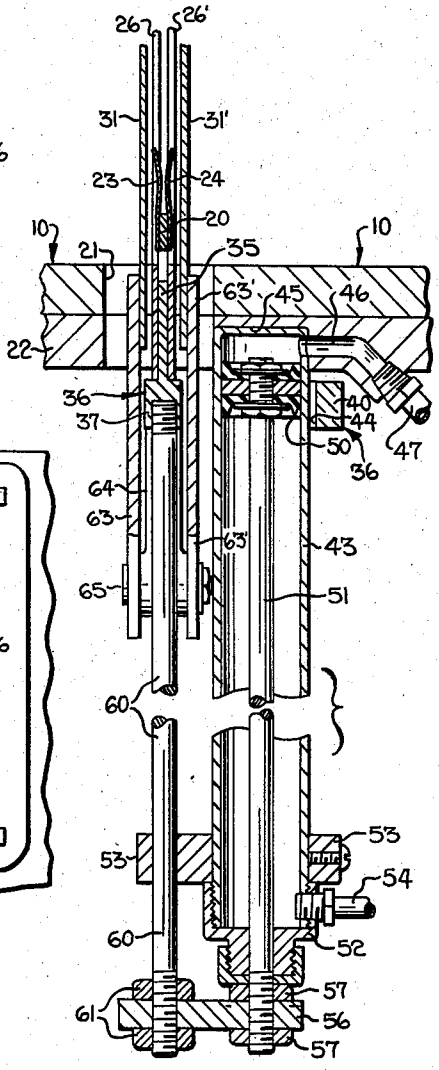

FIG-11

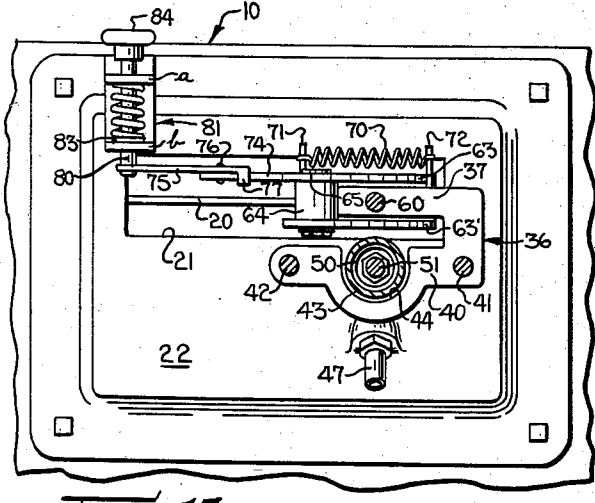

FIG-13

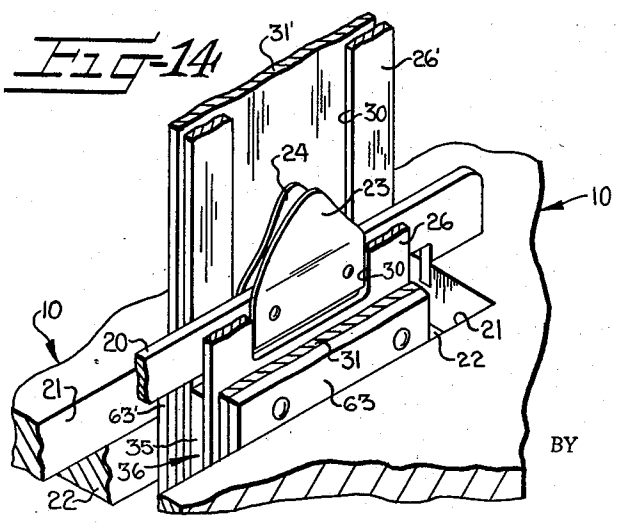

FIG-14

WADE V. BOWMAN,
and FRANK H. HOUCK,
INVENTORS

BY *Eaton + Bell*

ATTORNEYS

2,857,085

HOSIERY FORM INSERTING APPARATUS AND METHOD

Wade V. Bowman and Frank H. Houck, Hickory, N. C.;
said Frank H. Houck assignor to said Wade V. Bowman

Application April 5, 1955, Serial No. 499,392

15 Claims. (Cl. 223—1)

This invention relates to the art of pairing hosiery, and, more especially, to an improved method of and apparatus for placing or mounting pairs of hose, such as men's hose, on rigid or flexible inserts or forms made from paper, cardboard, plastic or the like, preparatory to passing the pairs of hose through subsequent processes and/or maintaining the hose in an elongated, flat state for display purposes.

It is becoming increasingly popular in the displaying of men's hose, particularly those of the so-called stretch type, to mount the two of each pair of hose on a common form or insert so as to not only provide a neat appearance to the display, but to also maintain the originally intended shape of the hose from the time they are manufactured until they are put into use.

Heretofore, the placing of pairs of hose on individual forms has been performed manually and has necessarily been relatively difficult and time-consuming. One of the most outstanding difficulties encountered in the placing of hose on individual forms has been involved in the placing of a second of a pair of hose on a form on which the first hose has been positioned, due to the frictional resistance to relative movement between the hose as the second hose was drawn over the first hose. In some instances, this has caused undue stretching of the second hose and has frequently resulted in imperfections in the hose caused by excessive handling of the hose during this process.

It is therefore an object of this invention to provide a simple and efficient means for and method of positioning pairs of hose or socks on individual forms or inserts which includes the positioning of an insert between a first pair of correspondingly formed blades or guides, then drawing the first hose of a pair over the blades with the insert therebetween and, thereafter, positioning a second pair of blades astride the sock or hose positioned on the first pair of blades, then drawing a second sock or hose over the second pair of blades with the first sock, the first pair of blades and the insert therebetween and then withdrawing the blades or guides from the two socks or hose leaving the insert disposed within the first hose in said pair.

It is another object of this invention to provide an apparatus of the character described including a nest which is preferably stationary, provided with means for receiving and supporting one end of an insert and wherein movable means are provided for supporting corresponding ends of the first and second pairs of form guides or blades. When the insert is positioned in the nest, the toe ends of the inner and outer or first and second pairs of blades or guides are positioned adjacent the welt-supporting portion or end of the insert and means are provided for imparting movement to the blades relative to the nest and the insert, which means function to cause the first or inner pair of blades to move into position astride the insert as the outer or second pair of blades is swung outwardly or out of alignment with the first pair of blades so the first sock or hose in a pair may

be inserted over the first pair of blades and the insert.

Thereafter, the second pair of blades, which are spring-biased, are released to permit the same to move to a position astride the sock or hose positioned on the first pair of blades, whereupon a second sock or hose of said pair is drawn over the second pair of blades, the first hose or sock, the second pair of blades and the insert, simultaneously. Thereafter, movement is again imparted to the first and second pair of blades to withdraw the same from the corresponding hose or socks whereby the pair of hose on the form or insert may be removed from the nest.

Some of the objects of the invention having been stated, other objects will appear as the description proceeds when taken in connection with the accompanying drawings, in which—

Figure 1 is a top plan view of a conveyor showing a few of the improved form inserting devices mounted on the table of the conveyor;

Figure 2 is an enlarged vertical sectional view through one of the improved form inserting devices taken substantially along the line 2—2 in Figure 1, showing the guides or blades in inoperative position and showing a hose insert positioned on the nest;

Figure 3 is a view similar to Figure 2 showing the first or inner pair of blades in elevated or operative position with the second pair of blades positioned to one side thereof and the first hose of a pair positioned about the first pair of blades and the insert;

Figure 4 is a view similar to Figure 3 showing the second pair of blades in operative position with the second hose of a pair positioned thereon;

Figure 5 is a view similar to Figure 4 showing how the form guides are withdrawn from the corresponding hose and away from the insert then disposed within the pair of hose;

Figure 6 is a somewhat schematic diagram showing a preferred form of means for controlling movement of the hose guide forms or blades;

Figure 7 is an enlarged view similar to Figure 3, omitting the first sock or hose in said pair;

Figure 8 is a view looking at the right-hand side of Figure 7;

Figure 9 is a sectional plan view taken along line 9—9 in Figure 7;

Figure 10 is an inverted plan view looking substantially along line 10—10 in Figure 7;

Figure 11 is an enlarged vertical sectional view, with parts broken away, taken substantially along line 11—11 in Figure 7, but omitting the hose insert which is shown in broken lines in Figure 7;

Figure 12 is an enlarged fragmentary sectional plan view taken substantially along line 12—12 in Figure 4;

Figure 13 is an enlarged inverted sectional plan view looking up substantially along line 13—13 in Figure 4;

Figure 14 is an isometric view showing the manner in which the insert supporting means or nest is constructed;

Figure 15 is a fragmentary vertical sectional view taken substantially along line 15—15 in Figure 7.

Referring more specifically to the drawings, the numerals 10 each broadly designate a base, platform or table (Figure 1) for each of the improved form inserting devices in Figure 1. The tables, platforms or bases 10 are parts of a suitable conveyor mechanism 11 with which the improved form inserting apparatus is preferably used and which includes a moving belt 12, onto which each successive pair of hose, with the inserts therein, may be placed by operators adjacent each of the tables, platforms or bases 10. The conveyor mechanism 11 is shown in association with the improved hosiery form inserting devices merely for the purpose of illustrating one of many different means which may be used in association with

the improved hosiery form inserting devices and, since all of the hosiery form inserting devices are identical, only one of them will be described.

As heretofore stated, the improved apparatus is used for inserting a rigid, semi-rigid or flexible form, broadly designated at 13, within a pair of hose, the form 13 being shown in solid lines in Figure 2 and in broken or phantom lines in Figures 3 and 7. The first or inner hose of each pair is generally designated at 14 and the second or outer hose of each pair is generally designated at 15. The hose, socks or stockings shown in Figures 1, 3, 4 and 5 are shown in the form of men's half hose and, while they may be knit from any desired material, forms such as form 13, are usually inserted in hose made from so-called stretch yarns or lively yarns in order to maintain the hose in proper flat shape for subsequent processing and/or displaying of the hose.

The form or insert 13 shown in Figures 3 and 7 is shaped to conform to the usual hose in that it includes an elongated body B which is relatively thin, say, one-sixteenth of an inch thick, and which body B is provided with a rounded toe portion T at one end thereof, a flat-ended, relatively narrow or reduced welt portion W at its other end and a rounded projection or heel portion H on a medial portion of the body B. Of course, the body B and its toe portion T, heel portion H and welt portion W conform substantially to the usual body, toe, heel and welt portions of the hose 14, 15.

The improved hosiery insert inserting apparatus is shown in vertical or upright position in the drawings and the various parts thereof will be hereinafter described as to their relationship with respect to vertical and horizontal planes as shown in the drawings, for purposes of orientation. However, it is to be understood that the attitude of the improved apparatus may be varied and that the improved apparatus may even be inverted when it is used without departing from the spirit of the invention.

The improved insert form inserting apparatus comprises an elongated relatively thin nest bar or insert support 20 which extends longitudinally of and immediately above an elongated opening 21 formed in the base or platform 10 and which opening 21 also extends through a substantially rectangular auxiliary base or cylinder-supporting bracket 22 suitably secured to the lower surface of the main base 10. Opposite ends of the nest bar or hosiery form support 20 preferably are turned downwardly or have downwardly projecting portions thereon which tightly fit in suitable notches provided in the main base 10 adjacent opposite end walls of the slot 21.

A medial portion of the bar or hosiery form support 20 has the lower portions of a pair of upwardly and inwardly bent leaf spring clamping members 23, 24 suitably secured to opposite sides thereof whose upper portions are preferably rounded and flared outwardly in order to facilitate ready insertion of the welt end of a form 13 therebetween. The flat lower edge of the welt portion W of the hosiery insert or form 13 then rests against the upper edge of the nest bar 20 and is thereby maintained in substantially perpendicular relation to the nest bar 20.

Mounted for vertical movement relative to the nest bar 20 and the clamping members 23, 24 is a first or inner pair of closely spaced relatively thin and rigid inserts or form guides or blades 26, 26' which also straddle the nest bar or hosiery form support 20. The major portion of the length of each form guide 26, 26' is of substantially greater width than the leaf spring clamping members 23, 24. In order to accommodate the leaf spring clamping members 23, 24, each of the first or inner form guides 26, 26' is provided with an elongated slot 30 therein of slightly greater width than the corresponding leaf spring clamping member. Vertically movable with the first or inner insert guides 26, 26' is a pair of pivoted

or outwardly movable second or outer, elongated and relatively thin insert guides 31, 31' which normally closely straddle the first or inner insert guides 26, 26'.

The inner or outer insert guides 26, 26' and 31, 31' are all of substantially the same shape and size throughout the major portion of the lengths thereof and are shaped to conform substantially to and are preferably slightly larger than the insert or form 13, to the extent that each of the insert guides has a rounded free end or toe portion 32 and a medial outwardly projecting heel portion 33 thereon which conforms substantially to the toe portion T and the heel portion H of the hosiery insert of form 13.

As best shown in Figures 7, 8, 11, 12, 13 and 14, the lower proximal surfaces of the inner form guides 26, 26' are suitably secured to opposite sides of a relatively thin upwardly projecting portion 35 of a guide block, form guide carriage broadly designated at 36 which is shown in Figures 12 and 13 as being substantially U-shaped in plan. The portion 35 is formed integral with or suitably secured to a leg 37 of the carriage 36 and the other leg of the carriage 36, indicated at 40, is guided for vertical sliding movement on a pair of guide rods 41, 42 disposed astride a vertically disposed cylinder 43.

It will be noted that the leg 40 of the carriage 36 (Figures 12 and 13) is provided with an opening 44 therein through which the cylinder 43 loosely extends. The upper ends of the cylinder 43 and the guide rods 41, 42 are suitably secured to the auxiliary base or bracket 22 closely adjacent the rear wall of the opening 21. In this instance, the upper end of the cylinder 43 is pressed into or otherwise secured in a cavity 45 formed in the lower surface of the bracket 22 (Figure 11) and the bracket 22 has a passageway 46 therein which communicates with the interior of the upper end portion of the cylinder 43. One end of a fluid pressure conduit 47 is connected to the bracket 22 for communication with the passageway 46 to thereby introduce fluid pressure, such as hydraulic fluid or compressed air, into the upper end of the cylinder 43 or to permit escapement of the fluid pressure from cylinder 43, as desired.

A piston 50, mounted for longitudinal or vertical sliding movement in the cylinder 43, has one end of a piston rod 51 connected thereto which penetrates a cylinder closure or head 52 fixed on the lower end of cylinder 43. The lower portion of cylinder 43 has a guide bracket 53 fixed thereon which is shown in Figures 9 and 10 as being substantially T-shaped in plan and to which the lower ends of the guide rods 41, 42 are secured. The lower portion of cylinder 43 has one end of a pipe or conduit 54 communicatively connected thereto (Figures 6, 8 and 11).

The free lower end of the piston rod 51 slidably or loosely penetrates a cuff member or arm 56 which is adjustably secured on piston rod 51 by means of a pair of lock nuts 57. The bar or cuff member 56 is also loosely penetrated by the lower portion of a plunger or guide rod 60 which is adjustably secured in the bar or cuff member 56 by means of a pair of lock nuts 61. The guide rod 60 is guided for longitudinal movement in the T-shaped bracket 53 and its upper end is fixed to the leg 37 of the substantially U-shaped blade carriage 36. It is thus seen that introduction of fluid pressure alternately into opposite ends of the cylinder 43 will cause corresponding upward and downward movements to be imparted to the guide carriage 36 and the inner or first pair of blades or form guides 26, 26'.

Now, it will be observed in Figures 7, 11 and 14 that the lower ends of the second or outer form guides 31, 31' have respective extensions 63, 63' secured thereto or formed integral therewith. The extensions 63, 63' straddle the leg 37 of carriage 36 and are pivotally connected to the lower end of an arm 64 depending from the free end of leg 37 of carriage 36. Since the outer or second pair of form guides 31, 31' must move or pivot in unison,

the lower portions of the extensions 63, 63' are preferably fixed on opposite end portions of a stud or shoulder bolt 65, as by a key 66 (Figure 15). The outer blade or form guide extensions 63, 63' engage opposite ends of a bushing 67 which is also keyed to the stud or shoulder bolt 65 by the key 66. The bushing 67 is oscillatably mounted in the lower end of the arm 64 depending from the leg 37 of carriage 36.

The outer or second blades or form guides 31, 31' are normally urged to a position in parallel coinciding relationship with the inner blades or form guides 26, 26' by any suitable means such as a tension spring 70, one end of which is connected to a spring anchor 71 projecting outwardly from the extension 63 of the blade 31 and the other end of which is connected to a spring anchor 72 suitably secured to and projecting outwardly from the leg 37 of carriage 36. The spring anchor 72 also serves as a stop or limiting means, since the spring 70 urges the right-hand edge of the extension 63 in Figures 2, 3, 4, 5 and 7 into engagement with the spring anchor 72 and the spring anchor or stop 72 is so positioned that the blades 31, 31' are then in parallel coinciding relationship with the inner or first blades 26, 26' as shown in Figures 2, 4, 5, 12 and 14.

An arm 74 extends laterally from a medial portion of extension 63 of blade 31 and has a pivoted dog or latch 75 mounted thereon, as at 76. The pivoted latch or dog 75 is overbalanced, or may be suitably spring urged, so that it normally extends in substantial alignment with the arm 74, its movement in a counterclockwise direction in Figures 2, 3, 4, 5 and 7 being limited by a projection 77 on the latch 75 engaging the lower surface of the arm 74. The latch 75 is disposed in the vertical plane of a manually releasable outer blade tilting means shown in the form of a detent, pin or shaft 80 mounted for substantially horizontal sliding movement in legs *a*, *b* of a substantially h-shaped bracket 81 suitably secured to and depending from the auxiliary base plate 22 (Figures 8, 12 and 13).

It will be noted that the pin or detent 80 is encircled by a compression spring 82, one end of which engages the leg *a* and the other end of which engages an enlarged portion or collar 83 fixed on the pin or detent 80 and which collar 83 is normally urged against the inner surface of the leg *b*. The end of the detent or pin 80 remote from the vertical plane of the latch 75 has a suitable handle or knob 84 thereon for manipulation by an operator. It will be noted that the position of the detent or pin 80 relative to the base 10 and the length of the slot 21 in the base 10 is such that the blades 31, 31' are swung outwardly clear of the portions of the blades 26, 26' which straddle the insert 13 when the blades 26, 26' are in fully raised or operative position.

Any desired means may be provided for imparting longitudinal movement to the plunger or guide rod 60 and the ram embodied in the piston 51 and the double-acting cylinder 43 are merely shown as a preferred means for controlling movement of the rod or plunger 60. It will be observed in Figure 6 that the ends of the conduits 47, 54 are connected to a suitable four-way valve, shown schematically at 87 in Figure 6, provided with a movable or rotatable core 88 to which one end of a lever 89 is secured. The free end of lever 89 has a link 90 connected thereto whose other end is connected to a treadle bar or pedal 91 pivotally mounted, as at 92, on the floor or surface *S* which supports the platform or base 10. It is apparent that suitable legs, not shown, would be provided for supporting the base 10 in spaced relationship above the surface *S*.

The pedal 91 is normally urged upwardly by a compression spring 93 and it will be noted that the valve 87 has a fluid pressure inlet conduit or pipe 94 connected thereto which extends to a suitable source of fluid pressure indicated at 95. The valve core 88 has passageways *b*, *c* therein. When the pedal 91 is in raised position, passageway *c* establishes communication between the pipe or

conduit 94 and the conduit 54 and the passageway *b* then establishes communication between the pipe or conduit 47 and a return or discharge conduit or pipe 96. Thus, with the valve core 88 in the position shown in Figure 6, fluid pressure is introduced to the lower end of the cylinder 43 as it is exhausted from the upper end thereof so the blades 26, 26', 31, 31' occupy raised position such as that shown in Figures 3, 4, 7, 8, 11 and 14.

Of course, when pedal 91 (Figure 6) is moved downwardly, to move the lever 89 to the broken line position, the direction of flow of fluid pressure is reversed and this imparts downward movement to the blades or form guides 26, 26', 31, 31'. This downward movement is limited by a pair of adjustable limiting members shown in the form of nuts 97 mounted on the guide rods 41, 42. The nuts 97 are then engaged by the lower surface of the leg 40 of the carriage 36.

In operation, the carriage 36 and the blades 26, 26', 31, 31' are lowered, by depressing pedal 91 in the manner heretofore described, so the carriage and blades occupy substantially the position shown in Figure 2. A hosiery form or insert 13 is then positioned upon the nest bar 20 and clamped between the leaf spring clamping members 23, 24, whereupon the pedal 91 is released to permit fluid pressure to enter the lower end of the cylinder 43 as it is exhausted from the upper end thereof. Thus, the piston 50 and the piston rod 51 move upwardly to impart corresponding movement to the guide rod or plunger 60 and the carriage or the bracket 36.

In the course of upward movement of the carriage 36, the latch 75 engages the detent 80 so that, with further upward movement, the outer blades 31, 31' are swung outwardly away from the inner blades 26, 26'. It will be noted that the inner pair of blades 26, 26' then move upwardly to occupy positions astride the hosiery form or insert 13 so an operator may then draw the first hose 14 of a pair over the pair of inner blades 26, 26' and the hosiery form or insert 13 as shown in Figure 3.

The operator then pulls the pin or detent 80 out of engagement with the latch 75 so the spring 70 then swings the blades 31, 31' from the position shown in Figure 3 to that shown in Figure 4. The second hose 15 of said pair is then drawn downwardly over the blades 31, 31' and will, of course, be drawn about the previously positioned hose 14, the blades 26, 26' and the insert 13. It will be noted that, since the clamping members 23, 24 are disposed in the slots 30, they do not project outwardly beyond the inner blades or form guides 26, 26' and will not, therefore, interfere with the positioning of hose on the inner blades or form guides 26, 26'.

After the second hose 15 of said pair has been positioned over the outer or second pair of blades 31, 31', the pedal 91 is again depressed to impart downward movement to the carriage 36 and the blades 26, 26', 31, 31' to withdraw said blades from the corresponding hose 13, 14. The upper end wall of each slot 30 is preferably rounded to conform to the shape of the clamping members 23, 24. This permits the blades to be lowered to where only a small area of each toe portion 32 straddles the nest clamps 23, 24 and the insert 13.

Although the detent 80 may occupy operative position, that is, is disposed in the vertical plane of the latch 75, during downward movement of the carriage 36 and the blades, it is apparent that the latch 75 will merely swing upwardly as it engages the detent 80 and when it has passed the detent, the latch will then return to the substantially horizontal position shown in Figures 2 and 5. It will be noted that, as the toe portions 32 of the blades 26, 26', 31, 31' move downwardly to substantially the position shown in Figure 5, the welts of the corresponding hose move inwardly to conform to the reduced welt portion of the hosiery insert 13.

A cycle in the operation of the improved hosiery form inserting apparatus is then completed and it is merely necessary for the operator to grasp the hose on the insert

7

and withdraw the insert from between the clamping members 23, 24 and place the same on the conveyor belt 12 for advancing them to a subsequent process such as heat-setting or packaging.

It is thus seen that I have provided a novel method and means which facilitates quick and easy insertion of inserts in pairs of hosiery and which practically eliminates any possibility of the hose being damaged during the course of the operation.

In the drawings and specification there has been set forth a preferred embodiment of the invention and, although specific terms are employed, they are used in a generic and descriptive sense only and not for purposes of limitation, the scope of the invention being defined in the claims.

We claim:

1. A method of mounting a first stocking on a hosiery form and a second stocking on the first stocking utilizing rigid form guides which includes the steps of positioning the hosiery form between and in substantially coinciding relation to a first pair of said guides, drawing the first stocking onto the first pair of guides and, thus, over the hosiery form, then positioning the first pair of guides, with the first stocking thereon, between and in substantially coinciding relation to a second pair of said guides, drawing the second stocking onto the second pair of guides and, thus, over the first stocking, then withdrawing the guides from the stockings while leaving the hosiery form in the first stocking.

2. A method of drawing pairs of hose onto corresponding inserts which includes the steps of supporting one end of an insert in fixed relation to a first pair of insert guides corresponding substantially to the shape of the insert, moving the first pair of guides into position astride the insert, drawing a first hose of a pair onto said first pair of insert guides simultaneously, thereafter positioning a second pair of insert guides astride the first hose on the first pair of insert guides and in coinciding relationship with the first pair of insert guides, thereafter positioning a second hose of said pair over the second pair of insert guides and then withdrawing all of the insert guides from the corresponding hose.

3. Apparatus for drawing a pair of hose onto an elongated relatively thin insert comprising a first pair of guide forms conforming in shape substantially to the shape of the insert, a second pair of guide forms also conforming in shape substantially to the first pair of guide forms, means to support one end of said insert adjacent and between corresponding ends of the first and second pair of guide forms, means to move the first pair of guide forms astride and into position parallel to and coinciding with the insert whereby a first hose of a pair may be drawn over the first pair of guide forms and the insert, means to then position the second pair of guide forms in side-by-side relationship with the first pair of guide forms astride the hose positioned on the first pair of guide forms whereby a second hose may be drawn over the second pair of guide forms, and means for withdrawing the guide forms from the hose whereby the hose are then supported solely on the insert.

4. A structure according to claim 3 wherein said means to support the insert comprises a relatively thin nest bar, a pair of clamp members carried by the nest bar and being biased toward each other for clamping a portion of said insert therebetween, said means to move the first pair of guide forms being arranged to move the first pair of guide forms longitudinally of the insert and in close proximity to opposite sides of the nest bar, and each guide form in the first pair having a longitudinal slot therein in which said clamp members are disposed.

5. Apparatus for drawing a pair of hose onto an elongated relatively thin insert comprising a substantially vertically movable carriage, a first pair of closely spaced substantially upright guide forms carried by the carriage and conforming in shape substantially to the shape of

8

the insert, a second pair of guide forms disposed astride the vertical plane of said first pair and being pivotally mounted on said carriage and also conforming in shape substantially to the first pair of guide forms, stationary means to support one end of said insert adjacent and between corresponding ends of the first and second pairs of guide forms, means to raise and lower the carriage to move the first pair of guide forms into position parallel to and coinciding with the insert when the carriage is raised, a latch pivotally connected to at least one guide form of the second pair, means limiting downward movement of the latch relative to the corresponding guide form, a manually movable member normally disposed in the vertical plane of the latch whereby the second pair of guide forms is moved from a position coinciding with the first guide forms to one side of the first pair of guide forms as the carriage is raised so a first hose of a pair may be drawn over the first pair of guide forms and the insert, means to urge the second pair of guide forms from said position to one side of the first pair of guide forms to a position in side-by-side relationship with the first pair of guide forms and astride the hose positioned on the first pair of guide forms as said manually movable member is moved out of engagement with said latch whereby a second hose may be drawn over the second pair of guide forms, and whereby lowering the carriage will withdraw the guide forms from the hose so the hose are then supported solely on the insert.

6. Apparatus for inserting elongated flat and relatively thin hosiery inserts in pairs of hose comprising a base having a slot therein, a nest bar extending over said slot and having a pair of clamping members fixed thereto between which one end of a hosiery insert may be positioned, a first pair of closely spaced relatively thin hosiery guide forms conforming in shape substantially to the shape of the insert and being movable through said slot closely astride opposite sides of said nest bar, a second pair of guide forms corresponding in shape substantially to the shape of the first pair of guide forms and normally straddling and coinciding with the first pair of guide forms, means for moving the guide forms in unison from a position astride said hosiery insert to a position adjacent one end of the hosiery insert to expose said hosiery insert, means for moving said guide forms back to the original position astride the hosiery insert, means automatically operable in the course of movement of the first pair of guide forms into alinement with the hosiery insert for moving the second pair of guide forms outwardly with respect to the first pair of guide forms whereby a first hose of a pair may be inserted over the first pair of guide forms and the insert, means normally urging the second pair of guide forms into parallel alinement with the first pair of guide forms, means for releasing the second pair of guide forms whereby they will move into alinement with the first pair of guide forms and whereby a second hose of said pair may be drawn over the second pair of guide forms, the first hose, the first pair of guide forms and the insert simultaneously so that, with subsequent movement of the guide forms away from the insert, the guide forms are withdrawn from the hose and the hose with the insert therein may then be removed from the nest bar.

7. Apparatus for inserting elongated flat and relatively thin inserts in pairs of hose comprising a substantially horizontal base having a slot therein, a nest bar extending over said slot and having a pair of clamping members fixed thereto between which the lower end of a hosiery form may be positioned, a first pair of closely spaced relatively thin hosiery guide forms conforming in shape substantially to the shape of the insert and being movable through said slot closely astride opposite sides of said nest bar, a second pair of guide forms corresponding in shape substantially to the shape of the first pair of guide forms and normally straddling and coinciding with the first pair of guide forms, means for moving the

guide forms downwardly in unison from a position astride said hosiery insert to a position adjacent one end of the hosiery insert to expose said hosiery insert, means for raising said guide forms back to the original position astride the insert, means automatically operable in the course of upward movement of the guide forms for moving the second pair of guide forms outwardly with respect to the first pair of guide forms whereby a first hose of a pair may be inserted over the first guide forms and the insert, means normally urging the second pair of guide forms into parallel alinement with the first pair of guide forms, means for releasing the second pair of guide forms whereby they will move into alinement with the first pair of guide forms and whereby a second hose of said pair may be drawn over the second pair of guide forms and the insert simultaneously so that, with subsequent downward movement of the guide forms, the guide forms are withdrawn from the hose and the hose with the insert therein may then be removed from the nest bar.

8. Apparatus for drawing a pair of hose onto an elongated relatively thin insert comprising a first pair of guide forms conforming in shape substantially to the shape of the insert, a second pair of guide forms also conforming in shape substantially to the first pair of guide forms, means to support one end of said insert adjacent corresponding ends of the first and second pairs of guide forms, means to move the first pair of guide forms astride and into position parallel to and coinciding with the insert whereby a first hose of a pair may be drawn over the first pair of guide forms and the insert, a carriage to which the first pair of guide forms is secured, means pivotally connecting the second pair of guide forms to the carriage, means to position the second pair of guide forms in side-by-side relationship with the first pair of guide forms astride the hose positioned on the first pair of guide forms comprising means resiliently urging the second pair of guide forms into parallel alinement with the first pair of guide forms, a latch pivotally mounted on at least one of the guide forms in the second pair, means rigidly interconnecting the two guide forms of the second pair, means limiting movement of the latch in one direction relative to the corresponding guide form of the second pair, a manually releasable spring-pressed detent normally disposed in the plane of the latch whereby movement of said guide forms toward and astride the insert will cause the latch to engage the detent and thereby swing the second pair of guide forms outwardly and releasing of the latch from engagement with the detent will permit the second pair of guide forms to move into parallel alinement with the first pair of guide forms whereby a second hose may be drawn over the second pair of guide forms, and means for withdrawing the guide forms from the hose so the hose are supported solely on the insert and, upon movement of the guide forms away from the insert, said latch will swing as it engages the detent and will thereby move past the detent without imparting pivotal movement to the second pair of guide forms relative to the first pair of guide forms.

9. Apparatus for drawing a pair of hose onto an elongated relatively thin insert comprising a substantially vertically movable carriage, a first pair of closely spaced guide forms carried by the carriage and conforming in shape substantially to the shape of the insert, a second pair of guide forms movably mounted on said carriage and also conforming in shape substantially to the first pair of guide forms, stationary means to support one end of said insert adjacent and between corresponding ends of the first and second pair of guide forms, means to raise and lower the carriage to move the first pair of guide forms into position parallel to and coinciding with the insert after the carriage is raised, means to move the second pair of guide forms from a position coinciding with the first guide forms to one side of the first pair

of guide forms as the carriage is raised so a first hose of a pair may be drawn over the first pair of guide forms and the insert, means to then move the second pair of guide forms from said position to one side of the first pair of guide forms to a position in side-by-side relationship with the first pair of guide forms and astride the hose positioned on the first pair of guide forms whereby a second hose may be drawn over the second pair of guide forms, and whereby lowering the carriage will withdraw the guide forms from the hose so the hose are then supported solely on the insert, said means for raising and lowering the carriage comprising a double-acting cylinder supported in fixed relation to said stationary means and extending in substantially parallel relation to the longitudinal axis of the insert supported by said stationary means, a piston in said cylinder, a piston rod connected to said piston and extending outwardly from the lower end of said cylinder remote from the stationary means, means to alternately introduce fluid pressure into opposite ends of the cylinder, a cuff member fixed to said piston rod and extending radially therefrom, a plunger fixed to said cuff member and extending upwardly therefrom, and means connecting the upper end of the plunger to said carriage whereby movement of said piston in either direction within said cylinder imparts corresponding movement to said carriage.

10. Apparatus for drawing a pair of hose onto an elongated relatively thin insert comprising a rigidly supported relatively thin nest bar, a pair of inwardly biased leaf spring clamping members carried by the nest bar for clamping one end portion of said insert therebetween, a first pair of elongated, closely spaced guide forms conforming in shape substantially to the shape of the insert and normally positioned with corresponding ends thereof disposed astride and in close proximity to the nest bar, a carriage, means fixedly connecting the other ends of the first pair of guide forms to said carriage, means supporting said carriage for movement toward and away from, and substantially parallel to the longitudinal axis of, an insert clamped between said clamping members comprising a double-acting cylinder supported in fixed relation to the clamping members and the nest bar and extending in substantially parallel relation to the latter insert, a piston in said cylinder, a piston rod connected to said piston and extending outwardly from the end of said cylinder remote from the nest bar, a cuff member fixed to said piston rod and extending radially therefrom, a plunger fixed to said cuff member and extending in substantially parallel relation to said cylinder, means connecting the end of the plunger adjacent the nest bar to said carriage whereby movement of said piston in either direction within said cylinder imparts corresponding movement to said carriage, each of the guide forms in the first pair having a longitudinally extending slot therein for accommodating the corresponding clamping member, a second pair of guide forms also conforming in shape substantially to the shape of the insert, means pivotally connecting corresponding ends of said second guide forms to said carriage, means resiliently urging said second pair of guide forms into parallel coinciding relation with, and astride, the first pair of guide forms, means automatically operable in the course of movement of the first pair of guide forms to a position coinciding with the insert for swinging the second pair of guide forms out of coinciding relation with the first pair of guide forms to facilitate the drawing of a first hose of said pair onto the first pair of guide forms and the insert, means for releasing the second pair of guide forms whereby the resilient means will move the same into position coinciding with the first pair of guide forms to facilitate the drawing of a second hose of said pair onto the second pair of guide forms whereby said means for moving the carriage toward and away from the carriage may be operated to withdraw the guide forms from the hose so the hose are then supported solely by the insert.

11

11. Apparatus for inserting elongated flat and relatively thin inserts in pairs of hose comprising a substantially horizontal base having a slot therein, a nest bar extending over said slot and having a pair of clamping members fixed thereto between which the lower end of a hosiery form may be positioned, a first pair of closely spaced relatively thin hosiery guide forms conforming in shape substantially to the shape of the insert and being movable through said slot closely astride opposite sides of said nest bar, a second pair of guide forms corresponding in shape substantially to the shape of the first pair of guide forms and normally straddling and coinciding with the first pair of guide forms, means for moving the guide forms downwardly in unison from a position astride said hosiery insert to a position adjacent one end of the hosiery insert to expose said hosiery insert, means for raising said guide forms back to the original position astride the insert, means normally urging the second pair of guide forms into parallel alinement with the first pair of guide forms, means automatically operable in the course of upward movement of the guide forms for moving the second pair of guide forms outwardly with respect to the first pair of guide forms whereby a first hose of a pair may be inserted over the first guide forms and the insert, said last-mentioned means comprising a latch pivotally mounted on at least one of the guide forms in the second pair, means pivotally supporting the second pair of guide forms for movement with the first pair of guide forms, means rigidly interconnecting the two guide forms of the second pair, means limiting downward movement of the latch relative to the corresponding guide form of the second pair, a manually releasable spring-pressed detent normally disposed in the vertical plane of the latch whereby upward movement of said guide forms will cause the latch to engage the detent and thereby swing the second pair of guide forms outwardly, and releasing of the latch from engagement with the detent will permit the second pair of guide forms to move into parallel alinement with the first pair of guide forms so a second hose of said pair may be drawn over the second pair of guide forms and the insert simultaneously and whereby, upon subsequent downward movement of the guide forms, the guide forms are withdrawn from the hose and said latch will swing upwardly as it engages the detent and will thereby move past the detent without imparting pivotal movement to the second pair of guide forms relative to the first pair of guide forms.

12. Apparatus for drawing a pair of hose onto an elongated relatively thin insert comprising a stationary substantially horizontal support for supporting one end of said insert, a substantially vertically movable plunger disposed beneath said support, a first pair of closely spaced substantially parallel guide forms fixedly connected to the upper end of said plunger and being movable astride and in close proximity to said support and the insert with vertical movement of said plunger, a second pair of guide forms, means pivotally supporting the second pair of guide forms for movement with the first pair of guide forms, said second pair of guide forms

12

being spaced apart to straddle the first pair of guide forms, all of said guide forms conforming in shape substantially to the shape of the insert, whereby after an insert is positioned upon said support, the first pair of guide forms may be raised with said plunger, a first hose of a pair may be drawn over the first pair of guide forms and the insert, the second pair of guide forms may be swung from a position to one side of the first pair of guide forms to a position in parallel side-by-side relationship with the first pair of guide forms, and a second hose may be drawn over the second pair of guide forms, after which the plunger and the first and second pairs of guide forms may be lowered to withdraw the guide forms from the hose, whereby the pair of hose are then supported solely on the insert.

13. A structure according to claim 12 wherein the support for the insert is in the form of a relatively thin bar, a pair of clamp members fixed to opposed sides of said bar and being biased toward each other for clamping a portion of the insert therebetween as it rests upon said bar, and each guide form in the first pair having a longitudinal slot therein in which said clamp members are disposed to thereby permit raising and lowering of the first pair of guide forms relative to the bar and the clamp members.

14. A method of drawing pairs of stockings onto corresponding inserts which includes the steps of positioning an insert between and in substantially coinciding relation to a first pair of insert guides, drawing the first stocking of a pair of stockings onto the first pair of guides and over the insert, positioning a second pair of insert guides astride the first stocking on the first pair of insert guides and in parallel substantially coinciding relationship with the first pair of insert guides, and drawing the second stocking of a pair of stockings onto the second pair of guides and over the first stocking, the first pair of guides and the insert.

15. Apparatus for drawing a pair of hose onto a thin elongated insert comprising a first pair of closely spaced substantially parallel guide forms adapted to receive an insert therebetween, means for supporting the insert between said first pair of parallel guide forms in substantially coinciding relation therewith, a second pair of guide forms spaced further apart than the first pair of guide forms and adapted to be positioned astride and in substantially parallel coinciding relation to the first pair of guide forms, and means for effecting relative movement between the first pair of guide forms and the second pair of guide forms whereby said first and second pairs of guide forms may be moved into and out of parallel side by side relation with the second pair of guide forms astraddle the first pair of guide forms.

References Cited in the file of this patent

UNITED STATES PATENTS

1,931,301	Struve	Oct. 17, 1933
2,007,621	Struve	July 9, 1935
2,696,295	Berry	Dec. 7, 1954