

(19) **DANMARK**

(10) **DK/EP 2587838 T3**



(12) **Oversættelse af  
europæisk patentskrift**

Patent- og  
Varemærkestyrelsen

- 
- (51) Int.Cl.: **H 04 R 25/00 (2006.01)**
- (45) Oversættelsen bekendtgjort den: **2018-05-28**
- (80) Dato for Den Europæiske Patentmyndigheds bekendtgørelse om meddelelse af patentet: **2018-03-07**
- (86) Europæisk ansøgning nr.: **11186420.3**
- (86) Europæisk indleveringsdag: **2011-10-25**
- (87) Den europæiske ansøgnings publiceringsdag: **2013-05-01**
- (84) Designerede stater: **AL AT BE BG CH CY CZ DE DK EE ES FI FR GB GR HR HU IE IS IT LI LT LU LV MC MK MT NL NO PL PT RO RS SE SI SK SM TR**
- (73) Patenthaver: **Oticon A/S, Kongebakken 9, 2765 Smørum, Danmark**
- (72) Opfinder: **Karlsen, Morten Friis, Oticon A/S, c/o Kongebakken 9, 2765 Smørum, Danmark**
- (74) Fuldmægtig i Danmark: **Oticon A/S, Kongebakken 9, 2765 Smørum, Danmark**
- (54) Benævnelse: **Høreapparat holdertilbehør**
- (56) Fremdragne publikationer:  
**WO-A1-2004/112431**  
**WO-A2-2009/083007**  
**DE-C1- 10 048 337**



# DESCRIPTION

## BACKGROUND OF THE INVENTION

**[0001]** The invention is related to a hearing aid retainer accessory for retaining a BTE (behind-the-ear) hearing aid at a user's ear.

**[0002]** In order to operate at best and to prevent damage resulting from falling of the ear and dropping to the ground, a BTE-hearing aid has to be kept in a safe position at a user's ear. Also if the user's head moves intensely such as it may do by doing sport. Another example is a child playing.

**[0003]** US 2007/0217641 A1 discloses a hearing aid protection accessory formed by a flexible sleeve to be wrapped around a housing of a hearing aid, the flexible sleeve to be connected to a users clothing via a clip and a cord. Suitable for preventing the hearing aid from dropping to the ground this arrangement, however, does not allow an adjustment to a user's ear and is likely to entangle with all kinds of obstacles a child may encounter playing. Also the sleeve adds to the thickness of the hearing aid housing rendering it difficult to be placed behind a small ear.

**[0004]** US 4,881,616 and US 4,702,345 each disclose a hearing aid retainer accessory that is formed by a tube with a respective sleeve connected to each end, both sleeves pulled over the housing of the hearing aid. The arrangement disclosed in US 4,881,616 allows an adjustment to a user ear by moving the sleeves toward or away from each other on the housing of the hearing aid. The degree of adjustment, however, is limited by the longitudinal dimension of the hearing aid housing. The sleeves of both US 4,881,616 and US 4,702,345 add to the thickness of the hearing aid housing, resulting in a discomfort to wear or even the ears protruding, provided they are still in a process of growth. Furthermore, the sleeves are likely to interfere with a control button located at the surface of the hearing aid housing.

**[0005]** US 7,013,018 B2 discloses an adjustable earring for a headset, the earring being connected via a pivotal link to a housing of a speaker included in the headset.

**[0006]** Finally, US 4,918,757 and US 3,327,807 each disclose an arrangement for retaining a hearing aid at a user's head utilizing a head band. Undesirably each of the arrangements exerts an uncomfortable force to the users head and is rather noticeable.

**[0007]** DE10048337 relates to a hearing aid device comprising a housing and a carrier hook for supporting the housing behind the ear. The opposite end of the housing to the carrier hook is provided with a fixed or releasable retaining element that cooperates with an otoplastic worn within the ear. The retaining element may incorporate an electrical cable and/or a sound channel.

**[0008]** WO2004112431 concerns an electrical and mechanical connection between a head worn communication device and an accessory thereto. Mechanical connection means and electrical connection points at the communication device are placed at one and the same surface part, and further connection means and electrical connection points at the accessory are placed at one and the same surface part, such that a sliding action between the two surface parts will cause the respective mechanical connection means to grip each other while the respective electrical connection points gain contact with each other. The document further relates to a hearing aid with an accessory.

**[0009]** WO2009083007 relates to a hearing instrument with a housing that is adapted for positioning in the ear canal of a user without obstructing the ear canal of the user. The housing accommodates a signal processor for generating an audio signal, and a receiver that is connected to an output of the signal processor for converting the processed compensated audio signal into a sound signal, wherein the housing has a trunk part that is interconnected with a tip part. The housing further accommodates a printed circuit board with the signal processor forming a wall within the housing extending transversely to the longitudinal extension of the trunk part.

**[0010]** It is therefore an object of the present invention to provide a hearing aid retainer accessory which avoids the disadvantages of prior art devices and is intuitive and easy to attach, comfortable to wear, free of interference with a hearing aid's control buttons and the specially designed hearing aid geometry, all while retaining a hearing aid at a user's ear safely and stably.

A hearing aid in the scope of the present invention is a BTE-hearing aid or a BTE-like-hearing aid.

## **SUMMARY OF THE INVENTION**

**[0011]** According to a first aspect of the present invention the technical object is achieved by a hearing aid retainer accessory according to the subject-matter of claim 1. Engageable or engaged to a hearing aid via a battery drawer, the hearing aid retainer accessory is free of interference with a hearing aid's control buttons and the specially designed hearing aid geometry. Furthermore, the hearing aid retainer accessory is very intuitive and easy to attach to a hearing aid.

The first mechanical connection means can be shaped as a hook-like protrusion. The hook-like protrusion can be fitted to a complementary cut-out region embodied by a mechanical connection terminal of a longitudinal end face portion of hearing aid's housing. When said first mechanical connection means is connected to said mechanical connection terminal, the hook-like protrusion is accommodated in the cut-out region, providing a very stable mechanical connection.

**[0012]** In a further embodiment the first and the second end face portion comprise a

respective first and second electrical connection means electrically connected to each other. The first electrical connection means is configured to engage an electrical connection point of a longitudinal end face portion of a hearing aid's housing. The second electrical connection means is configured to engage an electrical connector of accessory component's connector portion. In this way an electric/electronic accessory component like an FM-transmitter can be electrically connected to a hearing aid indirectly, once a hearing aid's electrical connection point is occupied by the first electrical connection means of the hearing aid retainer accessory. The first and/or second electrical connection means can be configured as connection points to allow a very reliable electrical connection.

**[0013]** In a preferred embodiment the first end face portion has a surface area of roughly the same size as a longitudinal end face portion of a hearing aid's housing. The first end face portion can have a surface area of roughly the same size as an accessory component's connector portion. The first and the second end face portion can have a surface area of roughly the same size. By tailoring the first and second end face portion such, a nearly seamless shape between a hearing aid's and/or an accessory component's housing and the hearing aid retainer accessory can be achieved once they are connected.

To provide ergonomic shape when worn, the first and the second end face portion can face away from each other.

According to a second aspect of the present invention the technical object is achieved by a hearing aid accessory unit according to the subject-matter of claim 7. In a preferred embodiment the first and the second end face portion comprise a respective first and second electrical connection means electrically connected to each other. The first electrical connection means is configured to engage to an electrical connection point of a longitudinal end face portion of a hearing aid's housing. The second electrical connection means is engaged to an electrical connector comprised by the accessory component's connector portion. The first electrical connection means and the second electrical connection means can be provided as connection points.

The first mechanical connection means and the mechanical connector can be identically shaped as a hook-like protrusion fitted to a cut-out region embodying the second mechanical connection means. The first and the second end face portion can face away from each other. The first and the second end face portion can have a surface area of roughly the same size as the connector portion.

**[0014]** According to a third aspect of the present invention the technical object is achieved by a hearing aid assembly according to the subject-matter of claim 11. In a preferred embodiment the first and the second end face portion comprise a respective first and second electrical connection means electrically connected to each other. The first electrical connection means is engaged to the electrical connection point. The second electrical connection means is engaged to an electrical connector comprised by the accessory component's connector portion. The accessory component can thus be supplied with electrical energy/signals from the hearing aid or can supply electrical energy/signals to the hearing aid. The first electrical connection means and the second electrical connection means can be provided as connection points.

**[0015]** The first mechanical connection means and the mechanical connector can be identically shaped as a hook-like protrusion fitted to a cut-out region embodying the second mechanical connection means and the mechanical connection terminal. This provides for a sturdy mechanical connection throughout the hearing aid assembly.

**[0016]** In order to be worn ergonomically the first and the second end face portion can face away from each other. The first and the second end face portion can have a surface area of roughly the same size as the connector portion and/or the longitudinal end face portion. This provides for the hearing aid's assembly to have a seamless outer surface and hence a high comfort in wear.

### **BRIEF DESCRIPTION OF THE DRAWINGS**

#### **[0017]**

Fig. 1

schematically depicts a side view of a hearing aid retainer accessory according to the invention;

Fig. 2

shows a perspective view of the arrangement of fig. 1;

Fig. 3

schematically depicts a side view of another embodiment of a hearing aid retainer accessory;

Fig. 4

shows a perspective view of the arrangement of fig. 3;

Fig. 5

schematically depicts a detail of a hearing aid retainer accessory's first end face portion and an accessory component's connector portion;

Fig. 6

schematically depicts a side view of a hearing aid retainer accessory about to engage to a hearing aid, where parts of the hearing aid housing are cut away to show internal structures;

Fig. 7

schematically depicts a hearing aid retainer accessory according to a further embodiment of the current invention;

### **DETAILED DESCRIPTION**

**[0018]** Fig.1 shows a hearing aid 20, a hearing aid retainer accessory 10 and an accessory component 30. The hearing aid 20 is designed as a BTE hearing aid with a housing 21 having

a longitudinal end face portion 22. The longitudinal end face portion 22 comprises a mechanical connection terminal 23 and an electrical connection point 24.

The hearing aid retainer accessory 10 comprises a retainer element 11 with a firm hook-like shape. The retainer element 11 has a first end face portion 12 with a first mechanical connection means 13 having a hook-like protrusion being engageable to a mechanical connection terminal 23, which is designed as a cut-out region (to be seen best in fig. 2), of a longitudinal end face portion 22.

**[0019]** Furthermore, the retainer element 11 comprises a second end face portion 16 having a second mechanical connection means 17 shaped as cut-out region complementary to the first mechanical connection means 13 (to be seen best in fig. 2) The first mechanical connection means 13 and the mechanical connector 33 are identically shaped as a hook-like protrusion fitted to a cut-out region embodying the second mechanical connection means 17. Hence, said second mechanical connection means 17 is engageable to said mechanical connector 33, while also being connectable to the mechanical connection terminal 23.

The first and the second end face portion 12, 16 comprise a respective first and second electrical connection means 14, 18 electrically connected to each other. The first electrical connection means 14 is configured as connection points to engage to an electrical connection point 24 of a longitudinal end face portion 22 of a hearing aid's 20 housing 21, the second electrical connection means 18 is configured as connection points being configured to engage to an electrical connector 34 of accessory component's 30 connector portion 32. The first and the second end face portion 12, 16 faces away from each other and have a surface area of roughly the same size. Furthermore, the first end face portion 12 has a surface area of roughly the same size as the longitudinal end face portion 22 of the hearing aid's 20 housing 21 and the same size as the accessory component's 30 connector portion 32.

To form a hearing aid accessory unit 40 modularly, the accessory component 30 is connected to the hearing aid retainer accessory 10 by a sliding on motion (indicated by direction arrow next to the mechanical connector 33). If connected, the mechanical connector 33 is engaged to the second mechanical connection means 17 and the electrical connector 34 is connected to the second electrical connection means 18. Since the first and second electrical connection means 14, 18 are electrically connected to each other, and electrical connector 34 is connected to the second electrical connection means 18, the electrical connector 34 is also in electrical connection with the first electrical connection means 14.

**[0020]** A hearing aid assembly 100 is modularly formed by connecting the hearing aid 10, the hearing aid retainer accessory 20 and the accessory component 30 by sliding said components onto each other (indicated by direction arrow next to the mechanical connector 33 and first mechanical connection means 13). For connection, a battery drawer 25 of the hearing aid 20 is in an open position. If connected, the first mechanical connection means 13 is engaged to the mechanical connection terminal 23 and the mechanical connector 33 is engaged to the second mechanical connection means 17. Furthermore, the first electrical connection means 14 is engaged to the electrical connection point 24 and the second electrical connection means 18 is engaged to the electrical connector 34 comprised by the accessory component's 30 connector portion 32.

**[0021]** Fig. 2 shows a perspective view of the arrangement of fig. 1 to especially provide a better understanding of the second mechanical connection means 17 and the mechanical connection terminal 23, both being configured as a cut-out region being complementary to the first mechanical connection means 13 and the mechanical connector 33 described with respect to fig. 1. The connection point 24 is configured as connection points being placed on the same surface, namely the longitudinal end face portion 22, as the mechanical connection terminal 23. The second electrical connection means 18 are configured as connection points placed on the same surface, namely the second end face portion 15, as the second mechanical connection means 17.

A hearing aid retainer accessory 10 in fig. 3 comprises a retainer element 11 with a firm and hook-like shape having a first end face portion 12 with a first mechanical connection means 13 configured as a hook-like protrusion to be engageable to a mechanical connection terminal 23, which is designed as a cut-out region (to be seen best in fig. 4) of a longitudinal end face portion 22 of a housing 21 of a hearing aid 20. The first end face portion 12 has a surface area of roughly the same size as the longitudinal end face portion 22 of the hearing aid's 20 housing 21.

**[0022]** A hearing aid assembly 100 is modularly formed by connecting the hearing aid 20 and the hearing aid retainer accessory 10 sliding said components onto each other (indicated by direction arrow next to the first mechanical connection means 13). To establish a connection, a battery drawer 25 of the hearing aid 20 is in an open position. If connected, the first mechanical connection means 13 is engaged to the mechanical connection terminal 23.

Fig. 4 shows a perspective view of the arrangement of fig. 3 to especially provide a better understanding of the mechanical connection terminal 23 being configured as a cut-out region being complementary to the first mechanical connection means 13 described with respect to fig. 3. The connection point 24 is configured as connection points being placed on the same surface, namely the longitudinal end face portion 22, as the mechanical connection terminal 23. In this embodiment the no electrical connection between the hearing aid retainer accessory 10 and the hearing aid 20 is established.

Fig. 5 schematically depicts a detailed view representing both the first end face portion 12 of the hearing aid retainer accessory 10 from fig. 1 and fig. 2 and the connector portion 32 of the accessory component 30 from fig. 1 and fig. 2 likewise. The first end face portion 12 comprises a first mechanical connection means 13 configured as a hook-like protrusion placed on the same surface with a comprised first electrical connection means 14 configured as connection points. Likewise the connector portion 32 comprises a mechanical connector 33 configured as a hook-like protrusion placed on the same surface with a comprised an electrical connector 34 configured as connection points.

In fig. 6 a hearing aid retainer accessory's 10 is about to be engaged to a hearing aid 20. The descriptions with respect to fig. 1 and fig. 2 apply accordingly.

A hearing aid retainer accessory 10 in fig. 7 comprises a retainer element 11 having a firm and hook-like shape and comprising a first end face portion 12 with first mechanical connection means 13 configured to be engageable to a mechanical connection terminal 23 of a longitudinal end face portion 22 of a housing 21 of a hearing aid 20. The first mechanical

connection means 13 is shaped as a male euro-pin connector. The mechanical connection terminal 23 on the other hand is provided as a female euro-pin connector. Since only a mechanical connection between the hearing aid 20 and the aid retainer accessory 10 is required, the first mechanical connection means 13 is electrically nonconducting.

A hearing aid assembly 100 is modularly formed by mechanically connecting the hearing aid 10 and the hearing aid retainer accessory 20 pushing said components onto each other. The male euro-pin connector protruding from first end face portion 12 is engaged with the female euro-pin connector located in the longitudinal end face portion 22.

The first end face portion 12 has a surface area of roughly the same size as the longitudinal end face portion 22 of the hearing aid's 20 housing 21.

## **REFERENCES CITED IN THE DESCRIPTION**

This list of references cited by the applicant is for the reader's convenience only. It does not form part of the European patent document. Even though great care has been taken in compiling the references, errors or omissions cannot be excluded and the EPO disclaims all liability in this regard.

### **Patent documents cited in the description**

- [US20070217641A1 \[0003\]](#)
- [US4881616A \[0004\] \[0004\] \[0004\]](#)
- [US4702345A \[0004\] \[0004\]](#)
- [US7013018B2 \[0005\]](#)
- [US4918757A \[0006\]](#)
- [US3327807A \[0006\]](#)
- [DE10048337 \[0007\]](#)
- [WO2004112431A \[0008\]](#)
- [WO2009083007A \[0009\]](#)

## Patentkrav

1. Høreapparatholdertilbehør (10) til anvendelse med et høreapparat (20), der har et hus (21) med en langsgående endefladedel (22), der omfatter en mekanisk forbindelsestilslutning (23) og et elektrisk forbindelsespunkt (24),  
5 hvor høreapparatholdertilbehøret (10) omfatter et holderelement (11) med en første endefladedel (12), der har et første mekanisk forbindelsesmiddel (13), som er konfigureret til at indgribe med den mekaniske forbindelsestilslutning (23) af den langsgående endefladedel (22) af huset (21) af høreapparatet (20),  
10 hvor holderelementet (11) omfatter en anden endefladedel (16), der har et andet mekanisk forbindelsesmiddel (17), som er konfigureret til at indgribe med en mekanisk forbindelsesklemme (33) af en tilbehørskomponents (30) forbindelsesklemmedel (32); kendetegnet ved, at det andet mekaniske forbindelsesmiddel (17) er dannet som et udskæringsområde, der er komplementært til det første mekaniske forbindelsesmiddel (13), så at  
15 udskæringsområdet er indrettet til at passe med den mekaniske forbindelsesklemme (33), som er formet som et krog lignende fremspring.
2. Høreapparatholdertilbehør (10) ifølge krav 1, kendetegnet ved, at det første mekaniske forbindelsesmiddel (13) er formet som et krog lignende fremspring,  
20 der er indrettet til at passe med et udskæringsområde, der indbefatter den mekaniske forbindelsestilslutning (23) af den langsgående endefladedel (22) af høreapparatets (20) hus (21).
3. Høreapparatholdertilbehør (10) ifølge krav 1, kendetegnet ved, at de første og de andre endefladedele (12, 16) omfatter et respektive første og andet elektrisk forbindelsesmiddel (14, 18), der er elektrisk forbundet til hinanden, hvor det første elektriske forbindelsesmiddel (14) er konfigureret til at indgribe med det elektriske forbindelsespunkt (24) af den langsgående endefladedel (22) af høreapparatets (20) hus (21), hvor det andet elektriske  
30 forbindelsesmiddel (18) er konfigureret til at indgribe med en elektrisk forbindelsesklemme (34) af tilbehørskomponentens (30) forbindelsesklemmedel (32).
4. Høreapparatholdertilbehør (10) ifølge hvilke som helst af kravene 1 til 3, kendetegnet ved, at den første endefladedel (12) har et overfladeområde, som har den samme størrelse som den langsgående endefladedel (22) af høreapparatets (20) hus (21).  
35

- 5 5. Høreapparatholdertilbehør (10) ifølge hvilke som helst af kravene 1 til 4, kendetegnet ved, at den første endefladedel (12) har et overfladeområde, der har den samme størrelse som tilbehørskomponentens (30) forbindelsesklemmedel (32).
- 10 6. Høreapparatholdertilbehør (10) ifølge hvilke som helst af kravene 3 til 4, kendetegnet ved, at den første og den anden endefladedel (11, 16) vender bort fra hinanden og har et overfladeområde med den samme størrelse.
- 15 7. Høreapparattilbehørsenhed (40), som er modulært dannet af et høreapparatholdertilbehør (10), der omfatter et holderelement (11) med en første og en anden endefladedel (12, 16), der har et respektive første og andet mekanisk forbindelsesmiddel (13, 17), hvor det første mekaniske forbindelsesmiddel (13) er konfigureret til at indgribe med en mekanisk forbindelsestilslutning (23) af en langsgående endefladedel (22), der omfatter et elektrisk forbindelsespunkt (24) af et høreapparats (20) hus (21), og af en tilbehørskomponent (30), der har en forbindelsesklemmedel (32) med en mekanisk forbindelsesklemme (33), som er konfigureret til at indgribe med det 20 andet mekaniske forbindelsesmiddel (17), kendetegnet ved, at det andet mekaniske forbindelsesmiddel (17) er dannet som et udskæringsområde, der er komplementært til det første mekaniske forbindelsesmiddel (13), så at udskæringsområdet er indrettet til at passe med den mekaniske forbindelsesklemme (33), som er formet som et krog lignende fremspring.
- 25 8. Høreapparattilbehørsenhed (40) ifølge krav 7, kendetegnet ved, at de første og de andre endefladedele (12, 16) omfatter et respektive første og andet elektrisk forbindelsesmiddel (14, 18), der er elektrisk forbundet til hinanden, hvor det første elektriske forbindelsesmiddel (14) er konfigureret til at indgribe med det elektriske forbindelsespunkt (24) af den langsgående endefladedel 30 (22) af høreapparatets (20) hus (21), og det andet elektriske forbindelsesmiddel (18) er konfigureret til at indgribe med en elektrisk forbindelsesklemme (34), der består af tilbehørskomponentens (30) forbindelsesklemmedel (32).
- 35 9. Høreapparattilbehørsenhed (40) ifølge krav 7 eller 8, kendetegnet ved, at det første mekaniske forbindelsesmiddel (13) er formet som et krog lignende

fremspring, der er indrettet til at passe med et udskæringsområde, der indbefatter den anden mekaniske forbindelsestilslutning (23).

5 10. Høreapparattilbehørsenhed (40) ifølge hvilke som helst af kravene 7 til 9, kendetegnet ved, at de første og de andre endefladedele (12, 16) vender bort fra hinanden og har et overfladeområde med den samme størrelse som forbindelsesklemmedelen (32) og den langsgående endefladedel (22).

10 11. Høreapparatanordning (100), som er modulært dannet af et høreapparat (20), der har et hus (21) med en langsgående endefladedel (22), der omfatter en mekanisk forbindelsestilslutning (23) og et elektrisk forbindelsespunkt (24) af et høreapparat holdertilbehør (10), der omfatter et holderelement (11) med en første og en anden endefladedel (12, 16), der har et respektive første og  
15 andet mekanisk forbindelsesmiddel (13, 17), hvor det første mekaniske forbindelsesmiddel (13) er konfigureret til at indgribe med den mekaniske forbindelsestilslutning (23), og af en tilbehørskomponent (30), der har en forbindelsesklemmedel (32) med en mekanisk forbindelsesklemme (33), som er konfigureret til at indgribe med det andet mekaniske forbindelsesmiddel (17), kendetegnet ved, at det andet mekaniske forbindelsesmiddel (17) er  
20 dannet som et udskæringsområde, der er komplementært til det første mekaniske forbindelsesmiddel (13), så at udskæringsområdet er indrettet til at passe med den mekaniske forbindelsesklemme (33), som er formet som et krog lignende fremspring.

25 12. Høreapparatanordning (100) ifølge krav 11, kendetegnet ved, at de første og de andre endefladedele (12, 16) omfatter et respektive første og andet elektrisk forbindelsesmiddel (14, 18), der er elektrisk forbundet til hinanden, hvor det første elektriske forbindelsesmiddel (14) er konfigureret til at indgribe med det elektriske forbindelsespunkt (24), og det andet elektriske  
30 forbindelsesmiddel (18) er konfigureret til at indgribe med en elektrisk forbindelsesklemme (34), der består af tilbehørskomponentens (30) forbindelsesklemmedel (32).

35 13. Høreapparatanordning (100) ifølge krav 11 eller 12, kendetegnet ved, at det første mekaniske forbindelsesmiddel (13) er formet som et krog lignende fremspring, der er indrettet til at passe med et udskæringsområde, der indbefatter den mekaniske forbindelsestilslutning (23).

14. Høreapparatordning (100) ifølge hvilke som helst af kravene 11 til 13, kendetegnet ved, at de første og de andre endefladedele (12, 16) vender bort fra hinanden og har et overfladeområde med den samme størrelse som forbindelsesklemmedelen (32) og den langsgående endefladedel (22).

5

10

# DRAWINGS

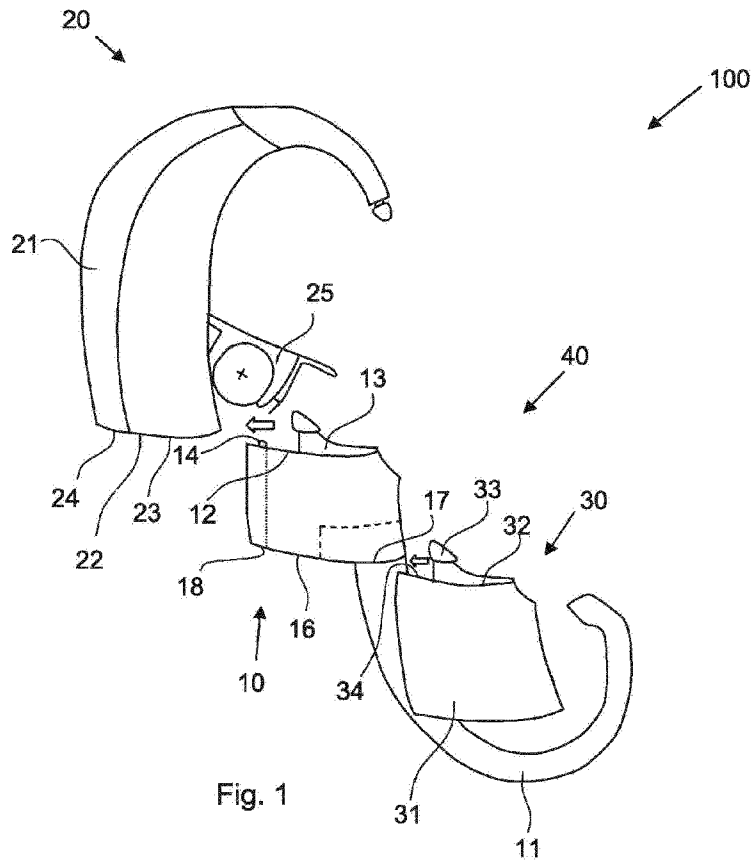

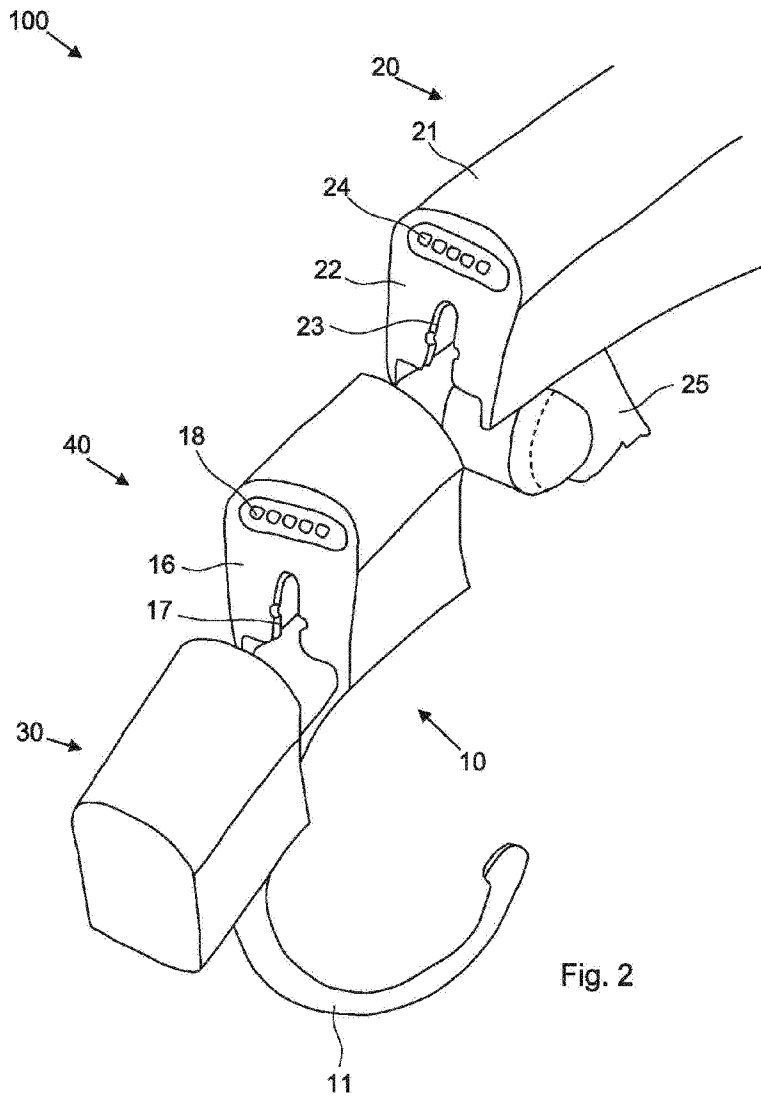

Fig. 2

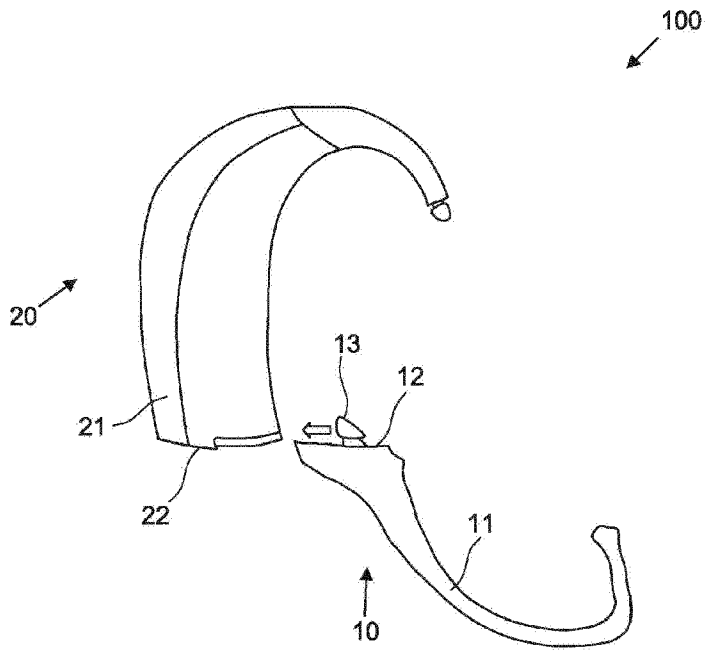

Fig. 3

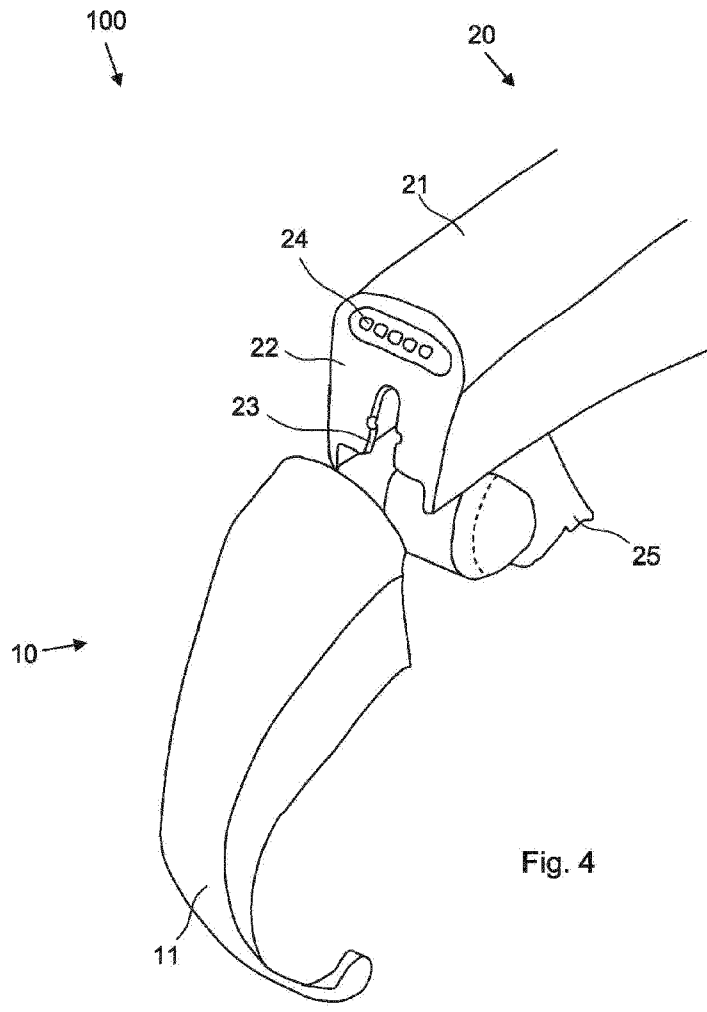

Fig. 4

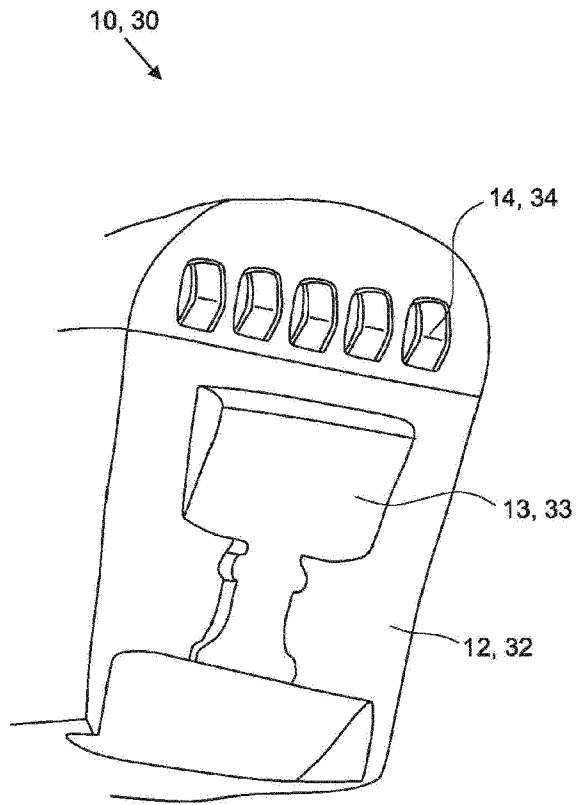

Fig. 5

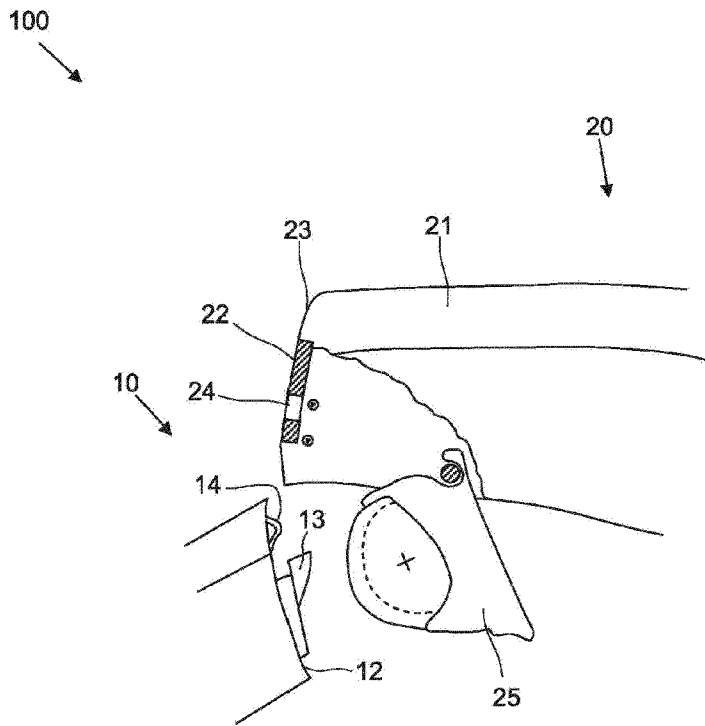

Fig. 6

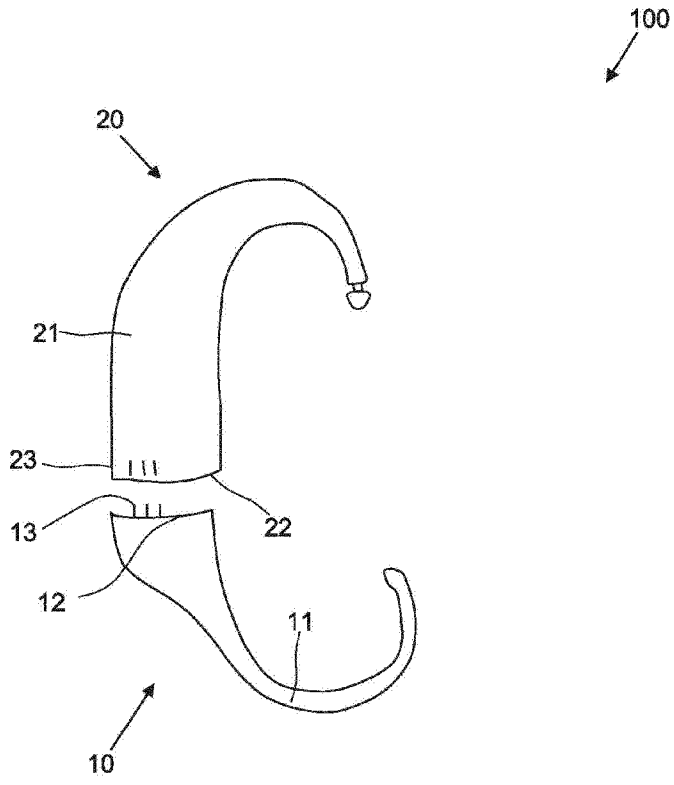

Fig. 7