

July 14, 1964

W. H. BENNER ETAL

3,141,108

LIGHTNING ARRESTER WITH AN ARC-EXTINGUISHING GAS

Filed Dec. 26, 1961

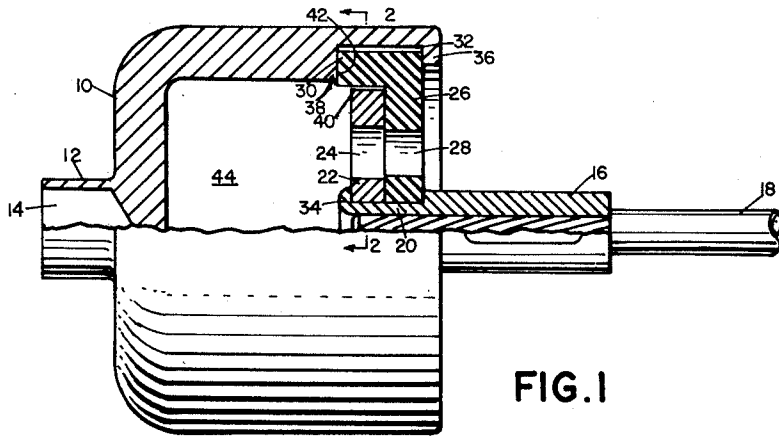

FIG. 1

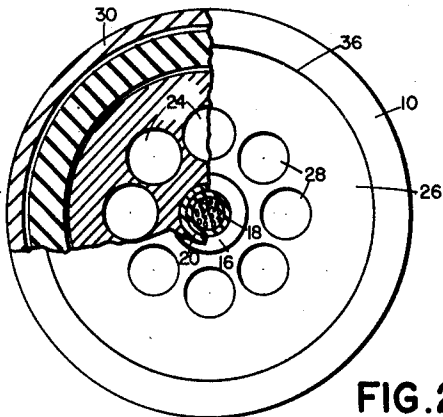

FIG. 2

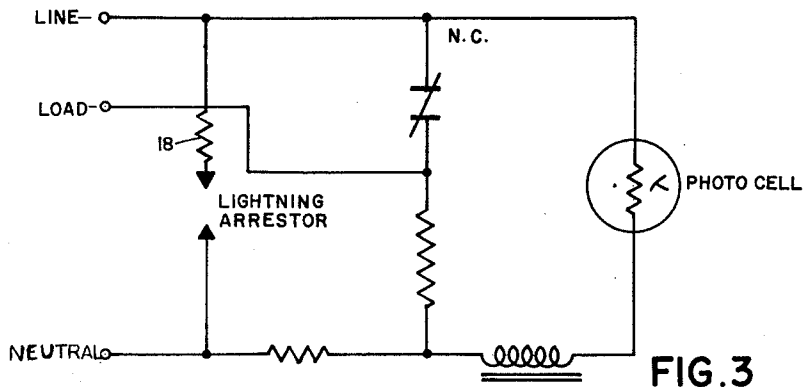

FIG. 3

INVENTORS:  
WINFIELD H. BENNER.  
JAMES M. WHALL  
BY *Moses, Rolke & Rolke*  
ATTORNEYS.

1

2

3,141,108

## LIGHTNING ARRESTER WITH AN ARC-EXTINGUISHING GAS

Winfield H. Benner, Westwood, and James M. Whall, Abington, Mass., assignors to Sigma Instruments, Inc., Braintree, Mass., a corporation of Massachusetts

Filed Dec. 26, 1961, Ser. No. 161,807

7 Claims. (Cl. 313-231)

This invention relates to lightning arresters designed for protection of sensitive auxiliary equipment such as photo-electric controls, meters, relays and the like. It is particularly suitable for use in the protection of photo-electric lighting control units, as used on light poles or in similar locations. It may be used wherever secondary equipment of the character described, requires protection against the effects of sudden very high voltage arising from lightning, switching transients or other causes.

The object of the invention is to provide an arrester of very simple construction, embodying a minimum number of parts and in which an insulating element is provided of vulcanized fiber or other non-conductive material, for example, "Delrin," of such nature that it will liberate gas in the presence of an arc caused by lightning or other excess voltage, which gas will quench the arc. Owing to the use of a minimum number of parts which can be properly fitted, the air gap of the device can be held to accurate dimensions, and particularly those dimensions governing concentricity.

Other objects and advantages of the invention will appear in the course of the description of one illustrative embodiment thereof. It will be understood that changes in arrangement and details of construction may be made without departing from the principles of the invention.

In the accompanying drawings:

FIG. 1 is a view of the lightning arrester, partly in longitudinal section and partly in side elevation.

FIG. 2 is an end view of the device, partly in transverse section on line 2-2 of FIG. 1.

FIG. 3 is a schematic diagram showing one application of the device.

Referring to the drawings in detail, the device comprises a housing 10 of metal such as brass or aluminum, which is preferably provided with an integral protuberance 12 which may be bored out, as indicated at 14 and which provides means for mounting the device in a photo-electric control or like device (not shown) for installing on an electric light pole or in whatever other location the device is to be used. This terminal protuberance 12 is connected to ground. The other terminal of the arrester comprises a metal stem 16 into which leads a conductor 18. A resistance is interposed in the current path, which is preferably of a metal having a high temperature positive coefficient of resistance whereby resistance will increase very rapidly on increase of temperature. This resistance may, in some cases, be introduced by making the lead-in wire 18 of such high temperature coefficient metal.

Mounted on the inner end of the stem 16 which is reduced in diameter, as indicated at 20, are a perforated disk 22 of a conducting metal such as copper, which has a series of holes 24 therein, and an insulator block 26 having holes 28 therein. The block 26 is provided with a flange portion 30 which extends over and slightly beyond the margin of the conducting disk 22, and which is received in a recess 32 in the housing. The block 26 is formed of an insulating material such as vulcanized fiber which, when subjected to a high temperature arc, will liberate a gas which will extinguish the arc. The ordinary vulcanized fibers of commerce and some plastic materials are suitable, such as "Delrin." The conducting disk 22

and the insulating block 26 are clamped to the stem by spinning over the end thereof, as indicated at 34. The conducting tube and insulating block assembly are secured in the housing by the mounting of the insulator block in the recess 32, in which it may be held in any suitable manner, preferably by spinning over the edge of the housing, as indicated at 36. The end of the insulator block is clamped against the shoulder 42 at the bottom of the recess 32. The spark gap, which must be broken down in the case of lightning or other very high voltage, is formed between the annular edge 40 of the conducting disk 22 and the annular edge 38 of the housing adjacent to the end of the insulator flange 30. Owing to the mounting of the insulator block in the recess in the housing, and to the fact that the disk 22 is accurately positioned with respect to the insulator block because both of these members are mounted on the stem 16, it is possible to hold the dimensions of the gap to very close tolerances, both as to length and concentricity. Air insulation only is necessary between the housing and the end of the stem. Without unduly enlarging the housing, an entirely adequate air gap is provided. Also, the chamber 44 in the interior of the housing provides ample expansion space for any gas which may be formed, excess gas issuing through the holes 24 and 28.

The lightning arresters of this type are connected across the power line from which they afford lightning surge protection to the equipment they are in and always remain so associated throughout the life of the control. Therefore they must perform as an "open circuit" to the source power and as a "short circuit" to lightning surges.

It will be seen that the construction described above embodies an absolute minimum of parts. In the example illustrated, there are a total of six parts, only four of which enter into the path of lightning discharge, namely: the conductor 18, stem 16, disk 22 and housing 10.

We claim:

1. An overload voltage arrester comprising an all-metal hollow housing open at one end, a block of insulating material mounted in the open end of the housing, a disk of conducting metal fitting against the inner surface of said block of insulating material, said block of insulating material and disk having aligning holes therethrough, a stem of conducting metal passing through said holes, said stem having formations thereon for clamping said disk and block of insulating material together and to said stem, said conducting disk being supported in definite position spaced from the surface of the housing by said block of insulating material so as to provide a spark gap of fixed dimensions between said disk and the nearest area of said housing.

2. A construction as claimed in claim 1, in which the conducting stem is supported in the housing by means of the block of insulating material in such position that there is a large space providing adequate air insulation between the end of the stem and the interior of the housing.

3. A construction as claimed in claim 1, in which the interior of the housing is vented by means of vent holes in the insulating block and conducting disk.

4. A construction as claimed in claim 1, in which the insulating block is received in a recess near the outer end of the housing and held against a shoulder at the bottom of said recess by a flanged portion at the outer end of the housing.

5. A construction as claimed in claim 1, in which the conducting stem is formed with a reduced end portion which fits in a hole in the insulating block and conducting disk, the insulating block fitting against a shoulder on the tube formed by the reduction in the diameter thereof, the end of the stem being flanged over upon the

3

conducting disk so as to lock the disk and block against said shoulder.

6. A construction as claimed in claim 1, in which the housing is formed with an integral lug on its rear end by which it may be mounted.

7. An overload voltage arrester comprising a hollow housing of conducting material open at one end, a block of insulating material mounted in the open end of said housing, said block being formed of a material which will liberate arc-extinguishing gas when exposed to an arc, a body of conducting material supported in fixed position inside of said housing by said block of insulating material, a conductor fixed to said body of said conducting material and extending out of said housing through an opening in said block of insulating material, said body of

5

10

15

4

conducting material carried by the block of insulating material being supported in spaced relationship from an interior surface of the housing adjacent to said block so as to provide a spark gap of fixed dimensions across and close to a surface of said block between said body of conducting material and said housing, and an opening into the interior of the housing for permitting exhaustion into the atmosphere of excess gas liberated by occurrence of an arc.

References Cited in the file of this patent

UNITED STATES PATENTS

2,735,954	Rawls	Feb. 21, 1956
2,829,296	Culp et al.	Apr. 1, 1958