



(43) International Publication Date
28 June 2012 (28.06.2012)

- (51) International Patent Classification:
B65D 43/16 (2006.01) *B65D 85/60* (2006.01)
- (21) International Application Number:
PCT/EP2011/073205
- (22) International Filing Date:
19 December 2011 (19.12.2011)
- (25) Filing Language: English
- (26) Publication Language: English
- (30) Priority Data:
MI2010A 002356 22 December 2010 (22.12.2010) IT
- (71) Applicant (for all designated States except US): **LUIGI ZAINI S.p.A.** [IT/IT]; Via Carlo Imbonati, 59, I-20159 Milano (IT).
- (72) Inventor; and
(75) Inventor/Applicant (for US only): **ZAINI, Luigi** [IT/IT]; Via San Bernardino, 7, I-MILANO 20122 (IT).
- (74) Agent: **RAPISARDI, Mariacristina**; Via Serbelloni, 12, I-20122 Milano (IT).
- (81) Designated States (unless otherwise indicated, for every kind of national protection available): AE, AG, AL, AM,

AO, AT, AU, AZ, BA, BB, BG, BH, BR, BW, BY, BZ, CA, CH, CL, CN, CO, CR, CU, CZ, DE, DK, DM, DO, DZ, EC, EE, EG, ES, FI, GB, GD, GE, GH, GM, GT, HN, HR, HU, ID, IL, IN, IS, JP, KE, KG, KM, KN, KP, KR, KZ, LA, LC, LK, LR, LS, LT, LU, LY, MA, MD, ME, MG, MK, MN, MW, MX, MY, MZ, NA, NG, NI, NO, NZ, OM, PE, PG, PH, PL, PT, QA, RO, RS, RU, RW, SC, SD, SE, SG, SK, SL, SM, ST, SV, SY, TH, TJ, TM, TN, TR, TT, TZ, UA, UG, US, UZ, VC, VN, ZA, ZM, ZW.

(84) Designated States (unless otherwise indicated, for every kind of regional protection available): ARIPO (BW, GH, GM, KE, LR, LS, MW, MZ, NA, RW, SD, SL, SZ, TZ, UG, ZM, ZW), Eurasian (AM, AZ, BY, KG, KZ, MD, RU, TJ, TM), European (AL, AT, BE, BG, CH, CY, CZ, DE, DK, EE, ES, FI, FR, GB, GR, HR, HU, IE, IS, IT, LT, LU, LV, MC, MK, MT, NL, NO, PL, PT, RO, RS, SE, SI, SK, SM, TR), OAPI (BF, BJ, CF, CG, CI, CM, GA, GN, GQ, GW, ML, MR, NE, SN, TD, TG).

Declarations under Rule 4.17:

— of inventorship (Rule 4.17(iv))

Published:

— with international search report (Art. 21(3))

(54) Title: CONTAINER FOR SURPRISES, PARTICULARLY FOR CHOCOLATE EGGS

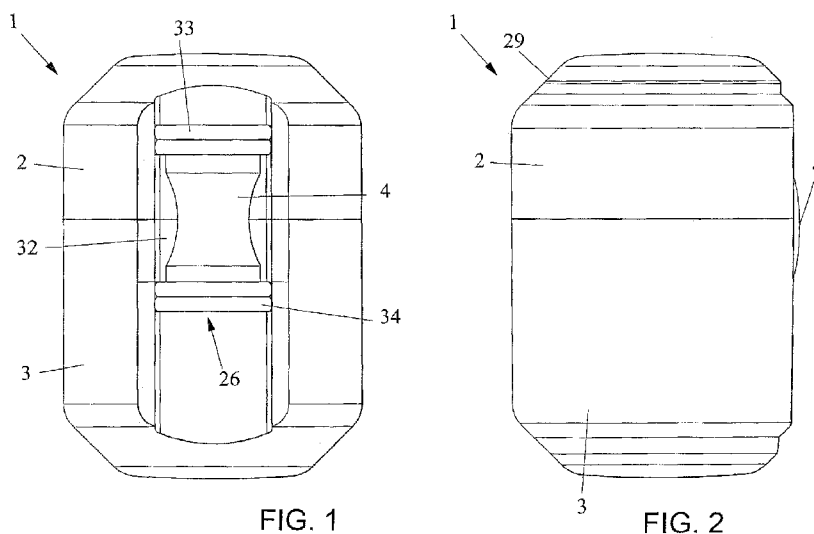

(57) Abstract: A container (1) for surprises, particularly for chocolate eggs, comprises two half-shells (2, 3) and at least one strip (4) by means of which said half-shells (2, 3) are operatively connected together between a closed configuration and an open configuration of the container, both the half-shells (2, 3) featuring a respective lateral delimiting wall (5, 9) having a first exterior surface portion (6, 10) which extends along generatrices of a cylinder and a second exterior surface portion (7, 12) that extends inside said cylindrical generatrices, in the closed configuration of the container (1) the strip (4) being superimposed at least on the lateral delimiting wall (5, 9) of both half-shells and mainly or completely positioned within a recess (26) present in at least the second exterior surface portion (7, 12) of the lateral delimiting wall (5, 9) of both half-shells (2, 3).

CONTAINER FOR SURPRISES, PARTICULARLY FOR CHOCOLATE EGGS

DESCRIPTION

The present invention relates to a container for surprises, particularly for chocolate eggs.

It is well known that containers for surprises for chocolate eggs comprise two half-shells hinged together operatively between a closed configuration and an open configuration of the container.

As such products are intended for children, it is indispensable to ensure that they can be handled in total safety without any risk of accidental swallowing.

For this reason the two half-shells are as a rule reciprocally constrained so that one cannot come detached from the other when they are handled.

The constraint between the two half-shells must however be able to permit the container to be gripped by the processing machine during the packing of the egg and the container to settle inside the egg without the latter being damaged.

One of the most widespread solutions on the market today envisages that the cylindrical lateral delimiting walls of the half-shells have, at least in the area of reciprocal hinging, weakened lines that undergo breakage once the container is opened. The break lines delimit a portion of lateral delimiting wall which, on being detached from the rest of the lateral delimiting wall, defines a longitudinal strip which keeps the two half-shells connected together even in the open configuration of the container.

The longitudinal strip resists well to stresses of a tractional and torsional nature and thus makes it possible to have a container that is safe for the child. Safety is in fact governed by strict laws and regulations which impose compliance with minimum values of mechanical resistance to traction and/or torsion.

The drawback consists in the fact that the safety of the container is tied to its capacity to be torn and consequently, after opening, the container can no longer be correctly reused for its containing function, as its structure is irreversibly deteriorated.

The technical task the present invention has set itself is therefore to realize a container for surprises, particularly for chocolate eggs, which allows the aforementioned technical drawbacks of the prior art to be overcome.

Within the scope of this technical task, one object of the invention is to realize a container for surprises, particularly for chocolate eggs, which can be handled in total safety without any risk of accidental swallowing.

Another object of the invention is to realize a container for surprises, particularly for chocolate eggs, which can be conveniently used in a processing machine.

A last but not least object of the invention is to realize a container for surprises, particularly for chocolate eggs, which is completely recyclable and reusable.

The technical task, as well as these and other objects, according to the present invention are achieved by realizing a container for surprises, particularly for chocolate eggs, comprising two half-shells and at least one strip by means of which said half-shells are operatively connected together between a closed configuration and an open configuration of the container, characterized in that both half-shells feature a respective lateral delimiting wall having a first exterior surface portion which extends along generatrices of a cylinder and a second exterior surface portion that extends on the inside of said cylindrical generatrices, and that in the closed configuration of the container said at least one strip is superimposed on said lateral delimiting wall of both half-shells, being mainly or completely positioned within a recess present in said second exterior surface portion of said lateral

delimiting wall of both half-shells.

Preferably, with reference to any section of said lateral delimiting wall orthogonal to the cylindrical generatrices of said first exterior surface portion, the thickness of the part of said delimiting wall to which said second exterior surface portion belongs is not smaller than the thickness of the part of said delimiting wall to which said first exterior surface portion belongs.

Preferably, both in the closed configuration and in the open configuration of the container, said strip is connected exclusively at the two longitudinal ends thereof to said half-shells.

Preferably, said recess extends longitudinally parallel to said cylindrical generatrices and has a constant depth.

Preferably, in the closed configuration of the container said strip extends longitudinally along said longitudinal recess.

Preferably, said strip has a flattened conformation; in an intermediate portion thereof it has a widthwise narrowing and in the closed configuration of the container it exhibits a concavity turned toward the bottom of said recess.

Preferably, said strip has at least one foot for connecting to the bottom of said recess, said connecting foot being configured in such a way as to position said strip at a distance from the bottom of said recess.

Further characteristics and advantages of the invention will be more apparent from the description of a preferred, but not exclusive embodiment of the container for surprises, particularly for chocolate eggs, according to the invention, illustrated by way of non-restrictive example in the appended drawings, in which:

figure 1 shows a side elevation view of the container for surprises for chocolate eggs, in the closed configuration;

figure 2 shows a side elevation view of the container of figure 1, in the closed configuration, rotated by 90° relative to the axis of the cylindrical portions of the two half-shells;

figure 3 shows a plan view of the container of figure 1, in the open configuration;

figure 4 shows a side elevation view of the container of figure 1, in the open configuration, cut along a plane containing the axis of the cylindrical portions of the two half-shells;

figure 5 shows a perspective view of a variant of the container in which the perimeter edge of the open base of one half-shell is configured with a downwardly slanting portion to facilitate the closure between the two half-shells.

With reference to the aforementioned figures, there is shown a container for surprises, particularly for chocolate eggs, indicated overall with the reference number 1.

The container 1 comprises a first half-shell 2, a second half-shell 3 and a strip 4 by means of which the half-shells 2 and 3 are operatively connected together between a closed configuration and an open configuration of the container 1.

The first half-shell 2 features a closed base 13, an open base 14 and a lateral delimiting wall 5 having a first exterior surface portion 6 that extends along generatrices of a cylinder having an axis 8 and a second exterior surface portion 7 that extends on the inside of said cylindrical generatrices.

The second half-shell 3 in turn features a closed base 15, an open base 16 coupled with the open base 14 of the first half-shell 2 in the closed configuration of the container 1, and a lateral delimiting wall 9 having a first exterior surface portion 10 that extends along generatrices of a cylinder having an axis 11 and a second exterior surface portion 12 that extends inside said cylindrical generatrices.

With reference to any section of the lateral delimiting wall 5 of the first half-shell 2 orthogonal to the axis 8, the thickness of the part 17 of the delimiting wall 5 to which the second exterior surface portion 7 belongs is not smaller than the thickness of the part 18 of the delimiting wall 5 to which the first exterior surface portion 6 belongs. More precisely, the thickness of the part 17 is constant and slightly larger than the thickness, likewise constant, of the part 18.

Analogously, with reference to any section of the lateral delimiting wall 9 of the second half-shell 3 orthogonal to the axis 11, the thickness of the part 19 of the delimiting wall 9 to which the second exterior surface portion 12 belongs is not smaller than the thickness of the part 20 of the delimiting wall 9 to which the first exterior surface portion 10 belongs. More precisely, the thickness of the part 19 is slightly larger than the thickness of the part 20.

The exterior surface of the lateral delimiting wall 9 of the second half-shell 3 exhibits, in proximity to the open base 16, a perimeter step 21 which delimits an apical perimeter area 22 of the lateral delimiting wall 9 with a reduced thickness suitable for accommodating an apical perimeter area 23 of the lateral delimiting wall 5 of the first half-shell 2.

In the closed configuration of the container 1 in particular, the perimeter edge of the open base 14 of the first half-shell 2 goes into contact against the perimeter step 21.

The degree of the reduction in thickness of the apical perimeter area 22 of the lateral delimiting wall 9 is substantially equal to the degree of thickness of the lateral delimiting wall 5, so that in the closed configuration of the container 1, in which the apical perimeter area 23 is fitted over the apical perimeter area 22, the exterior surface of the apical perimeter area 23 is disposed on the extension of the

exterior surface of the area of the lateral delimiting wall 9 adjacent to the apical perimeter area 22.

A stable mechanical attachment between the half-shells 2 and 3 in the closed configuration of the container 1 is assured by the snap coupling between a rib 24 present on the exterior surface of the apical perimeter area 22 and a groove 25 which has a shape mating with the rib 24 and is present on the interior surface of the apical perimeter area 23.

According to a salient aspect of the invention, in the closed configuration of the container 1, the strip 4 is superimposed on the lateral delimiting walls 5 and 9, being positioned mainly or completely inside a recess 26 of the second exterior surface portion 7 and 12 of the lateral delimiting walls 5 and 9.

The strip 4 is connected, at a longitudinal end 27 thereof, to the half-shell 2 and, at a longitudinal end 28 thereof, to the half-shell 3. There are no other areas of connection of the strip 4 to the half-shells 2 and 3, neither in the closed configuration nor in the open configuration of the container 1.

In the specific case, the recess 26 has a part 26a which extends longitudinally parallel to the axis 8 and a part 26b which extends parallel to the axis 11. In the closed configuration of the container 1, in which the axes 8 and 11 are coaxial, the part 26a and the part 26b are mutually juxtaposed.

The recess 26 has a flat bottom 31 and a constant depth up to the longitudinal ends thereof, one of which ends at a tapered connecting portion 29 between the closed base 13 and the lateral delimiting wall 5 of the first half-shell 2, whereas the other ends at a tapered connecting portion 30 between the closed base 15 and the lateral delimiting wall 9 of the second half-shell 3.

The strip 4 has a flattened conformation and, in an intermediate portion thereof, it

has a widthwise narrowing 32 which increases its capacity to resist torsion.

In the closed configuration of the container 1 the strip 4 is superimposed, with a main face thereof, on the bottom 31 of the recess 26 and is curved in a longitudinal direction in such a way that the concavity is facing toward the bottom 31 of the recess 26.

The strip 4 exhibits a first foot 33 by means of which the longitudinal end 27 thereof is attached to the bottom of the recess 26 and a second foot 34 by means of which the longitudinal end 28 thereof is attached to the bottom of the recess 26.

In the closed configuration of the container 1 the attaching feet 33 and 34 create a space between the strip 4 and the bottom 31 of the recess 26 and are positioned at the same distance from the step 21, so that for half a length the strip 4 is superimposed on the half-shell 2 and for half a length it is superimposed on the half-shell 3.

Finally, the attaching feet 33 and 34 are dimensioned so as to be completely contained within the recess 26.

The invention offers innumerable advantages.

The container preserves its structural integrity even after being opened. It may therefore be not only recycled, if the material it is composed of is recyclable, but also reused as such by the manufacturer.

As an incentive to return the container to the manufacturer a reward can be provided, consisting for example in the supply of a free chocolate egg for every minimum quantity of containers returned to the manufacturer.

In the closed configuration, the two half-shells 2 and 3 do not have a possibility of relative rotation about the coaxially disposed axes 8 and 11 since the open bases 14 and 16 which couple together do not have an entirely circular profile. This

contributes to making the closed configuration of the container 1 extremely stable. The length of the strip can be chosen at will without any particular limitations according to the capacity of mechanical resistance to torsion it is desired to impart thereto at the design stage.

The providing of a recess 26 in which the strip 4 is disposed facilitates automation of the process of packing the chocolate egg by facilitating robotized pick-up of the egg and enabling the container to settle inside the egg without the latter being able to undergo damage.

With reference in particular to figure 5, the perimeter edge of the open base of at least one half-shell, for example the perimeter edge of the open base 16, is configured with a downwardly slanting portion 35 to facilitate the closure between the two half-shells 2 and 3.

The downwardly slanting portion 35 is in a position diametrically opposite to the area where the strip 4 is provided for connecting the half-shells 2 and 3 and is formed by a cut in the face of the open base 16.

In particular, externally to the cut the perimeter edge of the open base 16 extends in a plane orthogonal to axis 11, whereas at the site of the cut the perimeter edge of the open base 16 extends in a plane that is inclined relative to the axis 11.

The downwardly slanting portion 35 speeds up the operation of manually opening the capsule to insert the toy and then closing it again and consequently implies a lower cost of labour and ultimately a lower purchase cost of the capsule.

The container for surprises thus conceived is susceptible of numerous modifications and variants, all falling within the scope of the inventive concept; moreover, all the details may be replaced with other technically equivalent elements.

In practice, the materials used, as well as the dimensions, can be any whatsoever according to need and the state of the art.

CLAIMS

1. A container (1) for surprises, particularly for chocolate eggs, comprising two half-shells (2, 3) and at least one strip (4) by means of which said half-shells (2, 3) are operatively connected together between a closed configuration and an open configuration of the container, characterized in that both half-shells (2, 3) feature a respective lateral delimiting wall (5, 9) having a first exterior surface portion (6, 10) which extends along generatrices of a cylinder and a second exterior surface portion (7, 12) that extends on the inside of said cylindrical generatrices, and that in the closed configuration of the container (1) said at least one strip (4) is superimposed on said lateral delimiting wall (5, 9) of both half-shells (2, 3) being mainly or completely housed within a recess (26) present in at least said second exterior surface portion (7, 12) of said lateral delimiting wall (5, 9) of both half-shells (2, 3).
2. The container (1) for surprises according to claim 1, characterized in that, with reference to any section of said lateral delimiting wall (5, 9) orthogonal to the cylindrical generatrices of said first exterior surface portion (6, 10), the thickness of the part (17, 19) of said delimiting wall (5, 9) to which said second exterior surface portion (7, 12) belongs is not smaller than the thickness of the part (18, 20) of said delimiting wall to which said first exterior surface portion (6, 10) belongs.
3. The container (1) for surprises according to any preceding claim, characterized in that both in the closed configuration and in the open configuration of the container said strip (4) is connected exclusively at the two longitudinal ends thereof to said half-shells (2, 3).
4. The container (1) for surprises according to any preceding claim,

- characterized in that the recess (26) extends longitudinally parallel to said cylindrical generatrices.
5. The container (1) for surprises according to the preceding claim, characterized in that in the closed configuration said strip (4) extends longitudinally along said longitudinal recess (26).
 6. The container (1) for surprises according to any preceding claim, characterized in that said strip (4) has a flattened conformation.
 7. The container (1) for surprises according to the preceding claim, characterized in that said strip (4), in an intermediate portion thereof, has a widthwise narrowing (32).
 8. The container (1) for surprises according to any preceding claim, characterized in that said recess (26) has a constant depth.
 9. The container (1) for surprises according to any preceding claim, characterized in that said strip (4) has at least one foot (27, 28) for attaching to the bottom (31) of said recess (26), said attaching foot (27, 28) being configured in such a way as to position the strip (4) at a distance from the bottom (31) of said recess (26).
 10. The container (1) for surprises according to the preceding claim, characterized in that in the closed configuration said strip (4) exhibits a concavity facing toward the bottom (31) of said recess (26).
 11. The container (1) according to any preceding claim, characterized in that the perimeter edge of the open base (16) of at least one half-shell (3) is configured with a downwardly slanting portion (35) to facilitate closing between the two half-shells (2, 3).
 12. The container (1) according to the preceding claim, characterized in that said a

downwardly slanting portion (35) is formed by a cut in the face of said open base (16).

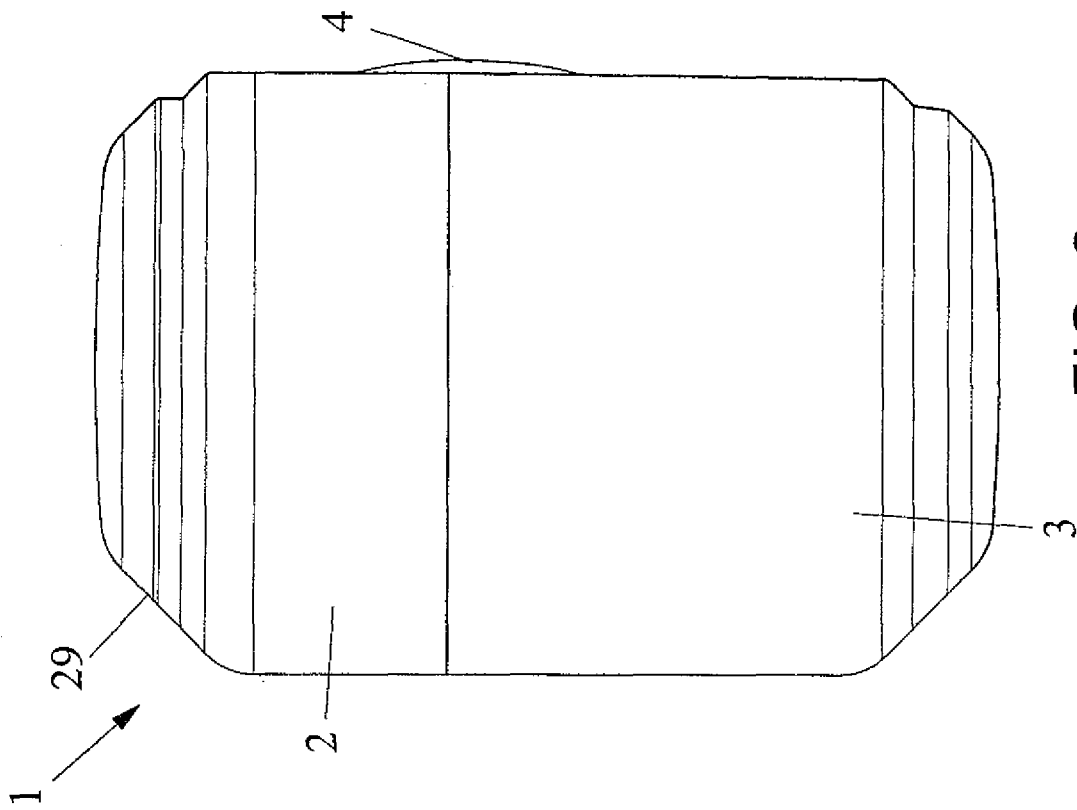

FIG. 2

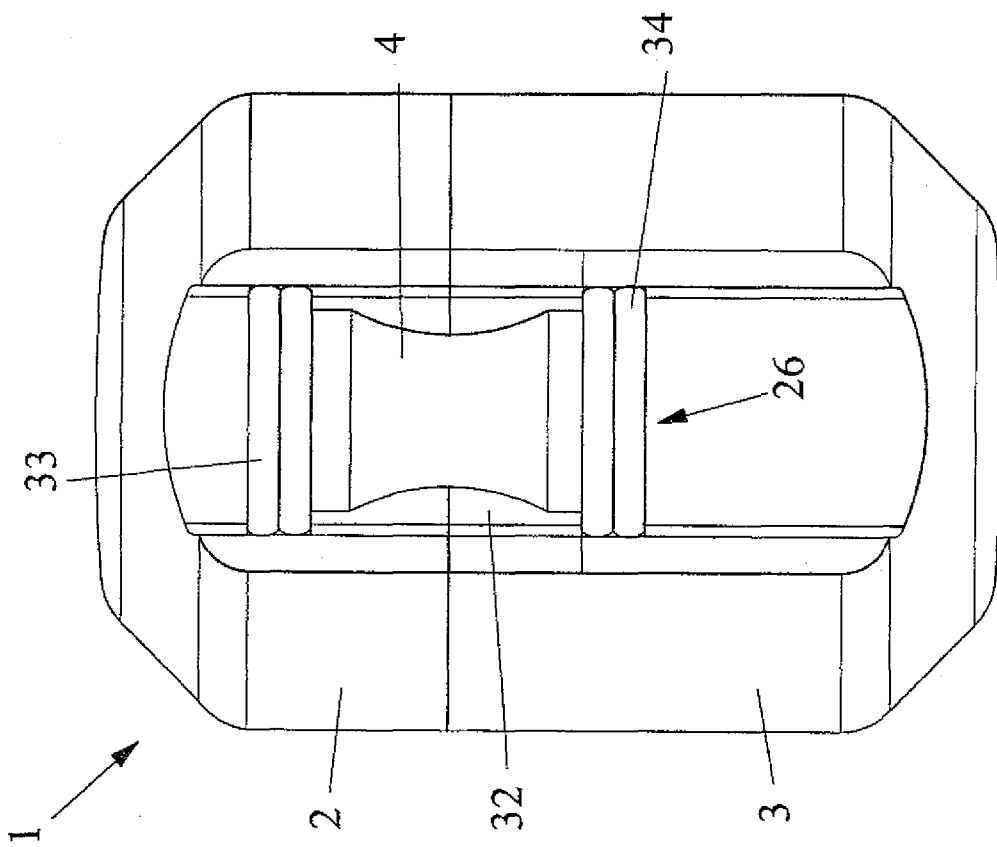

FIG. 1

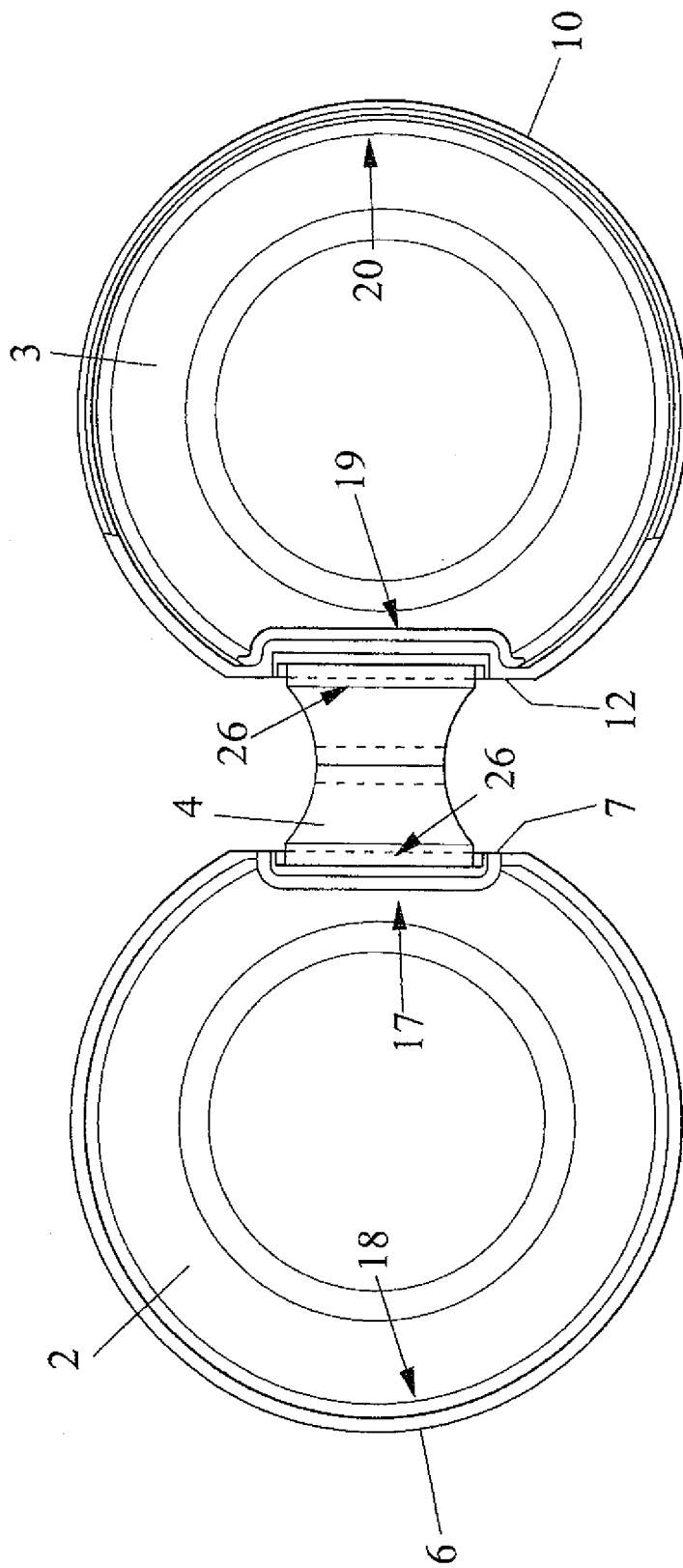

FIG. 3

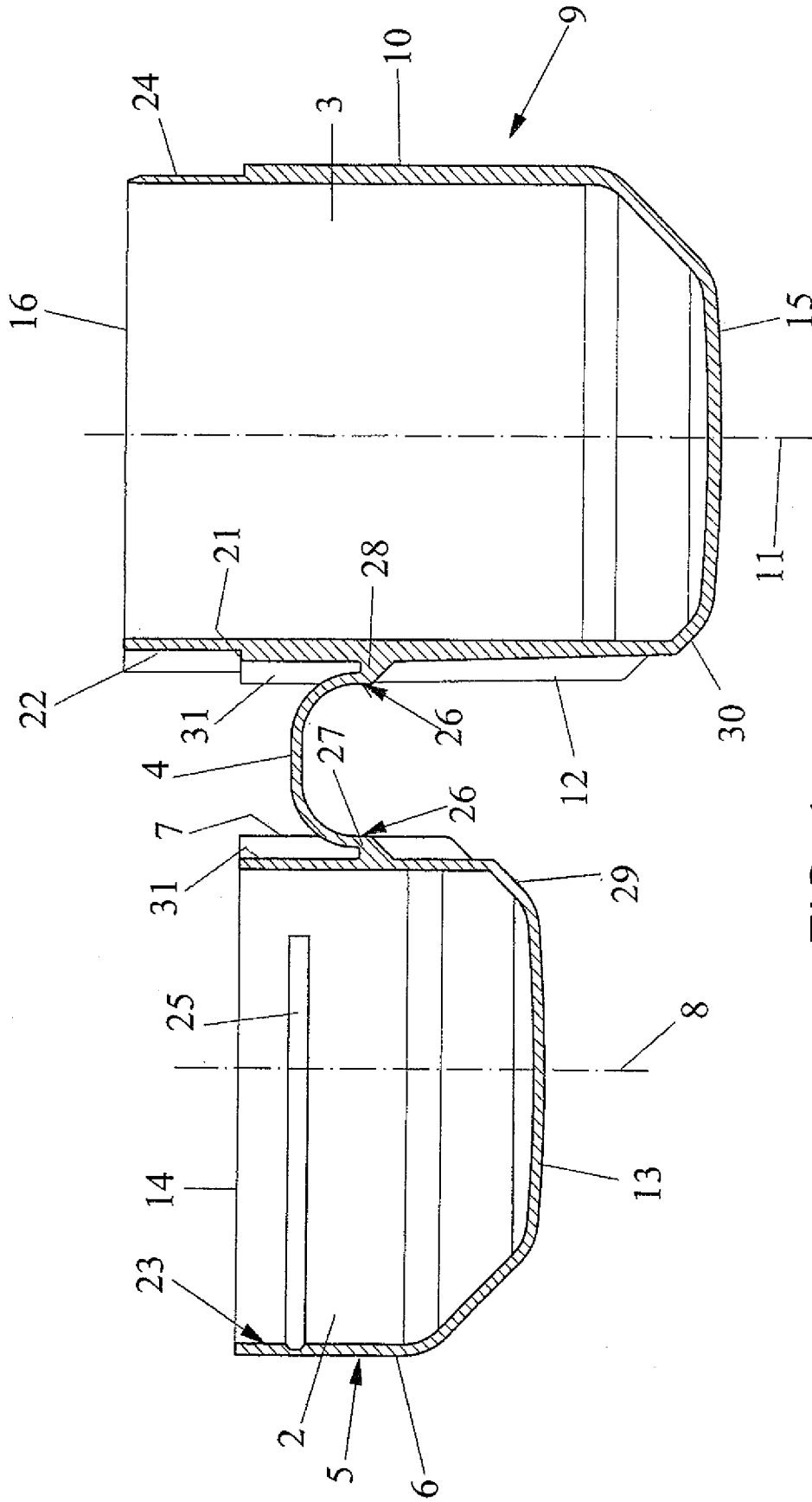

FIG. 4

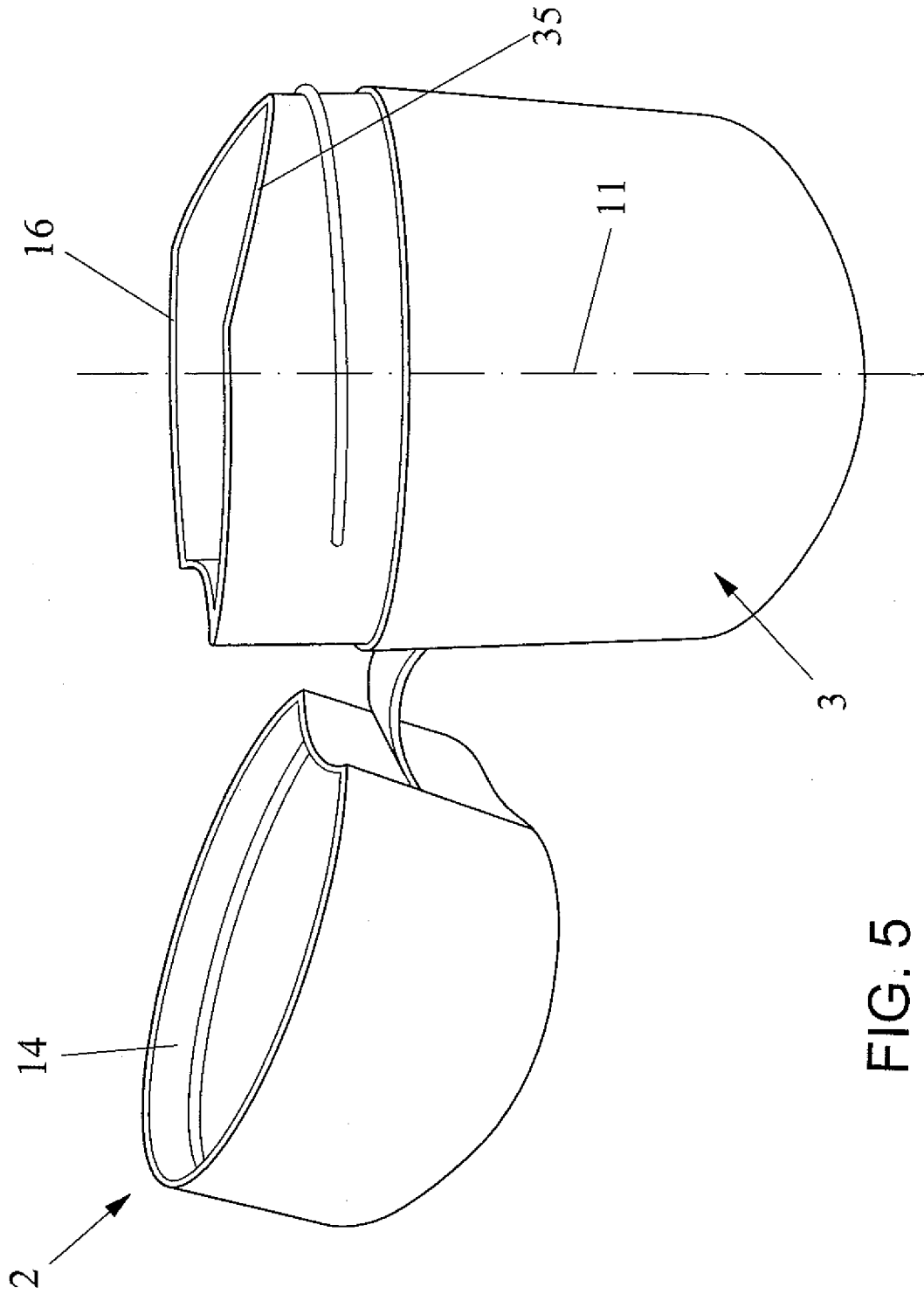

FIG. 5

INTERNATIONAL SEARCH REPORT

International application No
PCT/EP2011/073205

A. CLASSIFICATION OF SUBJECT MATTER
INV. B65D43/16 B65D85/60
ADD.
According to International Patent Classification (IPC) or to both national classification and IPC

B. FIELDS SEARCHED
Minimum documentation searched (classification system followed by classification symbols)
B65D

Documentation searched other than minimum documentation to the extent that such documents are included in the fields searched

Electronic data base consulted during the international search (name of data base and, where practical, search terms used)
EPO-Internal

C. DOCUMENTS CONSIDERED TO BE RELEVANT

Category*	Citation of document, with indication, where appropriate, of the relevant passages	Relevant to claim No.
X	WO 2007/074355 A1 (MAGIC PRODUCTION GROUP M P G S [LU]; SALICE GIUSEPPE [BE]) 5 July 2007 (2007-07-05)	1-6,8,9
Y	the whole document	7,11,12
Y	----- US 5 860 549 A (ALLERS BRIAN SCOTT [US] ET AL) 19 January 1999 (1999-01-19) figure 5	7
Y	----- EP 0 779 226 A1 (BOEHRINGER MANNHEIM GMBH [DE] ROCHE DIAGNOSTICS GMBH [DE]) 18 June 1997 (1997-06-18) figure 4	11,12
X	----- DE 74 36 695 U (VEDDER & CO GMBH [DE]) 27 February 1975 (1975-02-27) the whole document	1,2
	----- -/--	

Further documents are listed in the continuation of Box C.

See patent family annex.

* Special categories of cited documents :

"A" document defining the general state of the art which is not considered to be of particular relevance

"E" earlier document but published on or after the international filing date

"L" document which may throw doubts on priority claim(s) or which is cited to establish the publication date of another citation or other special reason (as specified)

"O" document referring to an oral disclosure, use, exhibition or other means

"P" document published prior to the international filing date but later than the priority date claimed

"T" later document published after the international filing date or priority date and not in conflict with the application but cited to understand the principle or theory underlying the invention

"X" document of particular relevance; the claimed invention cannot be considered novel or cannot be considered to involve an inventive step when the document is taken alone

"Y" document of particular relevance; the claimed invention cannot be considered to involve an inventive step when the document is combined with one or more other such documents, such combination being obvious to a person skilled in the art.

"&" document member of the same patent family

Date of the actual completion of the international search 22 March 2012	Date of mailing of the international search report 30/03/2012
--	--

Name and mailing address of the ISA/ European Patent Office, P.B. 5818 Patentlaan 2 NL - 2280 HV Rijswijk Tel. (+31-70) 340-2040, Fax: (+31-70) 340-3016	Authorized officer Pernice, Ciro
--	---

INTERNATIONAL SEARCH REPORT

International application No
PCT/EP2011/073205

C(Continuation). DOCUMENTS CONSIDERED TO BE RELEVANT		
Category*	Citation of document, with indication, where appropriate, of the relevant passages	Relevant to claim No.
A	EP 1 604 911 A1 (MAGIC PRODUCTION GROUP M P G S [LU]) 14 December 2005 (2005-12-14) the whole document	1-12
A	----- US 4 124 135 A (WEDER ERWIN H ET AL) 7 November 1978 (1978-11-07) the whole document -----	1-12

INTERNATIONAL SEARCH REPORT

Information on patent family members

International application No
PCT/EP2011/073205

Patent document cited in search report	Publication date	Patent family member(s)	Publication date
WO 2007074355	A1	05-07-2007	AT 515453 T 15-07-2011
			CA 2629659 A1 05-07-2007
			CN 101309838 A 19-11-2008
			EP 1966058 A1 10-09-2008
			EP 2325100 A1 25-05-2011
			ES 2368934 T3 23-11-2011
			JP 2009515789 A 16-04-2009
			SI 1966058 T1 30-11-2011
			US 2008283539 A1 20-11-2008
			WO 2007074355 A1 05-07-2007

US 5860549	A	19-01-1999	NONE

EP 0779226	A1	18-06-1997	AT 183709 T 15-09-1999
			DE 19546684 A1 19-06-1997
			EP 0779226 A1 18-06-1997
			ES 2136938 T3 01-12-1999
			JP 3410619 B2 26-05-2003
			JP 3742622 B2 08-02-2006
			JP 9183474 A 15-07-1997
			JP 2003261160 A 16-09-2003
			US 5788064 A 04-08-1998

DE 7436695	U	27-02-1975	NONE

EP 1604911	A1	14-12-2005	AR 049813 A1 06-09-2006
			BR PI0510877 A 27-11-2007
			CA 2565920 A1 24-11-2005
			CN 1922079 A 28-02-2007
			EP 1604911 A1 14-12-2005
			JP 4739334 B2 03-08-2011
			JP 2007537941 A 27-12-2007
			KR 20070038044 A 09-04-2007
			RU 2367587 C2 20-09-2009
			US 2007172555 A1 26-07-2007
			WO 2005110880 A1 24-11-2005
			ZA 200610516 A 28-01-2009

US 4124135	A	07-11-1978	NONE
