

1 585 060

- (21) Application No 30086/76 (22) Filed 20 July 1976
- (23) Complete Specification filed 1 July 1977
- (44) Complete Specification published 25 February 1981
- (51) INT. CL.³ F21V 31/02 // B60Q 1/02
- (52) Index at acceptance
F4R 364 410 41Y PR
- (72) Inventor: ROYSTON NEVILLE HANCOX



(54) LAMP ASSEMBLIES

(71) We, LUCAS INDUSTRIES LIMITED, a British Company of Great King Street, Birmingham, B19 2XF, do hereby declare the invention for which we pray that a Patent may be granted to us and the method by which it is to be performed, to be particularly described in and by the following statement:—

This invention relates to a lamp assembly particularly, though not exclusively, for use on a motor vehicle.

According to the present invention, there is provided a lamp assembly comprising a hollow body including a lens element, said body having an opening therein; an hermetically sealed filament assembly extending into said hollow body through said opening, the filament assembly include a base, conductors extending through the base, and a mounting flange secured to the base and engaging a portion of said body around said opening, hermetic sealing being provided between the conductors and the base and between the mounting flange and the base; and a sealing member disposed on a side of said mounting flange remote from said body portion and engaging said mounting flange and said body so as to provide an hermetic seal between said mounting flange and said body.

Advantageously, said sealing member engages said body on a side wall of said opening.

The sealing member is preferably radially spaced from said base of the filament assembly.

Desirably, said sealing member provides both a peripheral hermetic seal and an axial hermetic seal between said mounting flange and said body.

Preferably, said sealing member is mounted on a surface of said mounting flange remote from said body portion.

Means may be provided to urge said sealing member into engagement with said body in the case where said sealing member is mounted on said mounting flange, or into engagement simultaneously with said body and said mounting flange in the case where it is not.

Conveniently a cap overlies said opening in the body and has an aperture therein through which said filament assembly passes.

Desirably, said urging means is constituted by said cap, which is engaged with said body so as to act on said sealing member and thereby compresses the latter.

Alternatively, said urging means may include

at least one resilient element acting on said sealing member.

The or each resilient element may be disposed between said cap and said sealing member. In this case, said sealing member may be provided with a pressure plate on a surface thereof remote from said mounting flange, against which pressure plate the or each said resilient elements acts.

Alternatively, said cap may be engaged with said sealing member, and said at least one resilient element may be disposed externally of said cap so as to act against said cap.

Advantageously, said opening in the body is stepped so as to define a shoulder outwardly of the body, against which shoulder the mounting flange engages an said sealing member engages a side wall of said opening on the opposite side of said mounting flange to said shoulder.

Preferably, at least a part of a side wall of the opening tapers outwardly towards the exterior of said body, and said sealing member is correspondingly tapered.

Most advantageously, said mounting flange and said sealing member are correspondingly stepped.

Embodiments of the present invention will now be described by way of example, with reference to the accompanying drawings, in which:

Figure 1 is a section through part of a first embodiment of a lamp assembly according to the present invention,

Figure 2 is a plan view of part of the lamp assembly of Figure 1,

Figure 3 is an end view of part of the lamp assembly of Figure 1,

Figure 4 is a section through part of a second embodiment of a lamp assembly according to the present invention,

Figure 5 is a plan view of part of the lamp assembly of Figure 4,

Figure 6 is an end view of part of the lamp assembly of Figure 4,

Figure 7 is an underneath perspective view of a sealing ring of the lamp assembly of Figures 4 to 6,

Figure 8 is a perspective view of part of a body of the lamp assembly of Figure 4 to 6,

Figure 9 is a section through part of a third embodiment of a lamp assembly according to the present invention,

5
10
15
20
25
30
35
40
45
50

55
60
65
70
75
80
85
90
95
100

Figure 10 is a plan view of part of the lamp assembly of Figure 9,

Figure 11 is an end view of part of the lamp assembly of Figure 9,

5 Figure 12 is a section through part of a fourth embodiment of a lamp assembly according to the present invention,

Figure 13 is a plan view of part of the lamp assembly of Figure 12,

10 Figure 14 is an end view of part of the lamp assembly of Figure 12,

Figure 15 is a section through part of a fifth embodiment of a lamp assembly according to the present invention,

15 Figure 16 is a plan view of part of the lamp assembly of Figure 15,

Figure 17 is an end view of part of the lamp assembly of Figure 15,

20 Figure 18 is a plan view of a resilient element forming part of the lamp assembly of Figure 15,

Figure 19 is a section through part of a sixth embodiment of a lamp assembly according to the present invention,

25 Figure 20 is a plan view of part of the lamp assembly of Figure 19, and

Figure 21 is an end view of part of the lamp assembly of Figure 19.

Referring to Figures 1 to 3, a first embodiment of the lamp assembly of the present invention comprises a hollow body 10, only part of which is shown, including a reflector portion 11 and a lens element (not shown). The reflector portion 11 is moulded from a low profile, thermosetting polyester dough moulding compound, and has a spigot 12 integrally extending from the rear thereof. An opening 13 extends through the spigot 12 to provide communication between the interior and the exterior of body 10. The opening 13 is stepped so as to define an annular shoulder 14 which faces outwardly of the body 10.

An hermetically sealed filament assembly in the form of a halogen bulb 16 extends through the opening 13, and is provided with an annular flange 17 which extends around a base portion 18 of the bulb 16 and which is joined thereto in a manner so as to create an hermetic seal therebetween. The periphery of the flange 17 engages a side wall 21 of the opening 13. One surface of the flange 17 is engaged with the shoulder 14 on the body 10, and the opposite surface of the flange 17 has a sealing ring 19 mounted thereon in a manner so as to create an hermetic seal therebetween. The sealing ring 19 is moulded from silicone rubber and extends round the base portion 18 of the bulb 16, being radially spaced therefrom by an annular gap 20. A radially outer surface of the sealing ring 19 engages the side wall 21 of the opening 13 on the opposite side of the mounting flange 17 to the shoulder 14. The side wall 21 is stepped so as to define an annular shoulder 22 and inner and outer parts 24a and 24b, respectively of said side wall; the outer surface of the sealing ring 19 is correspondingly stepped at 23. The

outer part of 24b of the side wall 21 tapers outwardly, and the outer surface of the sealing ring 19 is correspondingly tapered.

A metal cap 26 is fitted over the end of spigot 12, and has an aperture 27 therein through which the bulb 16 passes. The cap 26 is engaged with the body 10 by means of a bayonet fixing, and also engages a surface of the sealing ring 19 remote from mounting flange 17. The cap 26 is arranged to compress the sealing ring 19 when engaged with the body 10, thereby urging the sealing ring 19 further into engagement with the side walls 21 of opening 13 so as to create a peripheral hermetic seal therebetween. The tapered part 24b of the side wall 21 and the corresponding taper on the sealing ring 19 serve to improve this seal. Compression of the sealing ring 19 also serves to urge the flange 17 of the bulb 16 into further engagement with shoulder 14 thereby creating an axial hermetic seal therebetween and providing accurate axial location of the bulb 16.

It will be manifest from the above that the sealing ring 19 provides an hermetic seal between the bulb mounting flange 17 and the body 10, and when used in conjunction with an hermetically sealed bulb 16 enables the interior of the lamp assembly to be sealed hermetically from the surroundings. Moreover, because the sealing ring 19 acts on the mounting flange 17 of the bulb 16 rather than on the base portion 18 of the latter, the annular gap 20 can be provided so as to reduce the risk of the sealing ring 19 being affected by the heat generated by the bulb 16 particularly at its base portion 18. This is particularly important here since the body 10 of the lamp assembly is made of a dough moulding compound which has a low thermal conductivity, and therefore the heat generated by the bulb 16 will not be dissipated as quickly as would be the case if the body 10 were made of metal, for example.

A second embodiment of the lamp assembly of the present invention is shown in Figures 4 to 8 and is similar to the embodiment of figures 1 to 3 described above. Identical parts have therefore been denoted by the same reference numerals with 100 added. In this embodiment, the opening 13 is stepped so as to define a shoulder 130 in addition to the shoulder 114. Shoulder 114 is itself provided with three equiangularly spaced recesses 131 therein, and a radially extending projection 132 is associated with each recess. The shoulder 130, recesses 131 and projections 132 are shown to advantage in Figure 8.

The mounting flange 117 is stepped so as to define radially outer and inner portions 133, 134 respectively, which are each substantially annular. Portion 133 engages the shoulder 114; portion 134 is slightly spaced from the shoulder 130. The mounting flange 117 is deformed so as to define three projections 135 (only one of which is shown in Figure 4) on one surface thereof and corresponding recesses in the other

surface. The projections 135 locate respectively in the recesses 131 in the shoulder 114.

The sealing ring 119 is stepped at 136 so as to conform to the step in the mounting flange 117. The sealing ring 119 is also provided with three equi-angularly spaced projections 137 (only one of which is shown in Figure 4) which locate respectively in the aforesaid recesses in the mounting flange 117. The sealing ring 119 is shown to advantage in Figure 7. The annular gap 120 between the sealing ring 119 and the base 118 of bulb 116 is considerably larger than in the embodiment of Figures 1 to 3, except at one location 120a where the design of bulb 116 makes this impossible. The larger gap serves to reduce the risk of the hermetic seal between the bulb mounting flange 117 and the body 110 from breaking down due to heating of the sealing member 119 by the bulb 116.

A third embodiment of the lamp assembly of the present invention is shown in Figures 9 to 11 and is generally similar to the embodiment described above with reference to Figures 4 to 8. Similar parts have, therefore, been accorded the same reference numerals, but with 100 added. In this embodiment the cap 226 has a cylindrical recess 240 therein, which locates in a similar cylindrical recess in the sealing ring 219.

A spring 241 engages over lugs 242 on the spigot 212 which form part of the bayonet fixing for the cap 226, and acts on the cap 226 so as to urge the latter against the sealing ring 219. This in turn urges the sealing ring 219 into further engagement with the side wall 221 of the opening 213 thereby improving the hermetic seal between the bulb 216 and body 210. In fact, the cap 226 is first attached to the body 210 by means of the bayonet fixing, and is arranged to compress the sealing ring 219. However, the pressure exerted on the hermetic seal between bulb 216 and body 210 may deteriorate due to the heat generated by the bulb 216. The provision of spring 241 ensures that a pressure is maintained on the hermetic seal in this event. It will be manifest that because the spring 241 is mounted externally of the cap 226, it may be easily attached to the remainder of the lamp assembly.

More particularly, the spring 241 comprises a U-shaped portion 243 which engages over one of the lugs 242, a pair of looped portions 244 integral with either end of portion 243 and accommodated within recess 240 in the cap 226, and a pair of end portions 245 integral with the portions 244 respectively and each locating over respective ones of the lugs 242.

A fourth embodiment of the lamp assembly of the present invention is shown in Figures 12 to 14, and is generally similar to the embodiment of Figure 4 to 6 described above. Similar parts have, therefore, been accorded the same reference numerals but with 200 added. In this embodiment, the cap 326 is spaced from the sealing ring 319, and three resilient elements

350 are riveted to the cap 326 and are disposed in the space between the cap 326 and the sealing ring 319. An annular pressure plate 351 is provided on a surface of the sealing ring 319 remote from mounting flange 317, and is engaged by the resilient elements 350. When the cap 326 is engaged with the body 310, the resilient elements 350 act on the pressure plate 351 so as to urge the sealing ring 319 into further engagement with the side wall 321 of opening 313, thereby enhancing the hermetic seal between the bulb 316 and the body 310.

In Figures 15 to 18 there is illustrated a fifth embodiment of the lamp assembly of the present invention which is similar to the lamp assembly of Figures 12 to 14, similar parts being accorded the same reference numerals, but with 100 added. In this embodiment, the sealing ring 419 has an annular groove 460 in the surface thereof which is engaged by the pressure plate 451. Also, the cap 426 is made of ZYTEL (Registered Trade Mark), a thermo-setting polyamide plastics material. The three resilient elements 450 are of a slightly different construction to those of the lamp assembly of Figures 12 to 14, in that they are each provided with a groove 461 extending along their lengths and barbs 462 on a portion thereof which is push-fitted onto a respective post (not shown) on the cap 426. One of the resilient elements 450 is shown in detail in Figure 18.

A sixth embodiment of the lamp assembly of the present invention is shown in Figures 19 to 21, and is substantially identical to the embodiment of Figures 15 to 18, identical parts being denoted by the same reference numerals but with 100 added. In this embodiment, a compression spring 570 replaces the three resilient elements 450, and is disposed around the base 518 of the bulb 516.

In the embodiments of Figures 9 to 11, Figures 12 to 14, Figures 15 to 18 and Figures 19 to 21, at least one resilient element or spring is used to act on the sealing ring, whereas in the embodiments of Figures 1 to 3 and Figures 4 to 8 the sealing ring is acted on directly by the cap. By using at least one resilient element or spring, the risk of the hermetic seal between bulb and body being broken down due to rise in temperature of the lamp assembly is minimized.

WHAT WE CLAIM IS:—

1. A lamp assembly comprising a hollow body including a lens element, said body having an opening therein; an hermetically sealed filament assembly extending into said hollow body through said opening, the filament assembly including a base, conductors extending through the base, and a mounting flange secured to the base and engaging a portion of said body around said opening, hermetic sealing being provided between the conductors and the base and between the mounting flange and the base; and a sealing member disposed on a side of said mounting flange remote from said body portion

5
10
15
20
25
30
35
40
45
50
55
60
65

70
75
80
85
90
95
100
105
110
115
120
125
130

and engaging said mounting flange and said body so as to provide an hermetic seal between said mounting flange and said body.

2. A lamp assembly as claimed in Claim 1, wherein the sealing member engages said body on a side wall of said opening.

3. A lamp assembly as claimed in Claim 1 or 2, wherein the sealing member is radially spaced from said base of the filament assembly.

4. A lamp assembly as claimed in Claim 1, 2 or 3 wherein the sealing member provides both a peripheral hermetic seal and an axial hermetic seal between said mounting flange and said body.

5. A lamp assembly as claimed in any preceding claim, wherein the sealing member is mounted on a surface of the mounting flange remote from said body portion.

6. A lamp assembly as claimed in Claim 5, wherein means is provided to urge the sealing member into engagement with the body.

7. A lamp assembly as claimed in any one of Claims 1 to 4, wherein means is provided to urge the sealing member simultaneously into engagement with the body and the mounting flange.

8. A lamp assembly as claimed in Claim 6 or 7, wherein the urging means is constituted by a cap which overlies the opening in the body and which has an aperture therein through which the filament assembly passes, the cap being engaged with the body so as to act on the sealing member and thereby compress the latter.

9. A lamp assembly as claimed in Claim 6 or 7, wherein the urging means includes at least one resilient element acting on the sealing member.

10. A lamp assembly as claimed in Claim 9, wherein a cap overlies the opening in the body and has an aperture therein through which the filament assembly passes.

11. A lamp assembly as claimed in Claim 10, wherein the or each resilient element is disposed between the cap and the sealing member.

12. A lamp assembly as claimed in Claim 11, wherein a pressure plate is provided on a surface of the sealing member remote from the mounting flange, against which pressure plate the or each resilient element acts.

13. A lamp assembly as claimed in Claim 10, wherein the cap is engaged with the sealing member, and said at least one resilient element is disposed externally of the cap so as to act against the cap.

14. A lamp assembly as claimed in any preceding claim, wherein the opening in the body is stepped so as to define a shoulder facing outwardly of the body, against which shoulder the mounting flange engages, and the sealing member engages a side wall of the opening on the opposite side of the mounting flange to said shoulder.

15. A lamp assembly as claimed in any preceding claim, wherein at least a part of a side wall of the opening tapers outwardly towards the exterior of the body, and the sealing member is correspondingly tapered.

16. A lamp assembly as claimed in any preceding claim, wherein the mounting flange and the sealing member are correspondingly stepped.

17. A lamp assembly substantially as hereinbefore described with reference to Figures 1 to 3, or Figures 4 to 8, or Figures 9 to 11, or Figures 12 to 14, or Figures 15 to 18, or Figures 19 to 21 of the accompanying drawings.

MARKS & CLERK,
Alpha Tower,
ATV Centre,
Birmingham B1 1TT

Agents for the Applicants

FIG. 1.

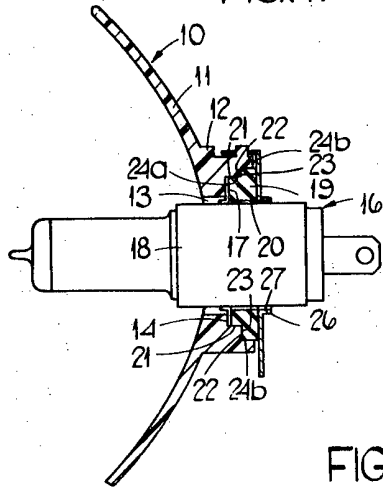

FIG. 2.

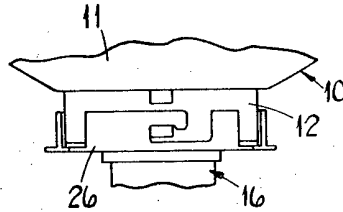

FIG. 3.

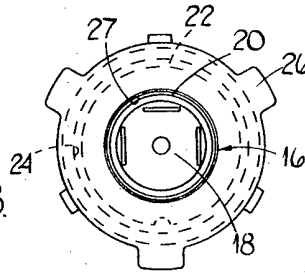

FIG. 4.

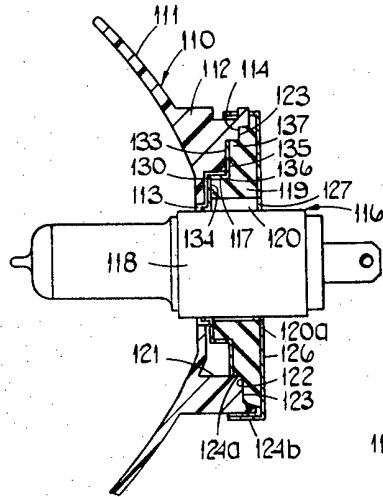

FIG. 5.

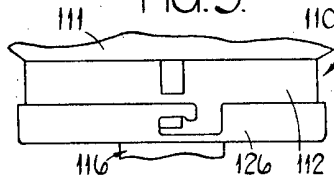

FIG. 6.

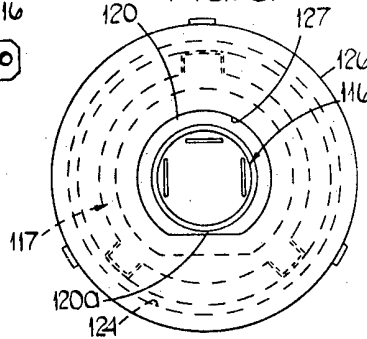

FIG. 7.

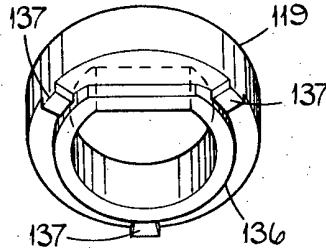

FIG. 8.

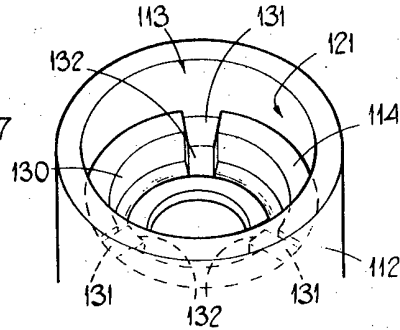

FIG. 9.

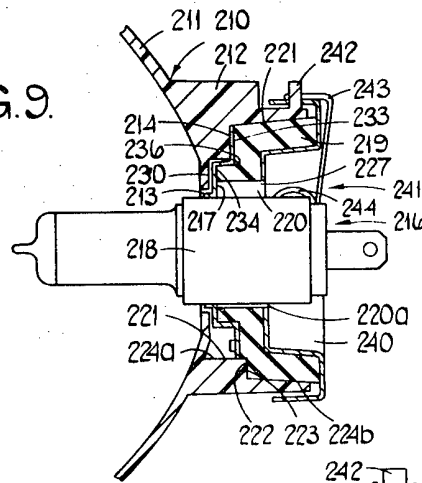

FIG. 10.

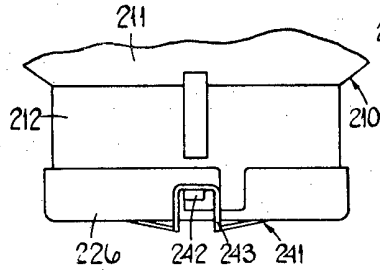
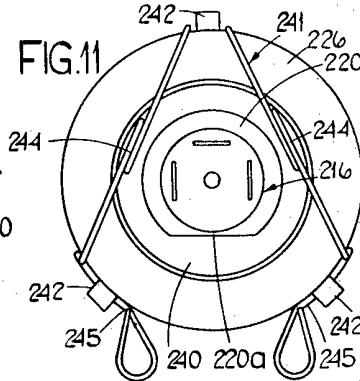
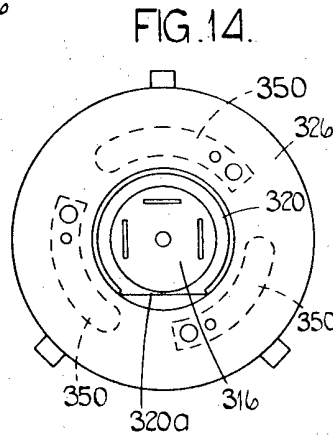
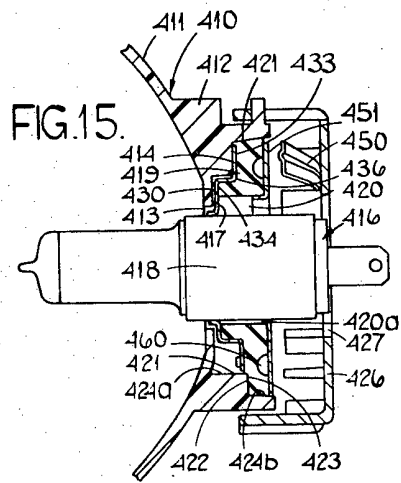
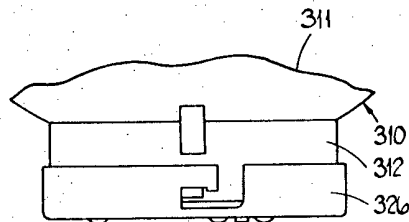
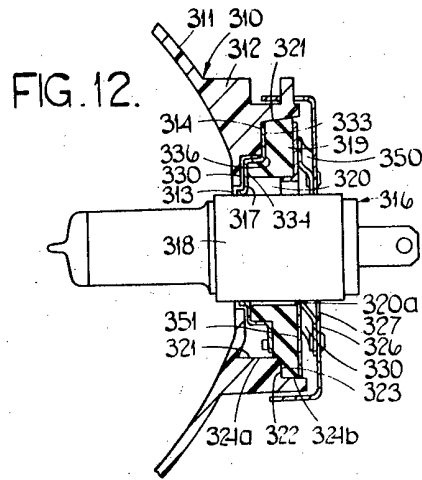

FIG. 11.





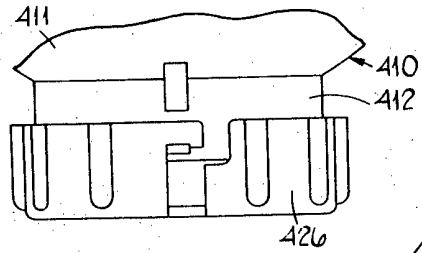

FIG. 16

FIG. 17.

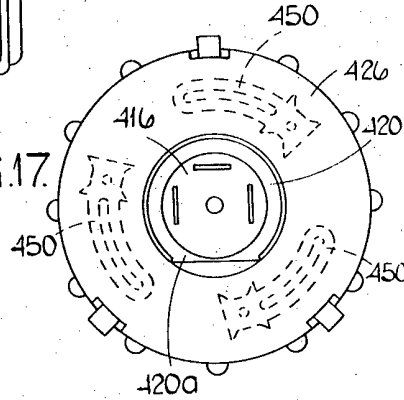

FIG. 18

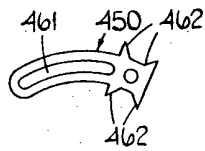

FIG. 20.

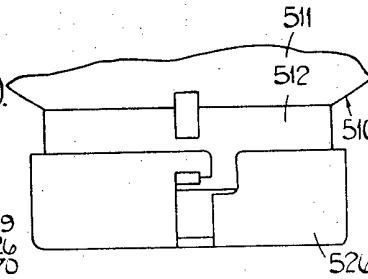

FIG. 19.

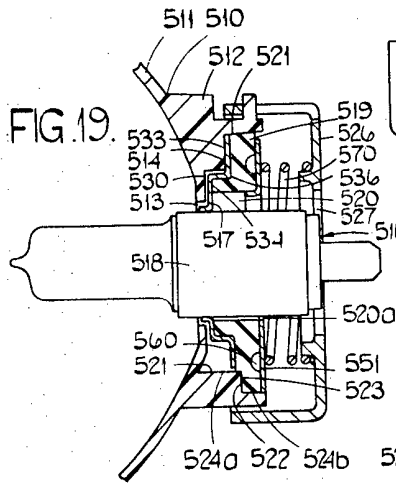

FIG. 21.

