

J. Davis,
Potato Digger.

No. 111,437.

Patented Jan. 31. 1871.

Fig: 1

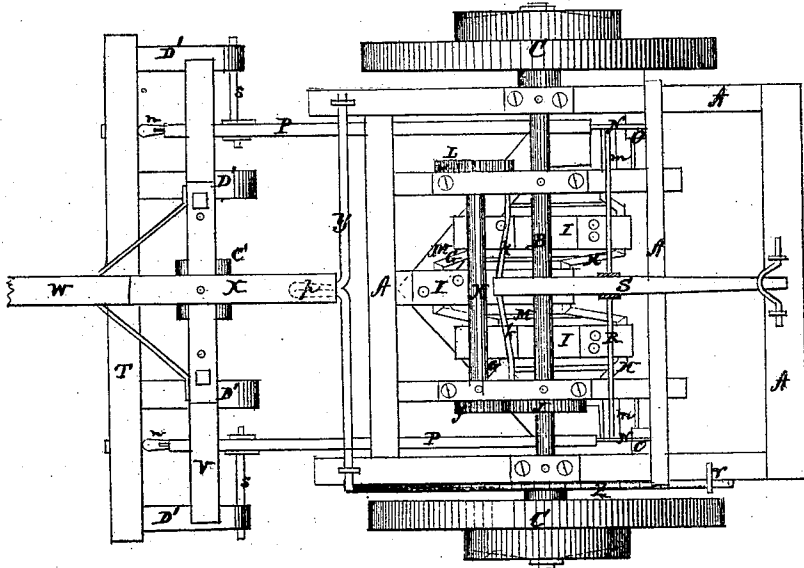

Fig: 2

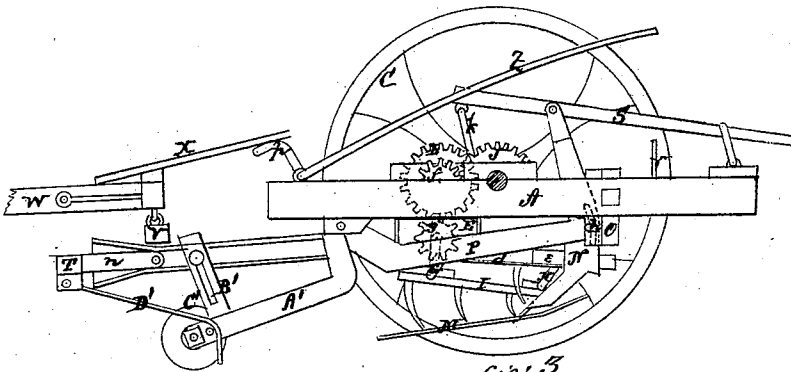
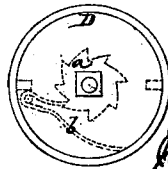

Fig: 3



Witnesses
Ed. Puert.
W. H. ...

Inventor
James Davis
per *Shandon Thason*
Atty.

United States Patent Office.

JAMES DAVIS, OF SARATOGA, NEW YORK.

Letters Patent No. 111,437, dated January 31, 1871.

IMPROVEMENT IN POTATO-DIGGERS.

The Schedule referred to in these Letters Patent and making part of the same.

To all whom it may concern:

Be it known that I, JAMES DAVIS, of the town of Saratoga, in the county of Saratoga and in the State of New York, have invented certain new and useful Improvements in Machinery for Digging Potatoes; and do hereby declare that the following is a full, clear, and exact description thereof, reference being had to the accompanying drawing and to the letters of reference marked thereon making a part of this specification.

The nature of my invention consists in the construction and arrangement of a "potato-digger," as will be hereinafter fully set forth.

In order to enable others skilled in the art to which my invention appertains to make and use the same, I will now proceed to describe its construction and operation, referring to the annexed drawing, in which—

Figure 1 is a plan view, and

Figure 2 a side view of my machine.

Figure 3 is an inside view of the hub of one of the driving-wheels.

A represents the frame of my machine, provided with suitable journal-boxes, through which passes the axle B, having upon its ends the driving-wheels C C.

The hubs of the wheels C C are box-shaped, open on the outer side, which is closed by a cap, D, secured by a nut on the outside. The wheel C is placed loose upon the axle, and can revolve on the same, while the cap D has a groove from its center, in which fits a feather on the axle, thus allowing said cap to be moved out or in on the axle, but preventing it from revolving on the same.

On the inside of the cap D is formed a ratchet-wheel, *a*, and in the hub of the wheel is a spring pawl, *b*, bearing or working in said ratchet-wheel in such a manner that when the machine moves forward the axle will be made to turn, while when it is backing the wheel will turn on the axle.

Under each side of the frame A, in front of the axle, is suspended a journal-box, E, in which a crank-shaft, G, has its bearings.

From the under side of each of the journal-boxes E a metal strap, *d*, extends toward the rear, its rear end being suspended and adjusted by means that will be hereinafter set forth.

On the rear ends of the straps *d d* are placed other journal-boxes, *e e*, for another crank-shaft, H.

On the two crank-shafts, G and H, are placed the pickers I I, which consist each of a head, with teeth on the under side, said teeth being curved toward the rear.

The pickers I I receive the necessary motion by means of a cog-wheel, J, upon the axle A, said wheel gearing with a pinion, *f*, upon the end of a shaft, K, which runs parallel with the axle.

Upon the other end of the shaft K is a cog-wheel, L, which gears with a pinion, *g*, on the end of the crank-shaft G, thus imparting the required motion.

Under the pickers I I is placed the plow or blade M, consisting of a V-shaped frame, with rods running back a suitable distance. This blade is attached to and supported by two upright bars, N N, secured at the rear end of the blade, and passing through guides O O in the frame. The bars N N are slotted where they pass through the guides, and a pin, *h*, is passed through said guide and slot.

To each of the bars N is secured a beam, P, which runs forward under the frame A and pivoted under the front end of the frame.

The upper ends of the bars N N are connected by a cross-bar, R, and a lever, S, pivoted on said cross-bar. The front end of this lever is, by rods *k k*, attached to the frame A, and by raising or lowering the rear end of said lever it follows that the plow or blade M is adjusted to any height desired, and the front ends of the beams P P are at the same time raised or lowered to correspond.

From the bars N N metal straps *m m* pass under the journal-boxes *e e* supporting the same, said boxes being thus adjusted by the adjusting of the blade M.

At the front ends of the beams P P are pivoted clevises *n n*, which are bolted to a cross-beam, T. To this beam the horses are to be attached by a double-tree in the center.

On the upper sides of the beams P P, near the front ends, is laid a cross-bar, V, on top of which the tongue W is hinged or pivoted.

From the upper side of the tongue W a bar, X, extends a suitable distance toward the rear, so as to rest upon the center of a shaft, Y, placed at the front end of the frame A, when the machine is in operation.

On the center of the shaft Y is a cam or projection, *p*, and at one end is a lever, Z. The tongue, being held by the horses in its proper position, the part of the machine in front of the axle is raised up from the ground by bearing down upon the lever Z, which causes the projection *p* to come under the rear end of the bar X. The lever Z is held in this position by a hook, *r*, on the frame A.

At a suitable point on each of the beams P is pivoted an arm, A', which extends forward and is adjusted at any suitable point by the slotted bar B', as shown in fig. 2.

The front ends of the arms A' form bearings for a shaft, upon which is placed a roller, C', and from the said arms rods *s s* extend outward, as seen in fig. 1.

On the under side of the cross-beam T are hinged scrapers D', four in number, two of which rest upon the shaft for the roller C', one on each side thereof, and the other two rest on the rods *s s*. The roller C'

and scrapers D' are for the purpose of pressing down and raking the weeds so as not to clog the pickers I I in rear.

Having thus fully described my invention,

What I claim as new, and desire to secure by Letters Patent, is—

1. The pickers I I, constructed as described, and operated by means of the crank-shafts G H, pinions *f g*, cog-wheels J L, shaft K, and axle B, substantially as set forth.

2. The combination, in a potato-digger, of the axle B, wheel C, with recessed hub, cap D, ratchet-wheel *a*, and spring pawl *b*, all substantially as and for the purposes herein set forth.

3. The arrangement, in a potato-digger, of the journal-boxes E E and *e e*, and straps *d d* and *m m*, for supporting and adjusting the crank-shafts G H, with the pickers I I, substantially as herein set forth.

4. The arrangement of the plow or blade, M, slotted bars N N, with beams P P, guides O O, cross-bar R, lever S, and rods *k k*, all substantially as and for the purposes herein set forth.

5. The arrangement, with frame A of the potato-digger, of the bar V, tongue W, bar X, shaft Y, projection *p*, and lever Z, all substantially as and for the purposes herein set forth.

6. The combination of the pivoted arms A' A', slotted bars B' B', roller C', and scrapers D' D', all substantially as and for the purposes herein set forth.

In testimony that I claim the foregoing I have hereunto set my hand and seal this 25th day of May, 1870.

JAMES DAVIS. [L. s.]

Witnesses:

G. F. WATSON,

J. H. DE RIDDER.