

(12) PATENT
(19) AUSTRALIAN PATENT OFFICE

(11) Application No. AU 199935149 B2
(10) Patent No. 752260

(54) Title
Strap-attached spur

(51)⁷ International Patent Classification(s)
A43C 017/02

(21) Application No: **199935149**

(22) Application Date: **1999.02.18**

(87) WIPO No: **WO00/01268**

(30) Priority Data

(31) Number	(32) Date	(33) Country
29811754	1998.07.03	DE
29811838	1998.07.06	DE

(43) Publication Date : **2000.01.24**

(43) Publication Journal Date : **2000.04.06**

(44) Accepted Journal Date : **2002.09.12**

(71) Applicant(s)
Herm. Sprenger GmbH and Co. KG

(72) Inventor(s)
Klaus Balkenhol

(74) Agent/Attorney
SPRUSON and FERGUSON,GPO Box 3898,SYDNEY NSW 2001

(56) Related Art
US 969839
US 5450712
US 1882059

35149/99



PCT WELTORGANISATION FÜR GEISTIGES EIGENTUM
Internationales Büro
INTERNATIONALE ANMELDUNG VERÖFFENTLICHT NACH DEM VERTRAG ÜBER DIE
INTERNATIONALE ZUSAMMENARBEIT AUF DEM GEBIET DES PATENTWESENS (PCT)

(51) Internationale Patentklassifikation ⁷ : A43C 17/02	A1	(11) Internationale Veröffentlichungsnummer: WO 00/01268 (43) Internationales Veröffentlichungsdatum: 13. Januar 2000 (13.01.00)
---	----	---

<p>(21) Internationales Aktenzeichen: PCT/DE99/00446</p> <p>(22) Internationales Anmeldedatum: 18. Februar 1999 (18.02.99)</p> <p>(30) Prioritätsdaten: 298 11 754.1 3. Juli 1998 (03.07.98) DE 298 11 838.6 6. Juli 1998 (06.07.98) DE</p> <p>(71) Anmelder (für alle Bestimmungsstaaten ausser US): HERM. SPRENGER GMBH & CO. KG [DE/DE]; Alexanderstrasse 10, D-58644 Iserlohn (DE).</p> <p>(72) Erfinder; und (75) Erfinder/Anmelder (nur für US): BALKENHOL, Klaus [DE/DE]; Höven 92, D-48720 Rosendahl (DE).</p> <p>(74) Anwalt: BAUER, Wulf; Bayenthalgürtel 15, D-50968 Köln (DE).</p>	<p>(81) Bestimmungsstaaten: AU, CA, JP, US, europäisches Patent (AT, BE, CH, CY, DE, DK, ES, FI, FR, GB, GR, IE, IT, LU, MC, NL, PT, SE).</p> <p>Veröffentlicht Mit internationalem Recherchenbericht.</p>
--	--

(54) Title: STRAP-ATTACHED SPUR

(54) Bezeichnung: SPORENBÜGEL MIT RIEMENBEFESTIGUNG

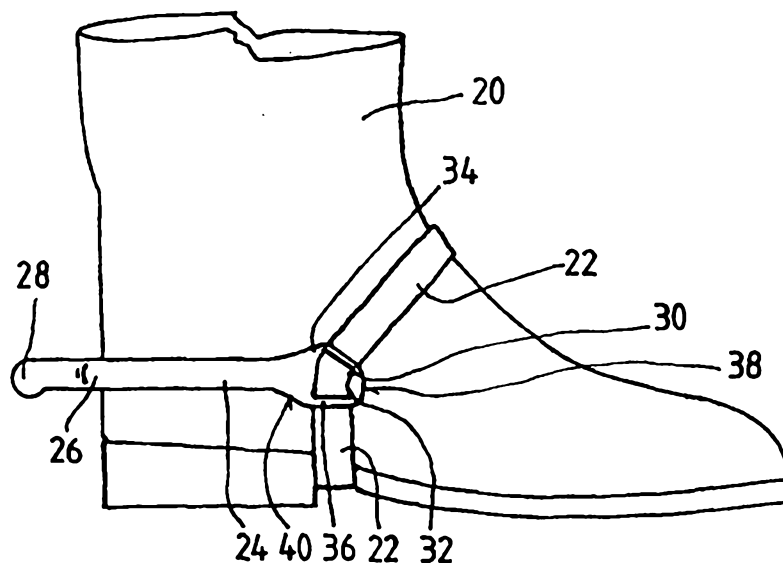

(57) Abstract

The invention relates to a strap-attached spur which is configured substantially U-shaped and has two lateral bars (24). Two spur strap eyelets (30, 32) are provided for in each free end of each bar (24) and receive a spur strap (22) of the strap attachment. The two spur strap eyelets (30, 32) of either end are not parallel but form an acute angle between each other.

SPR 4/98 PCT**Title: Strap-attached Spur**

The invention relates to a strap-attached spur which is configured substantially U-shaped and has two lateral bars, two spur strap eyelets being provided for in each free end of each bar, said spur strap eyelets receiving a spur strap of the strap attachment. Spurs of this type are used in horseback riding for example.

On the prior art spurs, the spur strap eyelets are parallel. This is irrespective of their concrete shape. The eyelets may indeed be given the shape of a long hole, i.e., with rounded end areas, the shape of oblong rectangles or the shape of a segment of a circle. According to the state of the art, they are always arranged in twofold symmetry.

This well known arrangement has some disadvantages however. In order to be able to fasten a spur to a rider's boot, one spur strap must be guided from the upper spur strap eyelets of each bar about the instep. Furthermore, the spur strap must be led from the lower spur strap eyelets of the spur straps and pass underneath the shoe and in front of the heel. The two directions of the spur strap however are not paralleled, they are rather positioned at an angle typically ranging between 30 and 60°. As a result, the spur strap warps on one side. It arches outward and only abuts with one longitudinal rim while gaping at the other longitudinal rim.

Usually, the two spur strap eyelets of each lateral bar are parallel to the direction of said lateral bar. In this event, although the spur strap is guided downward in a clean and correct manner, it does not fully rest on the boot toward the top, about the instep. Accordingly, it is not guided about the instep in the right position for use. As a result, it tends to slip. A correct fixation is not achieved. The inaccurate guiding is visible and disturbing as such.

Due to the parallel position of the two spur strap eyelets, the spur strap is unilaterally distorted by way of the front edge of the eyelet of the spur strap eyelet facing the free end of the lateral bar, the spur strap being distorted on

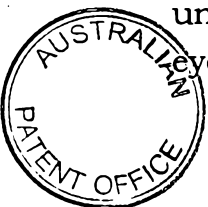

the side facing the boot and applying more force to this area, thus exerting a stronger local pressure onto the bones of the ankle. All this is unfavourable.

It is the object of the invention to avoid the drawbacks of the prior art spur mentioned above. It is also desirable to provide a spur which permits to guide in a clean,
5 fully fitting manner the upper area of the spur strap as well as the lower area of the spur strap.

The present invention provides a spur with a strap attachment, which strap attachment is attached to said spur, said spur having a substantially U-shaped form and having two lateral bars, each lateral bar having a free end, two spur strap eyelets
10 being provided for in each free end of each lateral bar, said spur strap eyelets receiving a strap of the strap attachment, the two spur strap eyelets of each end area are not paralleled but are inclined to one another at an angle, wherein a guide means for the strap is provided, said guide means being arranged in an area between the two spur strap eyelets of each lateral bar, said guide means allowing said strap to describe a curve and said
15 guide means tapering off toward a point at which the two spur strap eyelets of each lateral bar are farthest apart.

As a result and according to the preferred embodiment, the two spur strap eyelets of each lateral bar are oriented in such a manner that they are substantially positioned at right angles to the course of that area of the spur strap that originates in them. As a result
20 thereof, the strap rests with its whole surface on the boot (or on any other riding shoe). Thus, slipping is made more difficult. The strap is prevented from resting only at one side, thus strongly weighing on the bones of the foot. The overall aesthetic appeal is considerably enhanced. Tension is uniformly allotted to the two edge areas of the spur strap and no longer to only one side as it is the case with the spurs of the prior art. As a
25 result, the spur strap is easier to put on, it slides more readily through the spur strap eyelets.

According to the preferred embodiment, the spur strap eyelets of each lateral bar are relatively disposed in a V-shaped arrangement. The vertex of the V points toward the free end of each lateral bar. In other words, the distance between the two spur strap
30 eyelets increases when looking from the free end toward the base of the lateral bar.

The upper spur strap eyelet is inclined to the direction of the corresponding lateral bar at an angle of preferably between 5° and 120° , preferably between 5° and 80° , in particular at an angle from 20° of 60° . In so doing, the desired, optimal course is achieved, said course being practically at right angles to the longitudinal course of the spur strap.



Arching now no longer occurs outside the area of the two spur strap eyelets, but rather between them. Here though, it hardly irritates, and may additionally be absorbed by an appropriate guiding which reduces the upward slope of the arch and forms it into a suitable shape. Preferably, a

↓

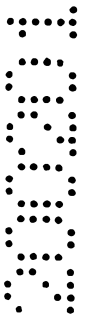
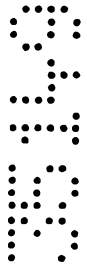

translation of the PCT-application

guide means for the spur strap is provided in that area in which the two spur strap eyelets of each lateral bar are farthest apart, said guide means allowing the spur strap to describe an inward or an outward curve and tapering off toward the point at which the two spur strap eyelets are closely adjacent.

In a preferred embodiment the two spur strap eyelets are long holes, that is, they are limited by two semicircular curves and by two straight lines. They may be any other shape however, and assume for example the shape of oblong rectangles, ovals or the like.

In a particularly preferred embodiment, the lateral bars are each provided with a curve in the end area of the upper instep strap eyelet. This curve substantially conforms to the shape of this upper instep strap eyelet. The lateral bars are thus given a particularly characteristic shape with aesthetic appeal which positively distinguishes them from the hitherto customary shapes. Furthermore room is made which is needed for the configuration of the upper instep strap eyelet.

Further advantages and characteristics of the invention will become apparent in the remaining claims and in the following description of an embodiment which is only an example and is not limiting the scope of the invention, said embodiment being explained in more detail with reference to the drawing.

FIG. 1: is a lateral view of a (partially illustrated) riding boot provided with a strapped spur in accordance with the invention,

FIG. 2: is a lateral view of the spur alone, without its strap, and

FIG. 3: is a top view of the spur of Figure 2.

A spur strapped by a spur strap 22 is attached to a riding boot 20 which is customary in trade and whose upper leg area is not shown in Figure 1. The spur strap is made of one piece and has a length of about 45 cm. As is conventional in this art, it has a fastener which cannot be seen in Figure 1 since it is located behind the boot and is typically made of braided synthetic threads or consists of a leather thong.



translation of the PCT-application

The spur is substantially U-shaped, it has two lateral bars 24 which are essentially built according to the same design principle. They are integral with a base part 26 from which a spur 28 in turn protrudes in opposite direction from the two lateral bars 24.

At the free end of each lateral bar 24 there is provided a head area in which two spur strap eyelets are located, viz., an upper spur strap eyelet 30 and a lower spur strap eyelet 32. Both eyelets are long holes which are limited by parallel straight lines and approximately semicircular end areas. In clear dimensions they are approximately 17 mm long and about 4mm wide in crosswise direction. These two spur strap eyelets 30, 32 are not paralleled, they are rather positioned at an angle which is of approximately 35° in the embodiment shown, but which can vary considerably about this value. The two spur strap eyelets 30, 32 are thereby arranged in such a way that they are located on the legs of a horizontal V whose vertex is located in the neighborhood of the free end of each lateral bar 24 and which accordingly widens toward the spur 28.

As shown in the Figures 1 and 2, the lower spur strap eyelet 32 runs parallel to the longitudinal direction of the corresponding lateral bar 24. Under normal wearing conditions and as also shown in Figure 1, said spur strap eyelet 32 accordingly runs parallel to a spur base supporting the boot. As more specifically shown in Figure 2, the head area of each lateral bar is thicker than the remaining part of said lateral bar. An upward curve 34 is provided which conforms to the contours of the upper spur strap eyelet 30, a lower extension 36 is furthermore provided which in turn also essentially conforms to the contours of the lower spur strap eyelet 32. Both spur strap eyelets 30, 32 terminate, on the front part for example, on a line which crosses the longitudinal direction of the lateral bars 24. The foremost, free edge 38 is designed accordingly and forms a right angle with respect to the longitudinal direction of the lateral bars 24.

The head area of the two lateral bars 24 assumes a very characteristic shape on account of the curve 34 and the lower extension 36, thus differing noticeably from the state of the art spurs.

The upper limiting edge of the lower spur strap eyelet 32 is substantially an extension of the lower edge of the corresponding lateral bar 24. The upper edge of the lateral bar 24 is extending undisturbedly toward the front and



translation of the PCT-application

intersects the upper spur strap eyelet 30 approximately in its center. The transitions from the undisturbed straight lateral bar 24 to the head area are adapted in their design so that an essentially roof-shaped tip is achieved in the upper part, and a slope 40 is obtained in the lower, said slope starting earlier however.

In order to compensate for an arching of the spur strap 22 which rests on the outer side of the spur in the area between the two spur strap eyelets 30, 32 (see Figure 1), the spur strap 22 is, in an improved embodiment, guided more strongly outward or inward at those places where material is abounding, that is in that area, where the two spur strap eyelets 30, 32 are very close. Here, a guide means sketched in dashed lines is provided in the form of an arch 42 that linearly tapers off toward zero in the direction of the area in which the two spur strap eyelets 30, 32 are farthest apart. When using braided spur straps 22, such an arch is less important than it is with leather thongs. The two spur strap eyelets 30, 32 can unite in their area facing the front end, which means that they may be joined together. In this case, a guide means may be designed in having the transition piece, which is located between the two spur strap eyelets 30, 32 and which terminates in a free end in this event, bending outward, said bend tapering off toward zero as well at the other lateral edge of the spur strap.



The claims defining the invention are as follows:

1. A spur with a strap attachment, which strap attachment is attached to said spur, said spur having a substantially U-shaped form and having two lateral bars, each lateral bar having a free end, two spur strap eyelets being provided for in each free end of each lateral bar, said spur strap eyelets receiving a strap of the strap attachment, the two spur strap eyelets of each end area are not paralleled but are inclined to one another at an angle, wherein a guide means for the strap is provided, said guide means being arranged in an area between the two spur strap eyelets of each lateral bar, said guide means allowing said strap to describe a curve and said guide means tapering off toward a point at which the two spur strap eyelets of each lateral bar are farthest apart.
2. Spur according to claim 1, wherein one of the two spur strap eyelets of each lateral bar is an upper spur strap eyelet, said upper spur strap eyelet being inclined to a direction of the corresponding lateral bar at an angle of between 5° and 120° .
3. Spur according to claim 2, wherein a longitudinal center line passing through the upper spur strap eyelet intersects a longitudinal center line of the corresponding lateral bar outside the upper spur strap eyelet on its side facing the free end.
4. Spur according to claim 1, wherein one of the two spur strap eyelets of each lateral bar is an upper spur strap eyelet, said upper spur strap eyelet having an upper area, and wherein a curve pointing upward when in use is provided about the upper area of the upper spur strap eyelet.
5. Spur according to claim 1, wherein one of the two spur strap eyelets of each lateral bar is a lower spur strap eyelet, said lower spur strap eyelet being essentially parallel to the corresponding lateral bar of the spur.
6. Spur according to claim 1, wherein the two spur strap eyelets of each lateral bar are essentially built according to the same design principle and are executed as long holes.
7. Spur according to claim 1, wherein one of the two spur strap eyelets of each lateral bar is a lower spur strap eyelet, said lower spur strap eyelet being inclined to a direction of the corresponding lateral bar at an angle of between 5° and 120° .
8. Spur according to claim 2 or 7, wherein the angle is between 5° and 80° ,
9. Spur according to claim 2 or 7, wherein the angle is between 20° and 60° .
10. Spur according to claim 1, wherein said curve is an inward curve.
11. Spur according to claim 1, wherein said curve is an outward curve.



12. A spur substantially as hereinbefore described with reference to the accompanying drawings.

Dated 16 February, 2001

Herm. Sprenger GmbH & Co. KG

Patent Attorneys for the Applicant/Nominated Person

SPRUSON & FERGUSON

5

2
R

5
5
5
5
5

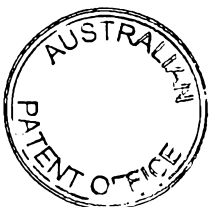

1 / 1

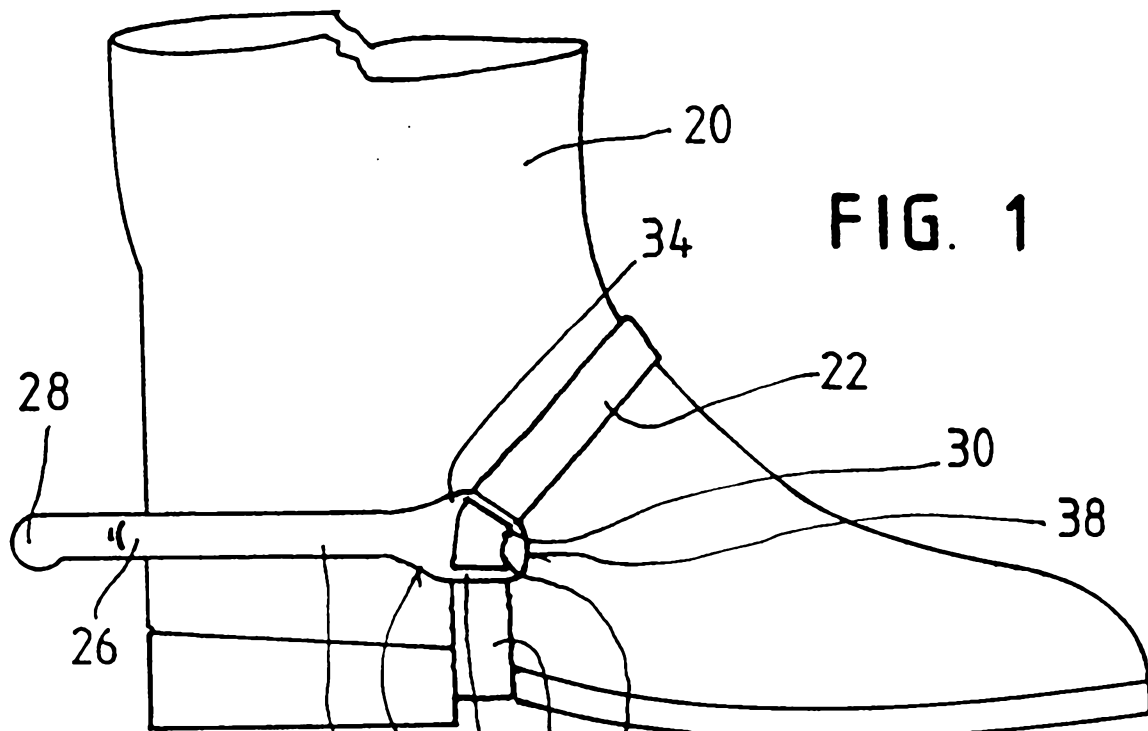

FIG. 1

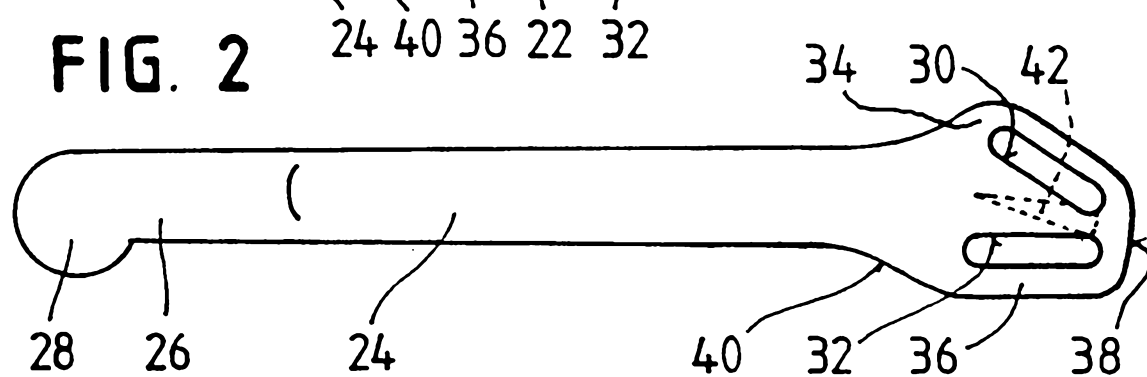

FIG. 2

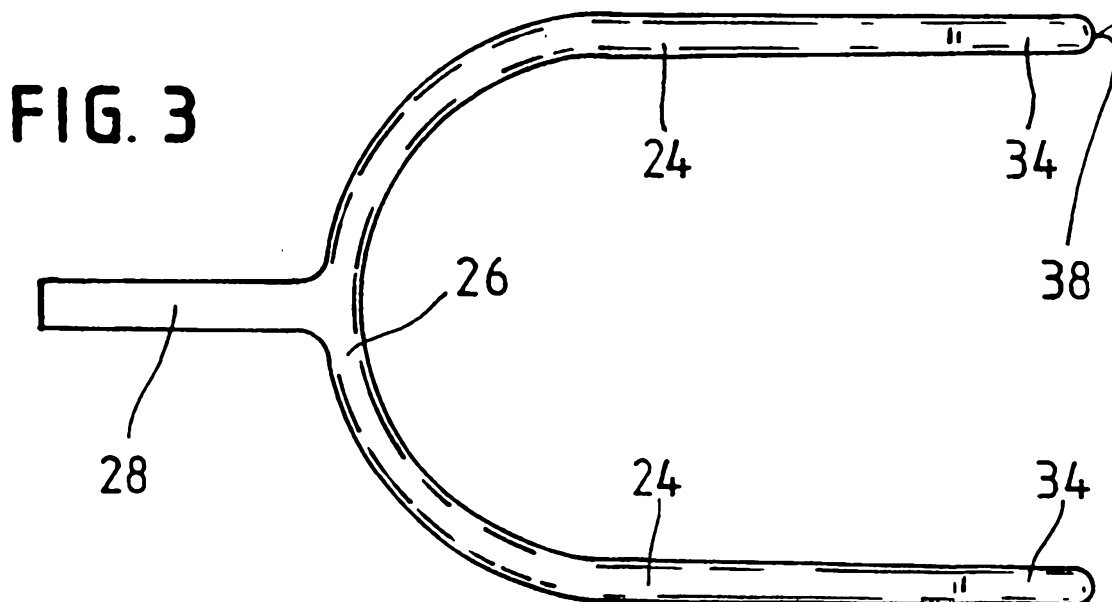

FIG. 3