

G. G. GILBERT.
WELL PLUG.

APPLICATION FILED MAY 3, 1915.

1,167,289.

Patented Jan. 4, 1916.

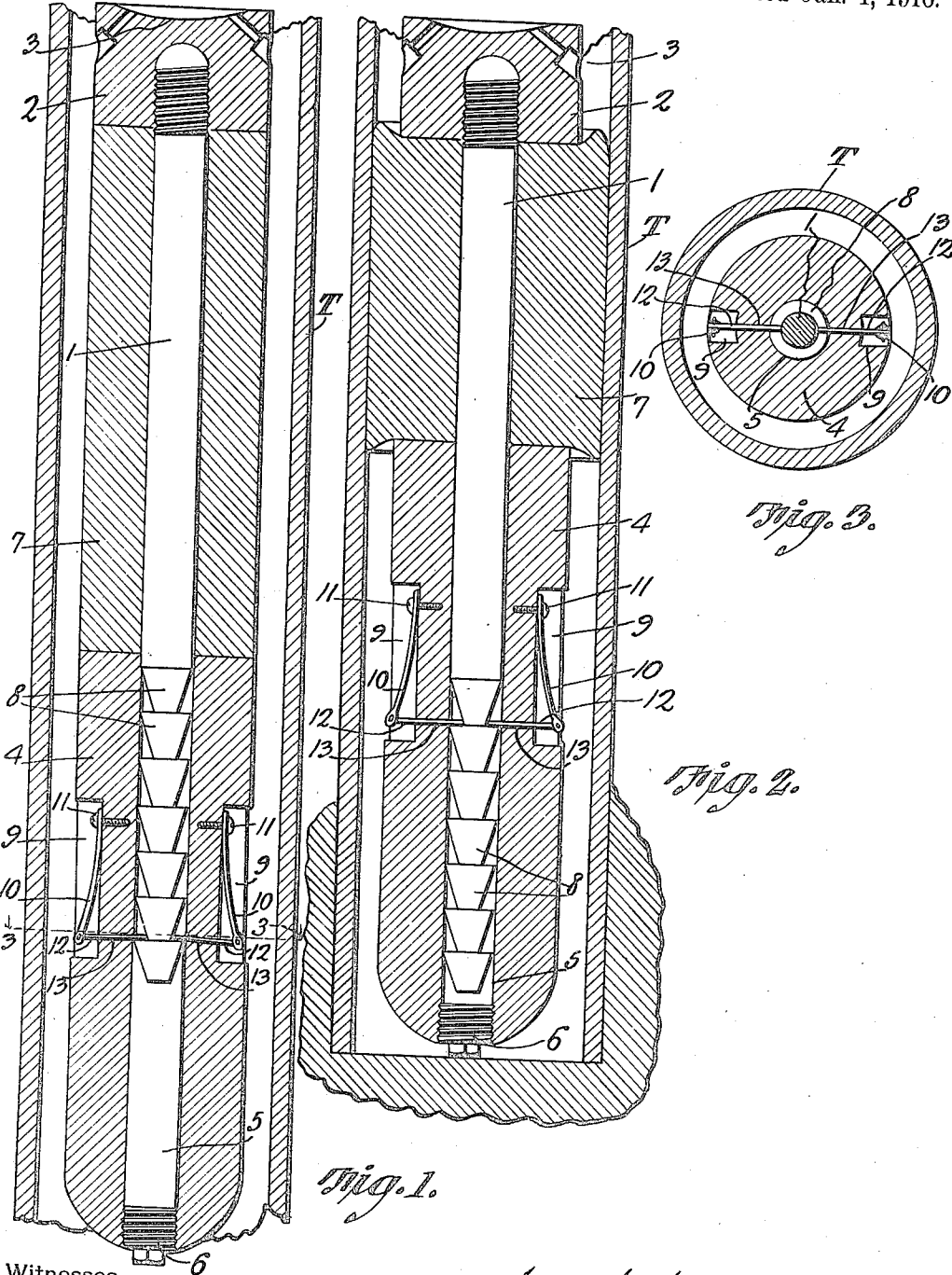

Witnesses

J. R. Loring
Amos E. Miller

Guy G. Gilbert Inventor
by *C. A. Snowles* Attorneys

UNITED STATES PATENT OFFICE.

GUY G. GILBERT, OF CUSHING, OKLAHOMA.

WELL-PLUG.

1,167,289.

Specification of Letters Patent.

Patented Jan. 4, 1916.

Application filed May 3, 1915. Serial No. 25,548.

To all whom it may concern:

Be it known that I, GUY G. GILBERT, a citizen of the United States, residing at Cushing, in the county of Payne and State of Oklahoma, have invented a new and useful Well-Plug, of which the following is a specification.

The present invention appertains to plugs for use in oil or similar deep wells, and aims to provide an expansible plug of novel and improved construction which may be lowered into the well and then acted upon for causing the plug to expand and close the lower end of the well.

It is not infrequently the case, in the drilling of oil wells, that the well is drilled too deep into the oil sand, in an effort to get a better flow of oil, and resulting in the striking of water below the oil bearing strata. It has ordinarily been the custom to fill up the well with dirt and rock up to the oil bearing strata, to prevent the flow of water upwardly from below the oil bearing strata. This method of shutting off the flow of water is not only inefficient, but also involves considerable trouble and time.

The present device is so constructed and designed that it may be lowered into the well whereby a drill or other suitable implement may be made to operate upon or hammer the plug for causing it to expand and thereby close the lower end of the well, to prevent the upward flow of water into the lower end of the well casing, should the well be drilled beyond the proper depth.

It is also within the scope of the invention to provide an expansible well plug of unique construction, to enhance the utility thereof, and whereby the same is comparatively simple, compact and inexpensive in construction, as well as being thoroughly convenient, practical and efficient in use.

With the foregoing and other objects in view which will appear as the description proceeds, the invention resides in the combination and arrangement of parts and in the details of construction hereinafter described and claimed, it being understood that changes in the precise embodiment of the invention herein disclosed can be made within the scope of what is claimed without departing from the spirit of the invention.

The invention is illustrated in the accompanying drawing, wherein:—

Figure 1 is a longitudinal section of the

plug in the condition in which it is arranged when lowered into the well. Fig. 2 is a longitudinal section of the plug in expanded position for closing the lower end of the well. Fig. 3 is a cross section taken on the line 3—3 of Fig. 1.

In carrying out the invention, there is provided a vertical rod or spindle 1, which has a head 2 of metal or other suitable material either integral with or threaded upon its upper end, the upper surface of the head 2 being concaved, as at 3, for receiving the blow of a drill or other implement dropped upon the plug, and whereby the drill or implement will be centered for properly transmitting the blow to the rod or stem 1. The head 2 may be apertured for the passage of a string for lowering the plug. The plug also includes a lower vertical tubular member or sleeve 4 having the longitudinal bore 5, the lower end of the bore 5 being closed by a cap 6 threaded or otherwise engaged into the lower end of the bore 5 for preventing water from flowing upwardly into the bore 5. The bore 5 receives the lower end of the rod 1, whereby the rod 1 and sleeve 4 are telescopically or slidably engaged to one another. The sleeve 4 is constructed of metal or other suitable material. The cap 6 can be replaced by a piece of pipe or a rod of suitable length to space the plug a suitable distance above the bottom of the well when desired.

Disposed upon the rod 1 between the head 2 and sleeve 4, is a compressible tubular member 7 of rubber or other equivalent material, whose ends abut against the head 2 and sleeve 4. The head 2, compressible member 7 and sleeve 4 are normally flush when the sleeve 4 and head 2 are separated, as seen in Fig. 1, with the parts in normal position.

The lower end portion of the rod 1 which fits slidably within the sleeve 4, is provided with a longitudinal series of frusto-conical portions 8 forming a rack whose shoulders face upwardly, and the sleeve 4 is provided at diametrically opposite sides with a pair of longitudinal recesses 9. Leaf springs 10 have their butt ends secured flatly, by means of screws or similar securing elements 11, within the upper ends of the recesses 9, and inwardly projecting pawls or dogs 12 are pivoted to the lower or free ends of the springs 10 and are slidable through slots 13

between the lower end portions of the recesses 9 and the bore 5. The pawls 12 cooperate with the portions 8 of the rod 1, to snap over the shoulders of the rod 1 under the influence of the springs 10 which tend to swing inwardly. The springs 10 and outer ends of the pawls 12 are housed within the recesses 9, so as not to project beyond the periphery of the sleeve 4. The recesses 9 may be covered in any suitable manner if desired.

In using the plug, the sleeve 4 and head 2 are normally separated, so that the compressible member 7 will be elongated, as seen in Fig. 1, and the plug may then be readily lowered into the well T, the head 2, member 7 and sleeve 4 of the plug being smaller than the internal diameter of the well T, and the lower end of the sleeve 4 being tapered or rounded in order that same may readily descend within the well. When the plug strikes the lower end of the well, the plug may be expanded for closing the lower end of the well. To this end, a drill or other suitable implement is lowered down in the well by means of the usual cable, and is reciprocated so as to hammer the head 2 downwardly and this will cause the member 7 to be compressed longitudinally, and expanded laterally so as to increase its diameter, as seen in Fig. 2, and whereby the member 7 will bear against the walls of the well and close the lower end of the well and shut off the water. During the time that the head 2 is being driven downward, the rod 1 will be moved downwardly therewith, and the spring pressed pawls 12 will snap over the shoulders of the rod 1, to

hold the head 2 depressed and the member 7 expanded.

With the present device, it is a simple and convenient matter for the operator to plug up the lower end of the well and shut off the water in a thoroughly practical and efficient manner. It will also be noted that the present device is simple in construction, whereby it may be readily and inexpensively manufactured, and the present plug is of advantage for other obvious reasons.

Having thus described the invention, what is claimed as new is:—

A well plug comprising a head, a sleeve, a rod having one end engaged to the said head and having its other end portion slidably received by said sleeve, the last mentioned end portion of said rod having a longitudinal series of frusto-conical portions providing a rack within said sleeve, a compressible member between the head and sleeve adapted to be expanded when the head and sleeve are moved toward one another, the sleeve having diametrically opposite longitudinal recesses and slots between said recesses and the bore of the sleeve, leaf springs having their butt ends secured flatly in said recesses, and pawls pivoted to the free ends of the leaf springs and slidable through said slots to engage said rack.

In testimony that I claim the foregoing as my own, I have hereto affixed my signature in the presence of two witnesses.

GUY G. GILBERT.

Witnesses:

H. T. CARVER,
JACOB PUCKETT.