

(19)



(11)

EP 1 809 548 B1

(12)

EUROPEAN PATENT SPECIFICATION

(45) Date of publication and mention of the grant of the patent:
26.04.2017 Bulletin 2017/17

(51) Int Cl.:
B65D 47/00 (2006.01) B65D 51/16 (2006.01)

(21) Application number: **05796807.5**

(86) International application number:
PCT/IL2005/001067

(22) Date of filing: **07.10.2005**

(87) International publication number:
WO 2006/038216 (13.04.2006 Gazette 2006/15)

(54) DRINKING CONTAINER, VENT SYSTEM AND METHOD

TRINKBEHÄLTER, LÜFTUNGSSYSTEM UND -VERFAHREN

RECIPIENT POUR BOIRE, PROCÉDÉ ET SYSTÈME DE MISE À L'ATMOSPHÈRE

(84) Designated Contracting States:
AT BE BG CH CY CZ DE DK EE ES FI FR GB GR HU IE IS IT LI LT LU LV MC NL PL PT RO SE SI SK TR

• **Tirosh, Tamir**
14945 Menahemia (IL)

(30) Priority: **08.10.2004 US 617375 P**

(74) Representative: **Modiano, Micaela Nadia et al**
Modiano Josif Pisanty & Staub Ltd
Thierschstrasse 11
80538 München (DE)

(43) Date of publication of application:
25.07.2007 Bulletin 2007/30

(56) References cited:
WO-A-2004/075810 GB-A- 2 167 735
KR-A- 2003 060 185 US-A- 5 720 555
US-A- 5 749 483 US-A- 5 779 071
US-A1- 2004 089 626 US-B1- 6 361 746

(73) Proprietor: **CORALINDA TRADING CORP**
8001 Zurich (CH)

(72) Inventors:
 • **Berkovitch, Amikam**
Shenley, Hertfordshire, WD7 9LG (GB)

EP 1 809 548 B1

Note: Within nine months of the publication of the mention of the grant of the European patent in the European Patent Bulletin, any person may give notice to the European Patent Office of opposition to that patent, in accordance with the Implementing Regulations. Notice of opposition shall not be deemed to have been filed until the opposition fee has been paid. (Art. 99(1) European Patent Convention).

Description

[0001] This Application claims the benefit of United States Provisional Patent Application No. 60/617,375 filed October 8, 2004.

Field of the Invention

[0002] The present invention relates to a drinking container and method of providing flow through the container for use with leak resistant and non-spill containers, such as toddler drinking cups and baby bottles.

Description of Related Art

[0003] Specialized baby bottles are manufactured with features that are designed to attempt to reduce colic symptoms in infants from zero months to approximately four months. Notably, United States Patent Nos. 5,570,796 and 5,779,071 state that their designs eliminate the mixing of air into the formula as this increases the risk of colic symptoms. Also, a bottle that requires a child older than four months to exert too much "sucking" action on the nipple of the bottle may result in an increased likelihood of the child developing an ear infection.

[0004] The apparatus described in United States Patent Nos. 5,570,796 and 5,779,071 includes a reservoir tube having a tube portion in combination with a reservoir, which acts as a liquid trap. An insert used in conjunction with the reservoir tube provides passage for air from the exterior of a bottle to the interior of the bottle. When the bottle incorporating the features of these patents is fully inverted, the reservoir (liquid trap) contains the liquid from inside the reservoir tube, and prevents the liquid from entering an opening of the insert, since the opening of the insert is above the level of the liquid contained in the reservoir. It is important to note that the volume of the reservoir is larger than the volume of the tube portion, and thus, the liquid may be fully contained in the liquid trap under a narrow window of operating conditions. However, the bottle cannot be filled with liquid that would reach higher in the bottle than the opening of the insert since, when the bottle is inverted, liquid would go directly into the air vent.

[0005] On the other hand, since these bottles are fully vented, when turned upside down, liquid flows freely through the liquid outlets, without the need for sucking by a baby. This can be problematic as the liquid spills freely if the bottle is tilted, and even if the baby falls asleep, the liquid keeps flowing, which can cause the child to choke.

[0006] Furthermore, the apparatus described in United States Patent Nos. 5,570,796 and 5,779,071 require detailed cleaning of their many needed parts and accessories. Unfortunately, many of the parts have interior and remote regions requiring cleaning with a modified pipe cleaner or the like. Even with such measures, it is difficult

to ensure that the interior regions are clean, and most caretakers are not interested in such a detailed and extensive cleaning protocol. In addition, it is difficult to visually inspect the interior regions to ascertain their cleanliness.

[0007] Moreover, the apparatus described in United States Patent Nos. 5,570,796 and 5,779,071 suffer from leakage when the bottle is overfilled since then the reservoir tube and the liquid trap described therein become filled with liquid beyond the capacity of the liquid trap, allowing liquid to enter the insert and eventually to the exterior of the bottle. Additionally, the apparatus described in these patents suffers from leakage when the bottle is squeezed, if the nipple attached to the bottle is squeezed, when the bottle is shaken to mix a formula, if the liquid is heated to above 45°C, or if the bottle is subjected to changes in atmospheric pressure, as liquid can flow out through the air inlet passages in these cases, as well.

[0008] One solution to some of these problems is shown in PCT publication WO 2004/075810 to Pyun. This application describes a nursing bottle having an air intake unit for allowing external air to be introduced into a body of the nursing bottle while adjusting the amount of external air introduced into the body. The air intake unit includes upper and lower partition plates, and an air inlet tube. The top partition plate includes an air inlet slot and is formed of plastic while the bottom partition plate, which serves to cover and complete the air inlet slot, is made of silicon and equipped with a first check valve for preventing milk from flowing backwards through the air passage. This structure is problematic in that, under pressure applied to close the nipple onto the air inlet unit, the silicon of the bottom plate may deform so as to fill or partially block the air inlet slot in the upper plate, thereby interfering with the free flow of air into the bottle.

[0009] The air inlet tube is coupled to a bottom surface of the lower partition plate in such a manner that air introduced into the air intake slot of the upper partition plate is introduced into the body of the bottle when external suction force is applied to the air inlet tube. A second check valve is coupled to the air inlet tube. The first check valve permits air to enter the bottle, and the second permits steam and hot gases to escape from the bottle. Thus, although the Pyun publication states that the second check valve is for preventing milk from flowing backwards, it cannot do so alone since it opens in the direction of the air intake slot to permit the release of hot gases. In practice, the air inlet tube serves to prevent leakage of liquid through the second valve, as it acts as a liquid reservoir, as in the patents described above. Thus, this device cannot be used without the air inlet tube, as liquid would flow out through the air inlet slot.

[0010] It is also known from GB 2 167 735 a teat for a feeding bottle that includes, in addition to the normal orifice, an extra orifice. The orifice includes a one way valve through which air may pass into the feeding bottle so that the pressure within the bottle remains at substantially

atmospheric pressure.

[0011] The present invention relates to a drinking apparatus comprising a vent system that removably connects to a bottle or a drinking container. The vent system has the features set forth in claim 1.

[0012] Multiple embodiments for a base portion of the vent system are described herein, including an embodiment with a duck-bill valve.

[0013] An optional anti-bubble tube may be used with the vent system. The anti-bubble tube provides for air entering the inverted container to reach an air pocket formed in the bottom portion of the container which, during the use of the container, is raised above a nipple or a spout of the container. The air pocket is created by the emptying of the container through the nipple or the spout by the user. By providing passage for the air directly to the air pocket, the incoming air is not allowed to mix with the liquid in the container and create air bubbles in the liquid.

[0014] The vent system may be used in a variety of leak resistant and essentially nonspill drinking containers, such as toddler drinking cups, baby bottles, adult sport drink containers, and other drinking containers. It will be appreciated that the optional anti-bubble tube is only for use in baby bottles, and other containers with the vent system of the invention provide leak resistant and non-spill containers even without the tube.

[0015] The vent system, the anti-bubble tube and the valve together act as a "diving bell", and generally prevent liquid from entering the anti-bubble tube when the drinking container is in a substantially upright position. This is due to the fact that air is trapped in the anti-bubble tube with no escape until the valve is opened, i.e., the trapped air acts as a barrier preventing liquid from entering the anti-bubble tube. The diving bell effect is created by the user of the container when the user places the vent system (with the anti-bubble tube attached) into the container. The diving bell function allows the user to vigorously shake the container without leakage or to fill the container with boiling water without leakage. The container may also be completely filled with liquid, i.e., the container may be filled without limitation.

[0016] When the container is inverted and liquid exits from the container, as soon as a vacuum force is created inside the container, the valve is opened and air enters the container. As air is drawn into the container, the valve releases the "new" air into the anti-bubble tube and into the volume of trapped air. This "new" air may displace some of the trapped air, thus forcing the trapped air through the anti-bubble tube. In this position, the "diving bell" effect is not maintained in the anti-bubble tube. In any event, the anti-bubble tube is shaped and coupled to the base portion of the vent system in such a way as to allow only a small amount of liquid to enter the anti-bubble tube. Thus, the liquid generally does not cover the valve. However, even if liquid covers the valve, the valve prevents the liquid from entering the air inlet channels of the vent system and, despite the absence of the

diving bell effect, the bottle still operates in a leak-free manner.

[0017] The optional anti-bubble tube is important for use by newborns, since they are at a greater risk for developing colic symptoms from swallowing air. However, as infants grow, this invention allows the user to remove the anti-bubble tube and still retain a leak resistant vent system.

[0018] The vent system allows an infant drinking from a bottle of the present invention to easily drink from a nipple or spout attached to the bottle without appreciably increasing the vacuum force inside the bottle. At the same time, the valve of the vent system reduces the likelihood of leakage of liquid from the bottle via the vent system when the bottle is in an inverted or sideways position, since the valve prevents the flow of liquid into the vent system. The valve is designed such that increased exertion to create a high degree of suction force is not necessary for liquid to flow from the bottle and, thus, the risk of causing a middle ear infection in the user from such over exertion is reduced. On the other hand, suction is required in order to provide liquid outflow, which simulates breast feeding and prevents spilling of the liquid when the bottle or container is upside down.

[0019] According to the present invention, a small quantity of liquid exits the container through the nipple or spout when the container is inverted or placed at an angle, creating a minimal vacuum force in the container. When a child sucks on the nipple or spout, the vent system provides venting to the atmosphere surrounding the container and provides for operation with minimal vacuum. This minimal vacuum force created in the container of present invention as the liquid is exiting the container draws air into the container from the surrounding atmosphere until equilibrium between the atmosphere and the interior of the container is created. Thus, the container of the invention requires an added sucking force to be applied by the user of the container to receive liquid from the container which may emulate the process of breast feeding. However, no appreciable vacuum force is created in the container during use of the container due to the venting..

[0020] As used herein, "leak free" means that the container is free from leaks through the vent system. Since the vent system provides venting, the valve is necessary to prevent leakage therethrough. All of the embodiments of the present invention operate in a leak free manner.

[0021] As used herein, "non-spill" refers to spillage via the nipple or the spout of the container. Certain embodiments of the present invention operate in a non-spill manner.

[0022] The vent system of the present invention is particularly simple to clean, since the base portion and the disc portion do not include interior or remote regions that are inaccessible without specialized cleaning equipment. Rather, all regions of the base portion and the disc portion are readily accessible. Thus, the vent system provides full access to various components of the vent system for

cleaning. Additionally, the various components of the vent system may be visually inspected for cleanliness.

[0023] The vent system of the present invention attaches to certain readily available containers in the baby bottle industry. In other embodiments of the present invention, the vent system may be used in conjunction with a "sippy cup" and spout for use by toddlers. The sippy cup may also include a flexible spout. In addition to baby bottles and sippy cups, the apparatus of the present invention may be used with non-spill containers for people of all ages. For example, bicyclists and other athletes and sports participants may benefit from using a substantially leak-free, non-spill container.

Brief Description of the Drawings

[0024] The present invention will be further understood and appreciated from the following detailed description taken in conjunction with the drawings in which:

Figure 1 is a sectional view of a bottle having a vent system constructed and operative in accordance with a first embodiment of the present invention.

Figure 2 is a sectional view of the vent system according to the first embodiment.

Figures 3(A) - 3(D) are views of the base portion of the first embodiment.

Figures 4(A) - 4(E) are views of the disc portion.

Figure 5 is an exploded view of the vent system of the first embodiment.

Figures 6(A) - 6(D) are views of the vent system of the first embodiment.

Figure 7 is a sectional view of a bottle having a vent system constructed and operative in accordance with a second embodiment of the present invention.

Figure 8 is a partial sectional view of the bottle incorporating the vent system of the second embodiment.

Figures 9A - 9D are view of the base portion of a second embodiment of the invention.

Figure 10 is an exploded view of the vent system of the second embodiment.

Figures 11A-11D are assembled views of the disc portion, the base portion of the second embodiment, and the anti-bubble tube.

Figure 12 is a sectional view of a sippy cup having a vent system constructed and operative in accordance with an embodiment of the present invention.

Detailed Description of the Preferred Embodiments

[0025] The present invention is directed to a vent system that may be used to provide leak resistant drinking containers, such as a baby bottle, a sippy cup, sports bottles, or other non-spill drinking vessels used by adolescents and adults. The present invention also relates to a drinking apparatus comprising a vent system that removably connects to a bottle or a drinking container.

The vent system includes a disc portion and a base portion for closing the drinking container. The disc portion and the base portion operate together to allow liquid to flow to a nipple or a spout of the container and to also allow air to enter the container. The base portion includes a one-way valve, integrally formed with the base portion. The valve includes an opening to allow air to pass from the atmosphere surrounding the drinking container to the interior of the drinking container. This allows liquid to freely flow from the container under minimal vacuum, without the user applying more suction force than in breast feeding. The vent system is designed such that increased exertion to create a high degree of suction force is not necessary for liquid to flow from the bottle, and thus the likelihood of causing an ear infection in the user from such over exertion is reduced. At the same time, the valve prevents liquid from the interior of the drinking container from leaking out through the vent system.

[0026] An optional anti-bubble tube may be used with the vent system, to provide for air entering the inverted container to reach an air pocket formed in the bottom portion of the container during use of the container. By providing a passage, via the antibubble tube, for the air directly to the air pocket, the air is not allowed to mix with the liquid in the container and create air bubbles in the liquid.

[0027] The vent system removably connects to a bottle or other drinking container. Generally, the vent system is held into or onto the drinking container via a collar. The disc portion and the base portion are complimentary in shape and cooperate to form the air vent channels that merge into the valve, and provide an air passage into the container from the atmosphere surrounding the drinking container via the space between the container and the collar.

[0028] The vent system is easily assembled and disassembled by the user. Importantly, the base portion and disc portion, when disassembled, are easily cleaned, since nearly all of their surfaces which form the air vent channels and liquid openings are fully accessible and may be cleaned without any specialized equipment.

[0029] Multiple embodiments for the base portion are described herein. In general, the base portion comprises the valve, a plurality of base liquid openings, and a plurality of base vent channels. The base vent channels are a grooved or a recessed portion of the base portion extending between the valve and the periphery of the base portion where vent channel openings are located. The valve is essentially hollow and includes an opening or slit that provides passage for air into the interior of the container. The valve communicates with the base vent channels to allow air to enter the container from the exterior. When the disc portion is placed on the base portion, the air vent channels are fully defined by the base vent channels and a bottom surface of the disc portion, and, thus, the air vent channels are sealed from the liquid openings. The disc portion is formed of a substantially rigid material, while the base portion is formed of silicon or other flexible,

sterilizable material, so the base vent channels cannot be blocked by the disc portion.

[0030] The exact shape and structure of the base liquid openings may vary so long as they provide for the liquid to flow from the drinking container to the nipple and allow the vent system to operate. The shape of the base liquid openings may be, for example, triangular, ovular, or kidney-shaped. The base liquid openings are defined by throughgoing base liquid opening channels that extend through the base portion.

[0031] The disc portion also comprises a plurality of disc liquid openings to allow liquid to pass to the interior of the nipple. The plurality of disc liquid openings cooperate with the plurality of base liquid openings to create the liquid openings. The base liquid openings and the disc liquid openings are preferably complimentary in shape and arranged such that the disc liquid openings seat inside the base liquid openings. The complimentary shape of the base liquid openings and disc liquid openings provides stability to the vent system and seals liquids from the air vent channels. This sealing prevents liquids from entering the air vent channels and reduces leaking.

[0032] According to one embodiment of the invention, each disc liquid opening includes a descending member that defines the disc liquid opening and extends below a bottom surface of the disc portion. This descending member is received by the base portion, i.e., the descending member seals flush against the base liquid opening channels of the base member. This sealing of the complementary disc liquid opening and the complementary base liquid opening stabilizes the disc portion on top of the base portion and prevents liquid from entering the air vent channels.

[0033] The present invention will now be described with reference to **Figure 1**, which shows a drinking apparatus including a container **200** incorporating a vent system **215** constructed and operative in accordance with a first embodiment of the present invention. In the illustrated embodiment, container **200** is a baby bottle, although one of ordinary skill in the art may adjust the dimensions of vent system **215** to fit a larger sippy cup container or to an even larger adult sized drinking container. Vent system **215** comprises a base portion **305** and a disc portion **310**. The vent system **215** provides for air to enter the container **200** to compensate for the liquid exiting the container and thus prevent more than a minimal vacuum from forming within the container **200**.

[0034] A collar **225** screws down over the top of the vent system **215** and around a neck **205** of the container. The collar **225** holds a nipple **230** in place on top of the vent system **215**. A nipple flange **231** may be squeezed by the collar **225** to seal the nipple against disc portion **310** of vent system **215**. In the alternative, a lid with a flexible spout, or any other suitable dispensing device, may be used instead of the nipple **230**.

[0035] This embodiment of the present invention will now be discussed with particular reference to **Figures 2-4**, which show the main components of the vent system

215, namely the base portion **305** and the disc portion **310**.

[0036] As seen in **Figure 2**, the vent system **215** includes the disc portion **310** and the base portion **305**. Disc portion **310** is substantially rigid. Disc portion **310** and base portion **305** cooperate to form air vent channels **335** leading from air vent openings **330** in the exterior of vent system **215**. The air vent channels **335** merge into a uni-directional valve **700** having an opening or a slit **715**, such that air may pass from outside of the container through the vent channel openings **330**, through the air vent channels **335**, through the valve **700**, through slit **715** of the valve and into the container **200**. Air from the outside may pass between the threads of the collar and the threads on the exterior of the baby bottle or the sippy cup container to the vent channel openings **330**.

[0037] The vent system **215** also includes liquid openings **400**. The liquid openings **400** allow the fluid in the container, such as the formula, juice, milk, etc., to pass from the bottle or sippy cup through the vent system **215** and to the nipple or the spout. The liquid openings **400** may be of any shape so long as they provide rigidity to the vent system **215** and provide for the fluids to pass through the liquid openings **400**.

[0038] With reference to **Figures 3A to 3D**, the base portion **305** of the vent system **215** is illustrated in detail. Base portion **305** includes an outer ring **505** and an inner ring **510**. The inner ring **510** fits inside of the container **200**, while the outer ring **505** sits on a top lip **520** (shown in **Figure 1**) of the container **200**. Preferably, inner ring **510** is slightly angled to the periphery of the first base portion **305** to create a seal against the inside of the container **200**.

[0039] Base portion **305** is formed with base vent channels **415**. The base vent channels **415** are a grooved or a recessed portion of the base portion **305** that create a channel for air to enter the base portion and ultimately to the valve and the interior of the container. It is a particular feature of the invention that base portion **305** with base vent channels **415** is integrally formed with valve **700**, preferably of silicon or other flexible and sterilizable material.

[0040] Base portion **305** also includes a plurality of base liquid openings **425**. In this embodiment, the base liquid openings **425** are defined by base liquid opening channels **450** that extend through the base portion **305** below a top surface **370** of the base portion **305**. The base liquid opening channels **450** have a tubular shape.

[0041] Integrally formed with base portion **305** is a one-way valve **700**. The valve **700** allows air to enter the bottle to prevent more than a minimal vacuum from forming, but it does not allow liquid to exit the bottle via the vent system **215** and create a leak. The valve **700** includes a valve opening **715** opening into the container as soon as a minimal vacuum is created inside the container. The valve **700** is integral to the first base portion **305**, i.e., the first base portion **305** and the valve **700** are formed as a single unit. At a junction between the valve **700** and the

remainder of the base portion **305**, the base portion includes an indented region **720** (shown in **Figure 5B**) for an optional anti-bubble tube **800**, described in detail below, to circumscribe and attach to the base portion **305**.

[0042] The disc portion **310** according to one embodiment is illustrated in detail in **Figures 4A to 4E**. Disc portion **310** includes a planar lower surface **371** adapted to sealingly engage a top surface of base portion **305**. Extending through disc portion **310** are a plurality of disc liquid openings **430**. Each disc liquid opening **430** includes a descending member **431** that defines the disc liquid opening **430** and extends below the lower surface **371** of the disc portion **310**. This descending member **431** of the disc portion **310** is received by the base portion **305**. The descending member **431** seals against a surface **451** of the base liquid opening channels **450** of the base portion **305**. This also stabilizes the disc portion **310** on top of the base portion **305**.

[0043] Assembly of the vent system **215** is shown in **Figure 5**. As can be seen, disc portion **310** is placed over base portion **305** with disc liquid openings **430** in registration with base liquid openings **425**. An optional anti-bubble tube **800** may be provided, as shown in this embodiment. At a junction between the valve **700** and the remainder of the first base portion **305**, the base portion may include an indented region **720** for anti-bubble tube **800** to circumscribe and attach to the base portion **305**. The anti-bubble tube **800** extends to nearly the bottom portion of the container **200** and includes an anti-bubble tube opening **815**, which provides an outlet for the air from the valve **700** to the interior of the container **200**.

[0044] The anti-bubble tube **800** comprises a tubular structure that seals the region surrounding the valve **700** and vents through the anti-bubble tube opening **815**. The anti-bubble tube **800** is shown comprised of an upper section **840** and a lower section **850**, which includes the anti-bubble tube opening **815**. The upper section **840** surrounds the valve **700** and the lower section **850** extends nearly the length of the container **200**. The anti-bubble tube **800** is a conduit for air from the valve **700** to reach an air pocket formed in the bottom portion of the inverted container **200** during drinking from the container **200**, without mixing with the liquid or creating bubbles in the liquid. The volume of the lower section **850** is greater than the volume of the upper section **840**. In use, this means that upper section **840** does not serve as a liquid reservoir, so liquid entering the anti-bubble tube from the container may cover the valve opening **715**. However, since valve **700** is a one-way valve, no liquid can pass through opening **715** into the air inlet channels. Thus, it will be appreciated that a container with the venting system of the present invention can fulfill its function of introducing air to the container during drinking and preventing leakage through the air inlet passages with or without the anti-bubble tube.

[0045] The assembled vent system according to one embodiment of the invention with an anti-bubble tube is

illustrated in **Figures 6A to 6D**. The air vent channels **335** are formed when the disc portion **310** is placed on base portion **305**. The lower surface **371** of disc portion **310** covers base vent channels **415** and forms and seals a top portion of the air vent channels **335**. It is a particular feature of the invention that the disc portion is substantially rigid plastic, while the base portion, including the base vent channels, may be formed of silicon. Thus, even under pressure of the cap, the disc portion cannot be deformed so as to block the vent channels in the base. The base vent channels **415** are fully accessible for cleaning when the disc portion **310** is removed.

[0046] In use, air passes in between a threaded region **500** of the neck **205** of the container and a threaded region **501** of the collar (shown in **Figure 1**) and enters vent channel openings **330** (shown in **Figures 1 and 6(A) - (D)**) of the vent system **215**. This may be accomplished by designing each threaded region such that there is sufficient space for the air to exit or, in the alternative, by creating notches or gaps in the threaded region to provide for air flow.

[0047] The liquid openings **400** allow the fluid to pass from the container. The liquid openings **400** are formed by a combination of base liquid openings **425** and disc liquid openings **430**. The base liquid openings **425** and the disc liquid openings **430** may vary in structure, although preferably they are complementary to one another.

[0048] Referring now to **Figures 7 and 8**, there is shown a drinking container, here illustrated as a baby bottle, with a vent system **216** constructed and operative in accordance with an alternative embodiment of the invention. Vent system **216** includes a disc portion **310**, identical to that discussed above, and a base portion **306**. The vent system **216** functions in the same general manner as the vent system **215**, and is shown with the container **200**, the nipple **230**, the collar **225**, and the anti-bubble tube **800** illustrated above with the vent system **215**. The vent system **216** includes liquid openings **401** to pass fluids to the nipple **230**.

[0049] Integrally formed with base portion **306** is a one-way duck-bill valve **701** and a tab **900**, as shown most clearly in **Figures 9A to 9D**. The duck-bill valve **701** is sensitive to fluctuations in pressure. The tab **900** provides the user a region to grasp on the base portion **306** when pulling or removing the anti-bubble tube **800** from the base portion **306**. The tab **900** includes ridges **910** to provide a frictional gripping surface. In use, or during cleaning, the base portion **306** may be covered in a fluid such as milk or a cleaning solution, and it is helpful for the user to have the tab **900** to grasp and ease the removal of the anti-bubble tube from the base portion **306**.

[0050] The incorporation of the duck-bill valve **701** into the base portion **306** provides a more sensitive valve. The duck-bill valve **701** has a slit **716** that forms an opening to allow air to enter the anti-bubble tube **800** and eventually into the container **200**. The slit **716** has a generally linear shape which, preferably, is positioned in a

direction generally perpendicular to the air entering the duck-bill valve **701** and pushing against the slit **716**. This relationship promotes the sensitivity of the duck-bill valve **701**. The duck-bill valve **701** is very sensitive to pressure and will open with only a few drops of liquid leaving the container **200** allowing air to enter the container **200**. When liquid is no longer leaving the container **200**, the duck-bill valve **701** closes fast to prevent leakage via the vent system **216**. Also, the duck-bill valve **701** is open on its top side and will allow easy cleaning, since a cleaning solution may easily be introduced into the duck-bill valve **701**.

[0051] Base portion **306** also includes integrally formed base vent channels **416** leading from air vent openings **331**. The base vent channels **416** (shown in **Figures 9A** and **9B**) are a grooved or a recessed portion in the top surface of the base portion **306** that create a channel for air to enter the base portion **306** from outside the container into the valve and thence to the interior of the container.

[0052] Base portion **306** also includes a plurality of base liquid openings **426**. The base liquid openings **426** are defined by base liquid opening channels **452** that extend through the base portion **306**. The base liquid opening channels **450** have a tubular shape to permit the free flow of liquid therethrough and are complementary to disc liquid openings **430** in the disc portion **310**.

[0053] As seen in **Figures 10** and **11A-11D**, disc portion **310** and base portion **306** cooperate to form the vent system **216**. Air vent channels **336** are formed by placing the planar lower surface of disc portion **310** over base vent channels **416** of the second base portion **306**, as described above. Air vent channel openings **331** permit air to enter the air vent channels **336**. The air vent channels **336** merge into the uni-directional duck-bill valve **701** to allow air to enter the container **200** when minimal vacuum is formed in the container.

[0054] The base liquid openings **426** and the disc liquid openings **430** of the disc portion **310** are complementary and their joining stabilizes the vent system **216**. In particular, the descending member **431** of the disc portion **310** seals against a surface **436** of base liquid opening channels **452** of the second base portion **306**. In this embodiment, the second base portion **306** comprises three base liquid openings **426**. When the disc portion **310** is placed on the second base portion **306**, the liquid openings **401** are sealed from the air vent channels **336** and provide passage for the liquid to the nipple **230**.

[0055] The base portion **306** optionally includes an indented region **720** which allows the user to frictionally attach an anti-bubble tube **800** to the second base portion **306**. The anti-bubble tube **800** fits securely over the indented region **720** and assists in maintaining the diving bell function since the anti-bubble tube seals the region surrounding the duck-bill valve **701**. The four indents of the indented region **720** provide for the secure seal. Of course, fewer or additional indents may be used and still maintain a tight seal. However, four indents have shown

to be effective in providing a secure seal, yet still provide for the anti-bubble tube **800** to be removable from the indented region **720**.

[0056] In some embodiments, the anti-bubble tube **800** may include a heat sensor portion produced from micro-encapsulated temperature sensitive plastics. These plastics use color change to indicate specific temperature changes of liquid inside the container.

[0057] It will be appreciated that the second base portion **306** may also be used without the anti-bubble tube **800** and still prevent leakage from inside the bottle through the air vent channels.

[0058] In general, the vent system of the first embodiment or the second embodiment may also be used with a sippy cup and held in place by a sippy cup collar **226** that threadably connects to the sippy cup, as shown, for example, in **Figure 12**. The vent system **217** is substantially the same as for a baby bottle embodiment; however, one of ordinary skill in the art will readily be able to scale up the vent system to accommodate a larger sippy cup. The vent system **217** includes a disc portion **311** and a base portion **307** which cooperate, as described above, to provide liquid openings **402** for liquid flow from the container to the spout **232** of the sippy cup, and air vent channels **337** leading from air vent openings **332** to an integral valve **702**. The venting of the sippy cup works in an identical fashion as to the baby bottle, i.e., as the child sucks and a minimal vacuum is created inside the container, air passes between the threaded regions of the sippy cup container and the sippy cup collar into air vent openings **332** and through valve **702** into the container.

[0059] The vent system may be made from a variety of plastic/rubber materials, such as silicone and thermoplastic rubber. An especially preferred material for the base portion of the vent system is silicone, since it is easy to clean and safe for use.

[0060] It is an aspect of the present invention that leak resistant drinking containers are provided that may be filled with hot water, and may be completely filled with liquid. In addition, these drinking containers may be used with thick, as well as thin, formulas. Furthermore, the apparatus of the present invention remains leak-free when the bottle is squeezed, if the nipple attached to the bottle is squeezed, when the bottle is shaken to mix a formula, if the liquid is heated to above 45°C, or if the bottle is subjected to changes in atmospheric pressure. Even in these situations, the liquid is prevented by the one-way valve from flowing out through the air inlet passages.

[0061] As evident from the foregoing description, the present invention is not limited by the particular details of the examples illustrated herein, and it is therefore contemplated that other modifications and applications, or equivalents thereof, will occur to those skilled in the art. It is accordingly attended that all claims shall cover all such modifications and applications.

Claims

1. A vent system for drinking containers having a dispensing device (230) and a collar (225) coupling the dispensing device (230) to the container, the vent system comprising:

a substantially rigid disc portion (310) having a substantially planar lower surface (371) and a plurality of disc liquid openings (430) comprising descending members (431);

a base portion (305, 306) formed of flexible material including a plurality of base vent channels (415) recessed in said base portion and extending between the periphery of said base portion (305, 306) and a single, integral uni-directional valve (700, 701) that, in an open position, allows air to enter the drinking container and, in a closed position, prevents liquid flowing out of the container into said base vent channels (415), and further including a plurality of base liquid openings (425) complementary to said descending members (431) sealingly seated therein and sealed against said descending members (431); and

wherein said rigid, planar lower surface of said disc portion (310) covers said base vent channels (415) and forms and seals a top portion of the air vent channels (335), leading from air vent openings (330, 331) in the exterior of said vent system and merging into said valve (700, 701), allowing air to enter the container through said air vent channels (335) and said valve (700, 701).

2. The vent system according to claim 1, and further comprising an anti-bubble tube (800) extending to nearly a bottom of portion of the container, said anti-bubble tube (800) being releasably coupleable to said base portion (305, 306) and circumscribing said valve (700, 701), wherein the anti-bubble tube (800) traps a volume of air surrounding the valve (700, 701) when the valve is in a closed position, so as to create a "diving bell" effect within the anti-bubble tube (800).
3. The vent system according to claim 2, wherein said anti-bubble tube (800) comprises a heat sensor of a thermally reactive material to indicate a temperature of a liquid in the container.
4. The vent system according to claim 2 or claim 3, wherein said anti-bubble tube (800) has a lower section and an upper section, wherein the upper section generally surrounds the valve (700, 701), and wherein the lower section has a larger volume than the upper section.

5. A drinking container having a dispensing device (230) and a collar (225) coupling the dispensing device (230) to the container, the drinking container comprising:

a liquid container (200); and
a vent system (215) coupled to said liquid container (200), said vent system (215) comprising:

a substantially rigid disc portion (310) having a substantially planar lower surface and a plurality of disc liquid openings (430) comprising descending members (431);

a base portion (305, 306) formed of flexible material including a plurality of base vent channels (415) recessed therein and extending between the periphery of said base portion (305, 306) and a single, integral uni-directional valve (700, 701) that, in an open position, allows air to enter the liquid container (200) and, in a closed position, prevents liquid flowing out of the container into the base vent channels (415), and further including a plurality of base liquid openings (425) complementary to said descending members (431) and sealingly seated inside and sealed against said descending members, thereby forming liquid openings (400) which allow liquid to exit the container and prevent liquid from entering into said base vent channels (415); and

wherein said rigid lower surface of said disc portion (310) covers said base vent channels (415) and forms and seals a top portion of the air vent channels (335) between said planar lower surface (371) of the disc portion and said base vent channels (415), leading from air vent openings (330, 331) in the exterior of said vent system and merging into said valve (700, 701), allowing air to enter the container through said air vent channels (335) and said valve (700, 701).

6. The drinking container according to claim 5, further including a nipple and a collar, wherein the collar (225) is threadably connected to the container, and connecting said collar (225) to said container seals said nipple against said vent system, and wherein air passes in between a threaded region (500) of a neck (205) of the bottle and a threaded region (501) of said collar (225) and air enters said air vent channel openings (330).
7. The drinking container according to claim 5, further including a spout and a collar, wherein the collar (225) is threadably connected to said container, and connecting said collar (225) to said container seals said spout against said vent system, and wherein air

passes in between a threaded region (500) of a neck (205) of the bottle and a threaded region (501) of said collar (225) and air enters said air vent channel openings (330).

8. The drinking container according to any one of claims 5 to 7, and further comprising an anti-bubble tube (800) extending to nearly a bottom portion of said container, said anti-bubble tube (800) being releasably coupleable to said base portion (305, 306) and circumscribing said valve (700, 701), wherein said anti-bubble tube (800) traps a volume of air surrounding said valve (700, 701) when said valve (700, 701) is in a closed position, so as to create a "diving bell" effect within said anti-bubble tube (800).

9. A method for manufacturing a vent system for a drinking container having a dispensing device (230) and a collar (225) coupling the dispensing device (230) to the container, the method comprising:

providing a substantially rigid disc portion (310) having a substantially planar lower surface (371) and a plurality of disc liquid openings (430) comprising descending members (431);

providing a base portion (305, 306) formed of flexible material including a plurality of base vent channels (415) recessed in said base portion and extending between the periphery of said base portion (305, 306) and a single, integral uni-directional valve (700, 701) that, in an open position, allows air to enter the drinking container and, in a closed position, prevents liquid flowing out of the container into the base vent channels (415), and further including a plurality of base liquid openings (425) complementary to said descending members (431); and

coupling said disc portion (310) to said base portion (305, 306) to form air vent channels (335) between said planar lower surface (371) of the disc portion and said base vent channels (415), said rigid lower surface of said disc portion covering said base vent channels (415) and forming and sealing a top portion of the air vent channels, said air vent channels leading from air vent openings (330, 331) in the exterior of said vent system and merging into said valve (700, 701), allowing air to enter said container through said air vent channels (335) and said valve (700, 701),

and so that the disc liquid openings (430) sealingly seat inside and seal against the base liquid openings (425), thereby forming liquid openings which allow liquid to exit the container and prevent liquid from entering into said air vent channels (335).

10. The method according to Claim 9, and further com-

prising releasably coupling an anti-bubble tube (800) to said base portion (305, 306) and circumscribing said valve (700, 701), said anti-bubble tube (800) extending to nearly a bottom portion of said container, wherein said anti-bubble tube (800) traps a volume of air surrounding said valve (700, 701) when said valve is in a closed position, so as to create a "diving bell" effect within said anti-bubble tube (800).

Patentansprüche

1. Ein Belüftungssystem für Trinkgefäße, die eine Abgabevorrichtung (230) und einen Bund (225) haben, der die Abgabevorrichtung (230) mit dem Gefäß verbindet, wobei das Belüftungssystem Folgendes umfasst:

einen im Wesentlichen starren Scheibenabschnitt (310) mit einer im Wesentlichen planaren unteren Oberfläche (371) und einer Vielzahl von Scheiben-Flüssigkeitsöffnungen (430), die Senkglieder (431) umfassen;

einen Basisabschnitt (305, 306), bestehend aus biegsamem Material, der eine Vielzahl von Basis-Belüftungskanälen (415) einschließt, die vertieft in den Basisabschnitt eingebracht sind und sich zwischen der Peripherie des Basisabschnitts (305, 306) und einem einzigen, integralen Einwegventil (700, 701) erstrecken, das es in einer offenen Position ermöglicht, dass Luft in das Trinkgefäß eindringt, und in einer geschlossenen Position Flüssigkeit daran hindert, aus dem Behälter in die Basis-Belüftungskanäle (415) zu strömen; und der weiter eine Vielzahl von Basis-Flüssigkeitsöffnungen (425) einschließt, die komplementär zu den Senkgliedern (431), abdichtend darin eingesetzt und gegenüber den Senkgliedern (431) abgedichtet sind; und

wobei die starre, planare untere Oberfläche des Scheibenabschnitts (310) die Basis-Belüftungskanäle (415) abdeckt und einen oberen Abschnitt der Belüftungskanäle (335) bildet und abdichtet, der von Belüftungsöffnungen (330, 331) in der Außenseite des Belüftungssystems kommt und in das Ventil (700, 701) übergeht, wodurch es ermöglicht wird, dass Luft durch die Belüftungskanäle (335) und das Ventil (700, 701) in den Behälter eindringt.

2. Das Belüftungssystem gemäß Anspruch 1, das weiter ein Anti-Blasen-Rohr (800) umfasst, welches sich nahezu bis zu einem Boden eines Abschnitts des Behälters erstreckt, wobei das Anti-Blasen-Rohr (800) lösbar mit dem Basisabschnitt (305, 306) gekoppelt werden kann und das Ventil (700, 701) umschreibt, wobei das Anti-Blasen-Rohr (800) ein Vo-

- lumen von Luft einschließt, das das Ventil (700, 701) umgibt, wenn sich das Ventil in einer geschlossenen Position befindet, um so einen "Tauchglocken-"Effekt innerhalb des Anti-Blasen-Rohrs (800) zu erzeugen.
- 5
3. Das Belüftungssystem gemäß Anspruch 2, wobei das Anti-Blasen-Rohr (800) einen Wärmesensor aus einem thermisch reaktiven Material umfasst, um eine Temperatur einer Flüssigkeit im Behälter anzuzeigen.
- 10
4. Das Belüftungssystem gemäß Anspruch 2 oder Anspruch 3, wobei das Anti-Blasen-Rohr (800) einen unteren Abschnitt und einen oberen Abschnitt hat, wobei der obere Abschnitt das Ventil (700, 701) all-
gemein umgibt und wobei der untere Abschnitt ein größeres Volumen hat als der obere Abschnitt.
- 15
5. Ein Trinkgefäß mit einer Abgabevorrichtung (230) und einem Bund (225), der die Abgabevorrichtung (230) mit dem Gefäß koppelt, wobei das Trinkgefäß Folgendes umfasst:
- 20
- einen Flüssigkeitsbehälter (200); und
ein Belüftungssystem (215), das mit dem Flüssigkeitsbehälter (200) gekoppelt ist, wobei das Belüftungssystem (215) Folgendes umfasst:
- 25
- einen im Wesentlichen starren Scheibenabschnitt (310), der eine im Wesentlichen planare untere Oberfläche und eine Vielzahl von Scheiben-Flüssigkeitsöffnungen (430) hat, die Senkglieder (431) umfassen; einen Basisabschnitt (305, 306) aus biegsamem Material, der eine Vielzahl vertieft darin eingebrachter Basis-Belüftungskanäle (415) einschließt, die sich zwischen der Peripherie des Basisabschnitts (305, 306) und einem einzigen, integralen Einwegventil (700, 701) erstrecken, das es in einer offenen Position ermöglicht, dass Luft in den Flüssigkeitsbehälter (200) eindringt, und in einer geschlossenen Position Flüssigkeit daran hindert, aus dem Behälter in die Basis-Belüftungskanäle (415) zu strömen; und das weiter eine Vielzahl von Basis-Flüssigkeitsöffnungen (425) einschließt, die komplementär zu den Senkgliedern (431) und abdichtend in die Senkglieder eingesetzt und gegenüber ihnen abgedichtet sind, wodurch Flüssigkeitsöffnungen (400) gebildet werden, die es ermöglichen, dass Flüssigkeit aus dem Behälter austritt, und Flüssigkeit daran hindern, in die Basis-Belüftungskanäle (415) einzudringen; und wobei die starre untere Oberfläche des Scheibenabschnitts (310) die Basis-Belüf-
- 30
- 35
- 40
- 45
- 50
- 55
- tungskanäle (415) abdeckt und einen oberen Abschnitt der Belüftungskanäle (335) zwischen der planaren unteren Oberfläche (371) des Scheibenabschnitts und den Basis-Belüftungskanälen (415) bildet und abdichtet, der von Belüftungsöffnungen (330, 331) in der Außenseite des Belüftungssystems führt und in das Ventil (700, 701) übergeht, wodurch es ermöglicht wird, dass Luft durch die Belüftungskanäle (335) und das Ventil (700, 701) in den Behälter eindringt.
6. Das Trinkgefäß gemäß Anspruch 5, das weiter einen Nippel und einen Bund einschließt, wobei der Bund (225) verschraubbar mit dem Behälter verbunden ist und das Verbinden des Bundes (225) mit dem Behälter den Nippel gegenüber dem Belüftungssystem abdichtet und wobei Luft zwischen einen Gewindeabschnitt (500) eines Halses (205) der Flasche und einen Gewindeabschnitt (501) des Bundes (225) eindringt und Luft in die Belüftungsöffnungen (330) eindringt.
7. Das Trinkgefäß gemäß Anspruch 5, das weiter einen Ausguss und einen Bund einschließt, wobei der Bund (225), verschraubbar mit dem Gefäß verbunden ist und das Verbinden des Bundes (225) mit dem Gefäß den Ausguss gegenüber dem Belüftungssystem abdichtet und wobei Luft zwischen einen Gewindeabschnitt (500) eines Halses (205) der Flasche und einen Gewindeabschnitt (501) des Bundes (225) eindringt und Luft in die Belüftungsöffnungen (330) eindringt.
8. Das Trinkgefäß gemäß einem beliebigen der Ansprüche 5 bis 7, das weiter ein Anti-Blasen-Rohr (800) umfasst, das sich nahezu zu einem Bodenabschnitt des Behälters erstreckt, wobei das Anti-Blasen-Rohr (800) lösbar mit dem Basisabschnitt (305, 306) gekoppelt werden kann und das Ventil (700, 701) umschreibt, wobei das Anti-Blasen-Rohr (800) ein Volumen von Luft einschließt, das das Ventil (700, 701) umgibt, wenn sich das Ventil (700, 701) in einer geschlossenen Position befindet, um so einen "Tauchglocken-"Effekt innerhalb des Anti-Blasen-Rohrs (800) zu erzeugen.
9. Ein Verfahren zur Herstellung eines Belüftungssystems für ein Trinkgefäß, das eine Abgabevorrichtung (230) und einen Bund (225) hat, der die Abgabevorrichtung (230) mit dem Behälter koppelt, wobei das Verfahren Folgendes umfasst:
- Bereitstellen eines im Wesentlichen starren Scheibenabschnitts (310), der eine im Wesentlichen planare untere Oberfläche (371) und eine Vielzahl von Scheiben-Flüssigkeitsöffnungen (430) hat, die Senkglieder (431) umfassen;

Bereitstellen eines Basisabschnitts (305, 306), bestehend aus biegsamem Material, der eine Vielzahl von Basis-Belüftungskanälen (415) einschließt, die vertieft in den Basisabschnitt eingebracht sind und sich zwischen der Peripherie des Basisabschnitts (305, 306) und einem einzigen, integralen Einwegventil (700, 701) erstrecken, das es in einer offenen Position ermöglicht, dass Luft in das Trinkgefäß eindringt, und in einer geschlossenen Position Flüssigkeit daran hindert, aus dem Behälter in die Basis-Belüftungskanäle (415) zu strömen; und der weiter eine Vielzahl von Basis-Flüssigkeitsöffnungen (425) einschließt, die komplementär zu den Senkgliedern (431) sind; und Koppeln des Scheibenabschnitts (310) mit dem Basisabschnitt (305, 306), um Belüftungskanäle (335) zwischen der planaren unteren Oberfläche (371) des Scheibenabschnitts und den Basis-Belüftungskanälen (415) zu bilden, wobei die starre untere Oberfläche des Scheibenabschnitts die Basis-Belüftungskanäle (415) abdeckt und einen oberen Abschnitt der Belüftungskanäle bildet und abdichtet, wobei die Belüftungskanäle von Belüftungsöffnungen (330, 331) in der Außenseite des Belüftungssystems ausgehen und in das Ventil (700, 701) übergehen und es so ermöglichen, dass Luft durch die Belüftungskanäle (335) und das Ventil (700, 701) in den Behälter eindringt, und so, dass die Scheiben-Flüssigkeitsöffnungen (430) abdichtend in den Basis-Flüssigkeitsöffnungen (425) sitzen und gegenüber ihnen abdichten, dadurch Flüssigkeitsöffnungen bildend, die es ermöglichen, dass Flüssigkeit aus dem Behälter austritt, und Flüssigkeit daran hindern, in die Belüftungskanäle (335) einzudringen.

10. Das Verfahren gemäß Anspruch 9, das weiter das lösbare Koppeln eines Anti-Blasen-Rohrs (800) mit dem Basisabschnitt (305, 306) und das Umschreiben des Ventils (700, 701) umfasst, wobei das Anti-Blasen-Rohr (800) sich nahezu bis zu einem Bodenabschnitt des Behälters erstreckt, wobei das Anti-Blasen-Rohr (800) ein Volumen an Luft einschließt, das das Ventil (700, 701) umgibt, wenn das Ventil sich in einer geschlossenen Position befindet, um so einen "Tauchglocken"-Effekt innerhalb des Anti-Blasen-Rohrs (800) zu erzeugen.

Revendications

1. Système d'aération pour récipients pour liquide à boire ayant un dispositif de distribution (230) et une bague (225) accrochant le dispositif de distribution (230) au récipient, le système d'aération

comportant :

une partie formant disque sensiblement rigide (310) ayant une surface inférieure sensiblement plane (371) et, dans le disque, une pluralité d'ouvertures (430) pour liquide comprenant des éléments descendants (431) ;

une partie formant embase (305, 306) en matière flexible comprenant une pluralité de conduits d'aération (415) d'embase nichés dans ladite partie formant embase et s'étendant entre le pourtour de ladite partie formant embase (305, 306) et une unique valve unidirectionnelle incorporée (700, 701) qui, en position d'ouverture, laisse entrer de l'air dans le récipient pour liquide à boire et, en position de fermeture, empêche que du liquide sortant du récipient ne pénètre dans lesdits conduits d'aération (415) d'embase, et comprenant en outre une pluralité d'ouvertures (425) d'embase pour liquide, complémentaires desdits éléments descendants (431), logées d'une manière fixe dans ceux-ci et fixés d'une manière étanche contre lesdits éléments descendants (431) ; et

dans lequel ladite surface inférieure plane rigide de ladite partie formant disque (310) couvre lesdits conduits d'aération (415) d'embase et forme et fixe une partie supérieure des conduits d'aération (335), partant d'ouvertures d'aération (330, 331) présentes dans ledit système d'aération et se fondant dans ladite valve (700, 701), laissant entrer de l'air dans le récipient par lesdits conduits d'aération (335) et ladite valve (700, 701).

2. Système d'aération selon la revendication 1, et comportant en outre un tuyau anti-bulles (800) s'étendant presque jusqu'au fond d'une partie du récipient, ledit tuyau anti-bulles (800) pouvant être accroché d'une manière libérable à ladite partie formant embase (305, 306) et englobant ladite valve (700, 701), le tuyau anti-bulles (800) piégeant un volume d'air entourant la valve (700, 701) lorsque la valve est en position de fermeture, de manière à créer un effet de "cloche de plongée" à l'intérieur du tuyau anti-bulles (800).
3. Système d'aération selon la revendication 2, dans lequel ledit tuyau anti-bulles (800) comprend un détecteur de chaleur en matière thermo-réactive pour indiquer une température d'un liquide présent dans le récipient.
4. Système d'aération selon la revendication 2 ou la revendication 3, dans lequel ledit tuyau anti-bulles (800) a une section inférieure et une section supérieure, la section supérieure entourant globalement la valve (700, 701), et dans lequel la section infé-

rieure a un volume plus grand que celui de la section supérieure.

5. Récipient pour liquide à boire ayant un dispositif de distribution (230) et une bague (225) accrochant le dispositif de distribution (230) au récipient, le récipient pour liquide à boire comportant :

un récipient (200) pour liquide ; et
un système d'aération (215) accroché audit récipient (200) pour liquide, ledit système d'aération (215) comportant :

une partie formant disque sensiblement rigide (310) ayant une surface inférieure sensiblement plane et, dans le disque, une pluralité d'ouvertures (430) pour liquide comprenant des éléments descendants (431) ; une partie formant embase (305, 306) en matière flexible comprenant une pluralité de conduits d'aération (415) d'embase nichés dans celle-ci et s'étendant entre le pourtour de ladite partie formant embase (305, 306) et une unique valve unidirectionnelle incorporée (700, 701) qui, en position d'ouverture, laisse entrer de l'air dans le récipient (200) pour liquide et, en position de fermeture, empêche que du liquide sortant du récipient ne pénètre dans lesdits conduits d'aération (415) d'embase, et comprenant en outre une pluralité d'ouvertures (425) d'embase pour liquide, complémentaires desdits éléments descendants (431) et logées d'une manière fixe dans ceux-ci lesdits éléments descendants et en appui hermétique contre ceux-ci, en formant de la sorte des ouvertures (400) pour liquide qui laissent un liquide sortir du récipient et empêchent que du liquide ne pénètre dans lesdits conduits d'aération (415) d'embase ; et

dans lequel ladite surface inférieure rigide de ladite partie formant disque (310) couvre lesdits conduits d'aération (415) d'embase et forme et fixe une partie supérieure des conduits d'aération (335) entre ladite surface inférieure plane (371) de la partie formant disque et lesdits conduits d'aération (415) d'embase, partant d'ouvertures d'aération (330, 331) présentes à l'extérieur dudit système d'aération et se fondant dans ladite valve (700 701), laissant entrer de l'air dans le récipient par lesdits conduits d'aération (335) et ladite valve (700, 701).

6. Récipient pour liquide à boire selon la revendication 5, comportant en outre une tétine et une bague, la bague (225) étant vissée sur le récipient et la liaison de ladite bague (225) avec ledit récipient immobili-

sant ladite tétine contre ledit système d'aération, et de l'air passant entre une région filetée (500) d'un goulot (205) du biberon et une région filetée (501) de ladite bague (225) et de l'air entrant dans lesdites ouvertures (330) de conduits d'aération.

7. Récipient pour liquide à boire selon la revendication 5, comportant en outre un bec et une bague, la bague (225) étant vissée sur ledit récipient, et l'accrochage de ladite bague (225) sur le récipient immobilisant ledit bec contre ledit système d'aération, et de l'air passant entre une région filetée (500) d'un goulot (205) du biberon et une région filetée (501) de ladite bague (225) et de l'air pénétrant dans lesdites ouvertures (330) de canaux d'aération.

8. Récipient pour liquide à boire selon l'une quelconque des revendications 5 à 7, et comportant en outre un tuyau anti-bulles (800) s'étendant presque jusqu'au fond d'une partie du récipient, ledit tuyau anti-bulles (800) pouvant être accroché d'une manière libérable à ladite partie formant embase (305, 306) et englobant ladite valve (700, 701), le tuyau anti-bulles (800) piégeant un volume d'air entourant la valve (700, 701) lorsque la valve (700, 701) est en position de fermeture, de manière à créer un effet de "cloche de plongée" à l'intérieur du tuyau anti-bulles (800).

9. Procédé pour fabriquer un système d'aération pour un récipient pour liquide à boire ayant un dispositif de distribution (230) et une bague (225) accrochant le dispositif de distribution (230) au récipient, le procédé comportant :

la réalisation d'une partie formant disque sensiblement rigide (310) ayant une surface inférieure sensiblement plane (371) et, dans le disque, une pluralité d'ouvertures (430) pour liquide comprenant des éléments descendants (431) ; la réalisation d'une partie formant embase (305, 306) en matière flexible comprenant une pluralité de conduits d'aération (415) d'embase nichés dans ladite partie formant embase et s'étendant entre le pourtour de ladite partie formant embase (305, 306) et une unique valve unidirectionnelle incorporée (700, 701) qui, en position d'ouverture, laisse entrer de l'air dans le récipient pour liquide à boire et, en position de fermeture, empêche que du liquide sortant du récipient ne pénètre dans lesdits conduits d'aération (415) d'embase, et comprenant en outre une pluralité d'ouvertures (425) d'embase pour liquide, complémentaires desdits éléments descendants (431); et

l'accrochage de ladite partie formant disque (310) à ladite partie formant embase (305, 306) afin de former des conduits d'aération (335) entre ladite surface inférieure plane (371) de la par-

tie formant disque et lesdits conduits d'aération
 (415) d'embase, ladite surface inférieure rigide
 de ladite partie formant disque couvrant lesdits
 conduits d'aération (415) et formant et fixant une
 partie supérieure des conduits d'aération, les- 5
 dits conduits d'aération partant d'ouvertures
 d'aération (330, 331) présentes à l'extérieur du-
 dit système d'aération et se fondant dans ladite
 valve (700, 701), laissant entrer de l'air dans le- 10
 dit récipient par lesdits conduits d'aération (335)
 et ladite valve (700, 701),
 et de façon que les ouvertures (430) pour liquide
 du disque soient logées d'une manière fixe à
 l'intérieur des ouvertures (425) d'embase pour 15
 liquide et appuient hermétiquement contre, en
 formant de la sorte des ouvertures pour liquide
 qui laissent un liquide sortir du récipient et em-
 pêchent que du liquide ne pénètre dans lesdits
 conduits d'aération (335).

20

- 10.** Procédé selon la revendication 9, et comportant en
 outre l'accrochage, d'une manière libérable, d'un
 tuyau anti-bulles (800) à ladite partie formant emba-
 se (305, 306) et l'enveloppement de ladite valve 25
 (700, 701), ledit tuyau anti-bulles (800) s'étendant
 presque jusqu'au fond d'une partie dudit récipient,
 ledit tuyau anti-bulles (800) piégeant un volume d'air
 entourant ladite valve (700, 701) lorsque ladite valve
 est en position de fermeture, de manière à créer un 30
 effet de "cloche de plongée" à l'intérieur dudit tuyau
 anti-bulles (800).

35

40

45

50

55

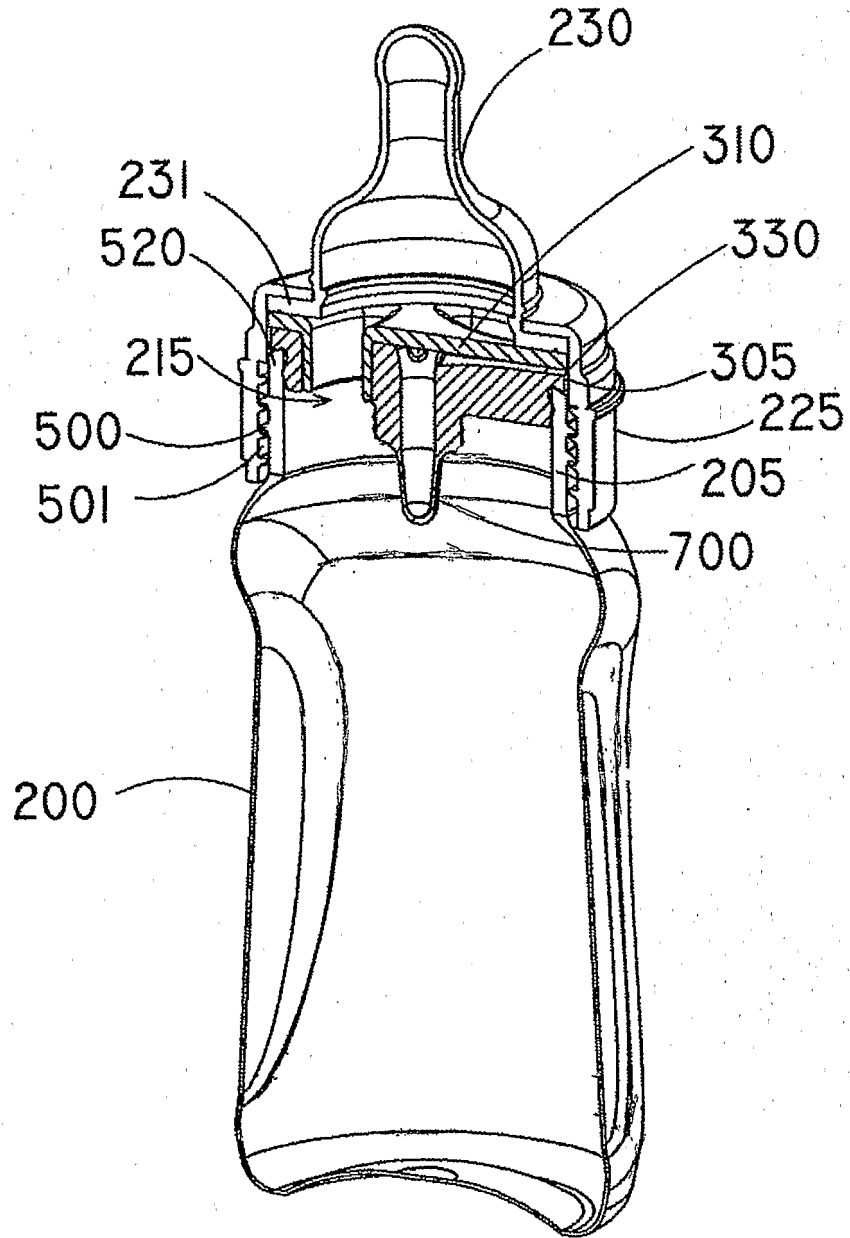

FIG. 1

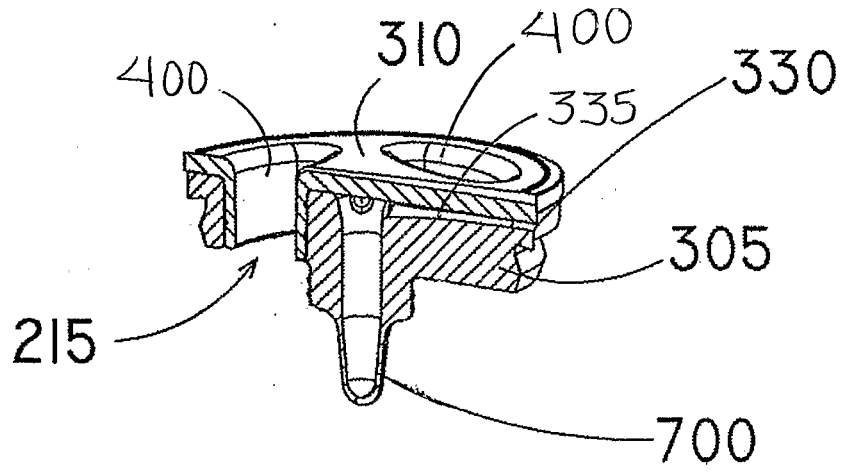

FIG. 2

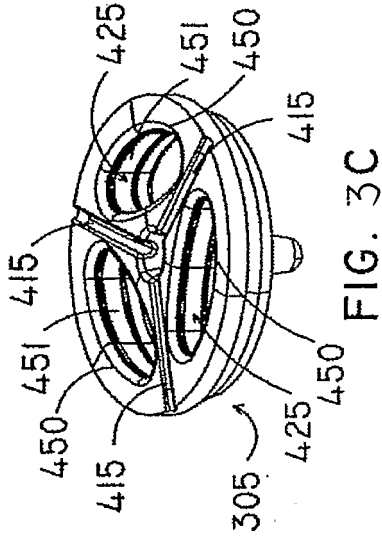

FIG. 3C

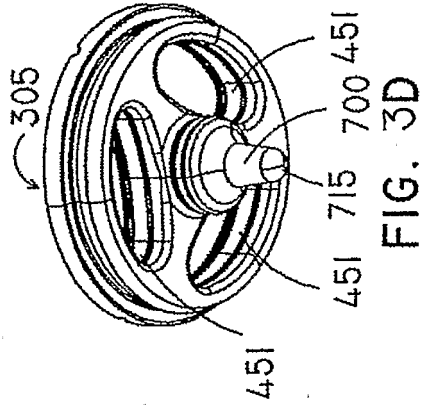

FIG. 3D

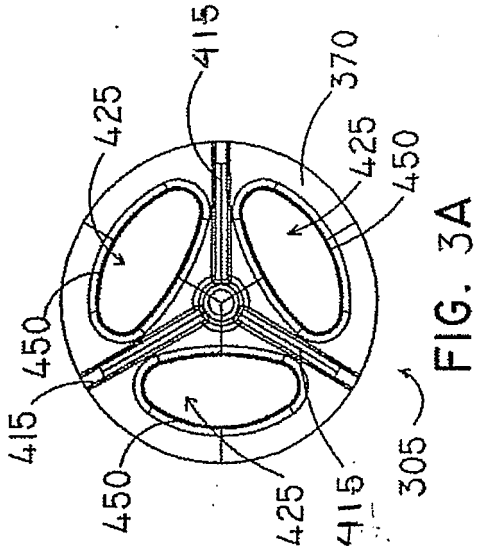

FIG. 3A

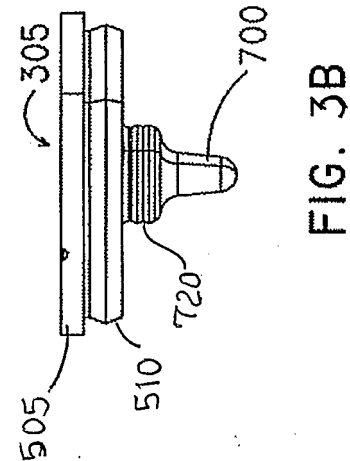

FIG. 3B

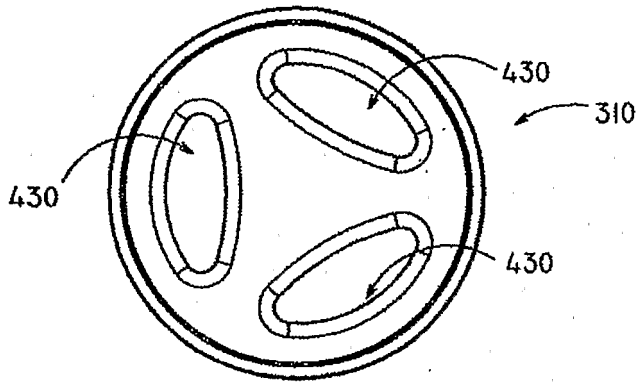

FIG. 4A

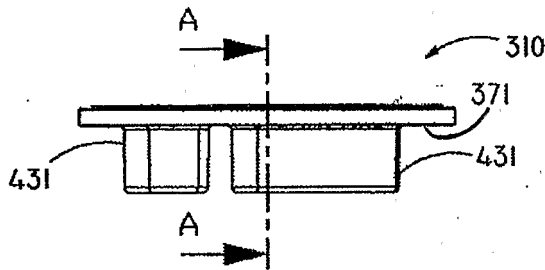

FIG. 4B

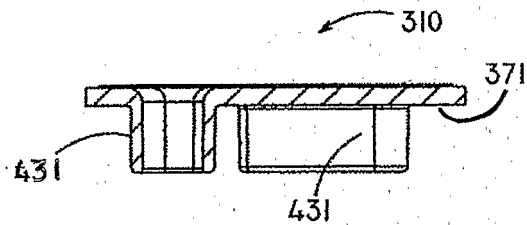

FIG. 4D

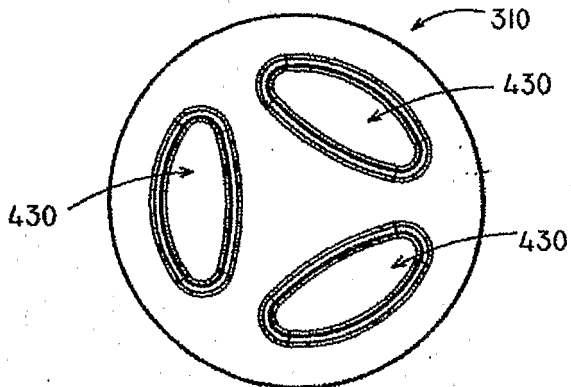

FIG. 4C

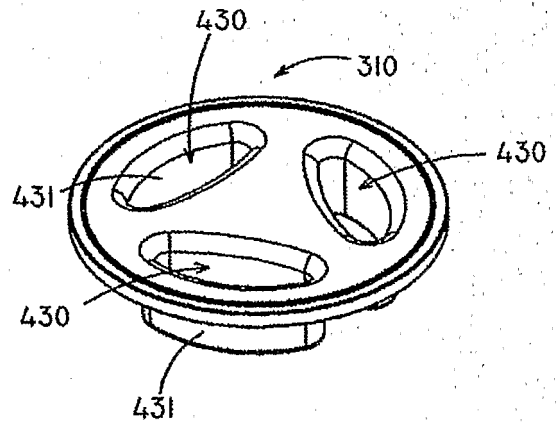

FIG. 4E

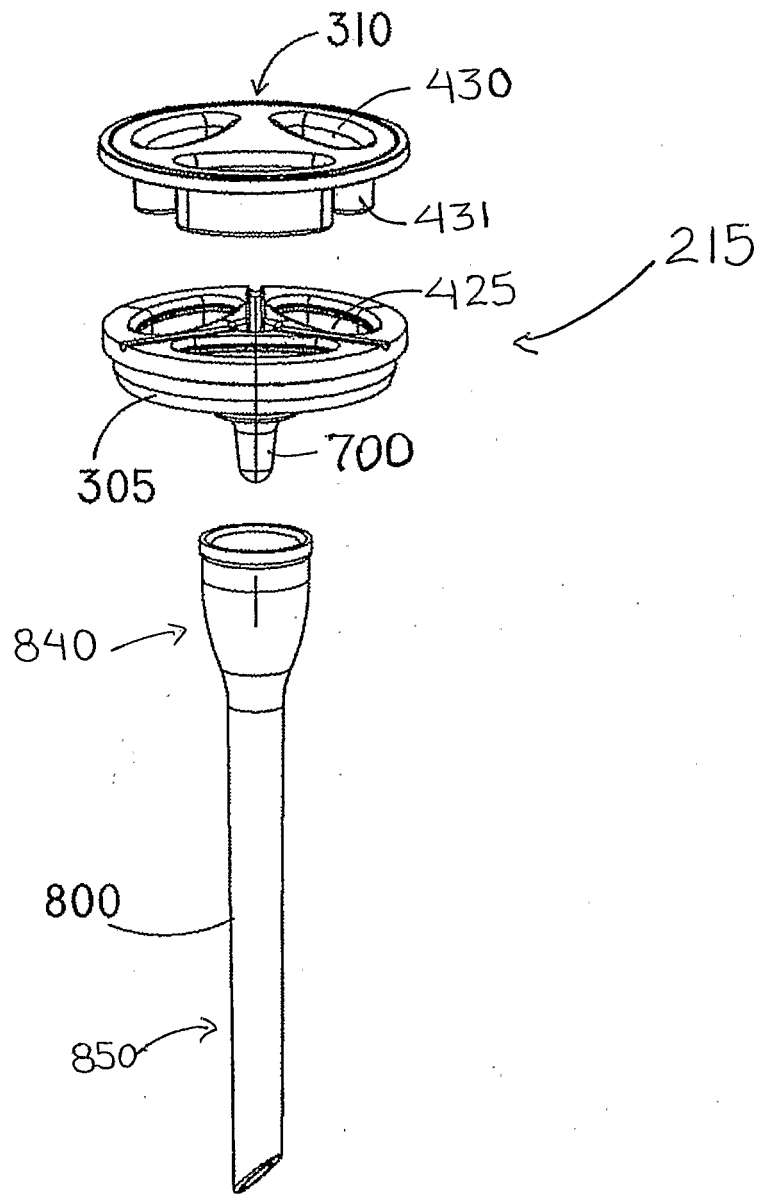
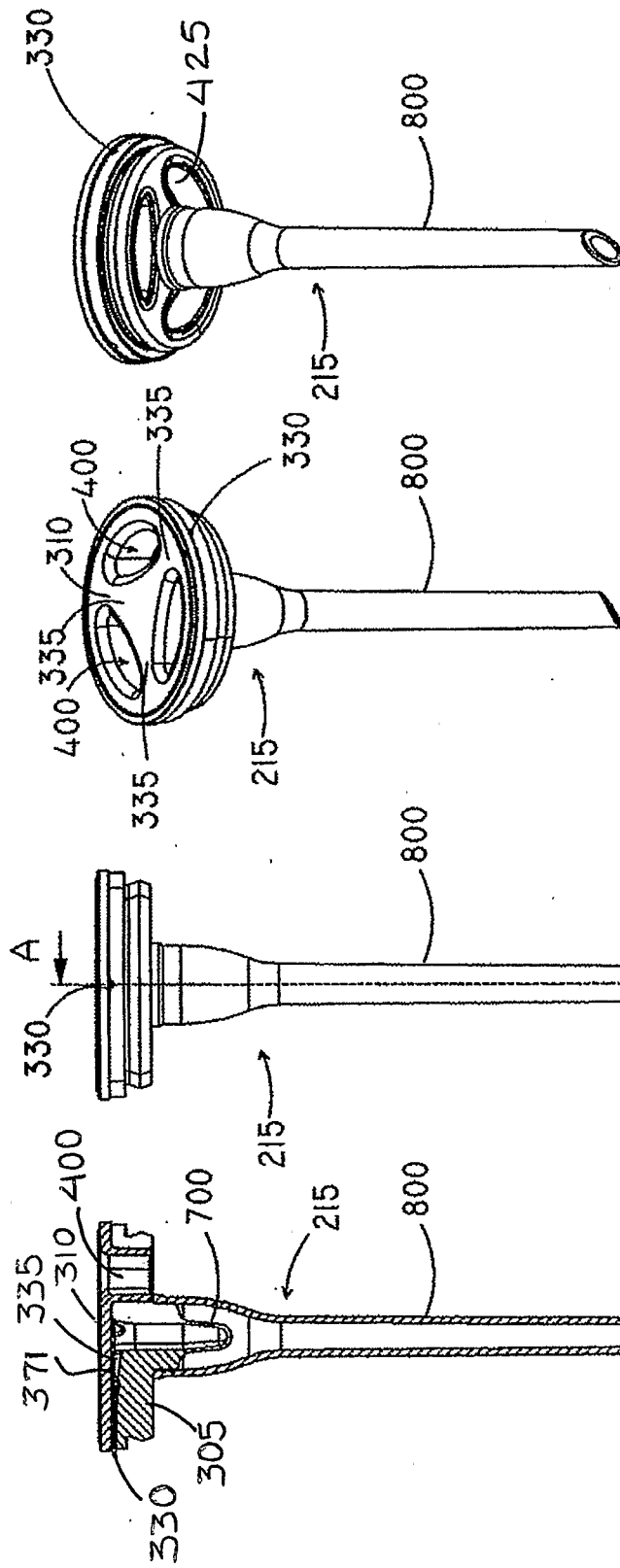

FIG. 5



A-A
FIG. 6A

FIG. 6B

FIG. 6C

FIG. 6D

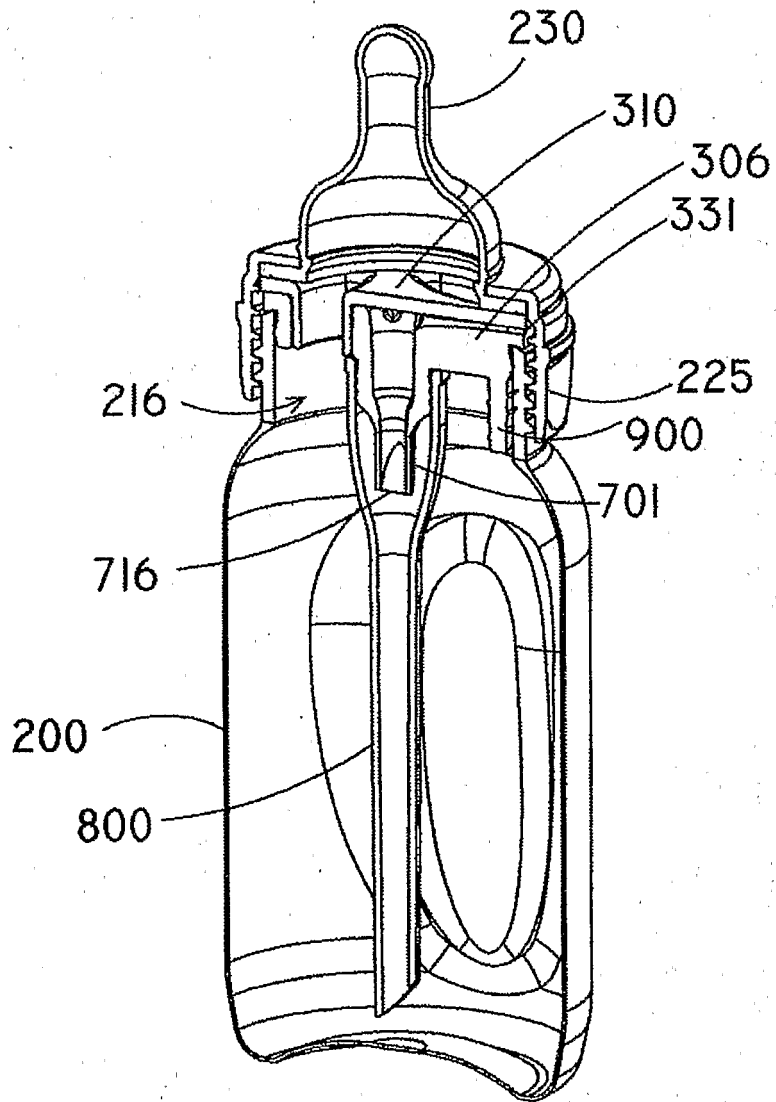

FIG. 7

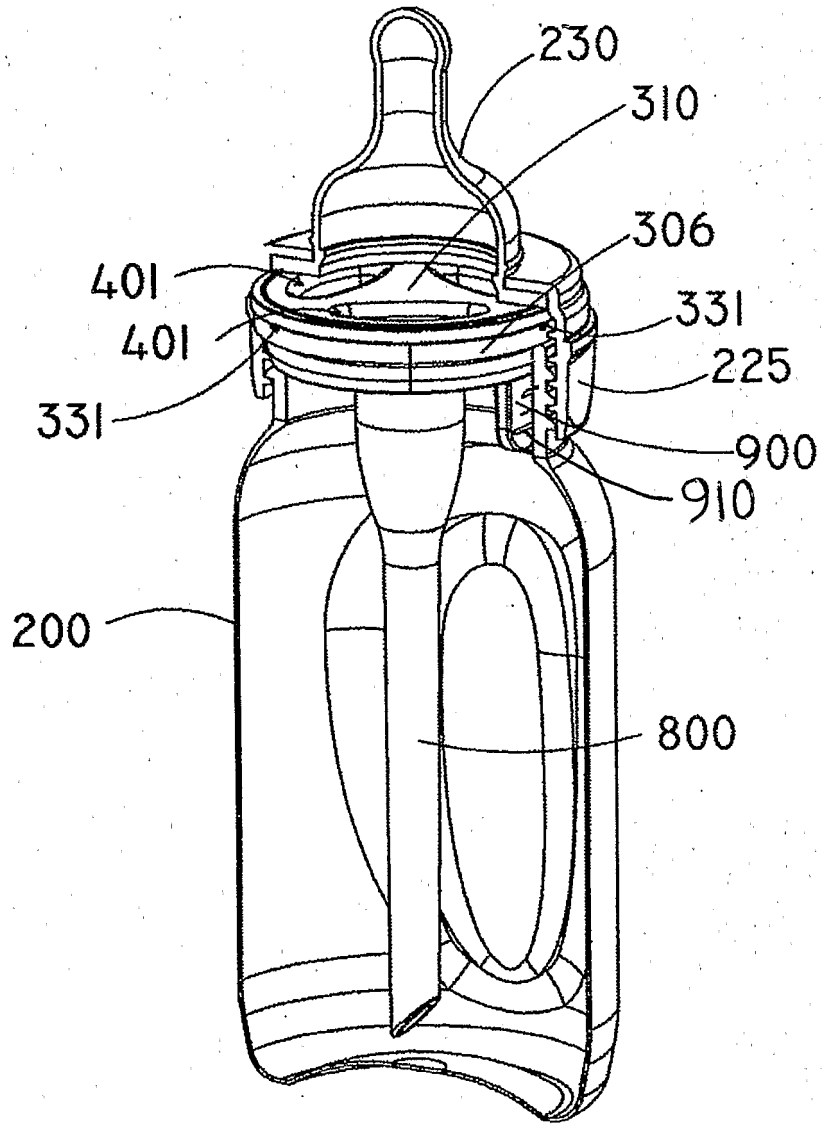
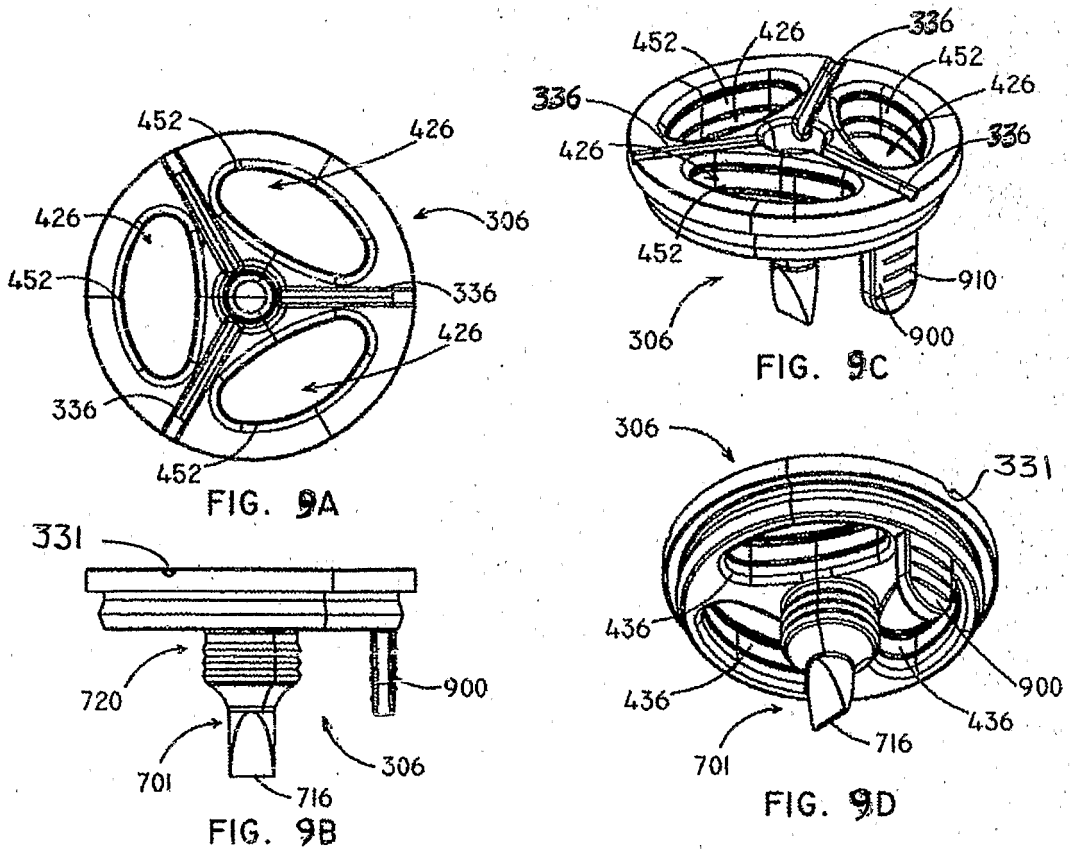

FIG. 8



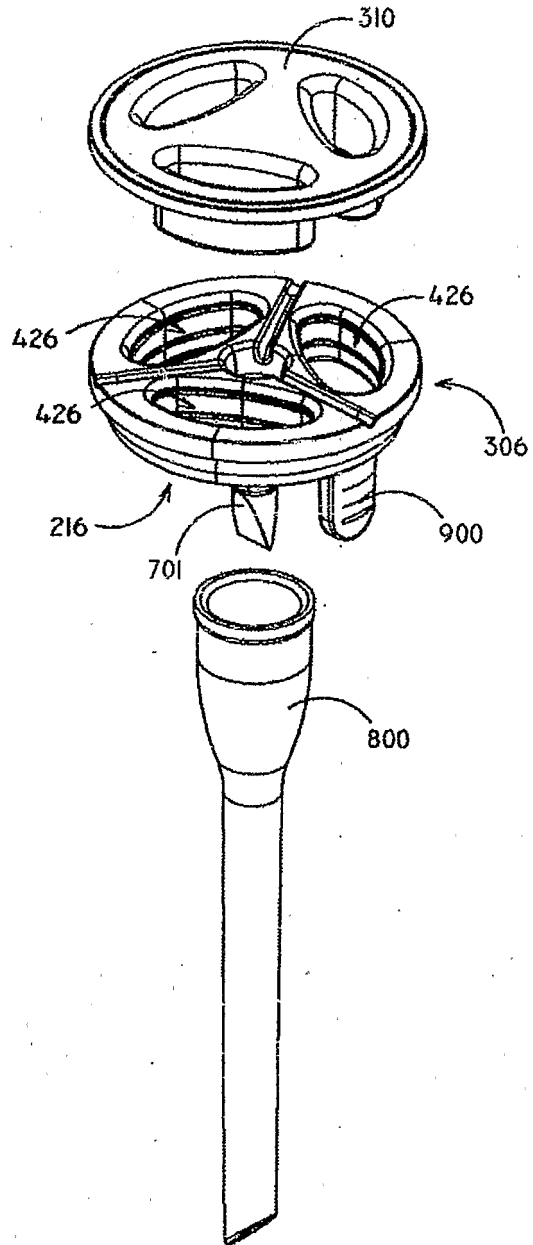

FIG. 10

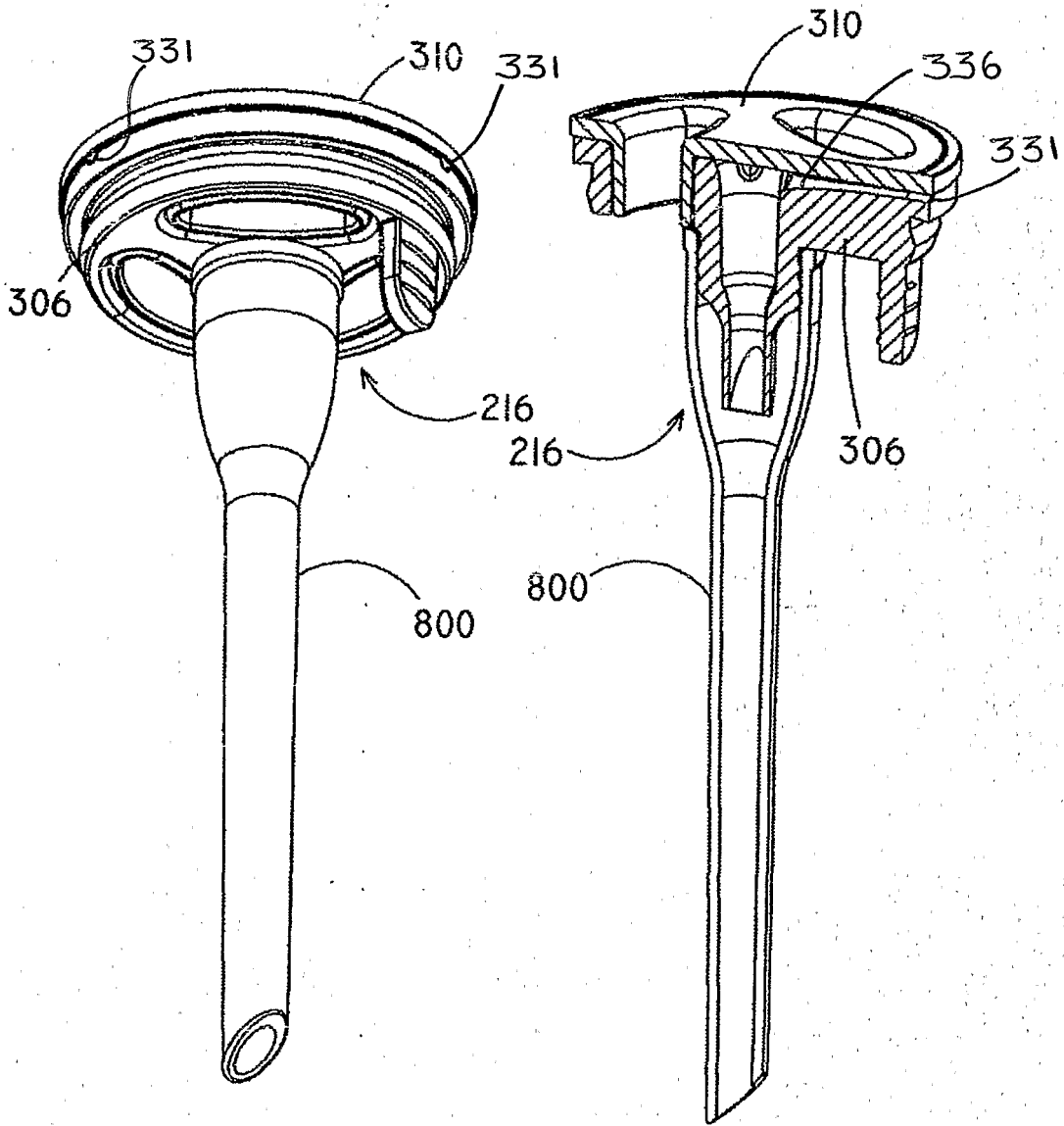
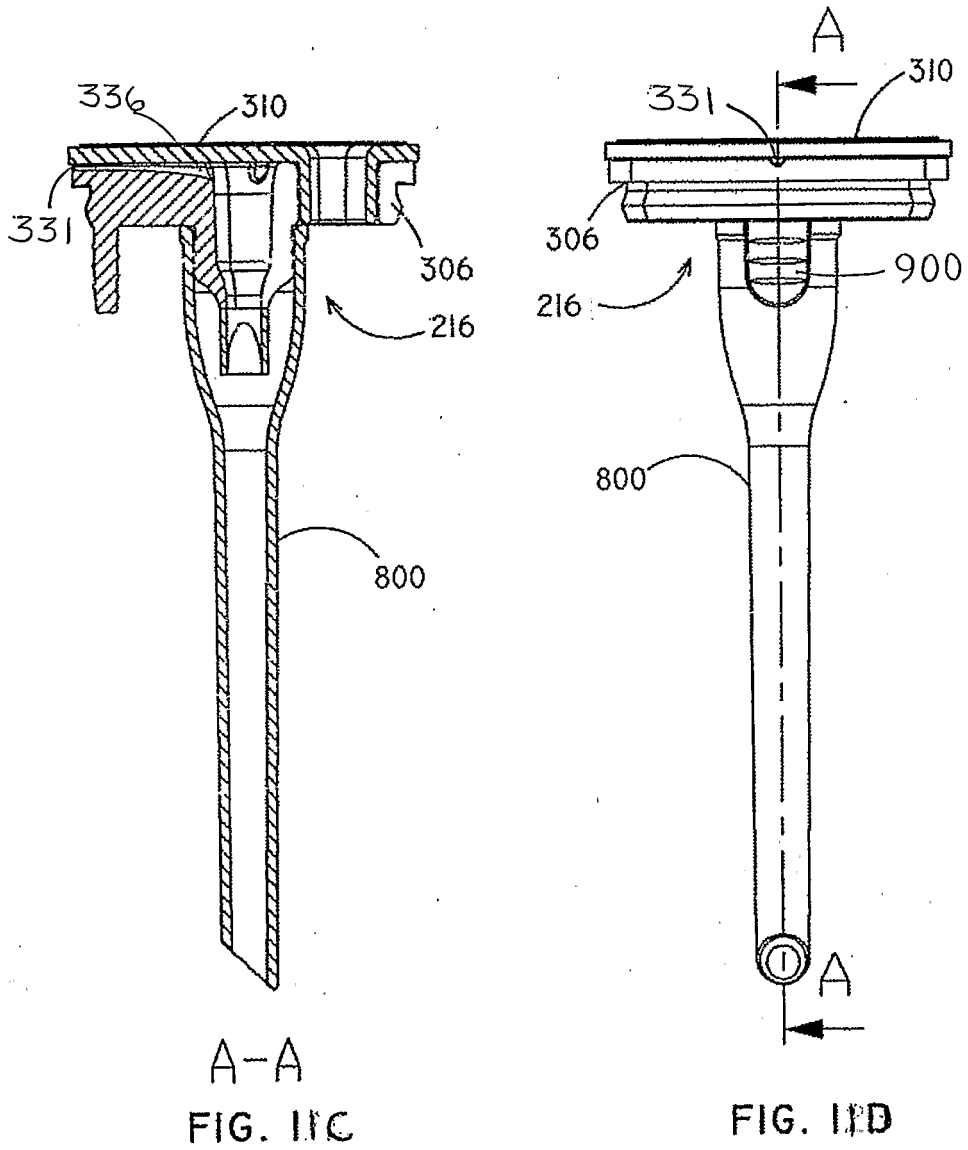

FIG. 11A

FIG. 11B



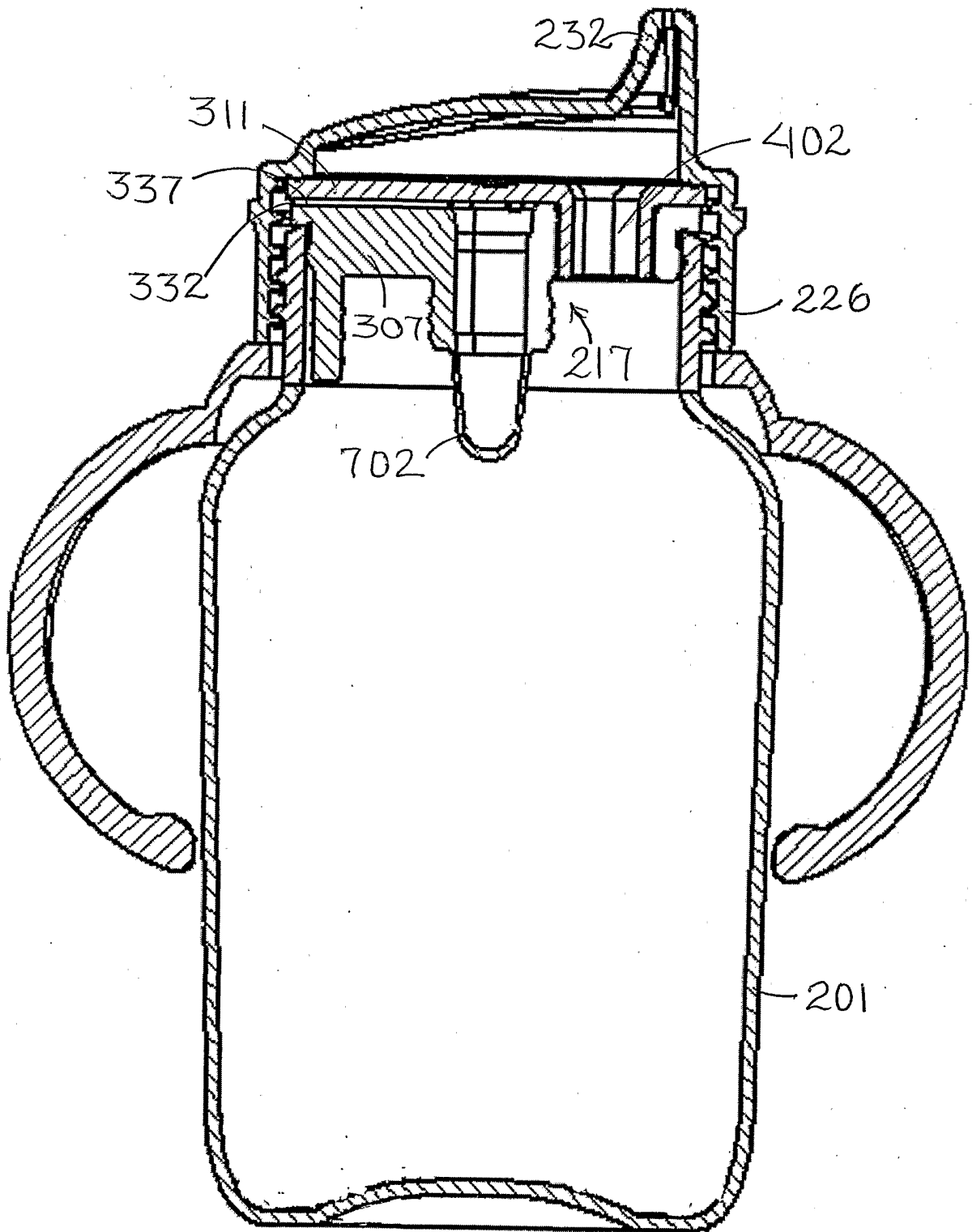

FIG. 12

REFERENCES CITED IN THE DESCRIPTION

This list of references cited by the applicant is for the reader's convenience only. It does not form part of the European patent document. Even though great care has been taken in compiling the references, errors or omissions cannot be excluded and the EPO disclaims all liability in this regard.

Patent documents cited in the description

- US 60617375 B [0001]
- US 5570796 A [0003] [0004] [0006] [0007]
- US 5779071 A [0003] [0004] [0006] [0007]
- WO 2004075810 A [0008]
- GB 2167735 A [0010]